

EPSON®
EXCEED YOUR VISION

EPL-N2550

User's Guide

Copyright and Trademarks

No part of this publication may be reproduced, stored in a retrieval system, or transmitted in any form or by any means, mechanical, photocopying, recording, or otherwise, without the prior written permission of Seiko Epson Corporation. No patent liability is assumed with respect to the use of the information contained herein. Neither is any liability assumed for damages resulting from the use of the information contained herein.

Neither Seiko Epson Corporation nor its affiliates shall be liable to the purchaser of this product or third parties for damages, losses, costs, or expenses incurred by purchaser or third parties as a result of: accident, misuse, or abuse of this product or unauthorized modifications, repairs, or alterations to this product, or (excluding the U.S.) failure to strictly comply with Seiko Epson Corporation's operating and maintenance instructions.

Seiko Epson Corporation and its affiliates shall not be liable against any damages or problems arising from the use of any options or any consumable products other than those designated as Original Epson Products or Epson Approved Products by Seiko Epson Corporation.

Features Zoran Corporation Integrated Print System (IPS) for print language emulation.



NEST Office Kit Copyright © 1996, Novell, Inc. All rights reserved.

A part of the ICC Profile contained within this product was created by Gretag Macbeth ProfileMaker. Gretag Macbeth is the registered trademark of Gretag Macbeth Holding AG Logo. ProfileMaker is the trademark of LOGO GmbH.

IBM and PS/2 are registered trademarks of International Business Machines Corporation. Microsoft® and Windows® are registered trademarks of Microsoft Corporation in the United States of America and other countries.

Apple® and Macintosh® are registered trademarks of Apple Computer, Inc.

EPSON and EPSON ESC/P are registered trademarks and EPSON ESC/P 2 is a trademark of Seiko Epson Corporation.

Coronet is a trademark of Ludlow Industries (UK) Ltd.

Marigold is a trademark of Arthur Baker and may be registered in some jurisdictions.

CG Times and CG Omega are trademarks of Agfa Monotype Corporation and may be registered in certain jurisdictions.

Arial, Times New Roman and Albertus are trademarks of The Monotype Corporation and may be registered in certain jurisdictions.

ITC Avant Garde Gothic, ITC Bookman, ITC Zapf Chancery and ITC Zapf Dingbats are trademarks of International Typeface Corporation and may be registered in some jurisdictions.

Antique Olive is a trademark of Fonderie Olive.

Helvetica, Palatino, Times, Univers, Clarendon, New Century Schoolbook, Miriam and David are trademarks of Heidelberger Druckmaschinen AG which may be registered in certain jurisdictions.

Wingdings is a trademark of Microsoft Corporation and may be registered in some jurisdictions.

HP, HP LaserJet and PCL are registered trademarks of the Hewlett-Packard Company.

Adobe, the Adobe logo and PostScript3 are trademarks of Adobe Systems Incorporated, which may be registered in certain jurisdictions.

General Notice: Other product names used herein are for identification purposes only and may be trademarks of their respective owners. Epson disclaims any and all rights in those marks.

Copyright © 2006 Seiko Epson Corporation. All rights reserved.

Contents

Copyright and Trademarks

Safety Instructions

Safety	13
Warnings, Cautions, and Notes	13
Safety precautions	13
Important Safety Instructions	17
Safety Information	21
Power On/Off Cautions	23

Chapter 1 Getting to Know Your Printer

Where to Find Information	24
Printer Parts	25
Front view	25
Rear view	26
Inside the printer	27
Control panel	28
Options and Consumable Products	29
Options	29
Consumable products	30

Chapter 2 Printer Features and Various Printing Options

Printer Features	31
High-quality printing	31
Toner save mode	31
Resolution Improvement Technology (RITech)	31
Wide variety of fonts	32
Adobe PostScript 3 Mode	32
PCL6 Emulation Mode	32

Various Printing Options	32
Double-sided printing	33
Fit to page printing	34
Pages per sheet printing	34
Watermark printing	35
Overlay printing	36
Web-Page Printing	36

Chapter 3 Paper Handling

Paper Sources	38
MP tray	38
Standard lower paper cassette	39
550-Sheet Universal Paper Cassette Unit	39
Selecting a paper source	39
Loading Paper	41
MP tray and standard lower paper cassette	43
550-Sheet Universal Paper Cassette Unit	49
Output tray	50
Printing on Special Media	50
Envelopes	51
Labels	54
Thick paper and extra thick paper	55
Transparencies	56
Loading a custom paper size	56

Chapter 4 Using the Printer Software with Windows

About the Printer Software	58
Accessing the printer driver	58
Making Changes to Printer Settings	59
Making the print quality settings	59
Duplex printing	65
Displaying information about consumables with the printer driver	67
Ordering Consumables	68
Resizing printouts	68

Modifying the print layout	71
Using a watermark	73
Using an overlay	76
Making Extended Settings	82
Making Optional Settings	85
Printing a status sheet.	85
Monitoring Your Printer Using EPSON Status Monitor	86
Installing EPSON Status Monitor	86
Accessing EPSON Status Monitor	89
Information on EPSON Status Monitor	91
Simple Status	92
Detailed Status	93
Consumables Information	94
Job Information	96
Notice Settings	99
Order Online	100
Tray Icon Settings	102
Setting Up the USB Connection	103
Canceling Printing	104
Uninstalling the Printer Software	105
Uninstalling the printer driver	105
Uninstall the USB device driver	108
Sharing the Printer on a Network	110
Sharing the printer	110
Setting up your printer as a shared printer	111
Using an additional driver.	112
Setting up clients	118
Installing the printer driver from the CD-ROM.	125

Chapter 5 Using the PostScript Printer Driver

About the PostScript 3 Mode	127
System requirements.	127
Using the PostScript Printer Driver with Windows	129
Installing the PostScript printer driver for the parallel interface	129
Installing the PostScript printer driver for the USB interface.	131

Installing the PostScript printer driver for the network interface	133
Accessing the PostScript printer driver.	134
Making changes to PostScript printer settings.	135
Using AppleTalk under Windows 2000	136
Using the PostScript Printer Driver with Macintosh	137
Installing the PostScript printer driver	137
Selecting the printer	138
Accessing the PostScript printer driver.	143
Making changes to PostScript printer settings.	143

Chapter 6 Using the PCL6 Printer Driver

About the PCL6 Mode	146
Hardware requirements	146
System requirements	146
Using the PCL6 Printer Driver	147

Chapter 7 Using the Control Panel

Using the Control Panel Menus	149
When to make control panel settings	149
How to access the control panel menus	149
Control Panel Menus.	151
Information Menu	151
Tray Menu	153
Emulation Menu	155
Printing Menu	155
Setup Menu	158
Reset Menu	163
Parallel Menu	164
USB Menu	166
Network Menu	168
AUX Menu.	168
LJ4 Menu	168
PS3 Menu	171
ESCP2 Menu	172

FX Menu	175
I239X Menu	178
Status and Error Messages	181
Printing a Status Sheet	192
Canceling Printing	193
Using the Cancel Job button	193
Using the Reset menu	193

Chapter 8 Installing Options

550-Sheet Universal Paper Cassette Unit	194
Handling precautions	194
Installing the 550-Sheet Universal Paper Cassette Unit	195
Removing the 550-Sheet Universal Paper Cassette Unit	198
Duplex Unit	198
Installing the Duplex Unit	198
Removing the Duplex Unit	201
Memory Module	202
Installing a memory module	202
Removing a memory module	207
Interface Card	208
Installing an interface card	208
Removing an interface card	211

Chapter 9 Replacing Consumable Products

Replacement Messages	212
Imaging Cartridge	213
Handling precautions	213
Replacing an imaging cartridge	214
Fuser Unit	217
Handling precautions	217
Replacing the fuser unit	218

Chapter 10 *Cleaning and Transporting the Printer*

Cleaning the Printer	223
Cleaning the pickup roller.....	223
Transporting the Printer.....	227
For long distances.....	227
For short distances	227
Finding a place for the printer	229

Chapter 11 *Troubleshooting*

Clearing Jammed Paper	231
Precautions for clearing jammed paper	231
Jam A (Cover A).....	232
Jam A B (Cover A or B)	235
Jam DM (Cover DM)	240
Jam MP A, Jam C1 A, Jam C2 A, Jam C3 A (All paper cassettes and Cover A).....	242
Printing a Status Sheet	245
Operational Problems	245
The Ready light does not turn on.	245
The printer does not print (Ready light off)	245
The Ready light is on but nothing prints	246
The optional product is not available	246
The Properties dialog box does not appear or it takes too much time to open it (For Windows Only)	247
The amount of a toner remaining is not updated (For Windows users only)	247
Printout Problems	248
The font cannot be printed	248
Printout is garbled	248
The printout position is not correct.....	249
Graphics do not print correctly	249
Print Quality Problems.....	249
The background is dark or dirty	249
White dots appear in the printout	250
Print quality or tone is uneven	250
Half-tone images print unevenly	251

Toner smudges	251
Areas are missing in the printed image	252
Completely blank pages are output	252
The printed image is light or faint	253
The non-printed side of the page is dirty	254
Memory Problems	254
Print quality decreased.	254
Insufficient memory for current task	254
Insufficient memory to print all copies	254
Paper Handling Problems	255
Paper does not feed properly	255
Problems Using Options	256
The message Invalid AUX /IF Card appears on the LCD panel	256
Paper does not feed from the optional paper cassette	256
Feed jam when using the optional paper cassette	257
An installed option cannot be used	257
Correcting USB Problems	257
USB connections	257
Windows operating system	258
Printer software installation	258
Status and Error Messages	265
Canceling Printing	265
Printing in the PostScript 3 Mode Problems	265
The printer does not print correctly in the PostScript mode	266
The printer does not print	266
The printer driver or printer that you need to use does not appear in the Printer Setup Utility (Mac OS 10.3.x), Print Center (Mac OS 10.2.x), or Chooser (Mac OS 9)	267
The font on the printout is different from that on the screen	267
The printer fonts cannot be installed	268
The edges of texts and/or images are not smooth.	268
The printer does not print normally via the parallel interface (Windows 98 only)	269
The printer does not print normally via the USB interface.	269
The printer does not print normally via the network interface	269

An undefined error occurs (Macintosh only)	271
Insufficient memory to print data (Macintosh only)	271
Printing in the PCL6 Mode Problems	272
The printer does not print	272
The font on the printout is different from that on the screen.	272
The edges of texts and/or images are not smooth	272

Appendix A Where To Get Help

Technical Support Web Site	273
Contacting Customer Support	273
Before Contacting Epson	273

Appendix B Technical Specifications

Paper	275
Available paper types	276
Paper that should not be used	276
Printable area	277
Printer	279
General	279
Environmental	280
Mechanical	280
Electrical	281
Standard and approvals	281
Interfaces	282
Parallel interface	282
USB interface	282
Ethernet interface	282
Options and Consumable Products	283
550-Sheet Universal Paper Cassette Unit	283
Duplex Unit	284
Memory module	284
Imaging cartridges	285
Fuser unit	285

Appendix C Information about Fonts

Working with Fonts 286

 EPSON BarCode Fonts (Windows Only) 286

 Available fonts 309

 Adding more fonts 317

 Selecting fonts 317

 Downloading fonts 317

 EPSON Font Manager (Windows Only) 318

Symbol Sets 320

 Introduction to symbol sets 320

 In the LJ4 Emulation Mode 321

 In the ESC/P 2 or FX Modes 325

 In the I239X Emulation Mode 328

 In the PCL6 Mode 328

Index

Safety Instructions

Safety

Warnings, Cautions, and Notes



Warnings

must be followed carefully to avoid bodily injury.



Cautions

must be observed to avoid damage to your equipment.

Notes

contain important information and useful tips on the operation of your printer.

Safety precautions

Be sure to follow the precautions carefully to ensure safe, efficient operation:

- ❑ Because the printer weighs approximately 19.5 kg (43 lb) without the imaging cartridge and optional products installed, one person should not lift or carry it. Two people should carry the printer, lifting it by the correct positions as shown below.

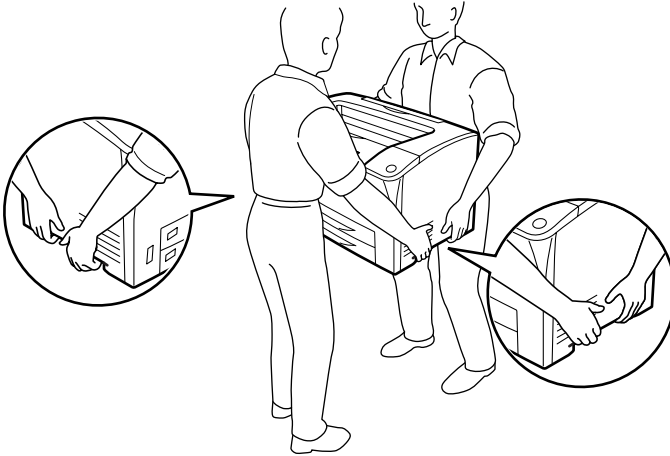

- ❑ Be careful not to touch the fuser, which is marked **CAUTION HOT SURFACE** and **CAUTION HIGH TEMPERATURE**, or the surrounding areas. If the printer has been in use, the fuser and the surrounding areas may be very hot. If you must touch one of these areas, wait 40 minutes to allow the heat to subside before doing so.

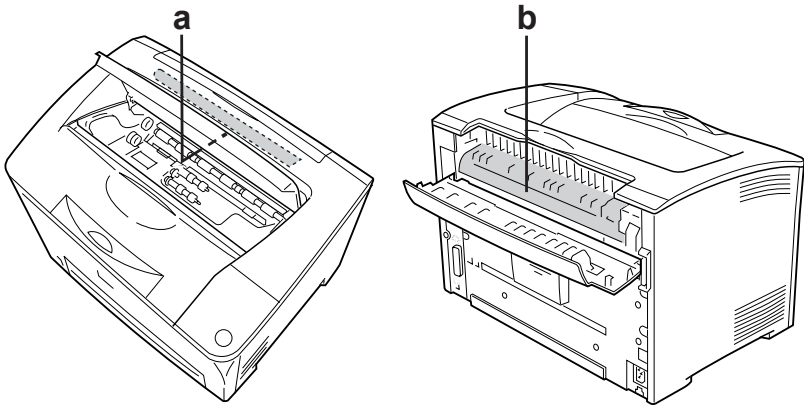

- a. **CAUTION HOT SURFACE**
- b. **CAUTION HIGH TEMPERATURE**

- ❑ Do not insert your hand deep into the fuser unit as some components are sharp and may cause injury.
- ❑ Avoid touching the components inside the printer unless instructed to do so in this guide.
- ❑ Never force the printer's components into place. Although the printer is designed to be sturdy, rough handling can damage it.
- ❑ When handling an imaging cartridge, always place it on a clean, smooth surface.
- ❑ Do not attempt to modify an imaging cartridge or take it apart. It cannot be refilled.

- ❑ Do not touch the toner. Keep the toner away from your eyes.
- ❑ Do not dispose of used imaging cartridges or fuser units in fire, as they can explode and cause injury. Dispose of them according to local regulations.
- ❑ If toner is spilled, use a broom and dustpan or a damp cloth with soap and water to clean it up. Because the fine particles can cause a fire or explosion if they come into contact with a spark, do not use a vacuum cleaner.
- ❑ Wait at least one hour before using an imaging cartridge after moving it from a cool to a warm environment to prevent damage from condensation.
- ❑ Do not open the drum's protective cover and avoid exposing an imaging cartridge to room light any longer than necessary. Overexposing the cartridge may cause abnormally dark or light areas to appear on the printer page and reduce the life of the cartridge.

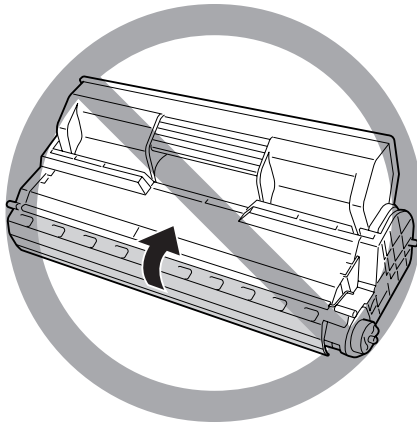

- ❑ To prevent damage from condensation, do not place the printer in a location subject to extreme or rapid changes in temperature or humidity, and do not move it from a cool to a warm environment.
- ❑ Be sure to keep consumable components out of the reach of children.
- ❑ Do not leave jammed paper inside the printer. This can cause the printer to overheat.
- ❑ Avoid sharing outlets with other appliances.
- ❑ Use only an outlet that meets the power requirements of this printer.

Important Safety Instructions

Read all of the following instructions before operating your printer:

When choosing a place and power source for the printer

- ❑ Place the printer near an electrical outlet where you can easily plug in and unplug the power cord.
- ❑ Do not place the printer on an unstable surface.
- ❑ Do not put your printer where the cord will be stepped on.
- ❑ Slots and openings in the cabinet and the back or bottom are provided for ventilation. Do not block or cover them. Do not put the printer on a bed, sofa, rug, or other similar surface or in a built-in installation unless proper ventilation is provided.
- ❑ All interface connectors for this printer are Non-LPS (non-limited power source).

- ❑ Connect your printer to an electrical outlet that meets the power requirements of this printer. Your printer's power requirements are indicated on a label attached to the printer. If you are not sure of the power supply specifications in your area, contact your local power company or consult your dealer.
- ❑ If you are unable to insert the AC plug into the electrical outlet, contact an electrician.
- ❑ Avoid using outlets that other appliances are plugged into.
- ❑ Use the type of power source indicated on the label. If you are not sure of the type of power available, consult your dealer or local power company.
- ❑ If you are unable to insert the plug into the outlet, contact a qualified electrician.
- ❑ When connecting this product to a computer or other device with a cable, ensure the correct orientation of the connectors. Each connector has only one correct orientation. Inserting a connector in the wrong orientation may damage both devices connected by the cable.
- ❑ If you use an extension cord, make sure that the total of the ampere ratings on the products plugged into the extension cord does not exceed the extension cord ampere rating.
- ❑ Unplug this printer from the wall outlet and refer servicing to a qualified service representative under the following conditions:
 - A. When the power cord or plug is damaged or frayed.
 - B. If liquid has been spilled into it.
 - C. If it has been exposed to rain or water.

- D. If it does not operate normally when the operating instructions are followed. Adjust only those controls that are covered by the operating instructions since improper adjustment of other controls may result in damage and will often require extensive work by a qualified technician to restore the product to normal operation.
- E. If it has been dropped or the cabinet has been damaged.
- F. If it exhibits a distinct change in performance, indicating a need for service.

When using the printer

- The printer weighs about 19.5 kg (43 lb). One person should not attempt to lift or carry the printer. Two people should carry it.
- Follow all warnings and instructions marked on the printer.
- Unplug this printer from the wall outlet before cleaning.
- Use a well-wrung cloth for cleaning and do not use liquid or aerosol cleaners.
- Do not use aerosol products that contain flammable gases inside or around this product. Doing so may cause fire.
- Avoid touching the components inside the printer unless instructed to do so in the printer's documentation.
- Never force printer components into place. Although the printer is designed to be sturdy, rough handling can damage it.
- Be sure to keep consumables out of the reach of children.

- ❑ Do not use printer in a damp environment.
- ❑ Do not leave jammed paper inside the printer. This can cause the printer to overheat.
- ❑ Never push objects of any kind through cabinet slots as they may touch dangerous voltage points or short out parts that could result in a risk of fire or electric shock.
- ❑ Never spill liquid of any kind on the printer.
- ❑ Except as specifically explained in the printer's documentation, do not attempt to service this product yourself.
- ❑ Adjust only those controls that are covered by the operating instructions. Improper adjustment of other controls may result in damage and may require repair by a qualified service representative.

ENERGY STAR[®] compliance



As an ENERGY STAR[®] Partner, Epson has determined that this product meets the ENERGY STAR[®] guidelines for energy efficiency.

The International ENERGY STAR[®] Office Equipment Program is a voluntary partnership with the computer and office equipment industry to promote the introduction of energy-efficient personal computers, monitors, printers, fax machines, copiers, scanners, and multifunction devices, and in an effort to reduce air pollution caused by power generation. Their standards and logos are uniform among participating nations.

Safety Information

Power cord



Caution:

Be sure the AC power cord meets the relevant local safety standards.

Use only the power cord that comes with this product. Use of the another cord may result in fire or electric shock.

This product's power cord is for use with this product only. Use with other equipment may result in fire or electric shock.

Laser safety labels



Warning:

The performance of procedures and adjustments other than those specified in the printer's documentation may result in hazardous radiation exposure.

Your printer is a Class 1 laser product as defined in the IEC60825 specifications. The label shown is attached to the back of the printer in countries where required.



Internal laser radiation

Max. Average Radiation Power: 5 mW at laser aperture

Wavelength: 770 to 800 nm

This is a Class III b Laser Diode Assembly that has an invisible laser beam. The printer head unit is NOT A SERVICE ITEM, therefore, the printer head unit should not be opened under any circumstances. An additional laser warning label is affixed to the inside of the printer.

Ozone safety

Ozone emission

Ozone gas is generated by laser printers as a by-product of the printing process. Ozone is produced only when the printer is printing.

Ozone exposure limit

The recommended exposure limit for ozone is 0.1 parts per million (ppm) expressed as an average time-weighted concentration over an eight (8) hour period. The Epson laser printer generates less than 0.1 ppm for eight (8) hours of continuous printing.

Minimize the risk

To minimize the risk of exposure to ozone, you should avoid the following conditions:

- Use of multiple laser printers in a confined area
- Operation in conditions of extremely low humidity
- Poor room ventilation
- Long, continuous printing together with any of the above

Printer location

The printer should be located so that the exhaust gases and heat generated are:

- ❑ Not blown directly into the user's face
- ❑ Vented directly out of the building whenever possible

Power On/Off Cautions

Do not turn off the printer:

- ❑ After turning on the printer, wait until **Ready** appears on the LCD panel.
- ❑ While the **Ready** light is flashing.
- ❑ While the **Data** light is on or flashing.
- ❑ While printing.

Getting to Know Your Printer

Where to Find Information

Setup Guide

Provides you with information on assembling the printer and installing the printer software.

User's Guide (this manual)

Provides you with detailed information on the printer's functions, optional products, maintenance, troubleshooting, and technical specifications.

Network Guide

Provides network administrators with information on both the printer driver and network settings. You need to install this guide from the Network Utilities CD-ROM to your computer's hard disk before referring it.

Paper Jam Guide

Provides you with solutions for paper jam problems about your printer you may need to refer to on a regular basis. We recommend printing this guide and keeping it near the printer.

Online Help for printer software

Click **Help** for detailed information and instructions on the printer software that controls your printer. Online help is automatically installed when you install the printer software.

Printer Parts

Front view

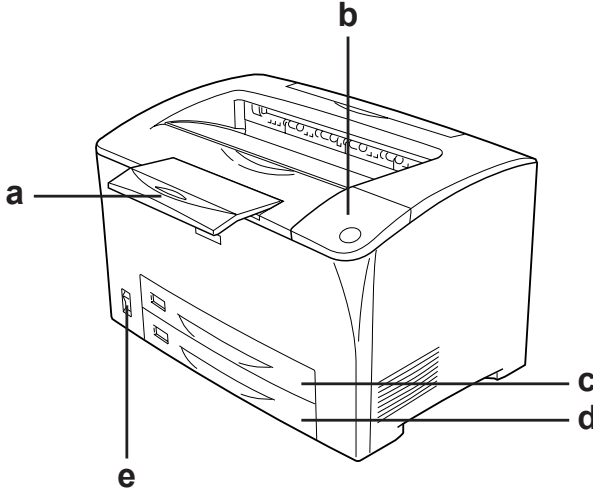

- a. paper support
- b. control panel
- c. MP tray (Multi-Purpose tray)
- d. standard lower paper cassette
- e. power switch

Rear view

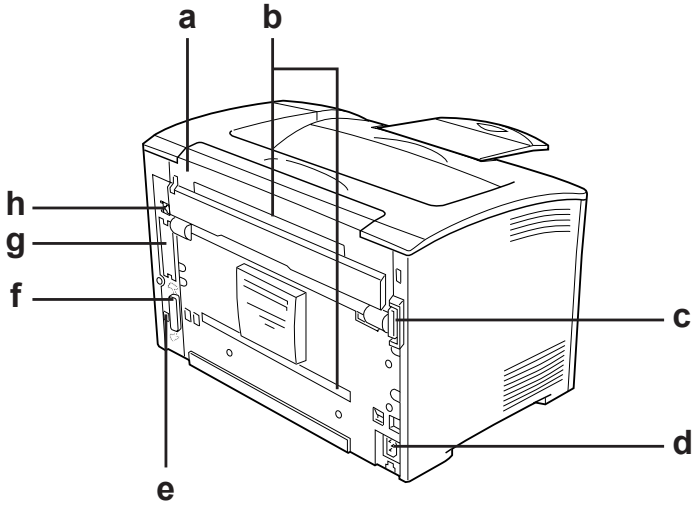

- a. cover B
- b. option covers
- c. duplex connector
- d. AC inlet
- e. USB interface connector
- f. parallel interface connector
- g. Type B interface and slot cover
- h. Ethernet interface connector

Inside the printer

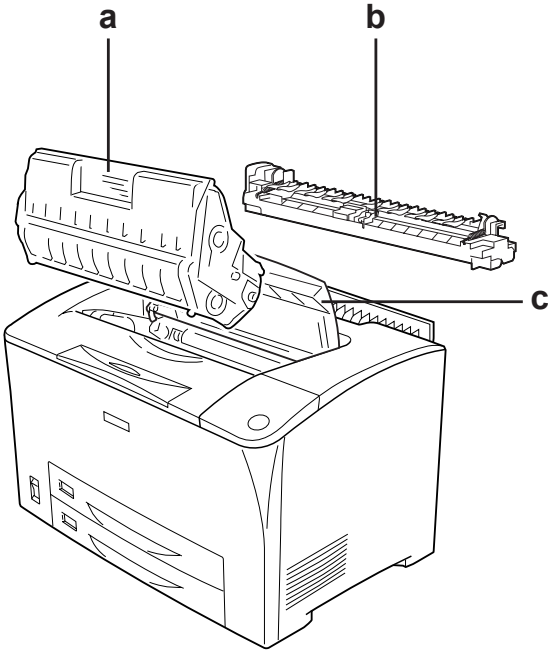

- a. imaging cartridge
- b. fuser unit
- c. cover A

Control panel

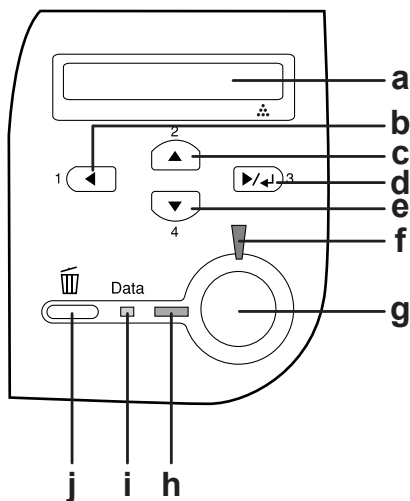

- | | | |
|----|-------------------|--|
| a. | LCD panel | Displays printer status messages and control panel menu settings. |
| b. | Back button | Use these buttons to access the control panel menus, where you can make printer settings and check the status of consumable products. For instructions on how to use these buttons, see "Using the Control Panel Menus" on page 149. |
| c. | Up button | |
| d. | Enter button | |
| e. | Down button | |
| f. | Error light (Red) | On or flashes when an error has occurred. |

- | | | |
|----|---------------------|--|
| g. | Start/Stop button | When the printer is printing, pressing this button stops the printing.
When the error light is flashing, pressing this button clears the error and switches the printer to ready status. |
| h. | Ready light (Green) | On when the printer is ready, indicating that the printer is ready to receive and print data.
Off when the printer is not ready. |
| i. | Data light (Orange) | On when print data is stored in the print buffer (the section of printer memory reserved for receiving data) but not yet printed.
Flashes when the printer is processing data.
Off when no data remains in the print buffer. |
| j. | Cancel Job button | Press once to cancel the current print job.
Press and hold for more than two seconds to delete all jobs from the printer memory. |

Options and Consumable Products

Options

You can add to your printer's capabilities by installing any of the following options.

- 550-Sheet Universal Paper Cassette Unit (C12C802002)
This unit holds one paper cassette. It increases paper-feeding capacity up to 550 sheets of paper.

- ❑ **Duplex Unit (C12C813982)**
This unit provides for automatic printing on both sides of the paper.

- ❑ **Memory Module**
This option expands the printer's memory by allowing you to print complex and graphics-intensive documents. The printer's RAM can be increased up to 320 MB by adding one additional 256 MB RAM DIMM.

Note:

Make sure that the DIMM you purchase is compatible with EPSON products. For details, contact the store where you purchased this printer or an EPSON qualified service representative.

Consumable products

The life of the following consumable products is monitored by the printer. The printer lets you know when replacements are needed.

Product name	Product code
Imaging Cartridge	0290
Fuser unit	3023

Printer Features and Various Printing Options

Printer Features

The printer comes with a full set of features that contributes to ease of use and consistent, high-quality output. The main features are described below.

High-quality printing

When using the driver provided, your printer does 1200 RIT* printing at a speed of up to 30 ppm (pages per minute) when printing on A4 paper. You'll appreciate the professional print quality produced by your printer and its quick processing speed.

* Resolution Improvement Technology

Toner save mode

To reduce the amount of toner used in printing documents, you can print rough drafts using the Toner Save mode.

Resolution Improvement Technology (RITech)

Resolution Improvement Technology (RITech) is an original Epson printer technology that improves the appearance of printed lines, text, and graphics.

Wide variety of fonts

The printer comes with a selection of 95 Laser-Jet-compatible scalable fonts, and 5 bitmap fonts in LJ4 emulation mode to provide you with the fonts you need to create professional-looking documents.

Adobe PostScript 3 Mode

The printer's Adobe PostScript 3 Mode provides you with the ability to print documents formatted for PostScript printers. Seventeen scalable fonts are included. IES (Intelligent Emulation Switch) and SPL (Shared Printer Language) support allow the printer to switch between the PostScript mode and other emulations as print data is received at the printer.

PCL6 Emulation Mode

The PCL6 Emulation mode provides you with the ability to print documents in the PCL6/5e printing language with this printer.

Various Printing Options

This printer provides you with a variety of different printing options. You can print in various formats, or can print using many different types of paper.

The following explains the procedure for each type of printing. Choose the appropriate one for your printing.

Double-sided printing

"Duplex Unit" on page 198

"Duplex printing" on page 65



Lets you print on both sides of the paper.

Note:

You need an optional Duplex Unit installed on your printer in order to automatically print on both sides of the paper.

Fit to page printing

"Resizing printouts" on page 68

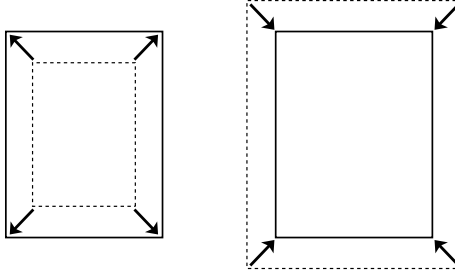

Lets you automatically enlarge or reduce the size of your document to fit the paper size you selected.

Pages per sheet printing

"Modifying the print layout" on page 71

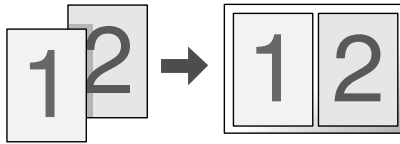

Lets you print two or four pages on a single sheet.

Watermark printing

"Using a watermark" on page 73



Lets you print text or an image as a watermark on your printout. For example, you can put "Confidential" on an important document.

Overlay printing

"Using an overlay" on page 76

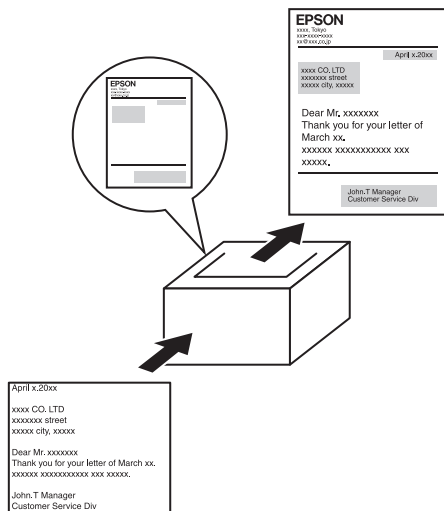

Lets you prepare standard forms or template on your printout that you can use as overlays when printing other documents.

Note:

The Overlay printing function is not available in the PostScript 3 mode.

Web-Page Printing

EPSON Web-To-Page lets you make Web pages fit to your paper size when printing. You can also see a preview before printing.

Note:

- This software is for Windows only.*
- Install EPSON Web-To-Page from the printer software CD-ROM to use this function.*

Accessing EPSON Web-To-Page

After you install EPSON Web-To-Page, the menu bar is displayed on the Microsoft Internet Explorer Toolbar. If it does not appear, select Toolbars from the View menu of Internet Explorer, and then select EPSON Web-To-Page.

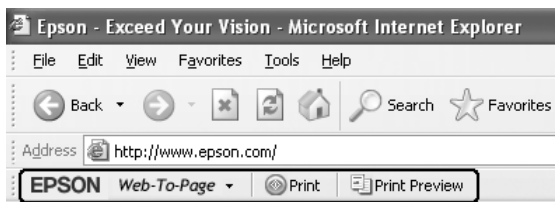

Chapter 3

Paper Handling

Paper Sources

This section describes the combinations of paper sources and paper types that you can use.

MP tray

Paper Type	Paper Size	Capacity
Plain paper Weight: 60 to 90 g/m ²	A3, A4, A5, Letter (LT), B4, B5, Half-Letter (HLT), Executive (EXE), Legal (LGL), Government Letter (GLT), Government Legal (GLG), B (Ledger), F4 Custom-size paper: 76.2 × 98.4 mm minimum 304.8 × 508 mm maximum	Up to 150 sheets (75 g/m ²) Up to 200 sheets (64 g/m ²) (Total thick stack: up to 17.5 mm)
Envelopes	Monarch (MON), C10, DL, C5, C6, IB5	Up to 10 envelopes (Total thick stack: up to 17.5 mm)
Labels	A4, Letter (LT)	Up to 75 sheets

Thick paper/Extra thick paper Weight: 91 to 216 g/m ²	A3, A4, A5, Letter (LT), B4, B5, Half-Letter (HLT), Executive (EXE), Legal (LGL), Government Letter (GLT), Government Legal (GLG), B (Ledger), F4 Custom-size paper: 76.2 × 98.4 mm minimum 304.8 × 508 mm maximum	Up to 17.5 mm thick stack
Transparencies	A4, Letter (LT)	Up to 100 sheets

Standard lower paper cassette

Paper Type	Paper Size	Capacity
Plain paper Weight: 60 to 90 g/m ²	A3, A4, A5, B4, B5, Letter (LT), Legal (LGL)	Up to 250 sheets (Total thick stack: up to 27.6 mm)

550-Sheet Universal Paper Cassette Unit

Paper Type	Paper Size	Capacity
Plain paper Weight: 60 to 90 g/m ²	A3, A4, A5, B4, B5, Letter (LT), Legal (LGL)	Up to 550 sheets (Total thick stack: up to 59.4 mm)

Selecting a paper source

You can specify a paper source manually, or set the printer to select the paper source automatically.

Manual selection

You can use the printer driver or the printer's control panel to select a paper source manually.

To access the printer driver, see "Accessing the printer driver" on page 58.

And to use the printer's control panel, see "Using the Control Panel Menus" on page 149.

Using the printer driver:

- Access the printer driver, click the Basic Settings tab, and select the paper source that you want to use from the Paper Source list. Then click OK.

Using the printer's control panel:

- Access the control panel's Setup Menu, then select `Paper Source` and specify the paper source you want to use.

Auto selection

You can use the printer driver or the printer's control panel to select a paper source containing the appropriate size of paper automatically.

To access the printer driver, see "Accessing the printer driver" on page 58.

And to use the printer's control panel, see "Using the Control Panel Menus" on page 149.

Using the printer driver:

- Access the printer driver, click the Basic Settings tab, and select Auto Selection as the paper source. Then click OK.

Using the printer's control panel:

- Access the control panel's Setup Menu, and select `Paper Source`, then select `Auto`.

The printer will search for a paper source containing the specified paper size in the following order.

Standard configuration:

MP tray
Lower Cassette 1

With one or two optional 550-Sheet Universal Paper Cassette Units installed:

MP tray
Lower Cassette 1
Lower Cassette 2
Lower Cassette 3

Note:

- If you make paper size settings or paper source settings in your application, these settings may override the printer driver settings.*
- If you select an envelope for the Paper Size setting, it can be fed only from the MP tray regardless of the Paper Source setting.*
- You can change the priority of the MP tray by using the MP Mode setting in the control panel's Setup Menu. For details, see "Setup Menu" on page 158.*

Loading Paper

This section describes how to load paper into the MP tray and the standard lower paper cassette. If you use special media such as transparencies or envelopes, see also "Printing on Special Media" on page 50.

You can load various paper sizes by expanding the MP tray or standard lower paper cassette as shown in the illustration below.

For MP tray

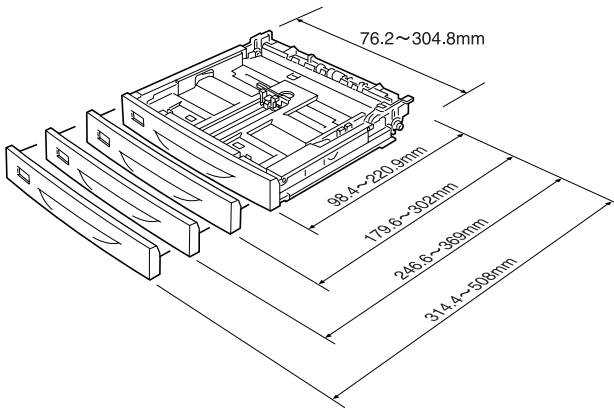

Note:

When loading 432 mm or longer size paper into the MP tray, remove the MP tray cover and let the bottom edge of the paper stick out. For details, see "Loading a custom paper size" on page 56.

For standard lower paper cassette

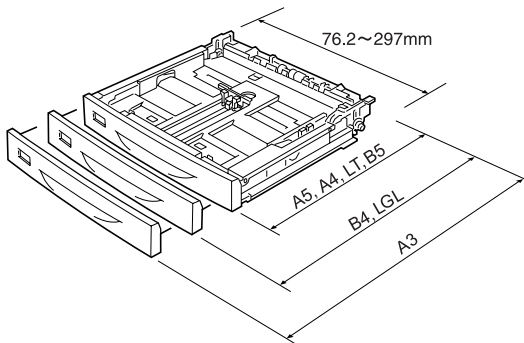

MP tray and standard lower paper cassette

The MP tray is the most flexible paper source, accommodating various paper sizes and paper types. See "MP tray" on page 38 for details.

For information on the paper sizes and types supported by the standard lower paper cassette, see "Standard lower paper cassette" on page 39.

Note:

MP tray can be set into the upper paper cassette slot only, and standard lower paper cassette can be set into the lower paper cassette slot only. Do not set into the different slot by force.

Follow these steps to load paper into the MP tray.

Note:

The procedure for loading paper into the standard lower paper cassette is the same as that for the MP tray.

1. Pull out the MP tray.

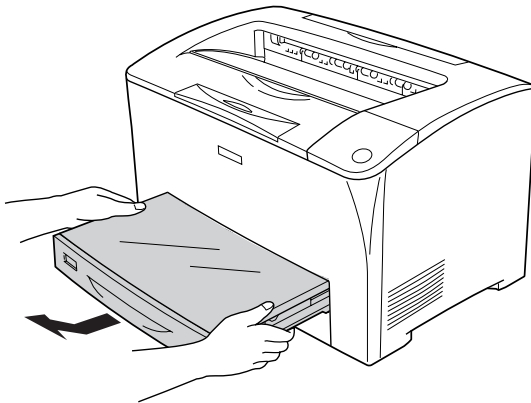

2. Remove the MP tray cover.

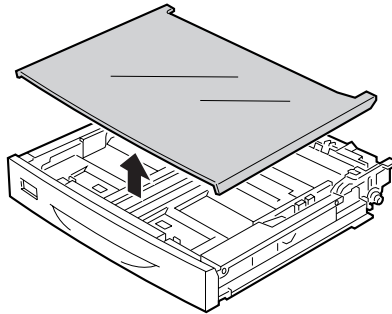

3. Adjust the paper cassette size to accommodate the paper you are loading.

When loading A4, Letter (LT), B5, or A5 size paper

Slide the side paper guide outward while pinching the knob. Then, slide the end paper guide while pinching the knob, to accommodate the paper you are loading.

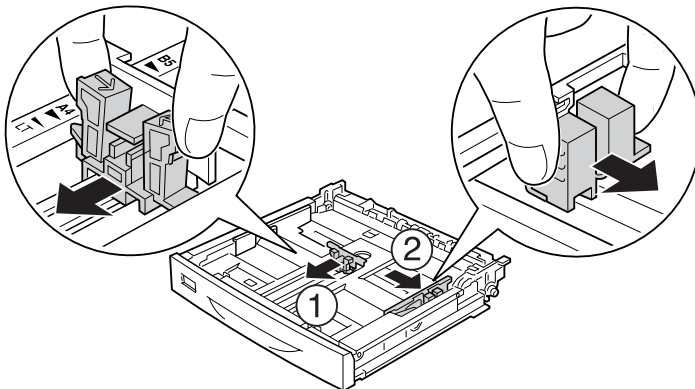

When loading A3, B4, Legal (LGL) size paper

Unlock the lock levers.

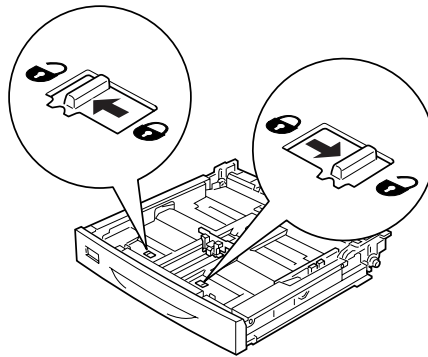

Expand the paper cassette to accommodate the paper you are loading, and lock the lock levers.

Note:

When loading A3 size paper, expand the paper cassette all the way out until the A3 arrow mark is aligned opposite with the arrow mark below the lock lever. When loading B4 or Legal (LGL) size paper, expand the paper cassette until the B4/LG14 arrow mark is aligned opposite with the arrow mark below the lock lever.

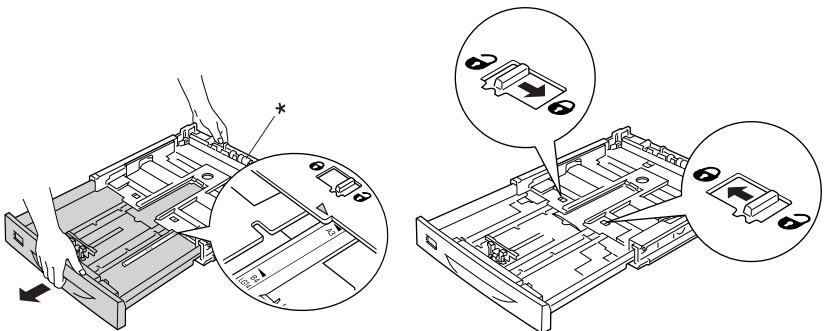

* Do not hold the roller when expanding the paper cassette. Doing so may damage the paper cassette.

Slide the side paper guide outward while pinching the knob. Then, slide the end paper guide while pinching the knob, to accommodate the paper you are loading.

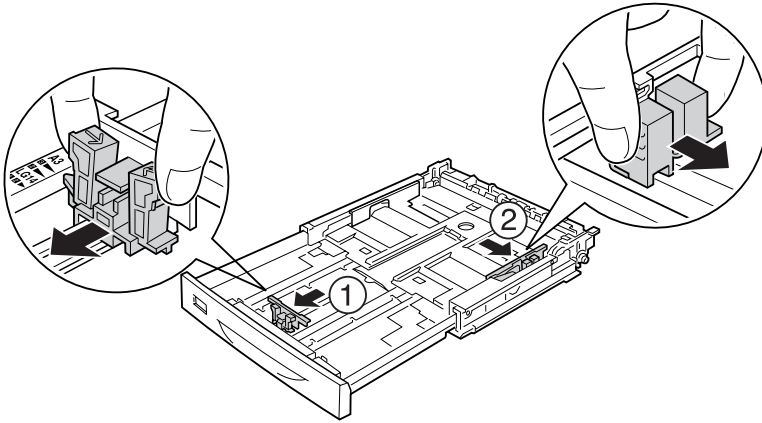

4. Load a stack of the desired paper on the center of the paper cassette with the printable surface facing up. Then slide the side paper guide while pinching the knob until it is against the right side of the stack to get a snug fit.

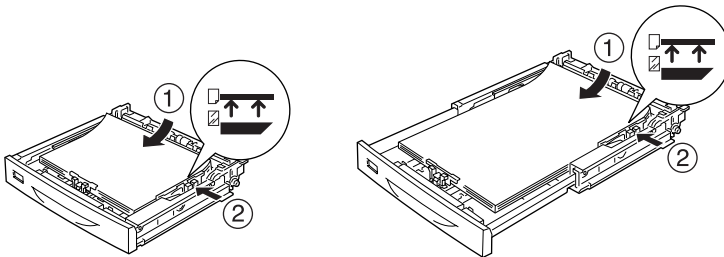

5. Set the paper cassette label into the label holder on the front of the paper cassette.

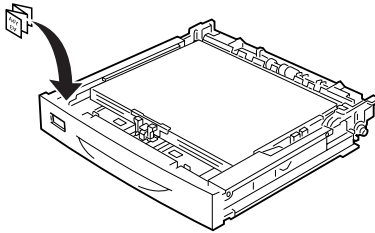

6. Replace the MP tray cover, making sure the front edge is flush and as far forward as possible. And reinsert the paper cassette in the printer.

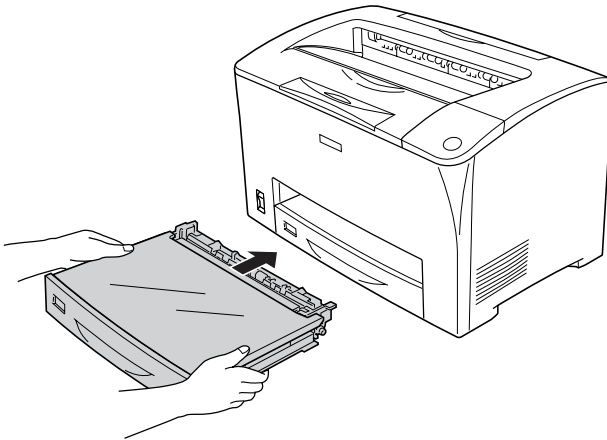
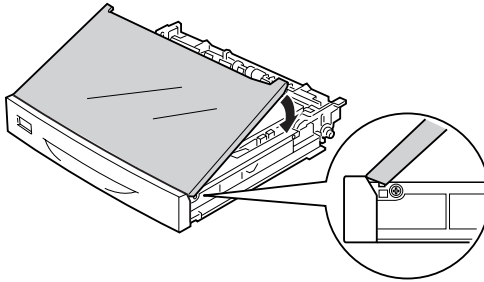

Note:

- ❑ When loading paper that is 432 mm or longer, you do not have to reattach the MP tray cover. For details, see "Loading a custom paper size" on page 56.
- ❑ The following paper sizes are detected automatically. When loading other paper sizes or fixing the paper size despite the loaded paper size, use the control panel to set the paper size. For details, see "Tray Menu" on page 153.

Detected paper sizes:

MP tray: A3, A4, A5, B4, B5, Letter (LT),
Legal (LGL)

Standard lower paper cassette: A3, A4, A5, B4, B5, Letter (LT),
Legal (LGL)

7. Extend the paper support to accommodate the size of the paper loaded in the lower paper cassette to prevent it from slipping off the printer.

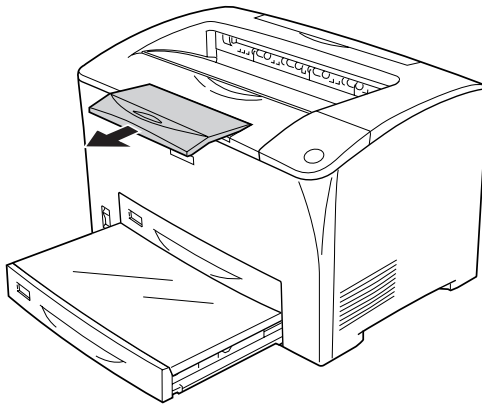

550-Sheet Universal Paper Cassette Unit

The paper sizes and types supported by the optional 550-Sheet Universal Paper Cassette Unit are the same as the standard lower paper cassette. For more information, see "550-Sheet Universal Paper Cassette Unit" on page 39.

The paper-loading procedure is also the same as that for the standard lower paper cassette. For detailed information, see "MP tray and standard lower paper cassette" on page 43.

Output tray

The face-down tray is located on the top of the printer. Your printouts will be stacked facing down.

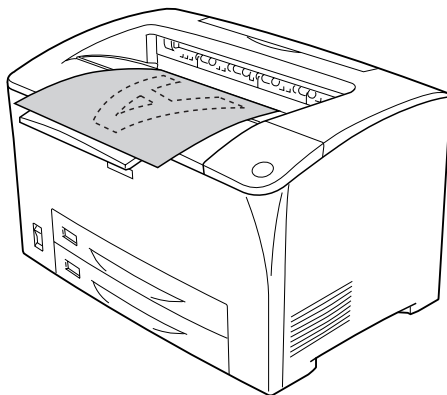

You can use the face-down tray with the following types of paper.

Paper type: All types of paper that are supported can be used.

Capacity: Up to 250 sheets of plain paper

When printing on B4 or larger size paper, pull out the paper support to prevent your printouts from slipping off the printer.

Printing on Special Media

You can print on special media such as thick paper, envelopes, transparencies, and labels.

Note:

Since the quality of any particular brand or type of media may be changed by the manufacturer at any time, Epson cannot guarantee the quality of any type of media. Always test samples of media stock before purchasing large quantities or printing large jobs.

Envelopes

The print quality of envelopes may be irregular because different parts of an envelope have different thicknesses. Print one or two envelopes to check the print quality.



Caution:

Do not use window envelopes. The plastic on most window envelopes will melt when it comes into contact with the fuser.

Note:

- ❑ *Duplex printing is not available for envelopes.*
- ❑ *Depending on the quality of envelopes, the printing environment, or the printing procedure, envelopes might be wrinkled. Make a trial print run before you print on a lot of envelopes.*

- ❑ *When printed envelopes are wrinkled, open Cover B and push up the form feed pressure change levers at both sides of the fuser unit until they are in the vertical position. It may reduce the wrinkles in the envelopes. When using paper other than envelopes, be sure to push the levers back down.*

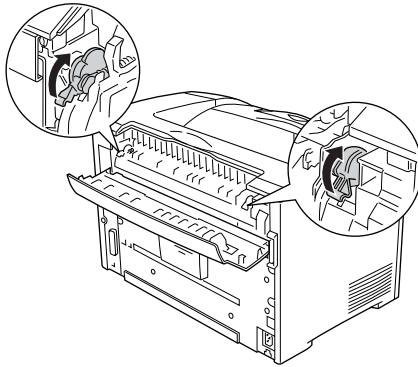

Warning:

Unless specifically instructed in this guide, be careful not to touch the fuser, which is marked CAUTION HOT SURFACE and CAUTION HIGH TEMPERATURE, or the surrounding areas. If the printer has been in use, the fuser and the surrounding areas may be very hot. If you must touch one of these areas, wait 40 minutes to allow the heat to subside before doing so.

When loading envelopes, you should make paper settings as shown below:

Paper Source	MP tray (up to 10 envelopes)
MP Tray Size setting in the Tray Menu	Mon, C10, DL, C5, C6, IB5
Printer driver settings	Paper Size: Mon, C10, DL, C5, C6, IB5 Paper Source: MP tray

Note:

When printing on envelopes, set the envelope size on the MP Tray Size setting in the Tray Menu on the control panel.

Please note the following tips for handling this media.

- ❑ Load envelopes with the flap closed and facing forward as shown below.

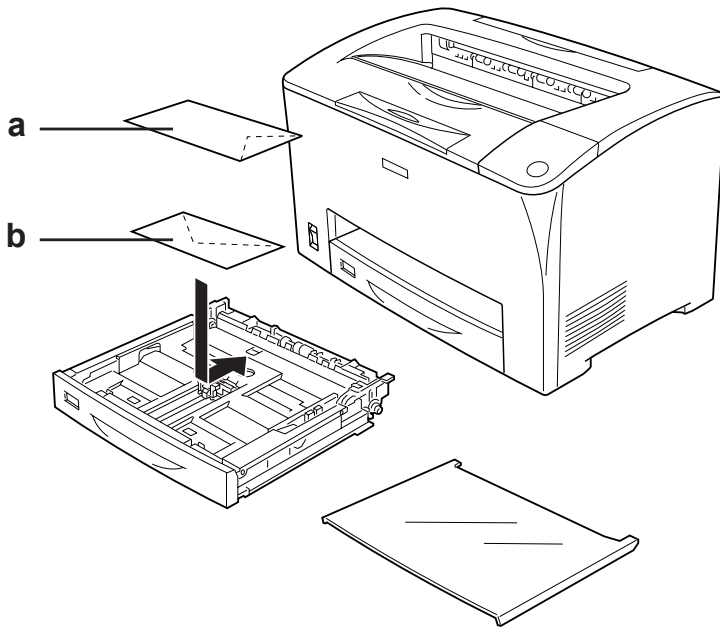

- a. C5, IB5
- b. DL, C6, C10, MON

- ❑ Do not use an envelope that has glue or tape on it.



Caution:

Make sure that the minimum size of envelopes meets the following size requirements:

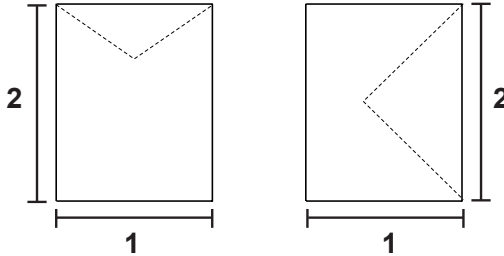

1. Min. 76.20 mm
2. Min. 98.40 mm

Labels

You can load up to 17.5 mm thick stack of labels into the MP tray at a time. However, you may need to feed some labels one sheet at a time, or load them manually.

Note:

- Duplex printing is not available for labels.
- Depending on the quality of labels, the printing environment, or the printing procedure, labels might be wrinkled. Make a trial print run before you print on a lot of labels.

When loading labels, you should make paper settings as shown below:

Paper Source	MP tray (up to 75 sheets)
MP Tray Size setting in the Tray Menu	Auto (or A4, LT)

Printer driver settings	Paper Size: A4, LT Paper Source: MP tray Paper Type: Labels
-------------------------	---

Note:

- ❑ *You should only use labels designed for laser printers or plain-paper copiers.*
- ❑ *To prevent the label adhesive from coming into contact with printer parts, always use labels that completely cover the backing sheet, with no gaps between the individual labels.*
- ❑ *Press a sheet of paper on top of each sheet of labels. If the paper sticks, do not use those labels in your printer.*
- ❑ *You may have to make the setting Thick* for Paper Type in the Setup Menu.*
** When using especially thick labels, set Paper Type to ExtraThk.*

Thick paper and extra thick paper

When loading thick or extra thick paper, you should make paper settings as shown below:

Paper Source	MP tray (up to 17.5 mm thick stack)
Printer driver settings	Paper Size: A3, A4, A5, B4, B5, LT, HLT, EXE, LGL, GLG, B, GLT, F4 Paper Source: MP tray Paper Type: Thick (for 90 to 157 g/m ² paper) or Extra Thick (for 157 to 216 g/m ² paper)

Note:

Using extra thick paper with the Duplex Unit may cause paper jams. Print each side of the paper separately when using extra thick paper.

Transparencies

When loading transparencies, you should make paper settings as shown below:

Paper Source	MP tray (up to 100 sheets)
MP Tray Size setting in the Tray Menu	Auto (or A4, LT)
Printer driver settings	Paper Size: A4, LT Paper Source: MP tray Paper Type: Transparency

Loading a custom paper size

You can load non-standard size paper into the MP tray as long as it meets the following size requirements:

76.2 × 98.4 mm to 304.8 × 508.0 mm

When loading a custom paper size, you should make paper settings as shown below:

Paper Source	MP tray (up to 150 sheets (75 g/m ²), up to 200 sheets (64 g/m ²))
Printer driver settings	Paper Size: User Defined Size Paper Source: MP tray Paper Type: Plain or Thick

When loading 432 mm or longer size paper into the MP tray, remove the MP tray cover and let the bottom edge of the paper stick out as shown below.

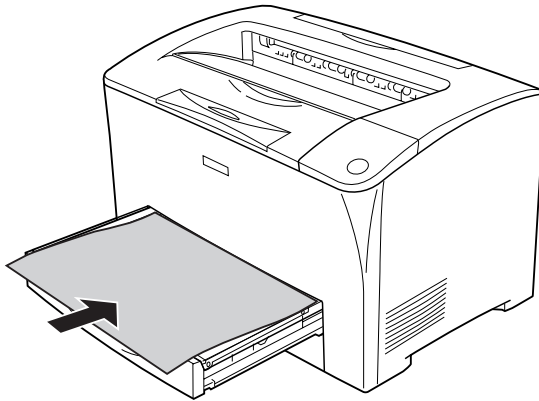

Note:

- ❑ *Access the printer driver, then select User-Defined Size from the Paper Size list on the Basic Settings tab. In the User Defined Paper Size dialog box, adjust the Paper Width, Paper Length, and Unit settings to match your custom paper. Then click OK and your custom paper size will be saved.*

- ❑ *If you cannot use the printer driver as explained above, make this setting at the printer by accessing the control panel's Printing Menu and selecting CTM (custom) as the Page Size setting.*

About the Printer Software

The printer driver lets you choose from a wide variety of settings to get the best results from your printer. EPSON Status Monitor lets you check the status of your printer.

See "Monitoring Your Printer Using EPSON Status Monitor" on page 86 for more information.

Accessing the printer driver

You can access the printer driver directly from any application programs, from your Windows operating system.

The printer settings made from many Windows applications override the setting made when the printer driver is accessed from the operating system, so you should access the printer driver from your application to make sure that you get the result you want.

Note:

The printer driver's online help provides details on printer driver settings.

From the application

To access the printer driver, click the Print or Page Setup from the File menu. You also need to click Setup, Options, Properties, or a combination of these buttons.

Windows XP or Server 2003 users

To access the printer driver, click Start, click Printers and Faxes, then click Printers. Right-click your printer's icon, then click Printing Preferences.

Windows Me or 98 users

To access the printer driver, click Start, point to Settings, then click Printers. Right-click your printer's icon, then click Properties.

Windows 2000 users

To access the printer driver, click Start, point to Settings, then click Printers. Right-click your printer's icon, then click Printing Preferences.

Making Changes to Printer Settings

Making the print quality settings

You can change the print quality of printouts through settings in the printer driver. With the printer driver, you can make the print settings by choosing from a list of predefined settings, or customizing the settings.

Choosing the print quality by using the Automatic setting

You can change the print quality of printouts to favor speed or detail.

When Automatic is selected on the Basic Settings tab, the printer driver takes care of all detailed settings according to the setting you select. Print quality is the only setting you have to make. You can change other settings such as paper size or orientation in most applications.

Note:

The printer driver's online help provides details on printer driver settings.

1. Click the Basic Settings tab.
2. Click Automatic, then choose desired printing quality.

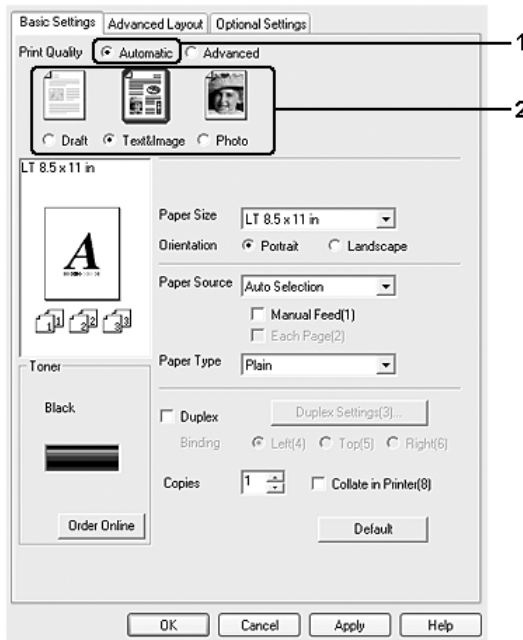

3. Click OK to apply the settings.

The printer driver provides the following quality modes.

Draft, Text&Image, Photo

Note:

If printing is unsuccessful or a memory-related error message appears, selecting a different print quality may allow printing to proceed.

Using the predefined settings

The predefined settings are provided to help you optimize print settings for a particular kind of printout, such as presentation documents or images taken by a video or digital camera.

Follow the steps below to use the predefined settings.

1. Click the Basic Settings tab.
2. Select Advanced. You will find the predefined settings in the list below of Automatic.

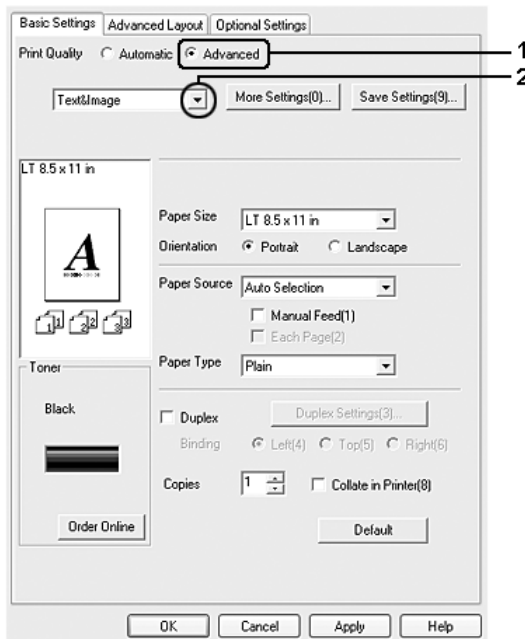

Note:

This screen may vary depending on your operating system version.

3. Select the most appropriate setting from the list according to the type of document or image you want to print.

When you choose a predefined setting, other settings such as Resolution and Graphics are set automatically. Changes are shown in the current settings list on the Setting Information dialog box that appears by pressing the Setting Info. button on the Optional Settings tab.

This printer driver provides the following predefined settings:

Draft

Suitable for printing inexpensive drafts.

Text & Image

Suitable for printing documents that include text and images.

Photo

Suitable for printing photos.

Customizing print settings

If you need to change detailed settings, make the settings manually.

Follow the steps below to customize your print settings.

1. Click the Basic Settings tab.
2. Click Advanced, then click More Settings.

3. Choose the desired printing resolution with the Resolution slider bar, then select the Graphics settings.

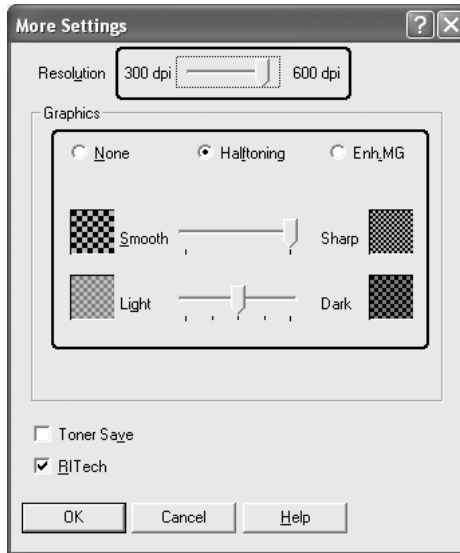

Note:

- ❑ *This screen may vary depending on your operating system version.*
 - ❑ *When making the other settings, see online help for details on each setting.*
4. Click OK to apply the settings and return to the Basic Settings tab.

Saving your settings

To save your custom settings, click **Advanced**, then click **Save Settings** on the **Basic Settings** tab. The **Custom Settings** dialog box appears.



Type a name for your custom settings in the **Name** box, then click **Save**. Your settings will appear in the list below of **Automatic** on the **Basic Settings** tab.

Note:

- ❑ *You cannot use a predefined setting name for your custom settings.*
- ❑ *To delete a custom setting, click **Advanced**, click **Save Settings** on the **Basic Settings** tab, select the setting in the **Custom Settings** dialog box, then click **Delete**.*
- ❑ *You cannot delete predefined settings.*

If you change any setting in the **More Settings** dialog box when one of your custom settings is selected in the **Advanced Settings** list on the **Basic Settings** tab, the setting selected in the list changes to **Custom Settings**. The custom setting that was previously selected is not affected by this change. To return to your custom setting, simply reselect it from the current settings list.

Duplex printing

Duplex printing prints on both sides of the paper. When printing for binding, the binding edge can be specified as required to produce the desired page order.

Printing with the Duplex Unit

Follow the steps below to print with the Duplex Unit.

1. Click the Basic Settings tab.
2. Select the Duplex check box, then select Left, Top, or Right as the Binding position.

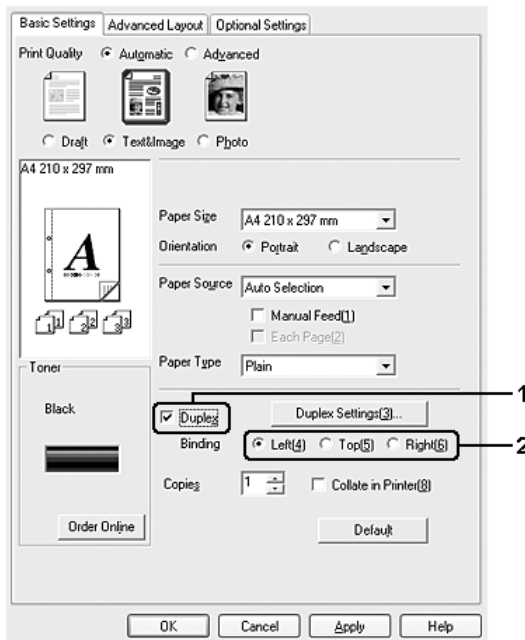

3. Click Duplex Settings to open the Duplex Settings dialog box.

- Specify the Binding Margin for the front and back sides of the paper, then select whether the front or back side of the paper is to be printed as the Start Page.

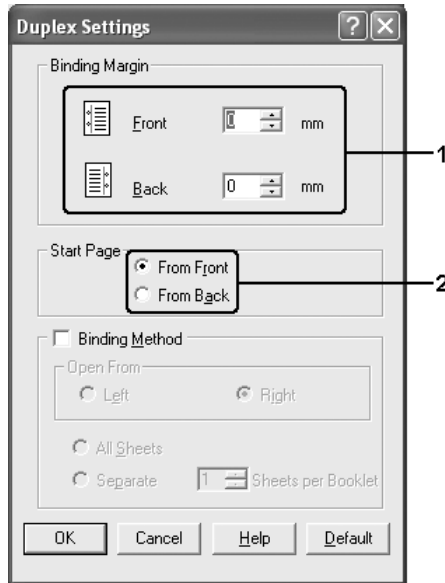

- When printing for binding as a booklet, select the Binding Method check box and make appropriate settings. For details about each setting, see online help.
- Click OK to apply the settings and return to the Basic Settings tab.

Displaying information about consumables with the printer driver

The amount of toner remaining is displayed on the Basic Settings tab when EPSON Status Monitor is installed. The Order Online button is also available. You can set the interval at which the information about the consumables is updated on the Consumables Info Settings dialog box that appears by clicking the Consumables Info Settings button on the Optional Settings tab.

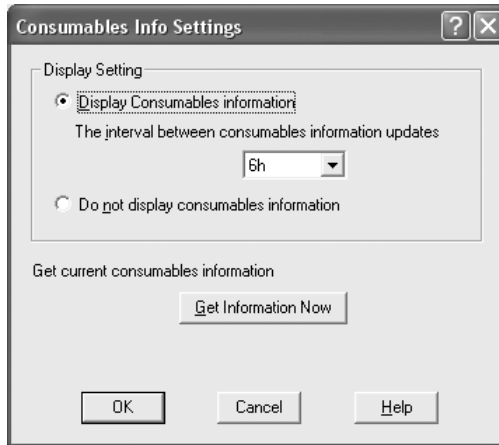

Note:

- ❑ *The driver and EPSON Status Monitor use different methods to measure the amount of toner remaining in the cartridge. Because of this, the information that is displayed in EPSON Status Monitor and the Basic Settings tab might be different. Use EPSON Status Monitor to get more detailed information.*

- ❑ *The country/region and URL for a web site must be specified when installing EPSON Status Monitor to use the function for ordering consumables online.*

Ordering Consumables

To order consumables online, click the Order Online button on the Basic Settings tab. See "Order Online" on page 100 for details.

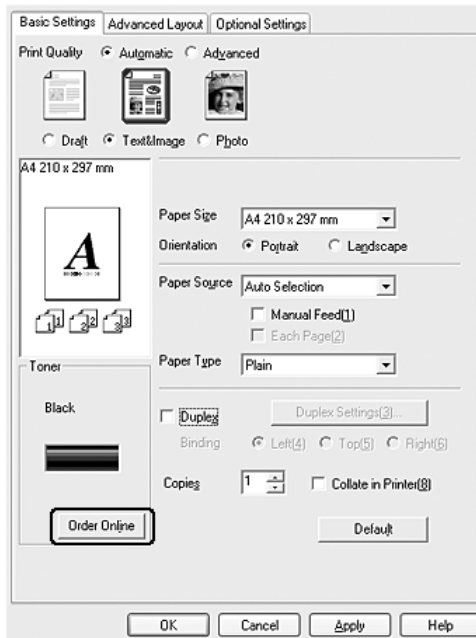

Resizing printouts

You can have your document enlarged or reduced during printing.

To automatically resize pages to fit the output paper

1. Click the Advanced Layout tab.

2. Select the Zoom Options check box, then select the desired paper size from the Output Paper drop-down list. The page will be printed to fit on the paper you have selected.

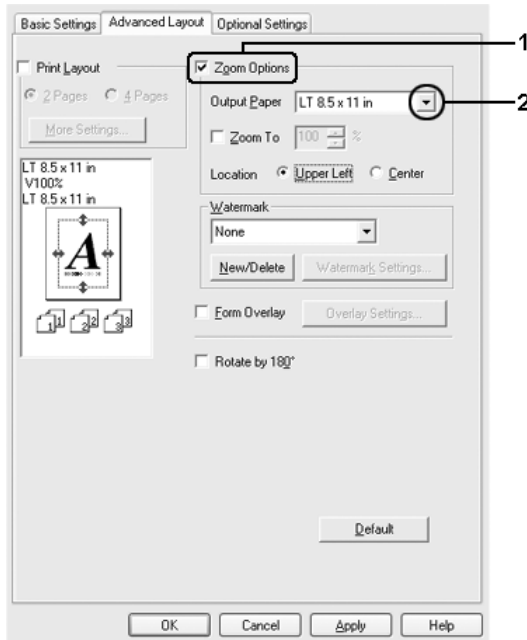

3. Select Upper Left (to print reduced page image at upper left corner of the paper) or Center (to print reduced page image with centering) for Location setting.
4. Click OK to apply the settings.

Resizing pages by a specified percentage

1. Click the Advanced Layout tab.
2. Select the Zoom Options check box.

3. Select the ZOOM TO check box, then specify the magnification percentage in the box.

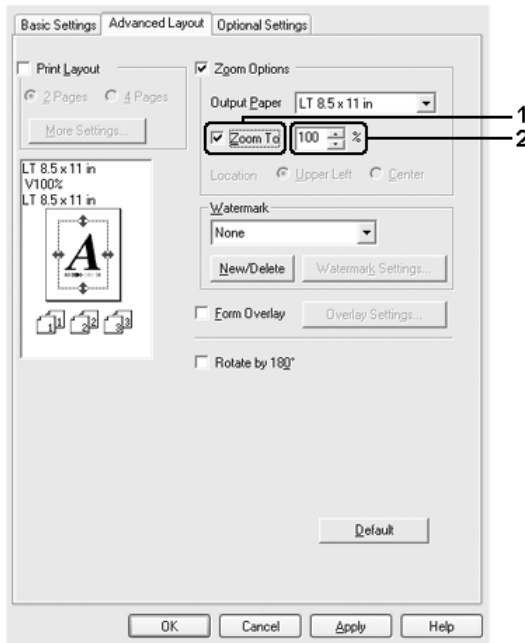

Note:

The percentage can be set between 50% and 200% in 1% increments.

4. Click OK to apply the settings.

If necessary, select the paper size to be printed from the Output Paper drop-down list.

Modifying the print layout

Your printer can print either two or four pages onto a single page and specifies the printing order, automatically resizing each page to fit the specified paper size. You can also choose to print documents surrounded by a frame.

1. Click the Advanced Layout tab.
2. Select the Print Layout check box and the number of pages you want to print on one sheet of paper. Then click More Settings. The Print Layout Settings dialog box appears.

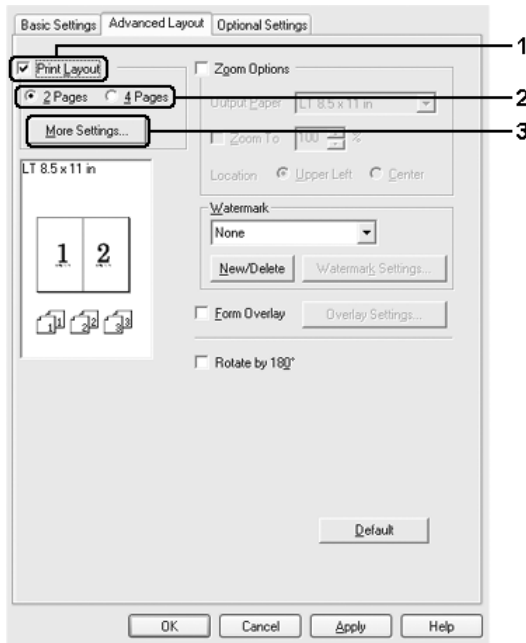

3. Select the Page Order in which the pages are printed on each sheet.

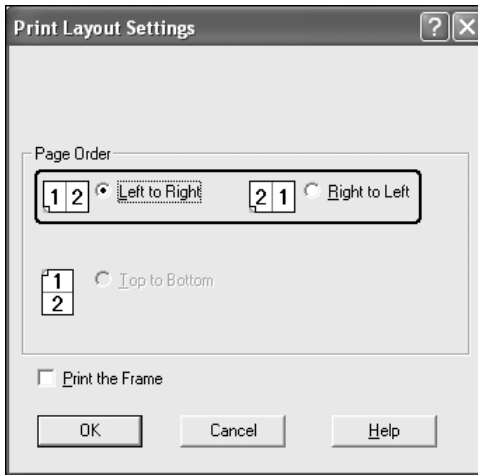

4. Select the Print the Frame check box when you want to print the pages surrounded by a frame.

Note:

The Page Order choices depend on the number of pages selected above, and the paper orientation (Portrait or Landscape) selected on the Basic Settings tab.

5. Click OK to apply the settings and return to the Advanced Layout tab.

Using a watermark

Follow the steps below to use a watermark on your document. On the Advanced Layout tab or Watermark dialog box, you can select from a list of predefined watermarks, or you can make an original watermark with text or a bitmap. The Watermark dialog box also allows you to make a variety of detailed watermark settings. For example, you can select the size, intensity, and position of your watermark.

1. Click the Advanced Layout tab.
2. Select a watermark that you want to use from the Watermark drop-down list. If you want to make detailed settings, click Watermark Settings. The Watermark dialog box appears.

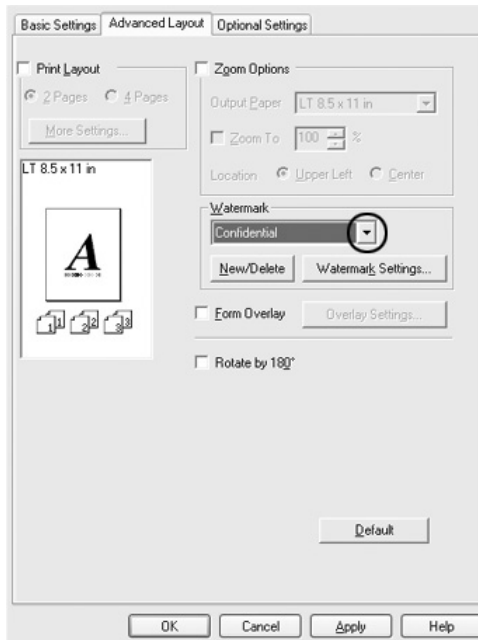

3. Adjust the image intensity of the watermark with the Intensity slider bar.

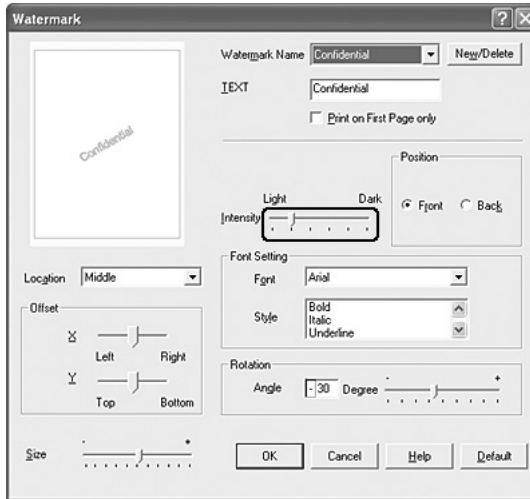

4. Select Front (to print the watermark in the foreground of the document) or Back (to print the watermark in the background of the document) for the Position setting.
5. Select the location on the page where you want to print the watermark from the Location drop-down list.
6. Adjust the X (horizontal) or Y (vertical) Offset position.
7. Adjust the size of the watermark with the Size slider bar.
8. Click OK to apply the settings and return to the Advanced Layout tab.

Making a new watermark

You can make a new watermark as follows:

1. Click the Advanced Layout tab.

2. Click New/Delete. The User Defined Watermarks dialog box appears.

Note:

The User Defined Watermarks dialog box also appears by clicking New/Delete in the Watermark dialog box.

3. Select Text or BMP and type a name for the new watermark in the Name box.

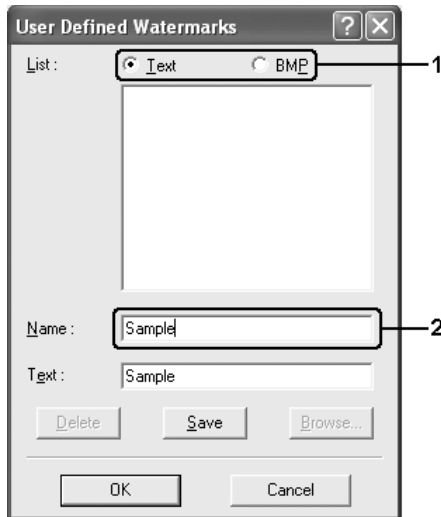

Note:

This screen appears when you select Text.

4. If you select Text, type the watermark text in the Text box. If you select BMP, click Browse, select the BMP file you want to use, then click OK.
5. Click Save. Your watermark will appear in the List box.
6. Click OK to apply the new watermark settings.

Note:

You can register up to 10 watermarks.

Using an overlay

The Overlay Settings dialog box allows you to prepare standard forms, or templates, that you can use as overlays when printing other documents. This feature can be useful for creating corporate letterheads or invoices.

Note:

The overlay function is available only when High Quality (Printer) is selected for the Printing Mode in the Extended Settings dialog box from the Optional Settings tab.

Creating an overlay

Follow the steps below to create and save a form overlay file.

1. Open your application and create the file that you want to use as an overlay.
2. When the file is ready to be saved as an overlay, choose Print or Print Setup from the File menu of your application, then click Printer, Setup, Options, Properties, or a combination of these buttons, depending on your application.
3. Click the Advanced Layout tab.

4. Select the Form Overlay check box, then click Overlay Settings. The Overlay Settings dialog box appears.

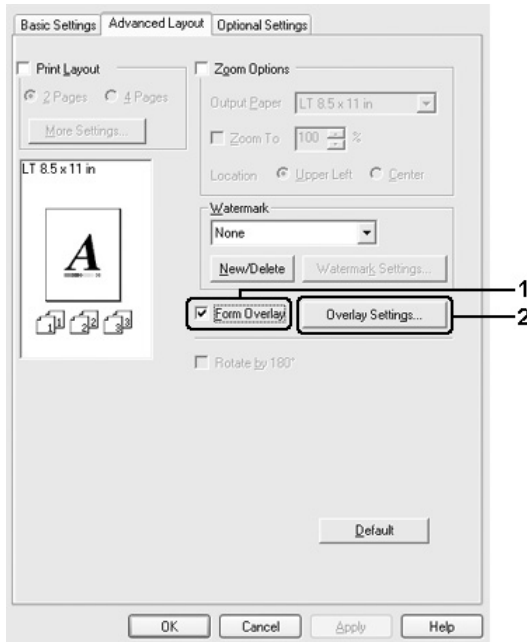

5. Select Create Overlay Data, then click Settings. The Form Settings dialog box appears.

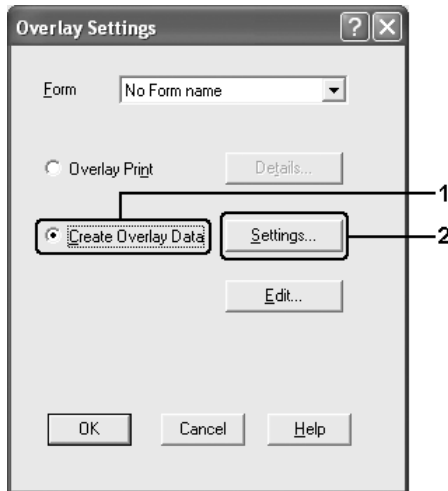

6. Select the Use Form Name check box, then click Add Form Name. The Add Form dialog box appears.

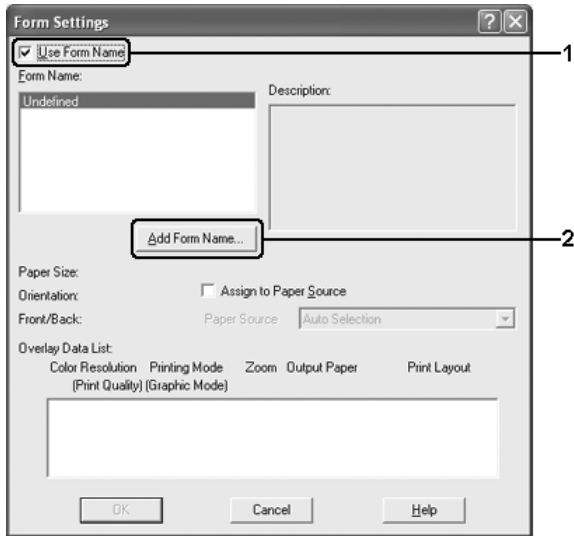

Note:

If the Assign to Paper Source check box is selected, the form name is displayed in the Paper Source drop-down list on the Basic Settings tab.

7. Type the form name in the Form Name box and its description in the Description box.

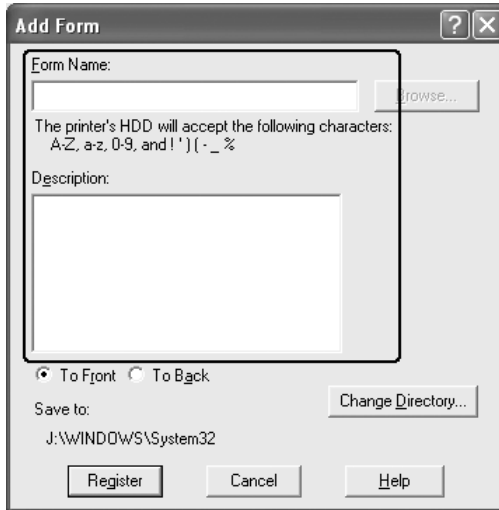

8. Select To Front or To Back to specify whether the overlay will be printed as background or foreground of the document.
9. Click Register to apply the settings and return to Form settings dialog box.
10. Click OK in the Form Settings dialog box.
11. Click OK in the Overlay Settings dialog box.
12. Print the file saved as overlay data. It is possible to save any kind of file as an overlay. The overlay data is created.

Printing with an overlay

Follow the steps below to print a document with overlay data.

1. Open the file to print with overlay data.

2. From the application, access the printer driver. Open the File menu, choose Print or Print Setup, then click Printer, Setup, Options, Properties, or a combination of these buttons, depending on your application.
3. Click the Advanced Layout tab.
4. Select the Form Overlay check box, and click Overlay Settings to open the Overlay Settings dialog box.
5. Choose the form from the Form drop-down list, then click OK to return the Advanced Layout tab.

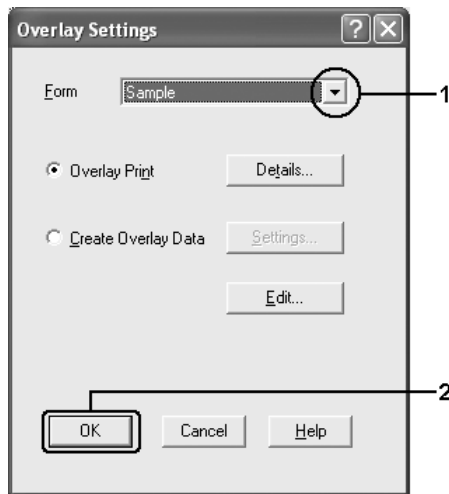

Note:

If the Assign to Paper Source check box is selected, the form name is displayed in the Paper Source drop-down list on the Basic Settings tab. You can also select the form without accessing the dialog box above.

6. Click OK to print the data.

Different printer settings overlay data

The overlay data is made with the current printer settings (such as Orientation: Portrait). If you want to make the same overlay with different printer settings (such as Landscape), follow the instructions below.

1. Re-access the printer driver as described in step 2 in "Creating an overlay" on page 76.
2. Make the printer settings and exit the printer driver.
3. Send the same data that you made by application to the printer like step 12 in "Creating an overlay" on page 76.

This setting is available only for Form Name data.

Making Extended Settings

You can make various settings in the Extended Settings dialog box. To open the dialog box, click Extended Settings on the Optional Settings tab.

Printing mode:	<p>High Quality (PC): Select this mode if you use a computer with higher specs to reduce the printer load. In this mode, functions such as "Form Overlay," and "Print true type with fonts with substitution" cannot be used.</p> <p>High Quality (Printer): Select this mode if you use a computer with lower specs to reduce the PC load.</p>
Print True Type fonts as bitmap radio button:	Select this check box to print, as bitmap, the True Type fonts that are not substituted with device fonts in the document.
Print True Type fonts with substitution radio button:	Select this check box to print the True Type fonts in the document as device fonts. This function is not available when the Printing Mode setting is set to High Quality (PC).
Setting button:	Click this button to open the Font Substitution dialog box. This button is available when Print True Type fonts with substitution is selected.
Uses the settings specified on the printer radio button:	Select this check box to use the Offset, the Skip blank page, and Ignore the selected paper size settings on the control panel.
Uses the settings specified on the driver radio button:	Select this check box to use the Offset, the Skip blank page, and Ignore the selected paper size settings in the printer driver.
Offset:	Makes fine adjustments to the printing position on the front and the back of data on a page in 0.5 mm increments.
Density:	Select a print density in the range 1 to 5. Adjust the print density to any of 5 levels to make your printout lighter or darker. 1 is the lightest, 5 is the darkest.

Skip Blank Page check box:	The printer will automatically remove any blank pages from the print job to save paper.
Ignore the selected paper size check box:	When you select this check box, the printer prints on loaded paper, regardless of size.
High Speed Graphics Output check box:	Select this check box to optimize the printing speed of graphics composed of line drawings such as overlaid circles and squares. Clear this check box if graphics do not print correctly.
Uses the collate settings specified in the application check box:	Select this check box to enable the collate settings that are specified on the application.
Uses the spooling method provided by the operating system check box:	Select this check box to enable the Spool function for Windows XP, 2000, or Server 2003.
Extended Printable Area check box ^{*1*2} :	Select this check box to extend printable area by decreasing the margins to 4 mm.
Default button:	Click this button to return the driver settings to the initial settings.
Help button:	Click this button to open online help.
Cancel button:	Click this button to exit the dialog box or printer driver without saving the settings.
OK button:	Click this button to save the settings and to exit the dialog box or printer driver.

^{*1} When Extended Printable Area check box is selected, there is 4-mm minimum margin on all sides.

^{*2} Extend Printable Area cannot be selected if you print on Wide A4 size paper.

Making Optional Settings

You can update the installed option information manually if you have installed options to your printer.

For Windows XP/2000:

1. Open the printer's Properties dialog box.
2. Click the Optional Settings tab, then select Update the Printer Option Info Manually.
3. Click Settings. The Optional Settings dialog box appears.
4. Make settings for each installed option, then click OK.

For Windows Me/98:

1. Click the Optional Settings tab, then select Update the Printer Option Info Manually.
2. Click Settings. The Optional Settings dialog box appears.
3. Make settings for each installed option, then click OK.

Printing a status sheet

To confirm the current status of the printer, print a status sheet from the printer driver. The status sheet contains information about the printer, the current settings.

Follow the steps below to print a status sheet.

1. Access the printer driver.
2. Click the Optional Settings tab and then click Status Sheet. The printer starts printing a status sheet.

Monitoring Your Printer Using EPSON Status Monitor

Installing EPSON Status Monitor

Follow the steps below to install EPSON Status Monitor.

1. Make sure that the printer is off and that Windows is running on your computer.
2. Insert the printer software CD-ROM in the CD-ROM drive.

Note:

- If the language selection window appears, select your country.*
 - If the Epson Installation Program screen does not appear automatically, double-click the My Computer icon, right-click the CD-ROM icon, click OPEN in the menu that appears, then double-click Epsetup.exe.*
3. Click User Installation.

4. Click Custom Install.



Note:

See the Network Guide for information on installing EPSON Status Monitor on a network.

5. Click EPSON Status Monitor.

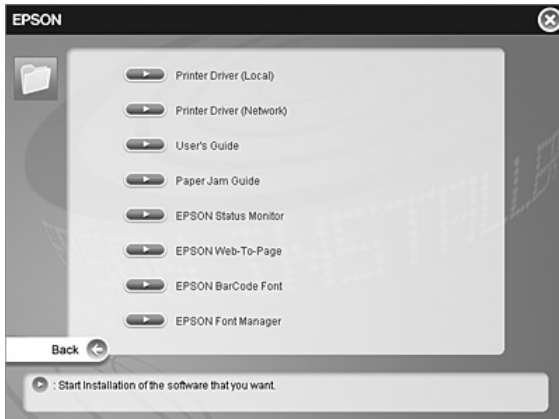

6. In the dialog box that appears, make sure that your printer's icon is selected, and click OK.

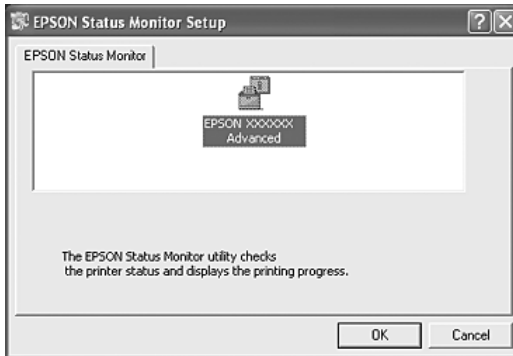

7. When the software license agreement screen appears, read the statement and then click Accept.



8. In the dialog box that appears, select your country or region, and the URL for EPSON's Web site in that country or region appears. Then click OK.



Note:

- ❑ *In the dialog box, you can set the URL for the site where you can order consumables online. See "Order Online" on page 100 for details.*
- ❑ *Selecting your country or region allows you to change the settings of the URL.*
- ❑ *When you click the Cancel button, the Web site's URL does not appear, but the EPSON Status Monitor installation continues.*

9. When the installation is complete, click OK.

Accessing EPSON Status Monitor

EPSON Status Monitor is a utility program that monitors your printer and gives you information about its current status. Follow the steps below to access EPSON Status Monitor.

1. Right-click the tray icon on the taskbar.
2. Select your printer name and then Simple Status. The Simple Status window appears.

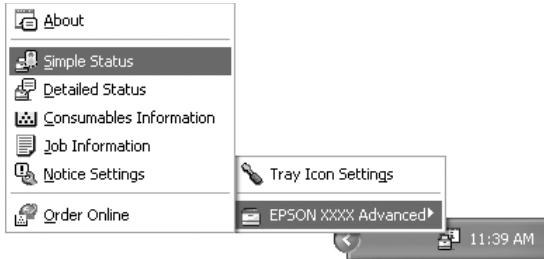

Note:

You can also access EPSON Status Monitor by clicking the Simple Status button on the Optional Settings tab.

To find detailed information on EPSON Status Monitor, see "Information on EPSON Status Monitor" on page 91, "Simple Status" on page 92, "Detailed Status" on page 93, "Consumables Information" on page 94, "Job Information" on page 96, "Notice Settings" on page 99, "Order Online" on page 100, and "Tray Icon Settings" on page 102.

Note for Windows XP users:

EPSON Status Monitor is not available when printing from a Remote Desktop connection.

Note for Netware users:

When monitoring NetWare printers, a Novell Client that corresponds to your operating system must be used. Operation is confirmed for the versions below:

- ❑ *For Windows 98:
Novell Client 3.4 for Windows 95/98*

- ❑ *For Windows XP or 2000:
Novell Client 4.91 SP1 for Windows 2000/XP*
- ❑ *To monitor a NetWare printer, connect only one print server to each queue. For directions, see the Network Guide for the printer.*
- ❑ *You cannot monitor a NetWare queue printer beyond the IPX router because the setting for IPX hops is 0.*
- ❑ *This product supports NetWare printers configured by a queue-based printing system such as Bindery or NDS. You cannot monitor NDPS (Novell Distributed Print Services) printers.*

Information on EPSON Status Monitor

You can obtain information about EPSON Status Monitor such as product versions or interface versions.



This window appears by right-clicking the tray icon on the taskbar and selecting your printer name and About.

Simple Status

The Simple Status window indicates printer status, errors, and warnings.

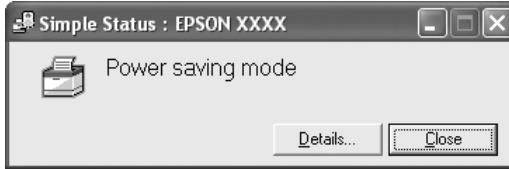

This window appears by right-clicking the tray icon on the taskbar, then selecting your printer name, then clicking Simple Status. This window also appears when errors occur according to the Pop-up Notice you select in the Notice Settings dialog box.

If you wish to see more information about the status of your printer, click Details.

Detailed Status

You can monitor detailed printer status by right-clicking the tray icon on the taskbar, then selecting your printer name, then clicking Detailed Status.

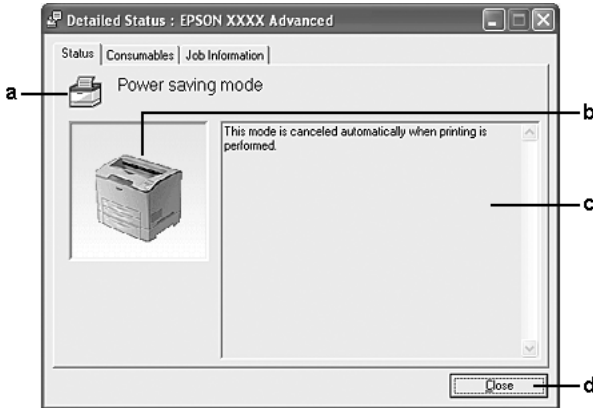

a.	Icon/Message:	The icon and message show the printer status.
b.	Printer image:	The image at the upper left shows the printer status graphically.
c.	Text box:	The text box next to the printer image displays the current status of the printer. When a problem occurs, the most probable solution is displayed.
d.	Close button:	Clicking this button closes the dialog box.

Note:

You can see information about jobs or consumables by clicking on the respective tab.

Consumables Information

You can obtain information on paper sources and consumable products by right-clicking the tray icon on the taskbar, then selecting your printer name, then clicking Consumables Information.

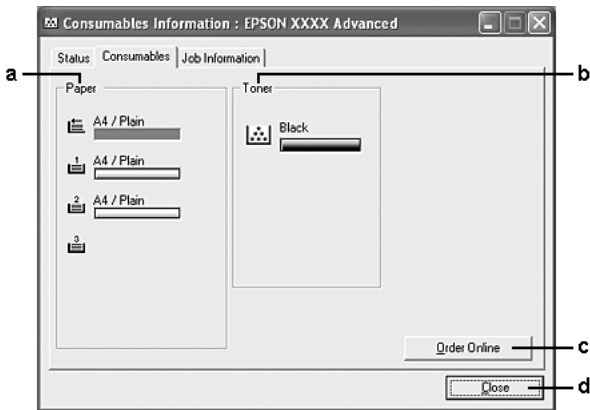

a.	Paper:	Displays the paper size, the paper type and the approximate amount of paper remaining in the paper source. Information on the optional paper cassettes are displayed only if these options are installed. The paper cassette icon flashes when the amount of paper remaining in the paper cassette is low.*
b.	Toner:	Indicates the amount of remaining toner. The toner icon flashes when a toner error occurs or the toner is low.
c.	Order Online button:	Clicking this button enables you to order consumables online. See "Order Online" on page 100 for details.
d.	Close button:	Clicking this button closes the dialog box.

* The icon flashes only for the optional 550-Sheet Universal Paper Cassette Unit.

Note:

You can see the status of the printer or information about jobs by clicking on the respective tab.

Job Information

You can check job information by right-clicking the tray icon on the taskbar, then selecting your printer name, then clicking Job Information.

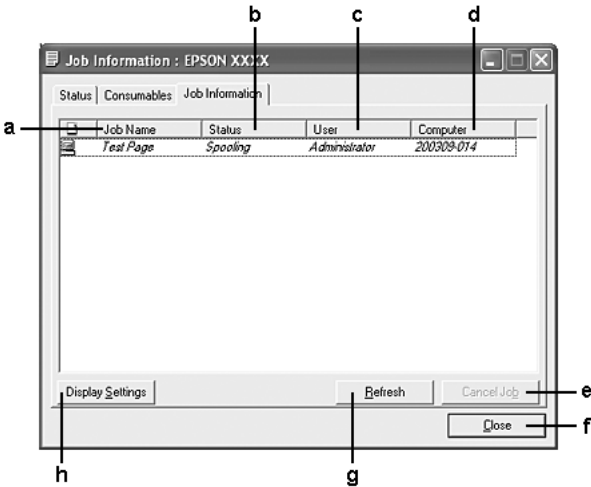

a.	Job Name:	Displays the user's print job names. Other user's print jobs are displayed as -----.	
b.	Status:	Waiting:	The print job which is waiting to be printed.
		Spooling:	The print job which is being spooled on your computer.
		Deleting:	The print job which is being deleted.
		Printing:	The print job which is printed currently.
		Completed:	Displays only your jobs that have finished printing.
	Canceled:	Displays only your jobs that have been canceled printing.	

c.	User:	Displays the user name.
d.	Computer:	Displays the name of the computer that sent the print job.
e.	Cancel Job button:	Selecting a print job and clicking this button cancels the selected print job.
f.	Close button:	Clicking this button closes the dialog box.
g.	Refresh button:	Clicking this button refreshes the information on this menu.
h.	Display settings button:	Displays the Display settings dialog box to select items to be displayed.

Note:

You can see the status of the printer or information about consumables by clicking on the respective tab.

Note for Windows XP users:

Shared Windows XP LPR connections and shared Windows XP Standard TCP/IP connections with Windows clients do not support the Job Management function.

The Job Information tab is available when the following connections are used:

Server and Client Environments:

- When using the shared Windows 2000 or Server 2003 LPR connection with Windows XP, Me, 98, or 2000 clients.
- When using the shared Windows 2000 or Server 2003 Standard TCP/IP connection with Windows XP, Me, 98, or 2000.
- When using the shared Windows 2000 or Server 2003 EpsonNet Print TCP/IP connection with Windows XP, Me, 98, 2000 clients.

Client only Environments:

- ❑ When using the LPR connection (in Windows XP, 2000, or Server 2003).
- ❑ When using the Standard TCP/IP connection (in Windows XP, 2000, or Server 2003).
- ❑ When using the EpsonNet Print TCP/IP connection (in Windows XP, Me, 98, 2000, or Server 2003).

Note:

You cannot use this function in the following situations:

- ❑ *When using an optional Ethernet interface card that does not support the Job Management function.*
- ❑ *When the NetWare connections do not support the Job Management function.*
- ❑ *When the printing jobs from NetWare and NetBEUI are displayed as "Unknown" on the Job Management menu.*
- ❑ *Note that if the user account used to log on to a client is different from the user account used to connect to the server, the Job Management function is not available.*

Note on deleting print jobs:

You cannot delete the print job spooling on client computers running Windows Me or 98 using EPSON Status Monitor when the following connections are used:

- ❑ *When using the shared Windows 2000 or Server 2003 LPR connection.*
- ❑ *When using the shared Windows 2000 or Server 2003 standard TCP/IP connection.*
- ❑ *When using the shared Windows 2000 or Server 2003 EpsonNet Print TCP/IP connection.*

Notice Settings

You can make specific monitoring settings by right-clicking the tray icon on the taskbar, then selecting your printer name, then clicking Notice Settings. The Notice Settings dialog box appears.

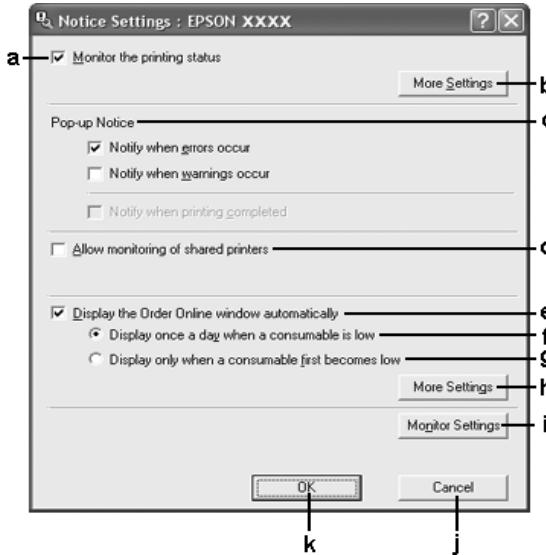

a.	Monitor the printer status check box:	When this check box is selected, EPSON Status Monitor monitors the printer status during a print job is processed.
b.	More Settings button:	Displays the More Settings dialog box to set how to display the tray icon.
c.	Pop-up Notice:	Sets the notification to be displayed.
d.	Allow monitoring of the shared printers check box:	When this check box is selected, a shared printer can be monitored by other computers.

e.	Display the Order Online window automatically check box:	When this check box is selected, the Order Online window appears automatically when a consumable becomes low or reaches end of service life and keeps appearing once a day until the consumable is replaced.
f.	Display once a day when a consumable is low check box:	When this radio button is selected, the Order Online window appears automatically once a day when you start printing or display the status by accessing EPSON Status Monitor.
g.	Display only when a consumable first becomes low check box:	When this radio box is selected, the Order Online window appears automatically only when a consumable first becomes low.
h.	More Settings button:	Displays the More Settings dialog box in which you can set the URL for placing an order appears.
i.	Monitor Settings button:	Displays the Monitor Settings dialog box to set the monitoring interval.
j.	Cancel button:	Click this button to exit the dialog box without saving the settings.
k.	OK button:	Click this button to save the settings and to exit the dialog box.

Order Online

You can order consumables online by clicking the Order Online button on the EPSON Status Monitor dialog box. The Order Online dialog box appears.

Note

The Order Online dialog box also appears by clicking the Order Online button on the Basic Settings tab in the printer driver.

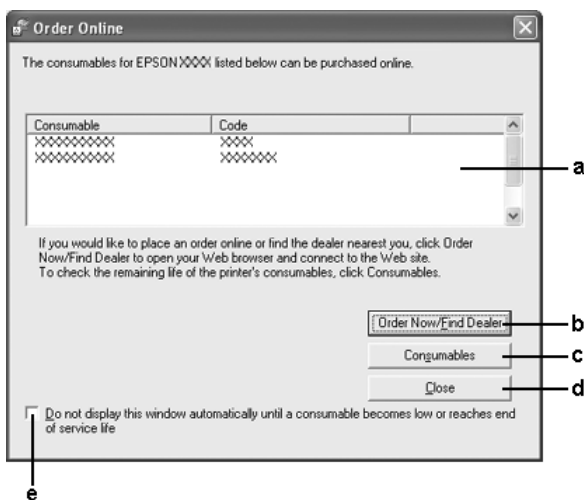

a.	Text box:	Displays the consumables and codes.
b.	Order Now/Find Dealer button:	Connects to the URL where you can place an order and find the dealer nearest you. When you click this button, a confirmation window asking if you wish to connect to the Web site appears. If you do not want this window to appear, select the Do not display the confirmation message before connecting check box in the More Settings dialog box. The More Settings dialog box appears by clicking the More Settings button in the Notice Settings dialog box.
c.	Consumables button:	Displays the consumables information.
d.	Close button:	Closes the dialog box.

e.	Do not display this window automatically until a consumable becomes low or reaches end of service life check box:	When this check box is selected, the Order Online window appears automatically only when a consumable first becomes low or reaches end of service life.
----	---	---

Tray Icon Settings

You can access EPSON Status Monitor by double-clicking the tray icon on the taskbar. The menu that appears by double-clicking the tray icon when no printing job is being processed depends on the settings you select. Follow the steps below to set the tray icon settings.

1. Right-click the tray icon on the taskbar, then select Tray Icon Settings.
2. Confirm that your printer is selected. Select the menu you wish to display from the Information to display drop-down list. Then click OK.

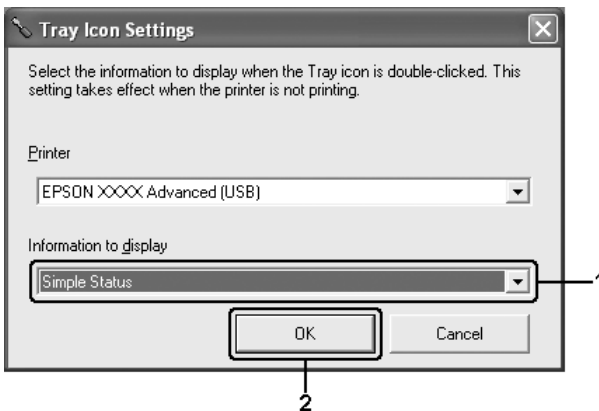

Note:

You can also access EPSON Status Monitor by right-clicking the tray icon and selecting your printer's name.

Setting Up the USB Connection

The USB interface that comes with your printer complies with Microsoft Plug and Play (PnP) USB specifications.

Note:

- ❑ *Only PC systems equipped with a USB connector and running Windows XP, Me, 98, 2000, or Server 2003 support the USB interface.*
 - ❑ *Your computer must support USB 2.0 in order to use USB 2.0 as the interface to connect your computer to the printer.*
 - ❑ *Since USB 2.0 is fully compatible with USB 1.1, USB 1.1 can be used as an interface.*
 - ❑ *USB 2.0 is applied for Windows XP, 2000, and Server 2003 operating systems. If your operating system is Windows Me or 98, use USB 1.1 interface.*
1. Access the printer driver.
 2. For Windows Me or 98, click the Details tab.
For Windows XP, 2000, or Server 2003, click the Ports tab.

- For Windows Me or 98, select the EPUSBX:(your printer name) USB port from the Print to the following port drop-down list.
For Windows XP, 2000, or Server 2003, select the USBXXX USB port in the list on the Ports tab.

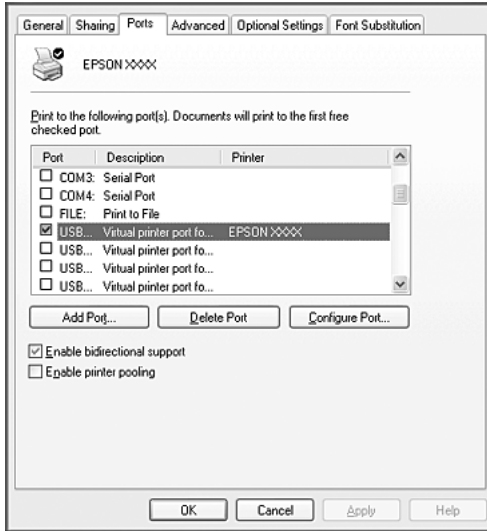

Note:

This screen may vary depending on your operating system version.

- Click OK to save the settings.

Canceling Printing

If the printouts are not what you expected and display incorrect or garbled characters or images, you may need to cancel printing. When the printer's icon is displayed on the taskbar, follow the instructions below to cancel the printing.

Double-click your printer's icon on the taskbar. Select the job in the list, then click **Cancel** from the Document menu.

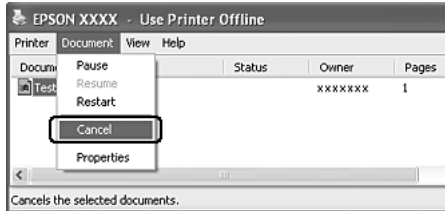

After the last page is output, the Ready (green) light on the printer turns on.

The current job is canceled.

Note:

You can also cancel the current print job that is sent from your computer, by pressing the  Cancel Job button on the printer's control panel. When canceling the print job, be careful not to cancel print jobs sent by other users.

Uninstalling the Printer Software

When you wish to reinstall or upgrade the printer driver, be sure to uninstall the current printer software beforehand.

Uninstalling the printer driver

1. Quit all applications.

2. Click Start, point to Settings, then click Control Panel.
For Windows XP or Server 2003, click Start, click Control Panel, then click Add or Remove Programs.
3. Double-click the Add/Remove Programs icon.
For Windows XP or Server 2003, click the Change or Remove Programs icon.



4. Select EPSON Printer Software, then click Add/Remove.
For Windows XP, 2000, or Server 2003, select EPSON Printer Software, then click Change/Remove.

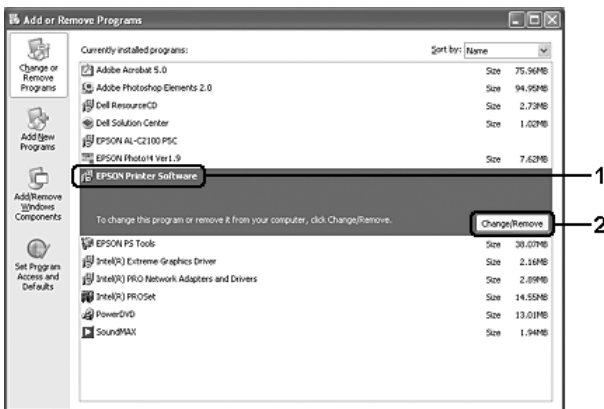

5. Click the Printer Model tab, select your printer's icon.

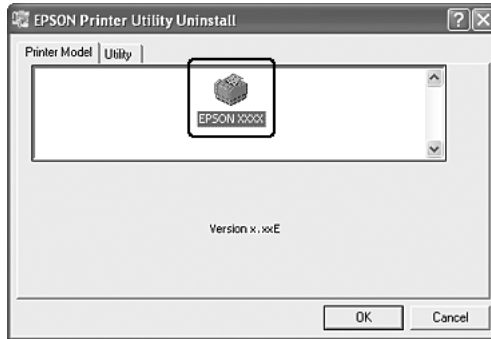

6. Click the Utility tab, and confirm that the check box for the printer software you want to uninstall is selected.

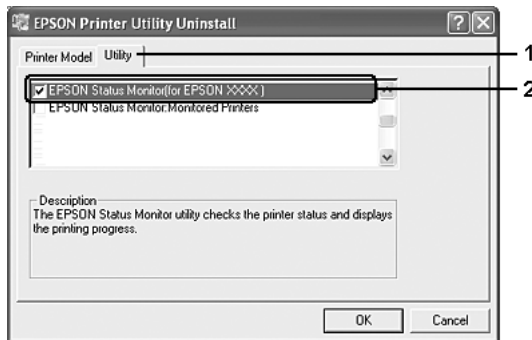

Note:

If you wish to uninstall only EPSON Status Monitor, select the EPSON Status Monitor check box.

7. To uninstall, click OK.

Note:

You can uninstall only the Monitored Printers utility of EPSON Status Monitor. When the utility is uninstalled, you cannot change the settings of Monitored Printers from EPSON Status Monitor of other printers.

8. Follow the on-screen instructions.

Uninstall the USB device driver

When you connect the printer to your computer with a USB interface cable, the USB device driver is also installed. When you uninstalled the printer driver, you also need to uninstall the USB device driver.

Follow the steps below to uninstall the USB device driver.

Note:

- Uninstall the printer driver before uninstalling the USB device driver.*
 - Once you uninstalled the USB device driver, you cannot access any other Epson printers connected with a USB interface cable.*
1. Follow steps 1 through 3 of "Uninstalling the printer driver" on page 105.

2. Select EPSON USB Printer Devices, then click Add/Remove.

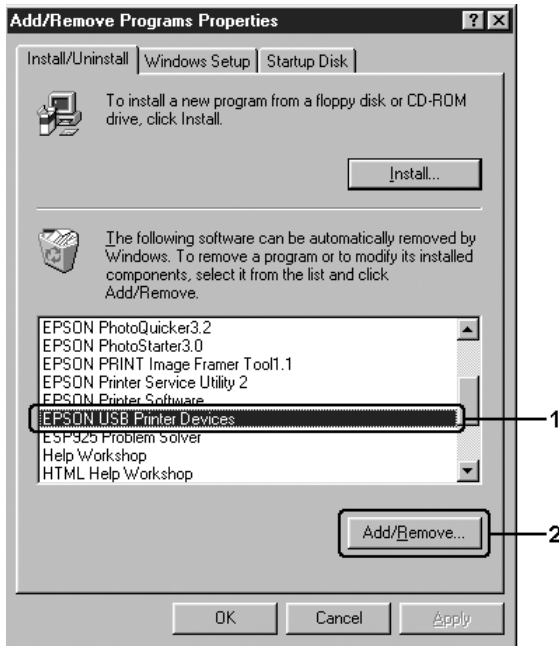

Note:

- ❑ EPSON USB Printer Devices *appears only when the printer is connected to Windows Me or 98 with a USB interface cable.*
- ❑ *If the USB device driver is not installed correctly, EPSON USB Printer Devices may not appear. Follow the steps below to run the "Epusun.exe" file in the CD-ROM that comes with your printer.*
 1. *Insert the CD-ROM in your computer's CD-ROM drive.*
 2. *Access the CD-ROM drive.*
 3. *Double-click your language folder.*
 4. *Double-click the Win9x folder.*
 5. *Double-click the Epusun.exe icon.*

3. Follow the on-screen instructions.

Sharing the Printer on a Network

Sharing the printer

This section describes how to share the printer on a standard Windows network.

The computers on a network can share a printer that is directly connected to one of them. The computer that is directly connected to the printer is the print server, and the other computers are the clients which need permission to share the printer with the print server. The clients share the printer via the print server.

According to the versions of Windows OS and your access rights on the network, perform the appropriate settings of the print server and clients.

Setting the print server

- ❑ For Windows Me or 98, see "Setting up your printer as a shared printer" on page 111.
- ❑ For Windows XP, 2000, or Server 2003, see "Using an additional driver" on page 112.

Setting the clients

- ❑ For Windows Me or 98, see "With Windows Me or 98" on page 119.
- ❑ For Windows XP or 2000, see "With Windows XP or 2000" on page 120.

Note:

- ❑ *When sharing the printer, be sure to set EPSON Status Monitor so that the shared printer can be monitored on the print server. See "Notice Settings" on page 99.*

- ❑ *When you are using shared printer in a Windows Me or 98 environment, on the server, double-click the Network icon in Control panel and make sure that the “File and printer sharing for Microsoft Networks” component is installed, then on the server and clients, make sure that the “IPX/SPX-compatible Protocol” or the “TCP/IP Protocol” is installed.*
- ❑ *The print server and clients should be set on the same network system, and they should be under the same network management beforehand.*

Setting up your printer as a shared printer

When the print server’s OS is Windows Me or 98 follow the steps below to set the print server.

1. Click Start, point to Settings, then click Control Panel.
2. Double-click the Network icon.
3. Click File and Print Sharing on the Configuration menu.
4. Select the I want to be able to allow others to print to my printer(s). check box, then click OK.
5. Click OK to apply the settings.

Note:

- ❑ *When “Insert the Disk” appears, insert the Windows Me or 98 CD-ROM in the computer. Click OK, then follow the on-screen instructions.*
 - ❑ *When the prompt to restart the computer appears, restart the computer, then continue with the settings.*
6. Double-click the Printers icon on the control panel.

7. Right-click your printer's icon, then click Sharing in the menu that appears.
8. Select Shared As, type the name in the Share Name box, then click OK. Type a Comment and Password if needed.

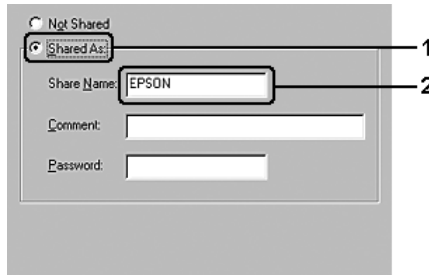

Note:

- ❑ Do not use spaces or hyphens for the share name, or an error may occur.
- ❑ When sharing the printer, be sure to set EPSON Status Monitor so that the shared printer can be monitored on the print server. See "Notice Settings" on page 99.

You need to set the client computers so that they can use the printer on a network. See the following pages for details:

- ❑ "With Windows Me or 98" on page 119
- ❑ "With Windows XP or 2000" on page 120

Using an additional driver

When the print server's OS is Windows XP, 2000, or Server 2003, you can install the additional drivers on the server. The additional drivers are for client computers that have different OS from the server.

Follow the steps below to set a Windows XP, 2000, or Server 2003 as a print server, then install the additional drivers.

Note:

You must access Windows XP, 2000, or Server 2003 as the Administrators of the local machine.

1. For a Windows 2000 print server, click Start, point to Settings, then click Printers.
For a Windows XP or Server 2003 print server, click Start, point to Printers and Faxes.
2. Right-click your printer's icon, then click Sharing in the menu that appears.

For Windows XP or Server 2003, if the following menu appears, click either Network Setup Wizard or if you understand the security risks but want to share printers without running the wizard, click here.

In either case, follow the on-screen instructions.



3. For a Windows 2000 print server, select Shared as, then type the name in the Share Name box.



For a Windows XP or Server 2003 print server, select Share this printer, then type the name in the Share name box.

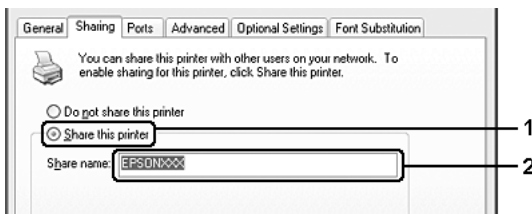

Note:

Do not use spaces or hyphens for the Share name, or an error may occur.

4. Select the additional drivers.

Note:

If the computers of the server and clients use the same OS, you do not have to install the additional drivers. Just click OK after step 3.

On the Windows XP, 2000, or Server 2003 print server

Click Additional Drivers.

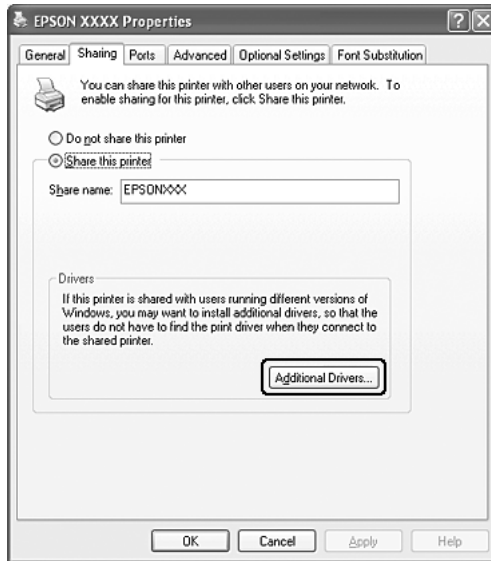

Select Windows being used for clients, then click OK.

For Windows Me or 98 clients	Intel Windows 95 or 98 (Windows 2000), Intel Windows 95, 98 and Me (Windows XP), x86 Windows 95, Windows 98 and Windows Millennium Edition (Windows Server 2003)
For Windows XP or 2000 clients	Intel Windows 2000 (Windows 2000), Intel Windows 2000 or XP (Windows XP), x86 Windows 2000, Windows XP and Windows Server 2003 (Windows Server 2003)



Note:

- You do not have to install the additional drivers noted below, because these drivers are preinstalled.*
Intel Windows 2000 (for Windows 2000)
Intel Windows 2000 or XP (for Windows XP)
x86 Windows 2000, Windows XP and Windows Server 2003 (for Windows Server 2003)

- ❑ *Do not select additional drivers other than the drivers listed in the above table. The other additional drivers are not available.*
5. When a prompt appears, insert the CD-ROM that comes with your printer in your CD-ROM drive, then click OK.
 6. According to the message, type the appropriate drive and folder names in which the printer driver for clients is located, then click OK.
Depending on the client's OS, the displayed message may differ.

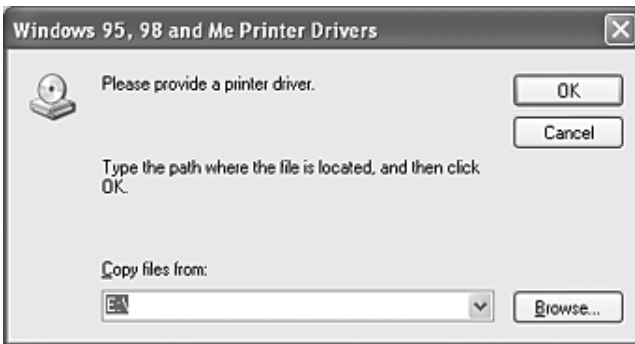

The folder name differs depending on the OS being used.

Client's OS	Folder Name
Windows Me or 98	\<Language>\WIN9X

When installing drivers in Windows XP, 2000, or Server 2003, "Digital Signature is not found." may appear. Click Yes (for Windows 2000) or Continue Anyway (for Windows XP or Server 2003) and continue installing.

7. Click Close.

Note:

Confirm the following items when sharing the printer:

- ❑ *Be sure to set EPSON Status Monitor so that the shared printer can be monitored on the print server. See "Notice Settings" on page 99.*
- ❑ *Set the security for the shared printer (access right for clients). Clients cannot use the shared printer without right. For details, see Windows help.*

You need to set the client computers so that they can use the printer on a network. See the following pages for details:

- ❑ "With Windows Me or 98" on page 119
- ❑ "With Windows XP or 2000" on page 120

Setting up clients

This section describes how to install the printer driver by accessing the shared printer on a network.

Note:

- ❑ *To share the printer on a Windows network, you need to set the print server. For details, see "Setting up your printer as a shared printer" on page 111 (Windows Me or 98) or "Using an additional driver" on page 112 (Windows XP, 2000, or Server 2003).*
- ❑ *This section describes how to access the shared printer on a standard network system using the server (Microsoft workgroup). If you cannot access the shared printer due to the network system, ask the administrator of the network for assistance.*
- ❑ *This section describes how to install the printer driver by accessing the shared printer from the Printers folder. You can also access the shared printer from Network Neighborhood or My Network on the Windows desktop.*
- ❑ *You cannot use the additional driver on the server system OS.*

- ❑ *When you want to use EPSON Status Monitor at clients, you have to install both of the printer driver and EPSON Status Monitor in each client from the CD-ROM.*

With Windows Me or 98

Follow the steps below to set Windows Me or 98 clients.

1. Click Start, point to Settings, then click Printers.
2. Double-click the Add Printer icon, then click Next.
3. Select Network printer, then click Next.
4. Click Browse, and the Browse for Printer dialog box appears.

Note:

You can also type "\\(the name of the computer that is locally connected to the shared printer)\(the shared printer's name)" in the network path or queue name.

5. Click the computer or server that is connected to the shared printer, and the name of the shared printer, then click OK.



Note:

The name of the shared printer may be changed by the computer or server that is connected to the shared printer. To make sure of the name of the shared printer, ask the administrator of the network.

6. Click Next.

Note:

- ❑ *If the printer driver is installed in the client beforehand, you need to select the new printer driver or the current printer driver. When the prompt to select the printer driver appears, select the printer driver according to the message.*
- ❑ *If the print server's OS is Windows Me or 98 or the additional driver for Windows Me or 98 is installed in the Windows XP, 2000, or Server 2003 print server, go to the next step.*
- ❑ *If the additional driver for Windows Me or 98 is not installed in the Windows XP, 2000, or Server 2003 print server, go to "Installing the printer driver from the CD-ROM" on page 125.*

7. Make sure of the name of the shared printer, then select whether to use the printer as the default printer or not. Click Next, then follow the on-screen instructions.

Note:

You can change the shared printer's name so that it appears only on the client computer.

With Windows XP or 2000

Follow the steps below to set Windows XP or 2000 clients.

You can install the printer driver for the shared printer, if you have Power Users or more powerful access rights even if you are not the Administrator.

1. For Windows 2000 clients, click Start, point to Settings, and click Printers.
For Windows XP clients, click Start, point to Printers and Faxes.
2. For Windows 2000, double-click the Add Printer icon, then click Next.
For Windows XP, click Add a printer in the Printer Tasks menu.

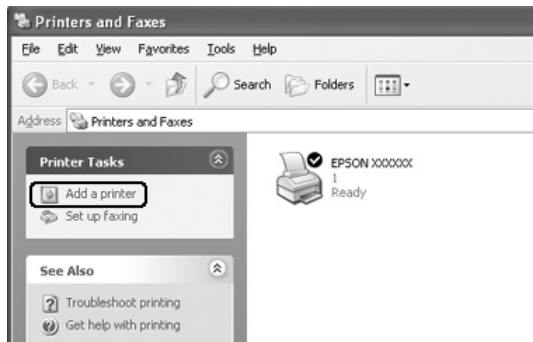

3. For Windows 2000, select Network printer, then click Next.
For Windows XP, select A network printer, or a printer attached to another computer, then click Next.

4. For Windows 2000, type the name of the shared printer, then click Next.

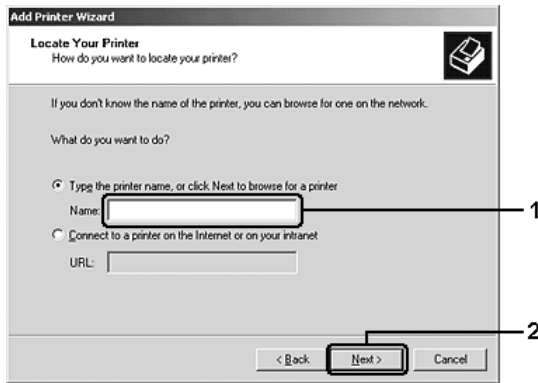

Note:

- ❑ You can also type "\\(the name of the computer that is locally connected to the shared printer)\(the shared printer's name)" in network path or queue name.
- ❑ You do not necessarily need to type the name of the shared printer.

For Windows XP, select Browse for a printer.

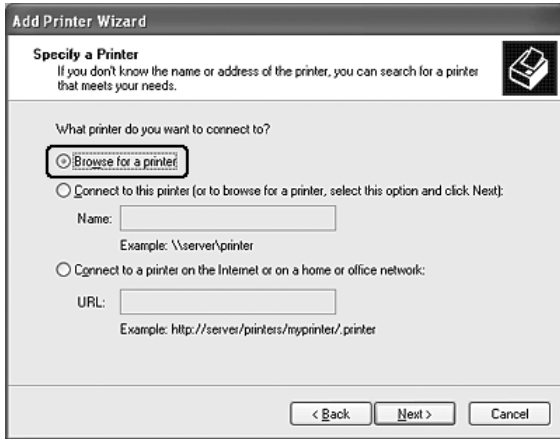

5. Click the icon of the computer or server that is connected to the shared printer, and the name of the shared printer, then click Next.

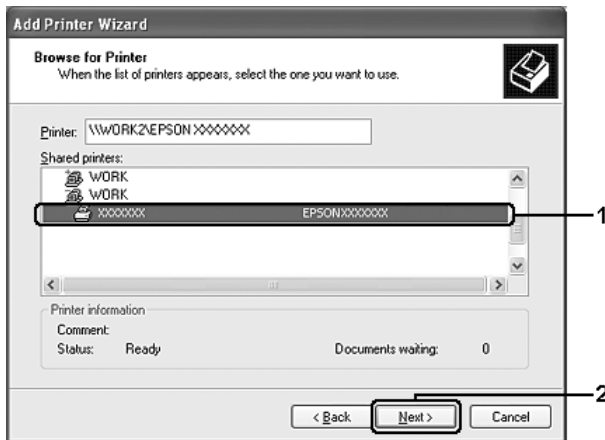

Note:

- ❑ *The name of the shared printer may be changed by the computer or server that is connected to the shared printer. To make sure of the name of the shared printer, ask the administrator of the network.*
 - ❑ *If the printer driver is installed in the client beforehand, you need to select either the new printer driver or the current printer driver. When the prompt to select the printer driver appears, select the printer driver according to the message.*
 - ❑ *If the additional driver for Windows XP or 2000 is installed in the Windows XP, 2000, or Server 2003 print server, go to the next step.*
 - ❑ *If the print server's OS is Windows Me or 98, go to "Installing the printer driver from the CD-ROM" on page 125.*
6. For Windows 2000, select whether to use the printer as the default printer or not, then click Next.
 7. Make sure of the settings, then click Finish.



Installing the printer driver from the CD-ROM

This section describes how to install the printer driver in the clients when setting the network system as follows:

- ❑ The additional drivers are not installed in the Windows XP, 2000, or Server 2003 print server.
- ❑ The print server's OS is Windows Me or 98 and the client's OS is Windows XP or 2000.

The on-screen displays on the following pages may differ depending on the version of Windows OS.

Note:

- ❑ *When installing in Windows XP or 2000, clients, you must access Windows XP or 2000 as the Administrator.*
 - ❑ *If the additional drivers are installed or the computers of the server and clients use the same OS, you do not have to install the printer drivers from the CD-ROM.*
1. Access the shared printer and a prompt may appear. Click OK, then follow the on-screen instructions to install the printer driver from the CD-ROM.
 2. Insert the CD-ROM, type the appropriate drive and folder names in which the printer driver for clients is located, then click OK.



When installing drivers in Windows XP, 2000, or Server 2003, “Digital Signature is not found.” may appear. Click Yes (for Windows 2000) or Continue Anyway (for Windows XP or Server 2003) and continue installing.

The folder name differs depending on the OS being used.

Client's OS	Folder Name
Windows Me or 98	\\<Language>\WIN9X
Windows 2000 or XP	\\<Language>\WINXP_2K

3. Select the name of the printer, click OK, then follow the on-screen instructions.

Using the PostScript Printer Driver

About the PostScript 3 Mode

System requirements

Your computer must meet the following system requirements to be able to use the Adobe PostScript 3 printer driver.

For Windows

To use the Adobe PostScript 3 printer driver, your computer must be running Microsoft Windows XP, Me, 98 or 2000. See the following table for details.

Windows XP or 2000

There are no restrictions for these systems.

Windows Me or 98

	Minimum	Recommended
Computer	i386, i486, or Pentium processor	i486 or Pentium processor
Hard Disk	6 MB free (for driver installation)	6 MB free (for driver installation)
Memory	8 MB	32 MB

For Macintosh

Any Macintosh computer to which the printer is connected must be running Mac OS 9 ver. 9.1 or later, or Mac OS X ver. 10.2.x or later. See the following table for details.

Mac OS X

There are no restrictions for this system.

Note:

To use binary data, Epson recommends that you use AppleTalk for the printer's network connection. If you use a protocol other than AppleTalk for the network connection, you need to set Binary to On in the PS3 Menu on the control panel. If you use the printer with a local connection, you cannot use binary data.

Mac OS 9

	Minimum	Recommended
Computer	Power PC	
Hard Disk	3.1 MB free (for driver installation)	4 MB free (for driver installation)
Memory	4 MB	32 MB

Note:

To use binary data, Epson recommends that you use AppleTalk for the printer's network connection. If you use a local connection or a protocol other than AppleTalk for the network connection, you cannot use binary data.



Caution:

- The Adobe PostScript 3 printer driver cannot be used on computers running System 9.0.x or below.*

- The Adobe PostScript 3 printer driver cannot be used on Macintosh 68K computers.*

Note:

For best results, you should connect the printer directly to the computer's USB port. If multiple USB hubs must be used, we recommend that you connect the printer to the first-tier hub.

Using the PostScript Printer Driver with Windows

To print in the PostScript mode, you will have to install the printer driver. See the appropriate sections below for installation instructions according to the interface that you are using to print.

Installing the PostScript printer driver for the parallel interface

Follow the steps below to install the PostScript printer driver for the parallel interface.



Caution:

Never use EPSON Status Monitor when the printer is connected via a parallel port. It may damage the system.

Note:

- Installing the printer software for Windows XP or 2000 may require administrator privileges. If you have problems, ask your administrator for more information.*
 - Turn off all virus protection programs before installing the printer software.*
1. Make sure that the printer is turned off. Insert the printer software CD-ROM into your CD-ROM drive.

2. For Windows 2000, Me, or 98, click Start, point to Settings, and click Printers. Then double-click the Add Printer icon. For Windows XP, click Start, point to Printer and Faxes, and click Add a printer in the Printer Tasks menu.
3. The Add Printer Wizard appears. Then click Next.
4. For Windows Me or 98, go to step 6. For Windows XP or 2000, select Local printer, then click Next.

Note:

For Windows XP or 2000, do not select the Automatically detect and install my Plug and Play printer check box.

5. Select LPT1 as the port the printer is connected to, then click Next.
6. Click Have Disk and specify the following path for the CD-ROM. If your CD-ROM drive is D:, the path will be D:\ADOBEPS\ENGLISH\Folder Name\PS_SETUP. Then click OK.

Note:

- Change the drive letter as needed for your system.*
- The folder name differs depending on your operating system version.*

Operating system version	Folder Name
Windows Me or 98	WIN9X
Windows XP or 2000	WIN2K_XP

7. Select the printer, then click Next.
8. For Windows Me or 98, select LPT1 as the port the printer is connected to, then click Next. For Windows XP or 2000, go to the next step.

9. Follow the on-screen instructions for the rest of the installation.
10. When installation is done, click Finish.

Installing the PostScript printer driver for the USB interface

Follow the steps below to install the PostScript printer driver for the USB interface.



Caution:

Never use EPSON Status Monitor when the printer is connected via a USB port. It may damage the system.

Note:

- ❑ *For Windows Me or 98, if the Windows driver and the Adobe PS driver for Epson printers with a USB connection have already been installed on your computer, follow the installation procedure "Installing the PostScript printer driver for the parallel interface" on page 129, but make sure to select USB as the port in step 5. If you have not installed an Epson USB printer driver on your computer, follow the installation procedure below.*
 - ❑ *Installing the printer software for Windows XP or 2000 may require administrator privileges. If you have problems, ask your administrator for more information.*
 - ❑ *Turn off all virus protection programs before installing the printer software.*
1. Make sure that the printer is turned off. Insert the printer software CD-ROM into your CD-ROM drive.
 2. Connect your computer to the printer with a USB cable, then turn on the printer.
 3. Install the USB Device Driver.

For Windows Me, select Automatic search for a better driver (Recommended), click Next, then go to step 6.

For Windows 98, click Next in the Add New Hardware Wizard. Select Search for best driver for your device (Recommended), then click Next.

Note:

For Windows XP or 2000, a USB Device Driver is installed automatically. Go to step 7.

4. Select Specify a location, then specify the following path for the CD-ROM. If your CD-ROM drive is D:, the path will be D:\ADOBEPS\ENGLISH\WIN9X\PS_SETUP Then click Next.

Note:

Change the drive letter as needed for your system.

Operating system version	Folder Name
Windows Me or 98	WIN9X
Windows XP or 2000	WIN2K_XP

5. Click Next to continue.
6. When installation of the USB Device Driver is done, click Finish.
7. Install the printer driver by following the on-screen instructions. See "Installing the PostScript printer driver for the parallel interface" on page 129 for details.

Installing the PostScript printer driver for the network interface

See the appropriate sections below according to your operating system, and follow the instructions to install the PostScript printer driver for the network interface.

Note:

- Set the network settings before installing the printer driver. Refer to the Network Guide that comes with your printer for details.*
- Turn off all virus protection programs before installing the printer software.*

For Windows XP or 2000 users

1. Make sure that the printer is turned on. Insert the printer software CD-ROM into your CD-ROM drive.
2. For Windows XP, click Start, point to Printer and Faxes, and click Add a printer in the Printer Tasks menu. For Windows 2000, click Start, point to Settings, and click Printers. Then double-click the Add Printer icon.
3. The Add Printer Wizard appears. Then click Next.
4. Select Local printer, then click Next.

Note:

Do not select the Automatically detect and install my Plug and Play printer check box.

5. Select the Create a new port check box and select Standard TCP/IP Port from the drop-down list. Click Next.
6. Click Next to continue.
7. Specify the IP address and port name, then click Next.

8. Click Finish.
9. Click Have Disk in the Add Printer Wizard and specify the following path for the CD-ROM. If your CD-ROM drive is D:, the path will be D:\ADOBEPS\ENGLISH\WIN2K_XP\PS_SETUP. Then click OK.

Note:

Change the drive letter as needed for your system.

10. Select the printer and click Next.
11. Follow the on-screen instructions for the rest of the installation.
12. When installation is done, click Finish.

For Windows Me or 98 users

1. Install the EpsonNet Print. Refer to "Installing EpsonNet Print" in the *Network Guide* to find the instructions.
2. Install the printer driver. See "Installing the PostScript printer driver for the parallel interface" on page 129 for details.
3. Set the printer port to EpsonNet Print Port. Refer to "Configuring the Printer Port" in the *Network Guide* to find the instructions.

Note:

High-speed Printing (RAW) is not supported.

Accessing the PostScript printer driver

You can access the PostScript printer driver directly from any application programs, from your Windows operating system.

The printer settings made from many Windows applications override the setting made when the printer driver is accessed from the operating system, so you should access the printer driver from your application to make sure that you get the result you want.

From the application

To access the printer driver, click the Print or Page Setup from the File menu. You also need to click Setup, Options, Properties, or a combination of these buttons.

For Windows XP users

To access the printer driver, click Start, click Printers and Faxes, then click Printers. Right-click your printer icon, then click Printing Preferences.

For Windows Me or 98 users

To access the printer driver, click Start, point to Settings, then click Printers. Right-click your printer icon, then click Properties.

For Windows 2000 users

To access the printer driver, click Start, point to Settings, then click Printers. Right-click your printer icon, then click Printing Preferences.

Making changes to PostScript printer settings

You can change the PostScript printer settings in the PostScript printer driver. Online help is available to help you with the printer driver settings.

Using online help

If you want help on a particular item, click the “?” icon on the top-right corner of the dialog box’s title bar, then click the name of the setting that you want more information on. An explanation of the setting and its options will be displayed.

Notice for Windows Me or 98 Users

The printer may not print normally if the computer is connected to the printer via the parallel interface and the ECP mode is set. If this is the case, disable bi-directional support in the printer driver. To do so, display the printer’s Properties dialog box, click the Details tab, then click Spool Settings. In the Spool Settings dialog box that appears, Select Disable bi-directional support for this printer, then click OK.

Using AppleTalk under Windows 2000

Use the following settings if your machine is running Windows 2000, and the printer is connected through an network interface using the AppleTalk protocol:

- Use SelecType to set the Emulation Mode-Network item to PS3. Using the default Auto setting will cause an extra, unneeded page to be printed.
- On the Device Settings sheet of the printer’s Properties dialog box, make sure that SEND CTRL-D Before Each Job and SEND CTRL-D After Each Job are set to No.
- TBCP (Tagged binary communications protocol) cannot be used as the Output Protocol setting.
- On the Job Settings sheet of the printer’s Properties dialog box, make sure to clear the Job Management On check box.

Using the PostScript Printer Driver with Macintosh

Installing the PostScript printer driver

Follow the steps below to install the PostScript printer driver.

Note:

Make sure that no applications are running on your Macintosh before installing the printer driver.

For Mac OS X users

Note:

Make sure that Printer Setup Utility (for Mac OS X 10.3) or Print Center (for Mac OS X 10.2) is not open.

1. Insert the printer software CD-ROM into your CD-ROM drive.
2. Double-click the CD-ROM icon.
3. Double-click Adobe PS, then double-click Mac OS X.
4. Double-click PS Installer.

Note:

For Mac OS X 10.2, if the Authenticate window appears, enter the user name and password for an administrator.

5. The Install EPSON PostScript Software screen appears, click Continue, then follow the on-screen instructions.
6. Easy Install is displayed on the screen. Click Install.

Note:

For Mac OS X 10.3, if the Authenticate window appears, enter the user name and password for an administrator.

7. When installation is done, click Close.

For Mac OS 9 users

1. Insert the printer software CD-ROM into your CD-ROM drive.
2. Double-click the CD-ROM icon.
3. Double-click Adobe PS, then double-click Mac OS 9.
4. Double-click English, then double-click AdobePS 8.7.
5. Double-click AdobePS Installer. Then follow the on-screen instructions.
6. Select Easy Install, then click Install.
7. When installation is done, click Quit.

Note:

If you are connecting two or more EPSON printers of the same model using AppleTalk, and you want to rename the printer, see the Network Guide.

Selecting the printer

After installing the PostScript 3 printer driver, you need to select the printer.

Selecting the printer when it is connected via a USB connection for Mac OS 9 users

If the printer is connected to your computer via a USB port, you will not be able to select the printer from the Chooser. You will have to launch the Apple Desktop Printer Utility, then register the printer as a Desktop Printer. The Desktop Printer Utility is automatically installed when you install the Adobe PostScript printer driver. Follow the steps below to select the printer and to create a Desktop Printer.

Note:

When printing via the USB port from a Power Macintosh running Mac OS 9, the printer must be set to handle ASCII data. To specify this setting, select Print from the File menu of the application that you are using, then select the name of the application from the options available in the Print dialog box. On the setup option page that appears, select ASCII for the data format setting. The actual setting name varies by application, but is often called Encoding or Data.

1. Open the AdobePS Components folder in your hard disk, then double-click the Desktop Printer Utility.
2. The New Desktop Printer dialog box appears. Select AdobePS from the With pop-up menu, click Printer (USB) in the Create Desktop list, then click OK.
3. Click Change in USB Printer Selection.
4. The USB Printer dialog box appears. Select your printer from the list of connected USB printers, then click OK.
5. Click Auto Setup to select the PostScript Printer Description (PPD) file. When a PPD file is selected, the selected printer name will be displayed under the printer icon. If the printer name is incorrect, click Change, then select the correct PPD file.

6. After the USB printer and PPD file have been selected, click **Create**. A warning message suggesting to save changes to desktop printer appears. Select **Save**.
7. Select **Save** to continue. The USB printer icon will be displayed on the desktop.

Selecting a printer in a network environment

If the printer is connected through the Ethernet interface or an optional network card.

For Mac OS X users

Follow the steps below to select the printer.

Note:

- You cannot use FireWire for printer connection in the PostScript 3 mode. Although EPSON FireWire appears in the interface pop-up list, it cannot be used with the PostScript 3 printer driver.*
 - You need to make the settings for your installed options manually when the printer is connected using USB, IP printing, or Rendezvous. When the printer is connected using AppleTalk, the printer software automatically makes the settings.*
 - Make sure to specify ASCII as the data format in the application.*
1. Open the Applications folder, open the Utilities folder, then double-click Printer Setup Utility (for Mac OS X 10.3) or Print Center (for Mac OS X 10.2).
The Printer List window appears.
 2. Click **Add** in the Printer List window.
 3. Select the protocol or the interface that you are using from the pop-up list.

Note for Appletalk users:

Make sure to select AppleTalk. Do not select EPSON AppleTalk, because it cannot be used with the PostScript 3 printer driver.

Note for IP Printing users:

- Make sure to select IP Printing. Do not select EPSON TCP/IP, because it cannot be used with the PostScript 3 printer driver.

- After selecting IP Printing, enter the IP address for the printer, then make sure to select the Use default queue on server check box.

Note for USB users:

Make sure to select USB. Do not select EPSON USB, because it cannot be used with the PostScript 3 printer driver.

4. Follow the instructions as appropriate below to select your printer.

AppleTalk

Select your printer from the Name List, then select Auto Select from the Printer Model List.

IP Printing

Select Epson from the Name List, then select your printer from the Printer Model List.

USB

Select your printer from the Name List, then select your printer from the Printer Model List.

Note for Mac OS X 10.3 users

If ESC/Page driver is not installed, your printer model is automatically selected in the Printer Model List when you select your printer from the Name List while the printer is on.

Rendezvous

Select your printer, the printer name is followed by (PostScript), from the Name List. Your printer model is automatically selected in the Printer Model List.

Note for USB (for Mac OS X 10.2) or Rendezvous users:
If your printer model is not automatically selected in the Printer Model list, you need to reinstall the PostScript printer driver. See "Installing the PostScript printer driver" on page 137.

5. Click Add.

Note for IP Printing users, USB or Rendezvous users:
Select your printer from the Printer list, then select Show Info from the Printers menu. The Printer Info dialog box appears. Select Installable Options from the pop-up list, then make the necessary settings.

6. Confirm that your printer's name is added to the Printer List. Then quit Printer Setup Utility (for Mac OS X 10.3) or Print Center (for Mac OS X 10.2).

For Mac OS 9 users

Follow the steps below to select the printer.

1. Select Chooser from the Apple menu.
2. Make sure that AppleTalk is active.
3. Click the AdobePS icon and select the network to be used in the AppleTalk Zone box. Your printer appears in the Select a PostScript Printer box.

Note:

By default, the six-digit MAC address is displayed after the printer name if the printer is connected through an optional network card. Refer to your network card manual for details.

4. Click your printer. The Create button appears.

Note:

If your computer is connected to more than one AppleTalk zone, click the AppleTalk zone your printer is connected to in the AppleTalk Zones list.

5. Click Create.

Accessing the PostScript printer driver

To control your printer and change its settings, use the printer driver. The printer driver allows you to easily make all the print settings, including paper source, paper size, and orientation.

For Mac OS X users

To access the PostScript printer driver, register your printer in Printer Setup Utility (for Mac OS X 10.3) or Print Center (for Mac OS X 10.2), click Print on the file menu of any application, then select your printer.

For Mac OS 9 users

To access the PostScript printer driver, select Chooser from the Apple menu, then click the AdobePS icon. Select Print on the file menu of any application.

Making changes to PostScript printer settings

You can change the PostScript printer settings in the PostScript printer driver. Balloon help is available to help you with the printer driver settings.

Using Balloon Help

Follow the steps below to use Balloon Help.

1. Click the Help menu, then select Show Balloons.
2. Place your cursor over the item that you need help with. Information on that item is displayed inside a floating balloon.

Changing the printer setup settings

You can change or update the printer setup settings according to the options installed in your printer.

For Mac OS X users

Follow the steps below to change the settings.

1. Access the printer driver. The Printer List window appears.
2. Select the printer from the list.
3. Select Show Info from the Printers menu. The Printer Info dialog box appears.
4. Make necessary changes to the settings, then close the dialog box.
5. Quit Printer Setup Utility (for Mac OS X 10.3) or Print Center (for Mac OS X 10.2).

For Mac OS 9 users

Follow the steps below to change the settings.

1. Access the printer driver.
2. Click the Printing menu, then select Change Setup.

3. Change the settings using the pop-up menus.

About the PCL6 Mode

Hardware requirements

Your printer must meet the following hardware requirements to be able to use the PCL6 printer driver.

Memory requirements for using the PCL6 printer driver are shown below. Install optional memory modules into your printer if the amount of memory currently installed does not meet your printing needs.

Minimum memory	Recommended memory
64 MB* (for a simple print job at 600 dpi)	64 MB* or more

* Printing may not be possible with this amount of memory, depending on the specifics of the job being printed.

System requirements

Your computer must meet the following system requirements to be able to use the PCL6 printer driver.

To use the PCL6 printer driver, your computer must be running Microsoft Windows XP, Me, 98, 95, 2000, or NT 4.0. See the following table for details.

For Windows XP or 2000

	Minimum	Recommended
Computer	IBM PC series or IBM compatible with Pentium or higher CPU	IBM PC series or IBM compatible with Pentium II or higher CPU
Hard Disk	10-25 MB free (for driver installation)	
Memory	128 MB (256 MB for Server 2003)	256 MB

For Windows Me, 98, or 95

	Minimum	Recommended
Computer	IBM PC series or IBM compatible with an 486 or higher CPU	IBM PC series or IBM compatible with Pentium or higher CPU
Hard Disk	10 MB free (for driver installation)	
Memory	64 MB	128 MB

For Windows NT 4.0

	Minimum	Recommended
Computer	IBM PC series or IBM compatible with an 486 or higher CPU	IBM PC series or IBM compatible with Pentium II or higher CPU
Hard Disk	10-20 MB free (for driver installation)	
Memory	128 MB	256 MB

Using the PCL6 Printer Driver

To print in the PCL6 mode, you will have to install the printer driver. Consult the customer support in your region regarding how to get the printer driver.

Note:

The PCL6 printer driver and EPSON Status Monitor cannot be used at the same time.

Using the Control Panel

Using the Control Panel Menus

You can use the printer's control panel to access a variety of menus that allow you to check the status of consumable products, print status sheets, and make printer settings. This section describes how to use the control panel menus, and when it is appropriate to make printer settings using the control panel.

When to make control panel settings

In general, printer settings can be made from the printer driver, and do not need to be made using the control panel. In fact, printer driver settings override settings made using the control panel, so use the control panel menus only to make settings you cannot make in your software or printer driver, including the following:







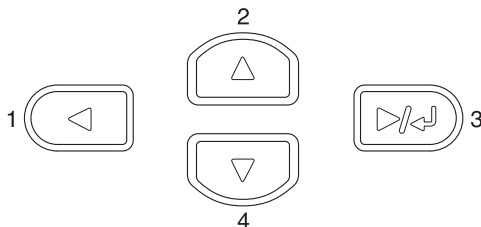

- ❑ Changing the emulation modes and selecting the IES (Intelligent Emulation Switching) mode
- ❑ Specifying a channel and configuring the interface
- ❑ Choosing the size of the memory buffer used to receive data





How to access the control panel menus

For a complete description of the items and settings available in the control panel menus, see "Control Panel Menus" on page 151.

1. When the printer's Ready light is on, press the  Enter button to access the control panel menus.



2. Use the  Up and  Down buttons to scroll through the menus.
3. Press the  Enter button to view the items in a menu. Depending on the menu, the LCD panel displays an item and the current setting separated ( YYY=ZZZ), or only an item ( YYY).
4. Use the  Up and  Down buttons to scroll through the items, or press the  Back button to return to the previous level.
5. Press the  Enter button to carry out the operation indicated by an item, such as printing a status sheet or resetting the printer, or to view the settings available for an item, such as paper sizes or emulation modes.

Use the  Up and  Down buttons to scroll through available settings, and press the  Enter button to select a setting and return to the previous level. Press the  Back button to return to the previous level without changing the setting.

Note:

You need to turn the printer off and then on to activate some settings. For details, see "Control Panel Menus" on page 151.

6. Press the  Start/Stop button to exit the control panel menus.

Control Panel Menus

Press the ▲ Up and ▼ Down buttons to scroll through the menus. The menus and menu items appear in the order shown below.

Note:

Some menus and items appear only when a corresponding optional device is installed or an appropriate setting has been done.

Information Menu

From this menu you can check the toner level and the remaining service life of consumable products. You can also print status and sample sheets showing the printer's current settings, available fonts, and a brief summary of available features.

Press the ▼ Down or ▲ Up button to select an item. Press the  Enter button to print a sheet or font sample.

Item	Settings
Status Sheet	-
Network Status Sheet	-
AUX Status Sheet* ¹	-
USB Ext I/F Status Sht* ²	-
PS3 Status Sheet	-
PS3 Font List	-
LJ4 Font Sample	-
ESCP2 Font Sample	-
FX Font Sample	-
I239X Font Sample	-
Toner	E*****F, E***** F, E***** F, E*** F, E** F, E* F, E F
Total Pages	0 to 99999999

*¹ Available only when an optional interface card is installed.

*² Available only when a USB external device with D4 support is connected and the USB I/F is set to On in the USB menu.

Status Sheet, AUX Status Sheet, PS3 Status Sheet

Prints a sheet according to the current printer settings and installed options. These sheets can be useful to confirm whether options have been installed correctly.

Network Status Sheet

Prints a sheet showing the working status of the network.

USB Ext I/F Status Sht

Prints a sheet showing the working status of the USB interface.

PS3 Font List, LJ4 Font Sample, ESCP2 Font Sample, FX Font Sample, I239X Font Sample

Prints a sample of the fonts available for your selected printer emulation.

Toner

Displays the amount of toner left in the imaging cartridges as shown below:

E*****F	(100 to 83%)
E***** F	(83 to 66%)
E**** F	(66 to 50%)
E*** F	(50 to 33%)
E** F	(33 to 16%)
E* F	(16 to 0%)
E F	(0%)

Total Pages

Displays the total number of pages printed by the printer.

Tray Menu

This menu allows you to specify the size and type of paper loaded in the MP tray. Accessing this menu also lets you check the size of the paper currently loaded in the lower paper cassettes.

The paper type settings in this menu can also be made from your printer driver. Settings you make in your printer driver override these settings, so use your printer driver whenever you can.

Item	Settings (default in bold)
MP Tray Size	Auto , A4, A3, A5, B4, B5, LT, HLT* ² , LGL, GLT* ² , GLG* ² , B* ² , EXE* ² , F4* ² , MON* ² , C10* ² , DL* ² , C5* ² , C6* ² , IB5* ²
LC1 Size/LC2 Size* ¹ /LC3 Size* ¹	A4 , A3, A5, B4, B5, LT, LGL
MP Type	Plain , Letterhead, Recycled, Color, Trnsprncy, Labels
LC1 Type/LC2 Type* ¹ /LC3 Type* ¹	Plain , Letterhead, Recycled, Color

*¹ Displayed only when the optional 550-Sheet Universal Paper Cassette Unit is installed.

*² These sizes cannot be detected automatically. Set the size according to the paper size you want to use.

MP Tray Size

Select your paper size from this menu.

When **Auto** is selected, all kinds of available paper size are detected automatically. Select the proper size to use other size paper.

LC1 Size/LC2 Size/LC3 Size

Displays the paper size loaded in the standard and optional lower paper cassettes.

MP Type

Lets you set the paper type loaded in the MP tray.

LC1 Type/LC2 Type/LC3 Type

Lets you select the paper type loaded in the standard and optional lower paper cassettes.

Emulation Menu

Use this menu to select the printer emulation mode. You can specify different emulations for each interface; in other words, for each computer you connect the printer to. Since each emulation mode has its own specific options, make settings in the LJ4, ESCP2, FX, I239X, or PS3 menu, as necessary. The settings you can choose from are the same for every interface.

Item	Settings (default in bold)
Parallel	Auto , LJ4, ESCP2, FX, I239X, PS3
USB	Auto , LJ4, ESCP2, FX, I239X, PS3
Network	Auto , LJ4, ESCP2, FX, I239X, PS3
AUX*	Auto , LJ4, ESCP2, FX, I239X, PS3

* Available only when an optional Type-B interface card is installed.

Printing Menu

This menu allows you to make standard print settings, such as Page Size and Orientation, when printing from an application or operating system that does not support your printer driver. Be sure to use the printer driver to make these settings whenever you can, since settings made on your computer always override these settings.

Item	Settings (default in bold)
Page Size	A4 ^{*1} , A3, A5, B4, B5, LT, HLT, LGL, GLT, GLG, B, EXE, F4, MON, C10, DL, C5, C6, IB5, CTM
Wide A4	Off , On
Orientation	Port , Land
Resolution	600 , 300
RI Tech	On , Off
Toner Save	Off , On
Density	1, 2, 3 , 4, 5
Image Optimum	Auto , Off, On
Top Offset	-150.0 to 0.0 to 150.0 mm in 0.5 increments
Left Offset	-150.0 to 0.0 to 150.0 mm in 0.5 increments
T Offset B ^{*2}	-150.0 to 0.0 to 150.0 mm in 0.5 increments
L Offset B ^{*2}	-150.0 to 0.0 to 150.0 mm in 0.5 increments

*1 Depends on factory setting.

*2 Available only when optional Duplex Unit is installed.

Page Size

Specifies the paper size.

Wide A4

Selecting **On** decreases the left and right margins from 4 mm to 3.4 mm.

Orientation

Specifies whether the page is printed in portrait or landscape orientation.

Resolution

Specifies the printing resolution.

RITech

Turning RITech on produces smoother and crisper lines, text, and graphics.

Toner Save

When this setting is selected, the printer saves toner by substituting a gray shade for the black inside of characters. The characters are outlined in full black on the right and lower edges.

Density

Specifies the printing density.

Image Optimum

When this mode is on, the quality of graphics is reduced. It reduces the amount of graphics data when the data reaches the memory limit, allowing complex documents to be printed.

Top Offset

Makes fine adjustments to the vertical printing position of the page.



Caution:

Make sure that the printed image does not extend beyond the edge of the paper. Otherwise, you may damage the printer.

Left Offset

Makes fine adjustments to the horizontal printing position of the page. This is useful for fine adjustments.



Caution:

Make sure that the printed image does not extend beyond the edge of the paper. Otherwise, you may damage the printer.

T Offset B

Adjusts the vertical printing position on the back of the paper when printing on both sides. Use this if the printout on the back is not where you expected.

L Offset B

Adjusts the horizontal printing position on the back of the paper when printing on both sides. Use this if the printout on the back is not where you expected.

Setup Menu

This menu allows you to make various basic configuration settings related to paper sources, feeding modes, and error handling. You can also use this menu to select the LCD panel display language.

Item	Settings (default in bold)
Lang	English , Français, Deutsch, ITALIANO, ESPAÑOL, SVENSKA, Dansk, Nederl., SUOMI, Português, Norsk, CATALÀ
Time to Sleep	5 , 15, 30, 60, 120, 180, 240 Min
Time Out	0, 5 to 60 to 300 in increments of 1
Paper Source	Auto , MP, LC1, LC2 ^{*1} , LC3 ^{*1}
MP Mode	Normal , Last
Manual Feed	Off , 1st Page, Each Page
Copies	1 to 999
Duplex ^{*1}	Off , On
Binding ^{*1}	Long Edge , Short Edge
Start Page ^{*1}	Front , Back
Paper Type	Normal , Thick, Extra Thk, Trnsprnc
Skip Blank Page ^{*2}	Off , On
Auto Eject Page	Off , On
Size Ignore	Off , On
Auto Cont	Off , On
Page Protect	Auto , On
Toner Out	Stop , Continue
LCD Contrast	0 to 7 to 15

*1 Available only when optional Duplex Unit is installed.

*2 Available only when in ESCP2 or I239X mode.

Lang

Specifies the language displayed on the LCD panel and that printed on the status sheet.

Time to Sleep

Specifies the length of time until the printer enters the sleep mode if there are no printing or control panel operations.

Time Out

Specifies the length of the time the printer waits when it is ready to print and no new data is received. When this time is up, the printer searches for new print data from other interfaces.

Paper Source

Specifies whether paper feeds into the printer from the MP tray or the optional lower paper cassette unit.

If you select `Auto`, paper feeds from the paper source containing paper that matches your Paper Size setting.

If an envelope size (IB5, C10, C6, DL, MON, C5) is selected as the Page Size setting, paper always feeds from the MP tray. If you select `Thick`, `Extra Thk`, or `Transpnc` as the Paper Type setting, paper always feeds from the MP tray.

MP Mode

This setting determines whether the MP tray has the highest or lowest priority when `Auto` is selected as the Paper Source setting in the printer driver. When `Normal` is selected as the MP Mode, the MP tray has the highest priority as the paper source. If you select `Last`, the MP tray has the lowest priority.

Manual Feed

Allows you to select the manual feed mode for the MP tray. If you select **Off**, the manual feed mode is disabled and the printer starts printing immediately when a job is received. If you select **1st Page**, the printer doesn't start printing when a job is received but starts printing after you press the **Start/Stop** button. If you select **Each Page**, the printer doesn't start printing when a job is received and then prints pages one by one each time you press the **Start/Stop** button.

Copies

Designates the number of copies to be printed, from 1 through 999.

Duplex

Turns duplex printing on or off. This allows you to print on both sides of a page.

Binding

Specifies the binding direction of the printout.

Start Page

Specifies whether printing starts from the front or back of the page.

Paper Type

Specifies the type of paper to be used for printing. The printer adjusts the printing speed according to this setting. The printing speed is reduced when **Thick**, **Extra Thk**, or **TransPnc** is selected.

Skip Blank Page

Enables you to skip blank pages when printing. This setting is available when you print in the **ESCP2** or **I239X** mode.

Auto Eject Page

Specifies whether or not to eject paper when the limit specified in the Time Out setting is reached. The default is `Off`, which means paper is not ejected when the time-out limit is reached.

Size Ignore

If you want to ignore a paper size error, select `On`. When you turn this item on, the printer keeps printing even if the image size exceeds the printable area for the specified paper size. This may cause smudges because of the toner that is not transferred onto the paper properly. When this item is turned off, the printer stops printing if a paper size error occurs.

Auto Cont

When you turn this setting on, the printer automatically continues printing after a certain period of time when one of the following errors occurs: Paper Set, Print Overrun, or Mem Overflow. When this option is off, you must press the `Start/Stop` button to resume printing.

Page Protect

Allocates additional printer memory for printing data, as opposed to receiving it. You may need to turn this setting on if you are printing a very complex page. If a `Print Overrun` error message appears on the LCD panel during printing, turn this setting on and reprint your data. This reduces the amount of memory reserved for processing data so your computer may take longer to send the print job, but it will allow you to print complex jobs. Page Protect usually works best when `Auto` is selected. You will need to increase your printer's memory if memory errors continue to occur.

Note:

Changing the Page Protect setting reconfigures the printer's memory, which causes any downloaded fonts to be deleted.

Toner Out

If this item is set to **Stop**, the printer displays an error message, **Replace Toner**, to let you know when the toner is out. See "Status and Error Messages" on page 181. To disable this function, set this item to **Continue**.

Note:

- ❑ *If you set **Stop** and a toner out error occurs, you can restart printing by pressing the **Start/Stop** button. The printout continues until another 100 sheets are printed or the current job is finished. The print result may be different from what you expected because there may not be enough toner to print the data.*
- ❑ *If this item is set to **Continue**, the print result may be different from what you expected because there may not be enough toner to print the data.*

LCD Contrast

Adjusts the contrast of the LCD panel. Use the **▲ Up** and **▼ Down** buttons to set the contrast between 0 (lowest contrast) and 15 (highest contrast.)

Reset Menu

This menu allows you to cancel printing and reset the printer settings.

Clear Warning

Clears warning messages that show errors except for these that occur from consumable products or mandatory-replacement parts.

Clear All Warnings

Clears all warning messages that appear on the LCD panel.

Reset

Stops printing and clears the current job received from the active interface. You may want to reset the printer when there is a problem with the print job itself and the printer cannot print successfully.

Reset All

Stops printing, clears the printer memory, and restores the printer settings to their default values. The print jobs received from all interfaces are erased.

Note:

Performing Reset All clears print jobs received from all interfaces. Be careful not to interrupt someone else's job.

SelecType Init

Restores the control panel menu settings to their default values.

Reset Fuser Counter

Reset the fuser unit life counter when you replace the fuser unit.

Parallel Menu

These settings control communication between the printer and the computer when using the parallel interface.

Item	Settings (default in bold)
Parallel I/F*	On , Off
Speed*	Fast , Normal
Bi-D*	Nibble, ECP , Off
Buffer Size*	Normal , Maximum, Minimum

* After this item is changed, the setting value takes effect after a warm boot or after the power is turned on again. While it is reflected in the Status Sheet and EJL read-back, the actual change takes effect after a warm boot or after the power is turned on again.

Parallel I/F

Allows you to activate or deactivate the parallel interface.

Speed

Specifies the pulse width of the ACKNLG signal when receiving data in the Compatibility mode or Nibble mode. When **Fast** is selected, the pulse width is about 1 μ s. When **Normal** is selected, the pulse width is about 10 μ s.

Bi-D

Allows you to specify the bidirectional communication mode. When you select **Off**, bidirectional communication is disabled.

Buffer Size

Determines the amount of memory to be used for receiving data and printing data. If **Maximum** is selected, more memory is allocated for receiving data. If **Minimum** is selected, more memory is allocated for printing data.

Note:

- ❑ *To activate Buffer Size settings, you must turn off the printer for more than five seconds then turn it back on. Or, you can perform a Reset All operation, as explained in "Reset Menu" on page 163.*

- ❑ *Resetting the printer erases all print jobs. Make sure the Ready light is not flashing when you reset the printer.*

USB Menu

These settings control communication between the printer and the computer when using the USB interface.

Item	Settings (default in bold)
USB I/F ^{*1}	On , Off
USB ExtI/F Config ^{*2}	No , Yes
Get IP Address ^{*3}	Panel, Auto , PING
IP ^{*3*4*5}	0.0.0.0 to 255.255.255.255
SM ^{*3}	0.0.0.0 to 255.255.255.255
GW ^{*3}	0.0.0.0 to 255.255.255.255
NetWare ^{*3}	On, Off
AppleTalk ^{*3}	On, Off
MS Network ^{*3}	On, Off
Rendezvous ^{*3}	On, Off
USB Ext I/F Init ^{*3}	-
Buffer Size ^{*1}	Normal , Maximum, Minimum

^{*1} After this item is changed, the setting value takes effect after a warm boot or after the power is turned on again. While it is reflected in the Status Sheet and EJL read-back, the actual change takes effect after a warm boot or after the power is turned on again.

^{*2} Available only when a USB external device with D4 support is connected. The **USB Config** setting is set to **No** automatically when exiting the panel settings.

^{*3} Available only when a USB external device with D4 support is connected and the **USB Config** setting is set to **Yes**. The contents of the settings depend on the USB external device settings.

^{*4} Available only when the **Get IPAddress** setting is set to **Auto**. This setting cannot be changed.

^{*5} When the **Get IPAddress** setting is changed from **Panel** or **PING** to **Auto**, the panel setting values are saved. When **Auto** is changed to **Panel** or **PING**, the saved setting values are displayed. 192.168.192.168 if the settings are not made from the panel.

USB I/F

Allows you to activate or deactivate the USB interface.

Buffer Size

Determines the amount of memory to be used for receiving data and printing data. If **Maximum** is selected, more memory is allocated for receiving data. If **set to Minimum** is selected, more memory is allocated for printing data.

Note:

- ❑ *To activate Buffer Size settings, you must turn off the printer for more than five seconds then turn it back on. Or, you can perform a Reset All operation, as explained in "Reset Menu" on page 163.*
- ❑ *Resetting the printer erases all print jobs. Make sure the Ready light is not flashing when you reset the printer.*

Network Menu

See the *Network Guide* for each setting.

AUX Menu

See the *Network Guide* for each setting.

LJ4 Menu

These settings control the fonts and symbol sets when in the LJ4 mode.

Item	Settings (default in bold)
FontSource	Resident , Download* ¹ , ROM A* ²
Font Number	0 to 65535 (depending on your settings)
Pitch* ⁴	0.44 ... 10.00 ... 99.99 cpi in 0.01-cpi increments
Height* ⁴	4.00 ... 12.00 ... 999.75 pt in 0.25-pt increments
SymSet	IBM-US , Roman-8, Roman-9, ECM94-1, 8859-2 ISO, 8859-9 ISO, 8859-10ISO, 8859-15ISO, PcBlt775, IBM-DN, PcMultifiling, PcE.Europe, PcTk437, PcEur858, Pc1004, WiAnsi, WiE.Europe, WiTurkish, WiBALT, DeskTop, PsText, VeInternati, VeUS, MsPublishin, Math-8, PsMath, VeMath, PiFont, Legal, UK, ANSI ASCII, Swedis2, Italian, Spanish, German, Norweg1, French2, Windows, McText, Hebrew7, 8859-8 ISO, Hebrew8, Arabic8, OCR A, OCR B, Pc866Cyr, Pc866Ukr, WinCyr, ISOCyr, Pc8Grk, Pc851Grk, WinGrk, ISOGrk, Greek8, Pc862Heb, Pc864Ara, HPWARA
Form	5 ... 60/64 * ³ ... 128 lines
CR Function	CR , CR + LF
LF Function	LF , CR + LF
Tray Assign	4K , 5S, 4

*¹ Available only when downloaded fonts exist.

*² Available only when the optional font ROM module is installed.

*³ Depending on whether Letter (60) or A4 (64) paper has been selected.

*⁴ Depending on which font is selected.

Note:

If you normally use the PCL printer driver when printing, you should change settings using this driver whenever you can. Printer driver settings always override the LJ4 Menu options.

FontSource

Sets the default font source.

Font Number

Sets the default font number for the default font source. The available number depends on the settings you made.

Pitch

Specifies the default font pitch if the font is scalable and of fixed-pitch. You can select from 0.44 to 99.99 cpi (characters per inch), in 0.01-cpi increments. This item may not appear depending on the Font Source or Font Number settings.

Height

Specifies the default font height if the font is scalable and proportional. You can select from 4.00 to 999.75 points, in 0.25-point increments. This item may not appear depending on the Font Source or Font Number settings.

SymSet

Selects the default symbol set. If the font you selected in Font Source and Font Number is not available in the new SymSet setting, the Font Source and the Font Number settings are automatically replaced with the default value, IBM-US.

Form

Selects the number of lines for the selected paper size and orientation. This also causes a line spacing (VMI) change, and the new VMI value is stored in the printer. This means that later changes in the Page Size or Orientation settings cause changes in the Form value, based on the stored VMI.

CR Function, LF Function

These functions are included for users of particular operating systems, such as UNIX.

Tray Assign

Changes the assignment for the paper source select command. When **4** is selected, the commands are set as compatible with the HP LaserJet 4. When **4K** is selected, the commands are set as compatible with the HP LaserJet 4000, 5000, and 8000. When **5S** is selected, the commands are set as compatible with the HP LaserJet 5Si.

PS3 Menu

This menu allows you to make settings which affect the printer when it is in the PS3 mode.

Item	Settings (default in bold)
Error Sheet	Off , On
Image Protect	Off , On
Binary	Off , On
Text Detection	Off , On

Error Sheet

When you select **On**, the printer prints out an error sheet.

Image Protect

The printer employs lossy compression when **Off** is selected. The printer does not employ lossy compression when **On** is selected. Lossy compression refers to a data compression technique in which some amount of data is lost.

Binary

Specifies the data format. Select **On** for the Binary data and select **Off** for the ASCII data.

Note:

- Binary can only be used with network connection.*
- You do not have to select On when using AppleTalk.*

To use the Binary data, make sure your application supports Binary data and that SEND CTRL-D Before Each Job and SEND CTRL-D After Each Job are set to No.

When this setting is set to On, you cannot use TBCP (Tagged binary communication protocol) and Job Management in the printer driver settings.

Text Detection

When you select On, the text file is converted to a postscript file when printing. This setting is available only when you select P^S3 in the Emulation Menu.

ESCP2 Menu

This menu allows you to make settings which affect the printer when it is in the ESC/P 2 emulation mode.

Item	Settings (default in bold)
Font	Courier , Prestige, Roman, Sans Serif, Roman T, Orator S, Sans H, Script, OCR A, OCR B
Pitch	10 , 12, 15 cpi, Prop.
Condensed	Off , On
T. Margin	0.40 ... 0.50 ... 1.50 inches in 0.05-inch increments
Text	1... 62/66 *... 117lines
CGTable	PcUSA , Italic, PcMultilin, PcPortugue, PcCanFrenc, PcNordic, PcTurkish2, Pclcelandic, PcE.Europe, BpBRASCII, BpAbicomp, Roman-8, PcEur858, ISO Latin1, 8859-15ISO, PcSI437, PcTurkish1, 8859-9 ISO, Mazowia, CodeMJK, PcGk437, PcGk851, PcGk869, 8859-7 ISO, PcCy855, PcCy866, PcUkr866, PcLit771, Bulgarian, Hebrew7, Hebrew8, PcHe862, PcAr864, PcAr864Ara, PcAr720, PcLit774, Estonia, ISO Latin2, PcLat866
Country	USA , France, Germany, UK, Denmark, Sweden, Italy, Spain1, Japan, Norway, Denmark2, Spain2, LatinAmeric, Korea, Legal
Auto CR	On , Off
Auto LF	Off , On
Bit Image	Dark , Light, BarCode
ZeroChar	0 , (or the zero character with a slash)

* Depending on whether Letter (62) or A4 (66) paper has been selected.

Font

Selects the font.

Pitch

Selects the pitch (the horizontal spacing) of the font in fixed pitch, measured in cpi (characters per inch). You can also choose proportional spacing.

Condensed

Turns condensed printing on or off.

T. Margin

Sets the distance from the top of the page to the baseline of the first printable line. The distance is measured in inches. The smaller the value, the closer the printable line is to the top.

Text

Sets the page length in lines. For this option, a line is assumed to be 1 pica (1/6 inch). If you change the Orientation, Page Size, or T. Margin settings, the page length setting automatically returns to the default for each paper size.

CG Table

Use the character generator (CG) table option to select the graphics character table or the italics table. The graphics table contains graphic characters for printing lines, corners, shaded areas, international characters, Greek characters, and mathematical symbols. If you select *Italic*, the upper half of the character table is defined as italic characters.

Country

Use this option to select one of the fifteen international symbol sets. See "International character sets" on page 327 for samples of the characters in each country's symbol set.

Auto CR

Specifies whether the printer performs a carriage-return/line-feed (CR-LF) operation whenever the printing position goes beyond the right margin. If you select `Off`, the printer does not print any characters beyond the right margin and does not perform any line wrapping until it receives a carriage-return character. This function is handled automatically by most applications.

Auto LF

If you select `Off`, the printer does not send an automatic line-feed (LF) command with each carriage-return (CR). If `On` is selected, a line-feed command is sent with each carriage-return. Select `On` if your text lines overlap.

Bit Image

The printer is able to emulate the graphics densities set with the printer commands. If you select `Dark`, the bit image density is high, and if you select `Light`, the bit image density is low.

If you select `BarCode`, the printer converts bit images to bar codes by automatically filling in any vertical gaps between dots. This produces unbroken vertical lines that can be read by a bar code reader. This mode will reduce the size of the image being printed, and may also cause some distortion when printing bit image graphics.

ZeroChar

Specifies whether the printer prints a slashed or unslashed zero.

FX Menu

This menu allows you to make settings which affect the printer when it is in the FX emulation mode.

Item	Settings (default in bold)
Font	Courier , Prestige, Roman, Sans Serif, Script, Orator S, OCR A, OCR B
Pitch	10 , 12, 15 cpi, Prop.
Condensed	Off , On
T. Margin	0.40 ... 0.50 ... 1.50 inches in 0.05-inch increments
Text	1... 62/66 *... 117lines
CGTable	PcUSA , Italic, PcMultilin, PcPortugue, PcCanFrenc, PcNordic, PcTurkish2, Pclcelandic, PcE.Europe, BpBRASCII, BpAbicomp, Roman-8, PcEur858, ISO Latin1, 8859-15ISO
Country	USA , France, Germany, UK, Denmark, Sweden, Italy, Spain1, Japan, Norway, Denmark2, Spain2, LatinAmeric
Auto CR	On , Off
Auto LF	Off , On
Bit Image	Dark , Light, BarCode
ZeroChar	0 , (or the zero character with a slash)

* Depending on whether Letter (62) or A4 (66) paper has been selected.

Font

Selects the font.

Pitch

Selects the pitch (the horizontal spacing) of the font in fixed pitch, measured in cpi (characters per inch). You can also choose proportional spacing.

Condensed

Turns condensed printing on or off.

T. Margin

Sets the distance from the top of the page to the baseline of the first printable line. The distance is measured in inches. The smaller the value, the closer the printable line is to the top.

Text

Sets the page length in lines. For this option, a line is assumed to be 1 pica (1/6 inch). If you change the Orientation, Page Size, or T. Margin settings, the page length setting automatically returns to the default for each paper size.

CG Table

Use the character generator (CG) table option to select the graphics character table or the italics table. The graphics table contains graphic characters for printing lines, corners, shaded areas, international characters, Greek characters, and mathematical symbols. If you select *Italic*, the upper half of the character table is defined as italic characters.

Country

Use this option to select one of the fifteen international symbol sets. See "International character sets" on page 327 for samples of the characters in each country's symbol set.

Auto CR

Specifies whether the printer performs a carriage-return/line-feed (CR-LF) operation whenever the printing position goes beyond the right margin. If you select *Off*, the printer does not print any characters beyond the right margin and does not perform any line wrapping until it receives a carriage-return character. This function is handled automatically by most applications.

Auto LF

If you select `Off`, the printer does not send an automatic line-feed (LF) command with each carriage-return (CR). If `On` is selected, a line-feed command is sent with each carriage-return. Select `On` if your text lines overlap.

Bit Image

The printer is able to emulate the graphics densities set with the printer commands. If you select `Dark`, the bit image density is high, and if you select `Light`, the bit image density is low.

If you select `BarCode`, the printer converts bit images to bar codes by automatically filling in any vertical gaps between dots. This produces unbroken vertical lines that can be read by a bar code reader. This mode will reduce the size of the image being printed, and may also cause some distortion when printing bit image graphics.

ZeroChar

Selects whether the printer prints a slashed or unslashed zero.

I239X Menu

The I239X mode emulates IBM[®] 2390/2391 Plus commands.

These settings are available only when the printer is in the I239X mode.

Item	Settings (default in bold)
Font	Courier , Prestige, Gothic, Orator, Script, Presentor, Sans Serif
Pitch	10 , 12, 15, 17, 20, 24 cpi, Prop.
Code Page	437 , 850, 858, 860, 863, 865
T. Margin	0.30 ... 0.40 ... 1.50 inches in 0.05-inch increments
Text	1 ... 63/67 ^{*1} ... 117lines
Auto CR	Off , On
Auto LF	Off , On
Alt. Graphics	Off , On
Bit Image	Dark , Light
ZeroChar	0 , (or the zero character with a slash)
CharacterSet	1 ^{*2} , 2 ^{*2}

*1 Depending on whether Letter (63) or A4 (67) paper has been selected.

*2 Depending on whether Letter (1) or A4 (2) paper has been selected.

Font

Selects the font.

Pitch

Selects the pitch (the horizontal spacing) of the font in fixed pitch, measured in cpi (characters per inch). You can also choose proportional spacing.

Code Page

Selects the character tables. Character tables contain the characters and symbols used by different languages. The printer prints text based on the selected character table.

T. Margin

Sets the distance from the top of the page to the baseline of the first printable line. The distance is measured in inches. The smaller the value, the closer the printable line is to the top.

Text

Sets the page length in lines. For this option, a line is assumed to be 1 pica (1/6 inch). If you change the Orientation, Page Size, or T. Margin settings, the page length setting automatically returns to the default for each paper size.

Auto CR

Specifies whether the printer performs a carriage-return/line-feed (CR-LF) operation whenever the printing position goes beyond the right margin. If this setting is off, the printer does not print any characters beyond the right margin and does not perform any line wrapping until it receives a carriage-return character. This function is handled automatically by most applications.

Auto LF

If you select `Off`, the printer does not send an automatic line-feed (LF) command with each carriage-return (CR). If `On` is selected, a line-feed command is sent with each carriage-return. Select `On` if your text lines overlap.

Alt.Graphics

Turns the Alternate Graphics option on or off.

Bit Image

The printer is able to emulate the graphics densities set with the printer commands. If you select `Dark`, the bit image density is high, and if you select `Light`, the bit image density is low.

If you select `BarCode`, the printer converts bit images to bar codes by automatically filling in any vertical gaps between dots. This produces unbroken vertical lines that can be read by a bar code reader. This mode will reduce the size of the image being printed, and may also cause some distortion when printing bit image graphics.



ZeroChar

Selects whether the printer prints a slashed or unslashed zero.

CharacterSet

Selects character table 1 or 2.

Status and Error Messages

This section contains a list of error messages shown on the LCD panel, giving a brief description of each message and suggestions for correcting the problem. Note that not every message shown on the LCD panel indicates a problem. When the  mark is displayed at the left of the warning message, multiple warnings occur. To confirm all warnings that occur, press the  Down button to display the Status Menu, then press the  Enter button. The LCD panel also displays the amounts of remaining toners.

Cancel All Print Job

The printer is canceling all print jobs in the printer memory, including jobs the printer is currently receiving or printing. This message appears when the  Cancel Job button has been pressed down for more than 2 seconds.

Cancel Print Job



The printer is canceling the current print job. This message appears when the  Cancel Job button has been pressed and released within 2 seconds.

Can't Print

The print data is deleted because it is incorrect.

Make sure that the appropriate paper size is set and a printer driver for EPSON EPL-N2550 is used.

Can't Print Duplex

The printer has encountered problems during duplex printing. Make sure you are using an appropriate type and size of paper for the Duplex Unit. The problem could also be a result of incorrect settings for the paper source you are using. Pressing the  Start/Stop button will print the rest of the print job on only one side of the paper. Press the  Cancel Job button to cancel the print job.

Cart Near Expiry

The imaging cartridge is nearing the end of its functional life.

Replacing it with a new imaging cartridge is strongly recommended. See "Imaging Cartridge" on page 213 for instructions.

Check Duplex P-Size

The paper size loaded in the printer is not appropriate for the optional Duplex Unit.

Load correct the paper size and press  Start/Stop button to resume printing.

Check Paper Size

The paper size setting is different from the size of paper loaded in the printer. Check to see if the correct size of paper is loaded in the specified paper source.

To clear this error, select **Clear Warning** from the control panel's Reset Menu. See "How to access the control panel menus" on page 149 for instructions.

Check Paper Type

The media loaded in the printer does not match the paper type setting in the printer driver. Media that matches only the paper size setting will be used for printing.

To clear this error, select **Clear Warning** from the control panel's Reset Menu. See "How to access the control panel menus" on page 149 for instructions.

Collate disabled

Printing by specifying the number of copies is no longer possible due to a lack of memory (RAM). If this error occurs, print only one copy at a time.

To clear this error, select **Clear Warning** from the control panel's Reset Menu. See "How to access the control panel menus" on page 149 for instructions.

Cooling Down

The printer lowers its temperature to optimize for the fixing toner. Wait for a moment for **Ready** to appear in the LCD panel.

DM Error 001

The Duplex Unit has become separated from the printer. Turn the printer off, reinstall the Duplex Unit and turn the printer on again.

DM Open

The Duplex Unit's cover is open.

Duplex Mem Overflow

There is not enough memory for duplex printing. The printer prints only on the front and ejects the paper. To clear this error, follow the instructions below.

If **Off** is selected as the Auto Cont setting on the control panel's Setup Menu, press the **Start/Stop** button to print on the back of the next sheet, or press the **Cancel Job** button to cancel the print job.

If **On** is selected as the Auto Cont setting on the control panel's Setup Menu, printing continues automatically after a certain period of time.

Form Feed

The printer is ejecting paper due to a user request. This message appears when pressing the **Start/Stop** button once to make the printer offline, and then holding down the **Start/Stop** button for more than 2 seconds in order not to receive form feed command.

Image Optimum

There is insufficient memory to print the page at the specified print quality. The printer automatically lowers the print quality so that it can continue printing. If the quality of the printout is not acceptable, try simplifying the page by limiting the number of graphics or reducing the number and size of fonts.

To clear this error, select **Clear Warnings** from the control panel's Reset Menu. See "How to access the control panel menus" on page 149 for instructions.

Turn the **Image Optimum** setting off on the control panel's Printing Menu if you do not want the printer to automatically lower the print quality to continue printing.

You may need to increase the amount of printer memory to be able to print at the desired print quality for your document. For more information on adding memory, see "Memory Module" on page 202.

Install Imaging Cart

The imaging cartridge is not installed or not installed correctly. Make sure that the imaging cartridge is installed correctly.

Invalid AUX I/F Card

This message means that the printer cannot communicate with the installed optional interface card. Turn off the printer, remove the card, then reinstall it.

Invalid N/W Module

There is no network program, or the network program cannot be used with your printer. Contact a qualified service representative.

Invalid PS3

The PostScript3 ROM module is broken. Turn off the printer and contact your dealer.



To clear this error, either press the **Start/Stop** button or turn off the printer and remove the ROM module, then reinstall the ROM module. If that fails to clear the error, contact your dealer.

Manual Feed xxx

The manual feed mode is specified for the current print job. Make sure the paper size indicated by xxx is loaded, then press the **Start/Stop** button.

If you do not want to print this job in manual mode, press the  Cancel Job button.

Mem Overflow

The printer has insufficient memory to execute the current task. Press the  Start/Stop button on the control panel to resume printing. Or press the  Cancel Job button to cancel the print job.

Menus Locked

This message appears if you try to change the printer's settings through the control panel when the buttons are locked. You can unlock them by using the Network utility. Refer to the Network Guide for information.

Need Memory

The printer has insufficient memory to complete the current print job. Cancel printing by deleting it from the print queue on your computer, or by pressing the  Cancel Job button on the printer.

To clear this error message, select **Clear Warnings** from the control panel's Reset Menu. See "How to access the control panel menus" on page 149 for instructions.

To prevent this problem from happening again, add more memory to your printer as described in "Memory Module" on page 202.



NonGenuine Toner

The installed imaging cartridge is not a genuine Epson product. Installing a genuine imaging cartridge is recommended. Using a non-genuine imaging cartridge may affect print quality. Epson shall not be liable for any damages or problems arising from the use of consumable products not manufactured or approved by Epson.

Offline

The printer is not ready to print. Press the  Start/Stop button.

Paper Jam XXX

The location where the paper jam occurred is displayed at .  indicates the location of the error.

If a paper jam occurs at two or more locations simultaneously, the corresponding multiple locations are displayed.

Jam A	Paper is jammed at the Cover A. For instructions on how to remove jammed paper at the Cover A, see "Jam A (Cover A)" on page 232.
Jam A B	Paper is jammed inside the output path cover (cover A or B) or fuser unit. For instructions on how to remove jammed paper at the output path cover or fuser unit, see "Jam A B (Cover A or B)" on page 235.
Jam MP A Jam C1 A Jam C2 A Jam C3 A	Paper is jammed inside the optional lower paper cassette. For instructions on how to remove jammed paper in the optional lower paper cassette, see "Jam MP A, Jam C1 A, Jam C2 A, Jam C3 A (All paper cassettes and Cover A)" on page 242.
Jam DM	Paper is jammed inside the optional Duplex Unit's paper path or cover (cover DM). For instructions on how to remove jammed paper at the Duplex Unit, see "Jam DM (Cover DM)" on page 240.

Paper Out XXXXX YYYY

There is no paper in the specified paper source (XXXXX). Load paper of the indicated size (YYYY) into the paper source.

Paper Set XXXXX YYYY

The paper loaded in the specified paper source (XXXXX) does not match the required paper size (YYYY). Replace the loaded paper with the correct size paper and press the **○ Start/Stop** button to resume printing. Or press the **⏏ Cancel Job** button to cancel the print job.

If you press the **○ Start/Stop** button without replacing the paper, the printer will print on the loaded paper even though it does not match the required size.

Print Overrun

The required time to process the print data exceeded the print engine speed because the current page is too complex. Press the **○ Start/Stop** button to resume printing. Or press the **⏏ Cancel Job** button to cancel the print job. If this message appears again, select **Off** as the Page Protect setting in the control panel's Setup Menu.

If you continue to receive this message when printing a particular page, try simplifying the page by limiting the number of graphics or reducing the number and size of fonts.

You can also add more memory to the printer as described in "Memory Module" on page 202.

RAM Check

The printer is checking the RAM.

Ready

The printer is ready to receive data and print.

Replace Toner

The toner has run out.

Install a new imaging cartridge. See "Imaging Cartridge" on page 213 for instructions.

This error is not displayed when the Toner Out setting is set to *Continue* in the control panel setting. When the Toner Out setting is set to *Continue*, replace the imaging cartridge if the printout is light or faint.

Reset

The printer's current interface has been reset and the buffer has been cleared. However, other interfaces are still active and retain their settings and data.

Reset All

All printer settings have been reset to the default configuration, or to the last settings that were saved.

Reset to Save

A control panel menu setting was changed while the printer was printing. Press the  Start/Stop button to clear this message. The setting will become effective after printing has finished.

ROM Check

The printer is checking the ROM.

Self Test

The printer is performing a quick internal check.

Service Req xyyyy

A controller error or a print engine error has been detected. Turn off the printer. Wait at least 5 seconds and then turn it back on. If the error message still appears, write down the error number listed on the LCD panel (xyyyy) and turn off the printer, unplug the power cord, and contact a qualified service representative.

Sleep

Printing operations are completely suspended.

Toner Low

The imaging cartridge is running out of toner. If the printout is too light or faint, replace the imaging cartridge as described in "Imaging Cartridge" on page 213.

You can continue to print until the **Replace Toner** error message appears. Waiting until this message appears before replacing the toner is recommended as toner may spill during replacement if toner remains in the cartridge. When printouts become faint, see "Imaging Cartridge" on page 213 for instructions.

To clear this error, select **Clear Warning** from the control panel's Reset Menu. See "How to access the control panel menus" on page 149 for instructions.

Turn Paper XX

The direction of the paper loaded in the specified paper source (XX) does not match the required paper direction. Turn the paper direction to landscape.

Unable Clear Error

The printer cannot clear an error message because the error status still remains. Try solving the problem again.

Warming Up

The printer is warming up.

Worn Fuser

This message indicates that the fuser unit is near the end of its service life. Printing after this message appears is not guaranteed. Turn the printer off, then reinstall the unit after it has cooled off (40 minutes). Then replace the fuser unit with a new one. See "Fuser Unit" on page 217 for instructions.

The error clears automatically after you replace the unit and close all printer covers.

Write Error ROM A/Write Error ROM P

This message indicates an internal error in the printer. Reset the printer. If this error persists, consult your dealer.

Writing ROM A/Writing ROM P

This message indicates that a ROM module in slot is being written. Please wait until this message disappears.

Wrong Toner

The wrong imaging cartridge has been installed. Replace it with the correct imaging cartridge for this printer. See "Imaging Cartridge" on page 213 for instructions.

XXX Open

One or more of the following covers are open; Cover A, Cover B, or Duplex Unit's cover.

Printing a Status Sheet

To confirm the current status of the printer, and that the options are installed correctly, print a status sheet using the printer's control panel.

Follow the steps below to print a status sheet.

1. Turn on the printer. The LCD panel shows *Ready*.
2. Press the  Enter button three times. The printer prints a status sheet.

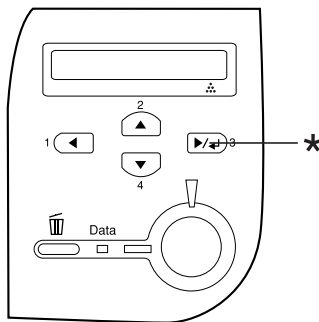

* Enter button

3. Confirm that the information about the installed options is correct. If the options are installed correctly, they appear under *Hardware Configurations*. If the options are not listed, try reinstalling them.

Note:



- ❑ *If the status sheet does not list your installed options correctly, make sure that they are securely connected to the printer.*
- ❑ *If you are unable to get the printer to print a correct status sheet, contact your dealer.*

Canceling Printing

You can cancel printing from your computer by using the printer driver.

To cancel a print job before it is sent from your computer, see "Canceling Printing" on page 104.





Using the Cancel Job button

The  Cancel Job button on your printer is the quickest and easiest way to cancel printing. Pressing this button cancels the currently printing job. Pressing the  Cancel Job button for more than two seconds deletes all jobs from the printer memory, including jobs the printer is currently receiving or printing.

Using the Reset menu

Selecting **Reset** from the control panel's Reset Menu stops printing, clears the print job being received from the active interface, and clears errors that may have occurred at the interface.

Follow the steps below to use the Reset Menu.

1. Press the  Enter button to access the control panel menus.
2. Press the  Down button several times until **Reset Menu** appears on the LCD panel, then press the  Enter button.
3. Press the  Down button several times until **Reset** to display.
4. Press the  Enter button. Printing is canceled. The printer is ready to receive a new print job.

550-Sheet Universal Paper Cassette Unit

Note:

You can install up to two units.

For details about the paper types and sizes that you can use with the optional paper cassette unit, see "550-Sheet Universal Paper Cassette Unit" on page 39. For specifications, see "550-Sheet Universal Paper Cassette Unit" on page 283.

Handling precautions

Always pay attention to the following handling precautions before installing the option.

The printer weighs about 22 kg (48.5 lb). One person should never attempt to lift or carry it alone. Two people should carry the printer, lifting it from the positions shown below.

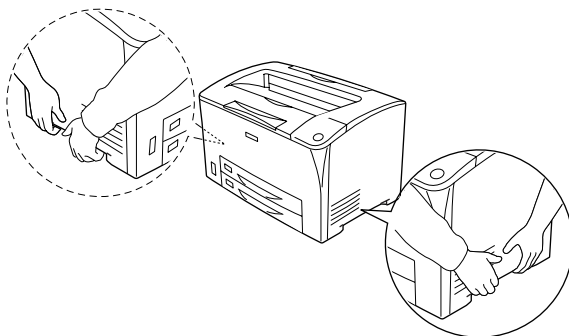



Warning:

If you lift the printer incorrectly, you could drop it and cause injury.

Installing the 550-Sheet Universal Paper Cassette Unit

Follow these steps to install the optional 550-Sheet Universal Paper Cassette Unit.

1. Turn the printer off and unplug the power cord and interface cable.

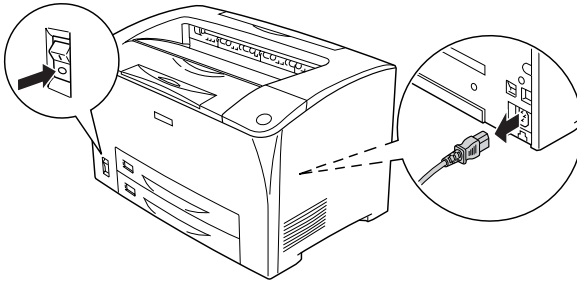

Caution:

Make sure to unplug the power cord from the printer to prevent getting an electrical shock.

2. Place the printer onto the 550-Sheet Universal Paper Cassette Unit. Align each of the printer's corners with those of the unit, then lower the printer until it rests securely on the unit.

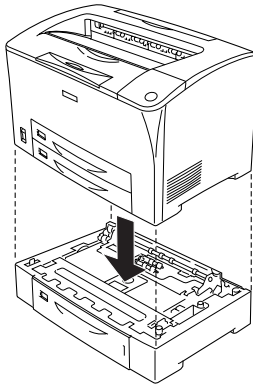

Note:

- ❑ *The printer should be carried by at least two people, holding the printer with their hands in the indicated positions.*
- ❑ *When you install two optional paper cassette units, put one unit upon the other unit in order, then put the printer on top of them.*

3. Pull out the MP tray and lower paper cassette from the printer, and then pull out the optional lower paper cassette from the unit. Then, secure the printer to the unit with the four fittings that are provided. Install two of the four fittings on both sides of the inside of the printer.

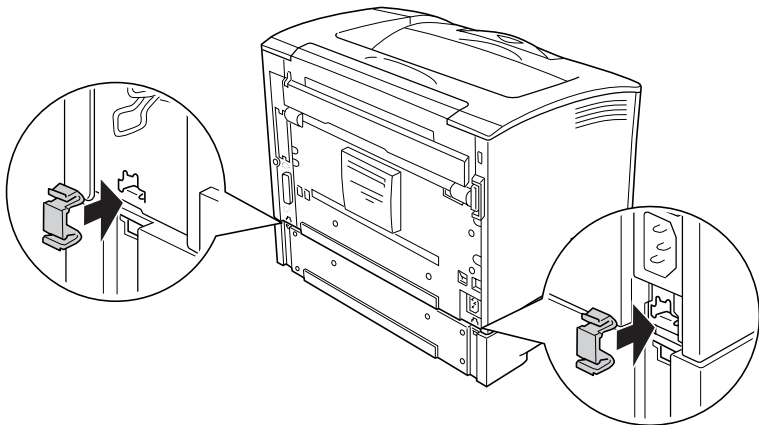
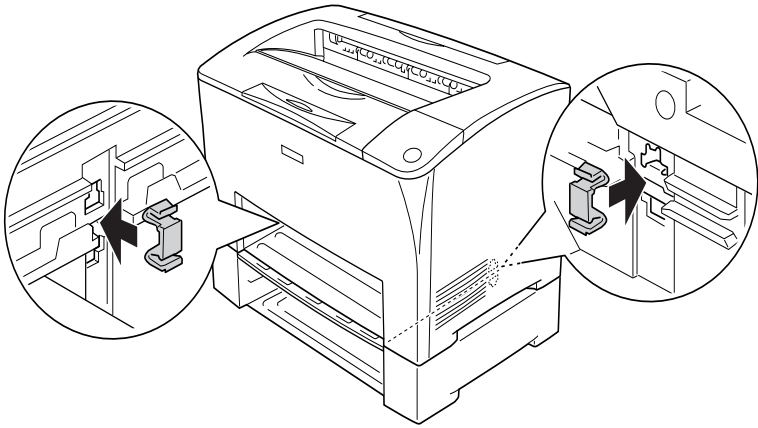

4. Remove the protective materials from the paper cassette and load the paper.

5. Reconnect the interface cable and power cord, then turn the printer on.
6. To confirm that the option is installed correctly, print a Status Sheet. See "Printing a Status Sheet" on page 245.

Removing the 550-Sheet Universal Paper Cassette Unit

Perform the installation procedure in reverse.

Duplex Unit

For the paper types and sizes that you can use with the Duplex Unit, see "Paper Sources" on page 38 or "Printing on Special Media" on page 50. For specifications, see "Duplex Unit" on page 284.

Installing the Duplex Unit

Follow these steps to install the optional Duplex Unit.

1. Turn the printer off and unplug the power cord and interface cable.

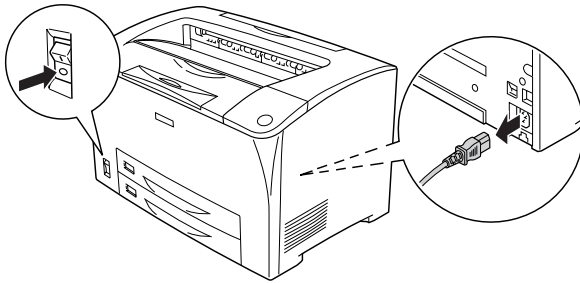

Caution:

Make sure to unplug the power cord from the printer to prevent getting an electrical shock.

2. Pinch the three hooks on the upper option cover to remove it from Cover B. Then pull back on the tabs on the lower option cover to remove it.

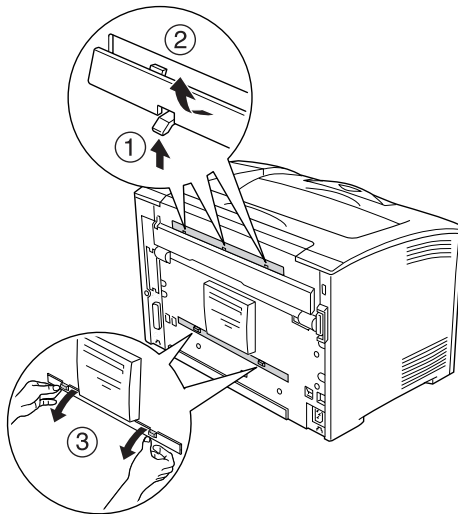

3. Install the Duplex Unit as shown below. Make sure that the unit hooks onto the printer's tabs and the duplex connector goes into the slot.

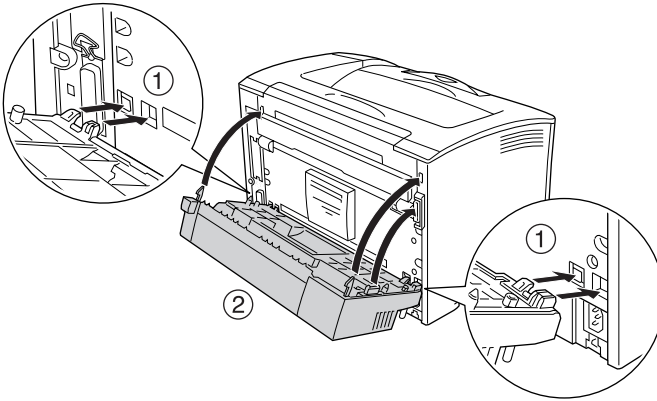

4. Secure the unit with the two screws provided.

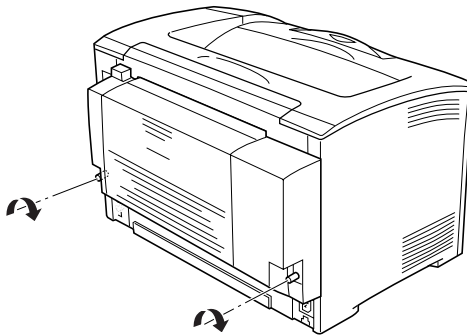

5. Reconnect the interface cable and power cord, then turn the printer on.
6. To confirm that the option is installed correctly, print a Status Sheet. See "Printing a Status Sheet" on page 245.

See "Printing with the Duplex Unit" on page 65 for information about duplex printing.

Removing the Duplex Unit

Follow these steps to remove the optional Duplex Unit.

1. Turn the printer off and unplug the power cord and interface cable.
2. Loosen the two screws on the lower sides of the Duplex Unit.

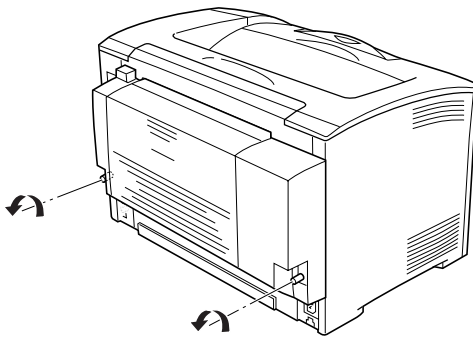

3. Press the unlock button to unlock the hooks, then remove the unit from the printer.

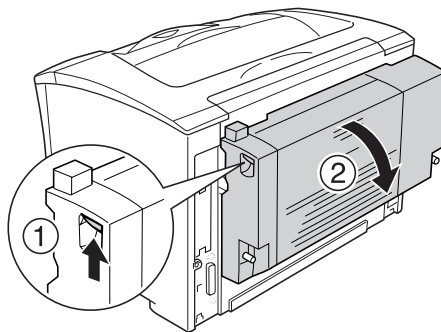

4. Attach the upper option cover and lower option cover.
5. Reconnect the interface cable and power cord, then turn the printer on.

Memory Module

By installing a Dual In-line Memory Module (DIMM), you can increase printer memory up to 320 MB (printer standard 64 MB plus optional 64, 128, 256 MB). You may want to add additional memory if you are having difficulty printing complex graphics.

Installing a memory module

Follow these steps to install an optional memory module.



Warning:

Be careful when working inside the printer as some components are sharp and may cause injury.



Caution:

Before you install a memory module, be sure to discharge any static electricity by touching a grounded piece of metal. Otherwise, you may damage static-sensitive components.

1. Turn the printer off and unplug the power cord and interface cable.

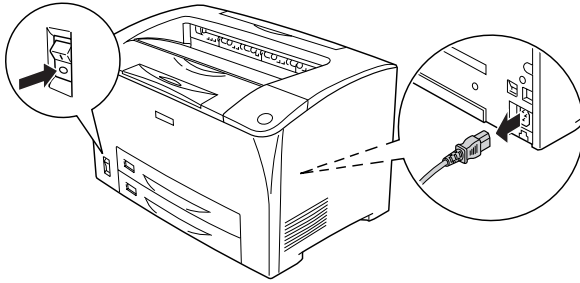

2. Remove the cover on the printer's right side by removing the screw on the back of the printer and sliding the cover backward.

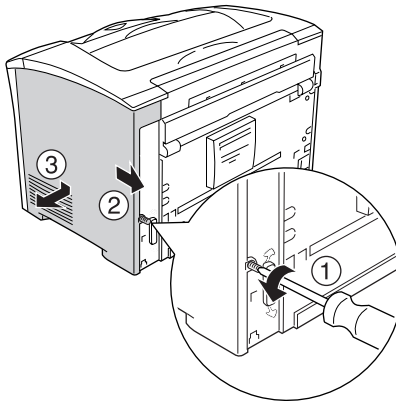

3. Loosen the two screws using a screwdriver. Then hold the tab on the top of the shield cover and remove the cover.

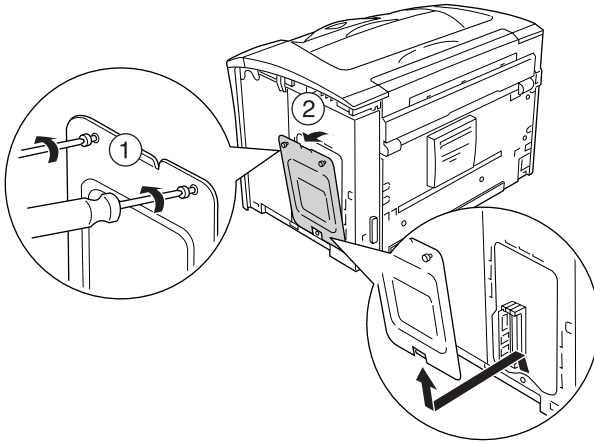

4. Identify the RAM slot.

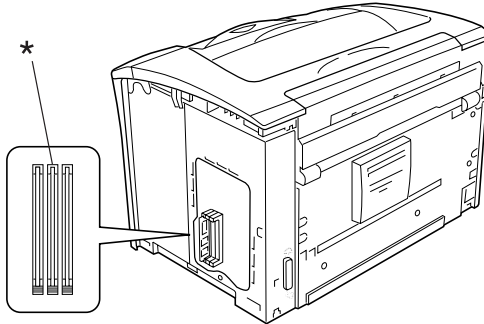

* RAM slot (gray)

5. Insert the memory module into slot until the clip lock onto the memory module. Make sure that the left slot (white) has a module at all times.

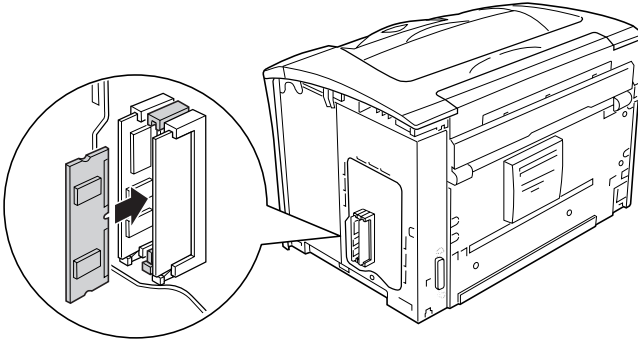

Caution:

- ❑ *Do not force the memory module into the slot.*
- ❑ *Be sure to insert the memory module facing the correct way.*
- ❑ *You should not remove any modules from the circuit board. Otherwise, the printer will not work.*

6. Reattach the shield cover with two screws as shown below.

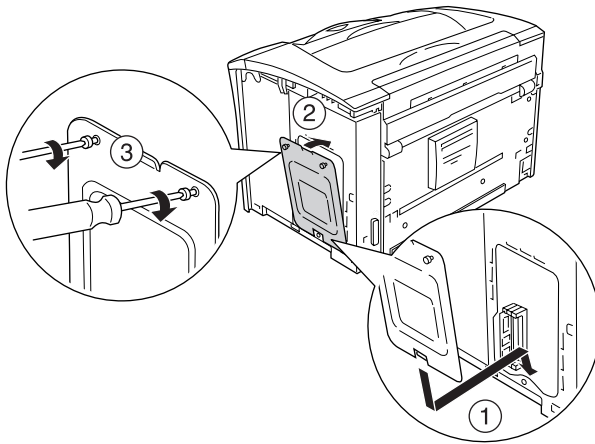

7. Reattach the right side cover to the printer as shown below. Then, tighten the screw on the back of the printer.

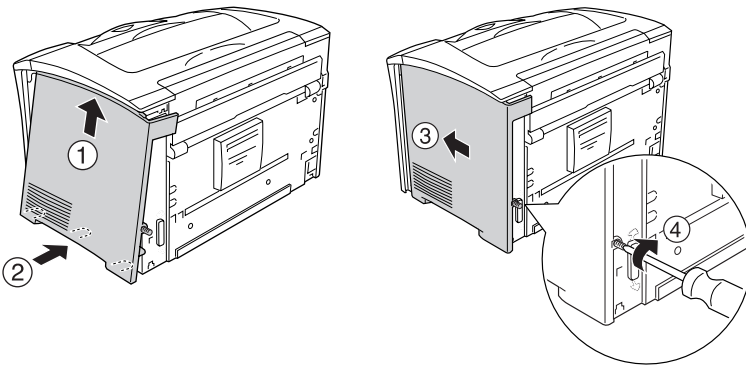

Warning:

Tighten the screw firmly to prevent the printer's right side cover from the falling off when moving the printer.

8. Reconnect the interface cable and power cord and turn the printer on.
9. To confirm that the option is installed correctly, print a status sheet. See "Printing a Status Sheet" on page 245.

Removing a memory module

Perform the installation procedure in reverse.

When removing a memory module from its slot, press the clip and pull out the memory module as shown below.

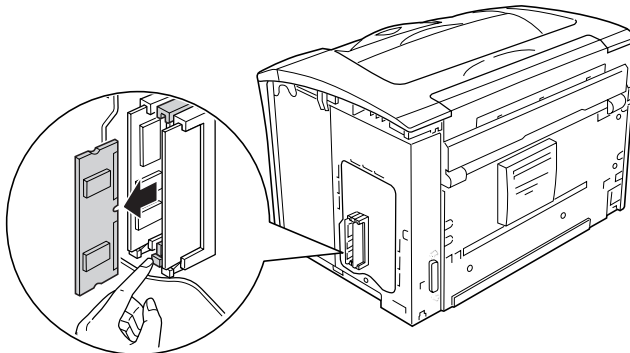

Note:

If the optional memory module is hard to remove, temporarily remove the other memory module from slot A so it is easier to reach the optional memory module to remove it. After removing the module, be sure to replace the other memory module.

Interface Card

Your printer comes with a Type B interface slot. Various optional interface cards are available to expand your printer's interface options.

Installing an interface card

Follow these steps to install an optional interface card.



Caution:

Before you install the interface card, be sure to discharge any static electricity by touching a grounded piece of metal. Otherwise, you may damage static-sensitive components.

1. Turn the printer off and unplug the power cord and interface cable.

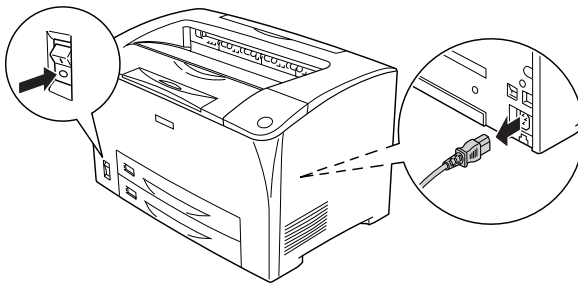

2. Remove the screws and the Type B interface card slot cover as shown below.

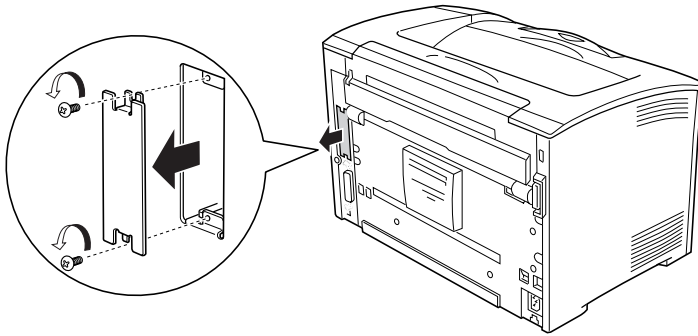

Warning:

Removing screws and covers that are not described in the following instructions will expose high voltage areas.

Note:

Keep the slot cover in a safe place. You will need to reattach it if you remove the interface card later.

3. Slide and push the interface card into the slot firmly, then fasten the screw as shown below.

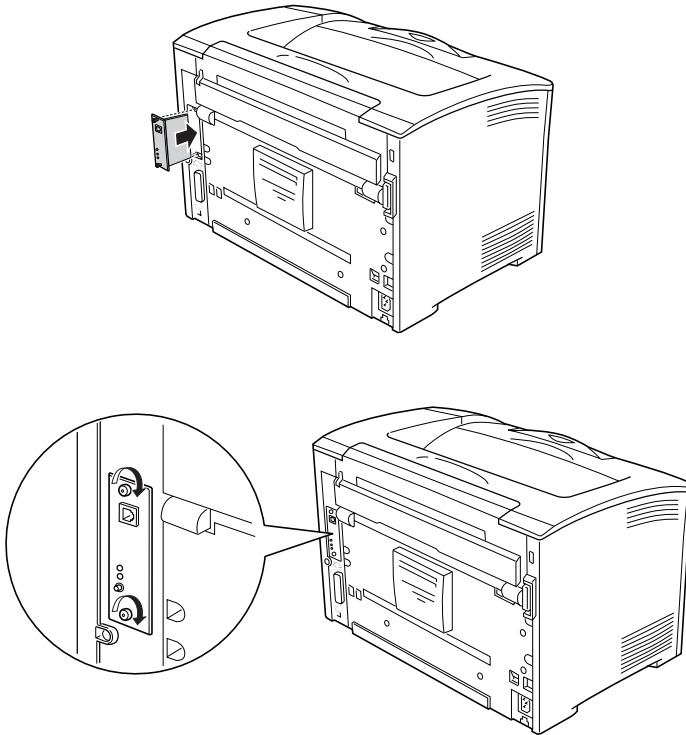

4. Reconnect the interface cable and power cord and turn the printer on.
5. To confirm that the option is installed correctly, print a status sheet. See "Printing a Status Sheet" on page 245.

Removing an interface card



Caution:

Before you remove an interface card, be sure to discharge any static electricity by touching a grounded piece of metal.

Otherwise, you may damage static-sensitive components.

Perform the installation procedure in reverse.

Replacing Consumable Products

Replacement Messages

When you see the following messages on the LCD panel or the window of EPSON Status Monitor, replace the appropriate consumable products. You can continue to print for a short time after a message appears, but EPSON recommends early replacement to maintain print quality and extend the life of your printer.

Control panel message	Description
Toner Low	The amount of remaining toner in the imaging cartridge is low.
Worn Fuser	The fuser unit has reached the end of its service life.

Note:

To clear these messages, select Clear All Warnings in Reset Menu.

When the Toner out setting in the Setup Menu on the control panel is set to Stop, the following occurs.

If you continue to use the printer without replacing consumable products and a consumable product reaches the end of its service life, the printer stops printing and displays the following messages on the LCD panel or the window of EPSON Status Monitor.

Control panel message	Description
Replace Toner	The imaging cartridge is empty.

Imaging Cartridge

Handling precautions

Always observe the following handling precautions when replacing imaging cartridges.

- ❑ When handling imaging cartridges, always place them on a clean smooth surface.
- ❑ Do not install used imaging cartridges into the printer.
- ❑ If you have moved an imaging cartridge from a cool to a warm environment, wait for at least one hour before installing it to prevent damage from condensation.
- ❑ Do not open the drum's protective cover and avoid exposing an imaging cartridge to room light any longer than necessary. Overexposing the cartridge may cause abnormally dark or light areas to appear on the printer page and reduce the life of the cartridge.

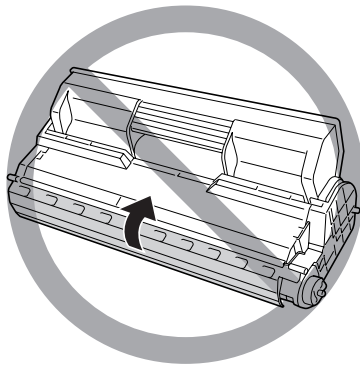



Warning:

- ❑ *Do not touch the toner. Keep the toner away from your eyes. If toner gets on your skin or clothes, wash it off with soap and water immediately.*

- ❑ *Keep the consumable products out of the reach of children.*

- ❑ *Do not dispose of the consumable products in fire, as they may explode and cause injury. Dispose of them according to local regulations.*

Replacing an imaging cartridge

Follow these steps to replace an imaging cartridge.

1. Open Cover A slowly.

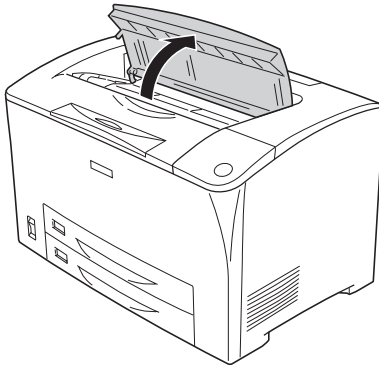

2. Hold the handle of the imaging cartridge and pull out from the printer.

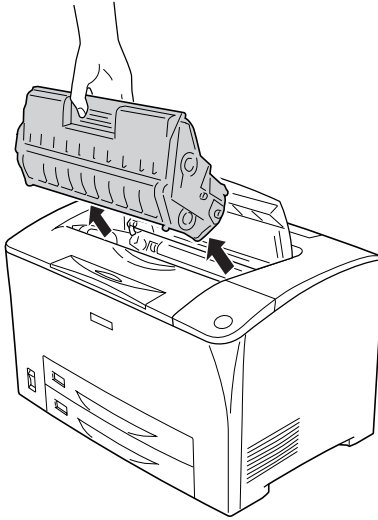

3. Take the new imaging cartridge out of its package and gently shake the imaging cartridge as shown below.

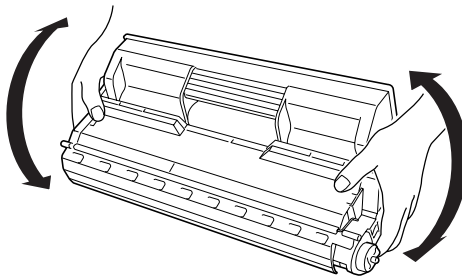

4. Put the new imaging cartridge on the flat surface and pull out the protective cartridge seal as shown below.

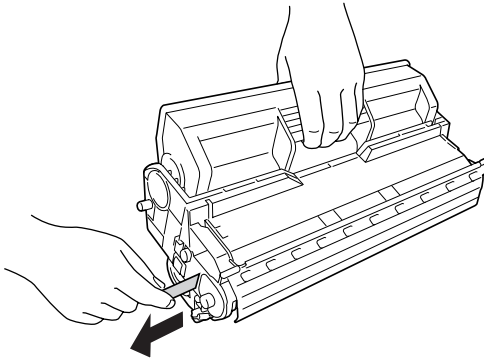

5. Insert the new imaging cartridge all the way until it stops.

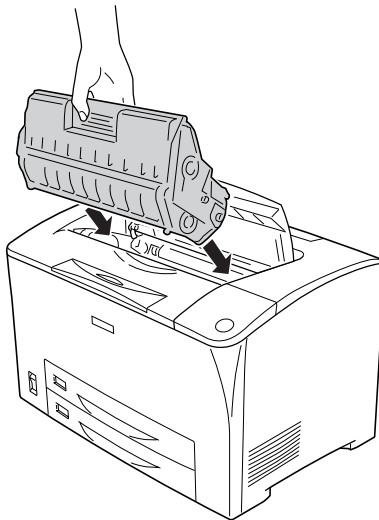

Note:

Insert the cartridge with the arrow mark on the top of the imaging cartridge facing toward Cover A.

6. Close Cover A until it clicks shut.

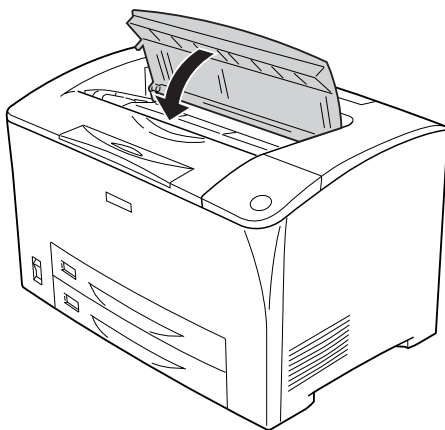

Note for windows users:

If EPSON Status Monitor is installed, the information about the amount of toner remaining on the Basic Setting screen may not be updated. In that case, press the Get Information Now button on the Consumable Info Settings dialog box to update the information. You can open the Consumable Info Settings dialog box by clicking the Consumable Info Settings button on the Optional Settings tab.

Fuser Unit

Handling precautions

Always observe the following handling precautions when replacing the consumable products.

Do not touch the surface of the consumable product. Doing so may impair print quality.



Warning:

- ❑ *The fuser unit can be very hot if the printer has been in use. Turn the printer off and wait for 40 minutes until the temperature has subsided before replacing the fuser unit.*

- ❑ *Do not dispose of the used consumable products in fire, as it may explode and cause injury. Dispose of it according to local regulations.*

- ❑ *Keep the consumable products out of the reach of children.*

Replacing the fuser unit

Follow the steps below to replace the fuser unit.

1. Turn off the printer and unplug the power cord and the interface cable.

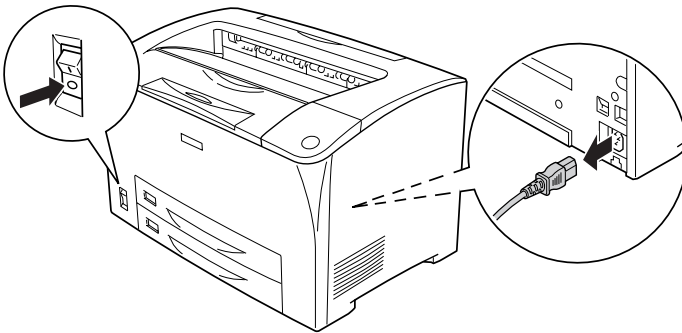

Warning:

If the printer has been in use, wait at least 40 minutes until the fuser cools down before replacing it.

2. Open cover B.

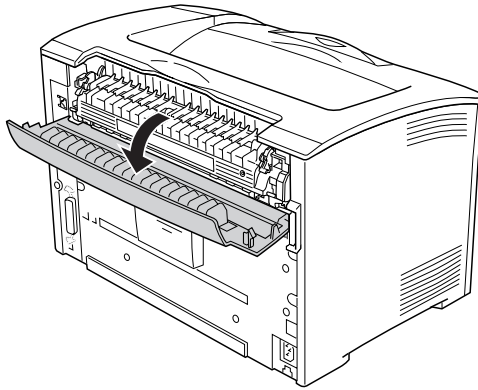

3. Pull down the two levers at either side of the fuser unit.

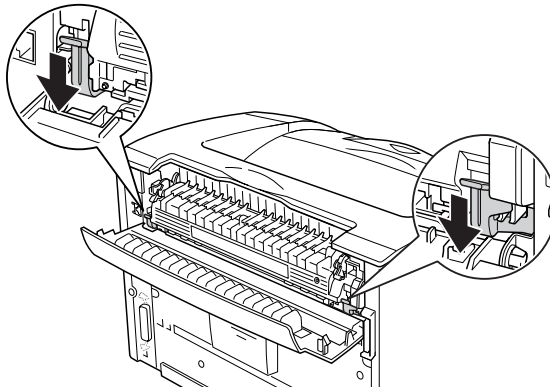

4. Remove the fuser unit slowly.

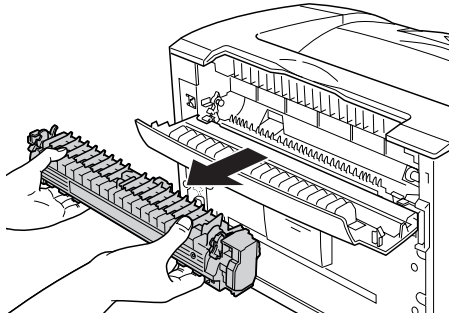

5. Slowly insert the new fuser unit.

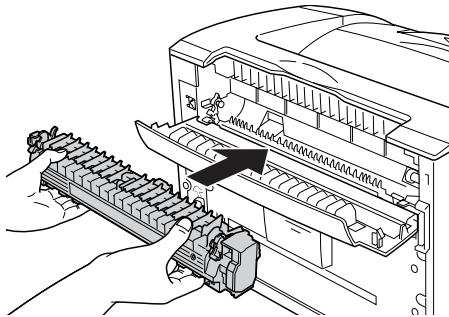

6. Make sure that the two levers at either side of the fuser unit are moved up.

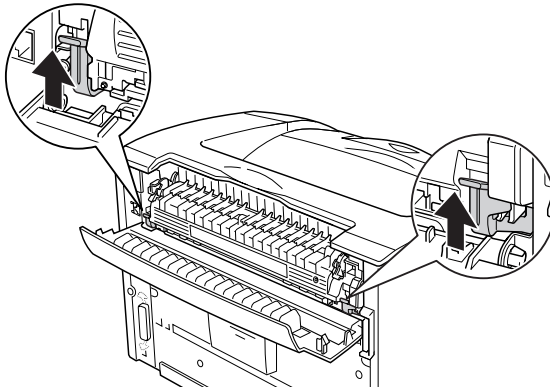

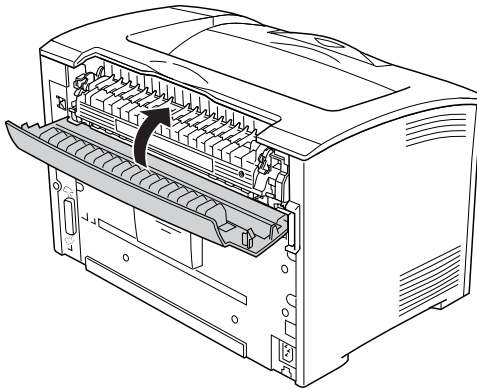

7. Close cover B.

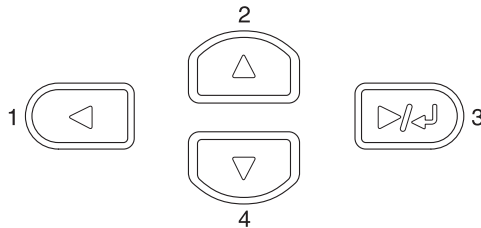

8. Reconnect the interface cable and power cord, and then turn on the printer.

9. When the printer's Ready light is on, press the  Enter button to access the control panel menus.



10. Press the ▲ Up or ▼ Down button several times until Reset Menu appears on the control panel, and then press the  Enter button.
11. Press the ▼ Down button to display Reset Fuser Counter, and then press the  Enter button.

Cleaning and Transporting the Printer

Cleaning the Printer

The printer needs only minimal cleaning. If the printer's outer case is dirty or dusty, turn off the printer and clean it with a soft, clean cloth moistened with a mild detergent.

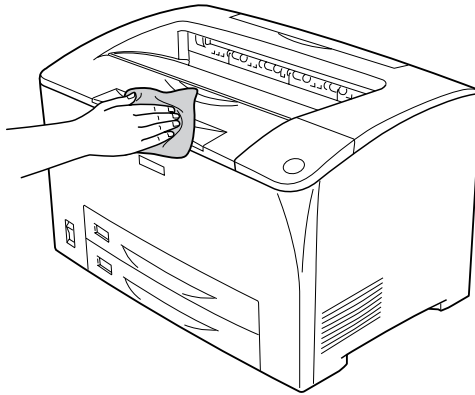

Caution:

Never use alcohol or paint thinner to clean the printer cover; these chemicals can damage the components and the case. Be careful not to get water onto the printer mechanism or any electrical components.

Cleaning the pickup roller

If the paper jam occurs frequently, wipe the pickup roller with a clean dampened cloth. Follow the steps below.

1. Turn the printer off and open Cover A slowly.

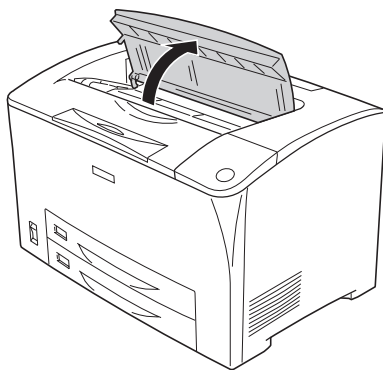

2. Hold the handle of the imaging cartridge and pull out.

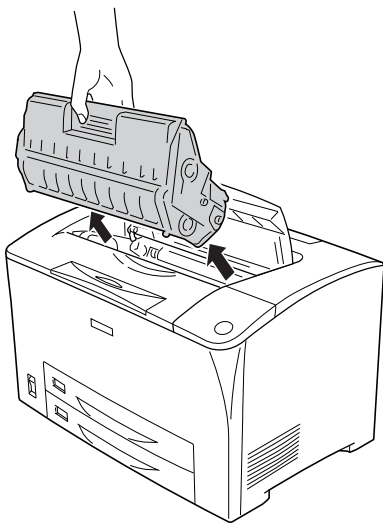

Note:

Place the cartridge on a clean, flat surface.

3. Remove the two pick up rollers by bending their tabs slightly outwards while sliding them off the spindles.

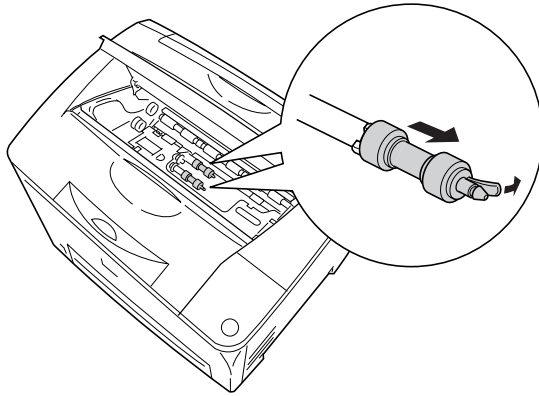

4. With a clean damp cloth, wipe the pickup roller's rubber parts.

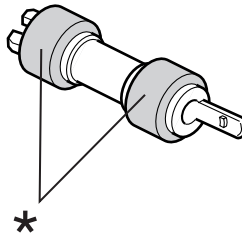

* rubber parts

5. Reattach the pickup rollers as shown below. Then, fit the hook in the concave part of the shafts to fix them.

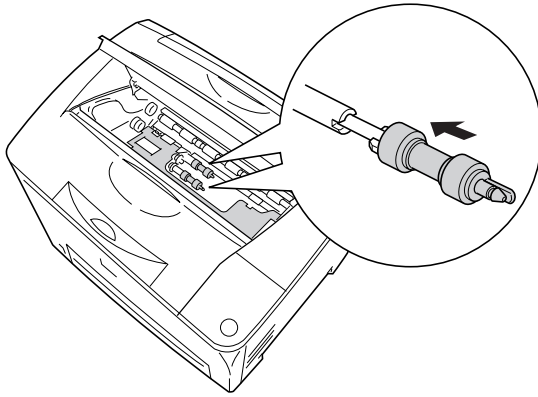

Note:

Fit the convex parts of the pickup rollers in the concave parts of the shaft.

6. Reinstall the imaging cartridge.

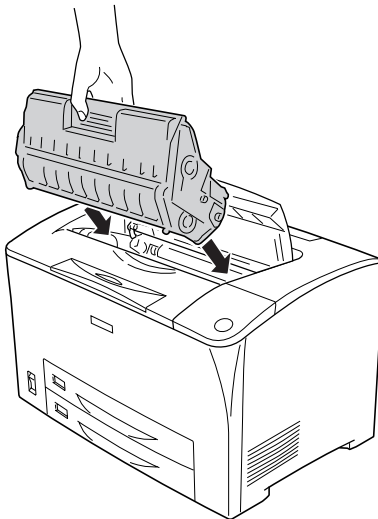

7. Close Cover A until it clicks shut.

Transporting the Printer

For long distances

If you need to transport your printer for long distances, carefully repack it using the original box and packing materials.

Follow these steps to repack your printer.

1. Turn off the printer.
2. Remove the following items:
 - Imaging cartridge
 - Power cord
 - Interface cables
 - Loaded paper
3. Remove all installed options. For information on removing options, see the section under Installing Options.
4. Attach the protective materials onto the printer, then repack the printer in its original box.

For short distances

Always pay attention to the following handling precautions when you need to move the printer for a short distance:

- ❑ If you are moving the printer on its own, two people should lift and carry the printer.

Moving the printer

Follow these steps to move the printer for a short distance.

1. Turn off the printer and remove the following items:
 - ❑ Power cord
 - ❑ Interface cable
2. Be sure to lift the printer by the correct positions as shown below.

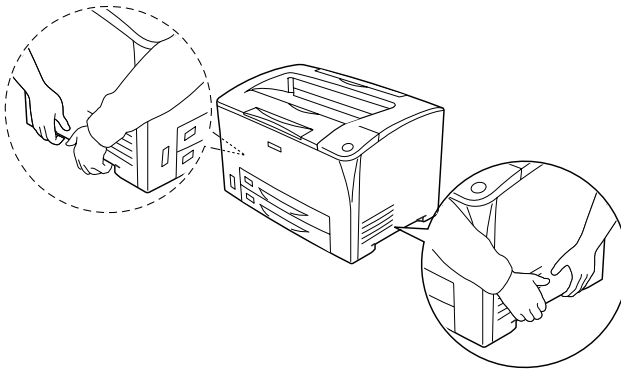

3. When moving the printer, always keep it horizontal.

Moving the printer together with an optional lower paper cassette installed

Follow these steps to move the printer together with the optional 550-Sheet Universal Paper Cassette Unit:

1. Turn off the printer and remove the following items.

- ❑ Power cord
 - ❑ Interface cable
2. Lift the printer together with the optional unit.



Caution:

Do not move the printer on angled or uneven surfaces.

Finding a place for the printer

When relocating the printer, always choose a location that has adequate space for easy operation and maintenance. Use the following illustration as a guide for the amount of space required around the printer to ensure smooth operation. Dimensions shown in the illustrations below are in millimeters.

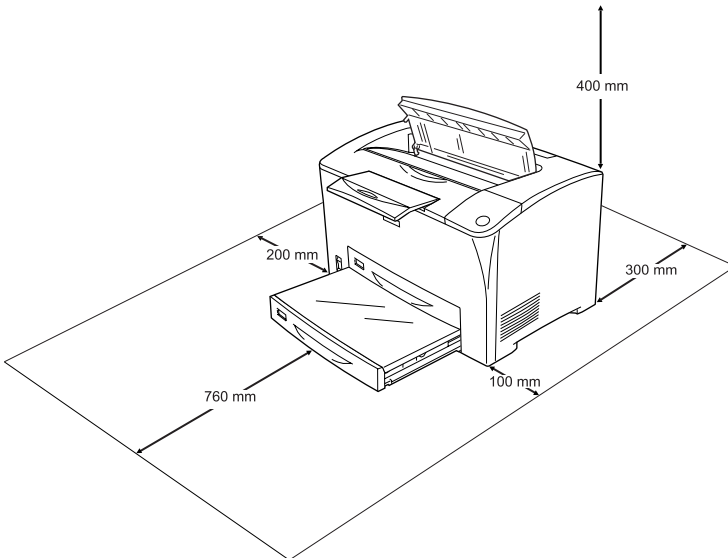

To install and use any of the following options, you will need the indicated amount of additional space.

The 550-Sheet Universal Paper Cassette Unit adds 95 mm (3.7 in.) to the bottom of the printer. When two optional paper cassette units are installed, the printer requires 190 mm (7.4 in.) more space beneath the printer.

The Duplex Unit adds 68.5 mm (2.7 in.) to the back of the printer.

In addition to space consideration, always heed the following precautions when finding a place to locate the printer:

- ❑ Place the printer where you can easily unplug the power cord.
- ❑ Keep the entire computer and printer system away from potential sources of interference, such as loudspeakers or the base units of cordless telephones.
- ❑ Avoid using an electrical outlet that is controlled by wall switches or automatic timers. Accidental disruption of power can erase valuable information in your computer's and printer's memory.



Caution:

- ❑ *Leave adequate room around the printer to allow for sufficient ventilation.*
- ❑ *Avoid locations that are subject to direct sunlight, excessive heat, moisture, or dust.*
- ❑ *Avoid using outlets that other appliances are plugged into.*
- ❑ *Use a grounded outlet that matches the printer's power plug. Do not use an adapter plug.*
- ❑ *Only use an outlet that meets the power requirements for this printer.*

Troubleshooting

Clearing Jammed Paper

If paper becomes jammed in the printer, the printer's LCD panel and EPSON Status Monitor provide alert messages.

Precautions for clearing jammed paper

Be sure to observe the following points when you clear jammed paper.

- ❑ Do not remove jammed paper by force. Torn paper can be difficult to remove and might cause other paper jams. Pull it gently in order to avoid tearing.
- ❑ Always try to remove jammed paper with both hands to avoid tearing it.
- ❑ If jammed paper is torn and remains in the printer, or if paper is jammed in a place not mentioned in this section, contact your dealer.
- ❑ Make sure that the paper type that is loaded is the same as the Paper Type setting in the printer driver.



Warning:

Unless specifically instructed in this guide, be careful not to touch the fuser, which is marked CAUTION HOT SURFACE and CAUTION HIGH TEMPERATURE, or the surrounding areas. If the printer has been in use, the fuser and the surrounding areas may be very hot. If you must touch one of these areas, wait 40 minutes to allow the heat to subside before doing so.

Jam A (Cover A)

When a paper jam occurs in the location shown in the illustration below, the Jam A message appears on the printer's LCD panel.

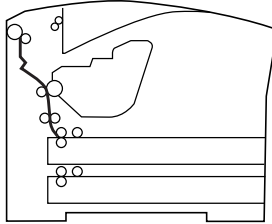

Follow these steps to clear paper jams from Cover A.

1. Open Cover A.

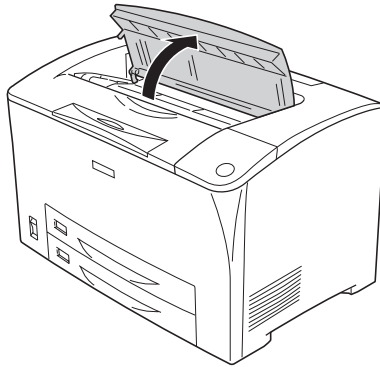

2. Hold the handle of the imaging cartridge and pull out.

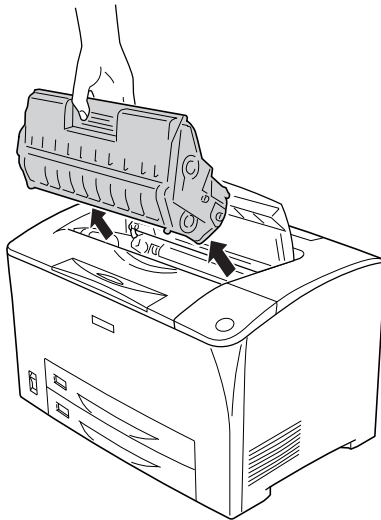

Note:

Place the cartridge on a clean, flat surface.

3. Spin the green part on the pickup roller to bring out jammed paper.

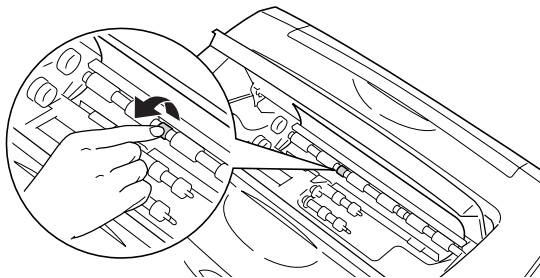

Note:

Only touch the green part of the pickup roller. Touching any other parts may cause a paper jam.

4. Gently pull out any sheets that have fed part way into the printer.

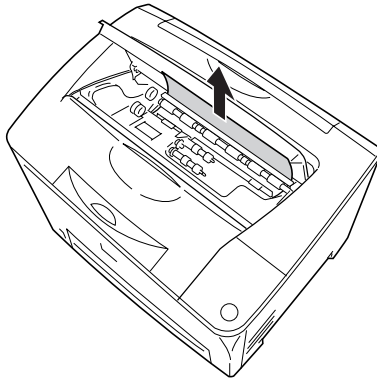

5. Reinstall the imaging cartridge.

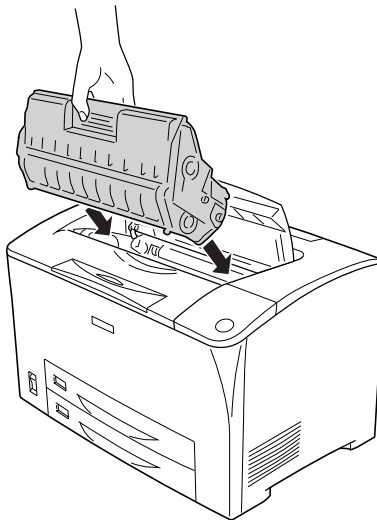

Note:

Insert the cartridge with the arrow mark on the top of the imaging cartridge facing toward Cover A.

6. Close Cover A until it clicks shut.

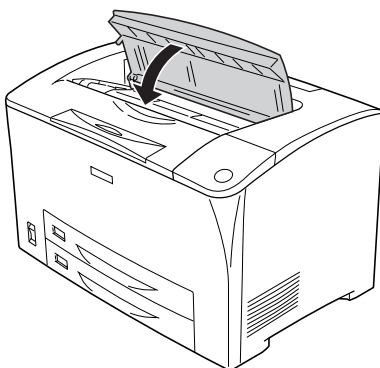

Jam A B (Cover A or B)

When a paper jam occurs in the location shown in the illustration below, the **Jam A B** message appears on the printer's LCD panel.

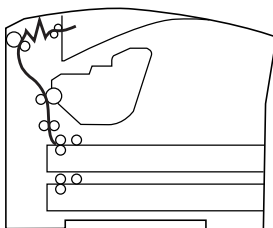

Follow these steps to clear paper jams from Cover A or B.



Warning:

*Unless specifically instructed in this guide, be careful not to touch the fuser, which is marked **CAUTION HOT SURFACE** and **CAUTION HIGH TEMPERATURE**, or the surrounding areas. If the printer has been in use, the fuser and the surrounding areas may be very hot. If you must touch one of these areas, wait 40 minutes to allow the heat to subside before doing so.*

1. Open Cover A.

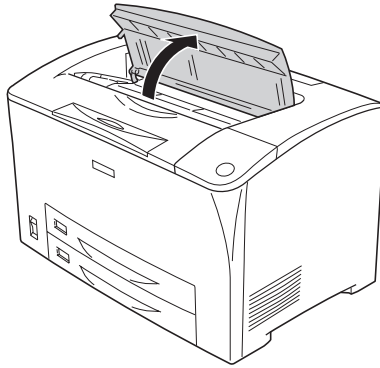

2. Hold the handle of the imaging cartridge and pull out.

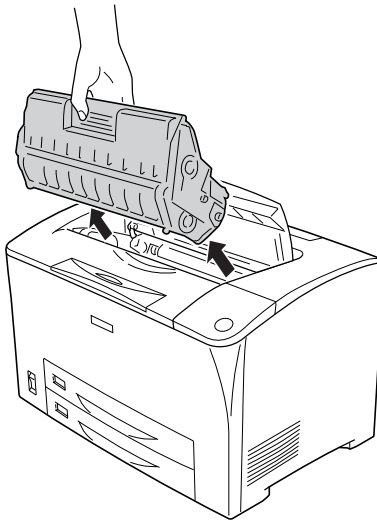

Note:

Place the cartridge on a clean, flat surface.

3. If there is any jammed paper, remove it gently with both hands. Be careful not to tear the jammed paper.

Note:

When jammed paper cannot be removed easily, turn the roller to take tension off the paper, then pull it straight out.

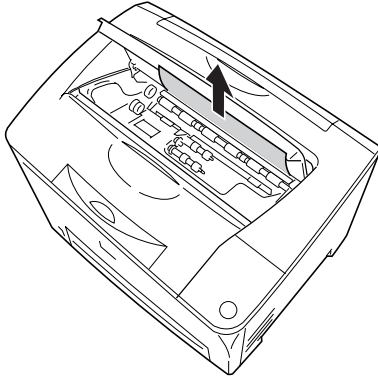

4. Open Cover B.

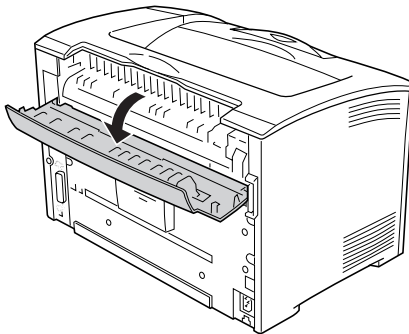

Note:

When the optional Duplex Unit is installed, open the Duplex Unit's cover before opening Cover B.

5. Open the paper holder by pulling down on the lever on which a green label is attached as shown below.

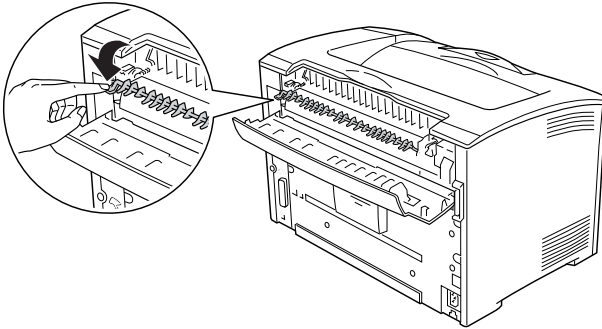

Warning:

Be careful not to touch the rollers in the fuser unit, they may be very hot.

6. If there is any jammed paper, remove it gently. Be careful not to tear the jammed paper.

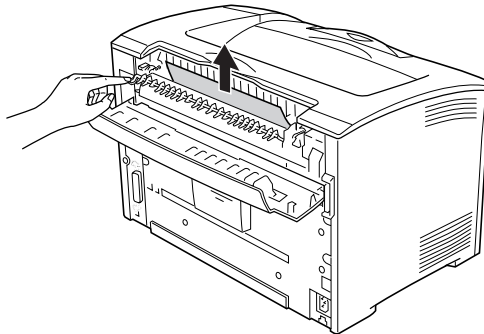

7. Close the paper holder and close Cover B.

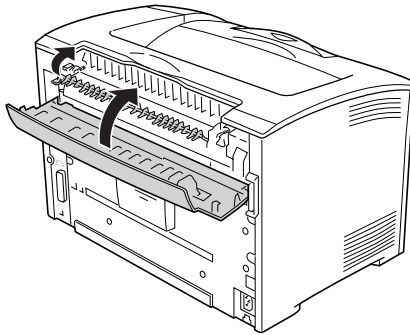

Note:

If you installed the Duplex Unit, close the Duplex Unit's cover after closing Cover B.

8. Reinstall the imaging cartridge.

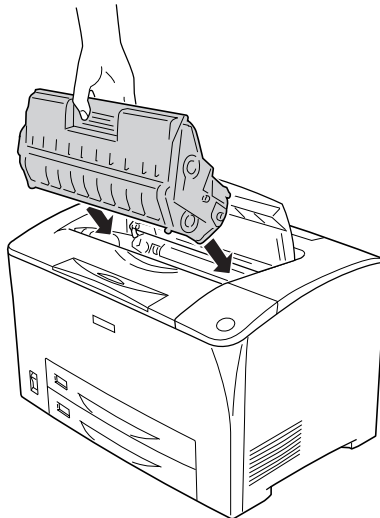

Note:

Insert the cartridge with the arrow mark on the top of the imaging cartridge facing toward Cover A.

9. Close Cover A until it clicks shut.

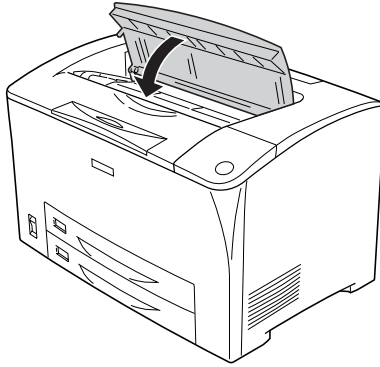

Jam DM (Cover DM)

When a paper jam occurs in the location shown in the illustration below, the Jam DM message appears on the printer's LCD panel.

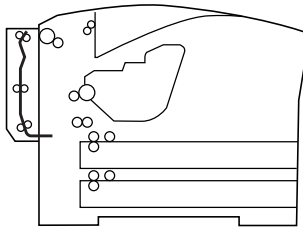

Follow these steps to clear paper jams in the Duplex Unit's cover.

1. Press the unlock button to unlock the hooks. Then open the cover of the Duplex Unit.

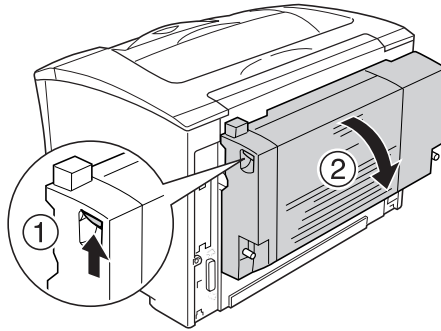

2. Gently remove the jammed paper inside the cover. Be careful not to tear the paper.

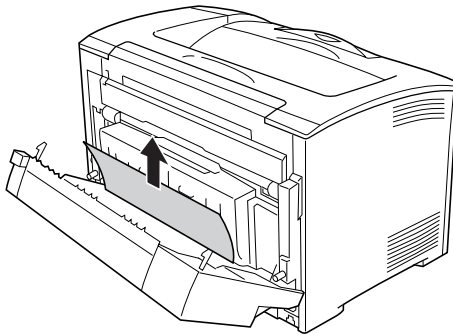

Note:

- ❑ If paper is torn, be sure to remove all torn pieces.
- ❑ When you cannot remove jammed paper by this procedure, open Cover A or Cover B and remove the jammed paper as described in "Jam A B (Cover A or B)" on page 235.

3. Close the Duplex Unit's cover.

Note:

When the error is not cleared after doing the procedure above, remove the Duplex Unit from the printer and check if the paper jam occurs at the opening on the lower part of the printer's rear.

When the paper jam is cleared completely and Cover DM is closed, the jammed page's print data is automatically reprinted.

Jam MP A, Jam C1 A, Jam C2 A, Jam C3 A (All paper cassettes and Cover A)

When a paper jam occurs in the location shown in the illustration below, the Jam MP A, Jam C1 A, Jam C2 A, or Jam C3 A message appears on the printer's LCD panel.

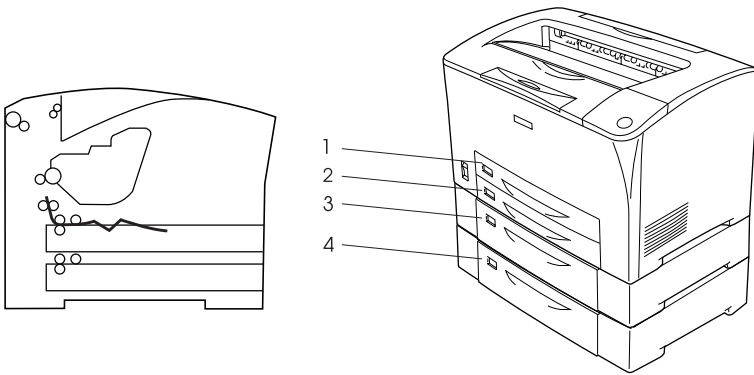

1. MP Tray
2. lower paper cassette 1 (C1)
3. lower paper cassette 2 (C2)
4. lower paper cassette 3 (C3)

Follow these steps to clear paper jams in paper cassettes.

1. Pull out the paper cassette from the printer.

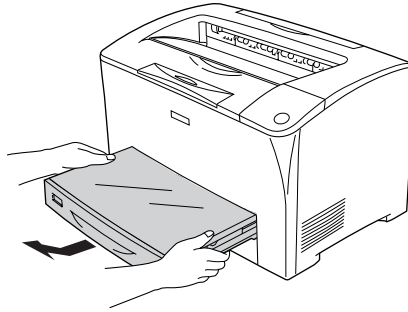

2. Remove the paper cassette's cover and discard any crumpled paper. Then, reattach the cover.

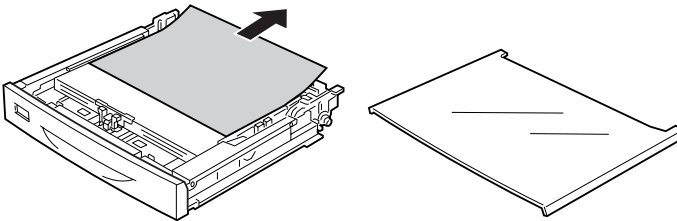

3. Gently remove the jammed paper with both hands. Be careful not to tear the jammed paper.

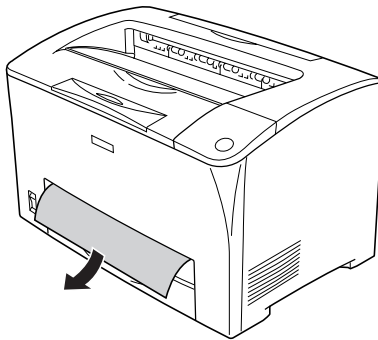

Note:

Confirm that the jammed paper is not still deep inside the printer.

4. Reinsert the paper cassette.

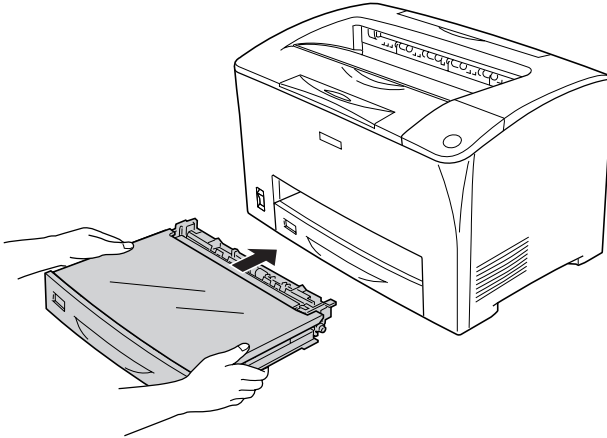

5. Open Cover A and then close Cover A again.

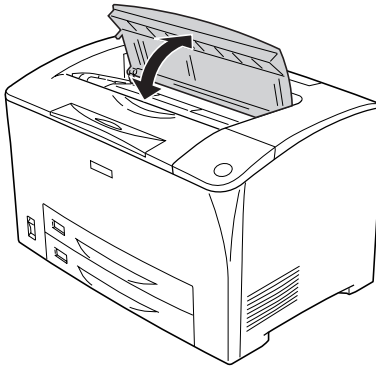

Note:

After opening and closing Cover A, the error message is cleared.

Printing a Status Sheet

To confirm the current status of the printer, and that the options are installed correctly, print a status sheet using the printer's control panel or the printer driver.

To print a status sheet from the printer's control panel, see "Printing a Status Sheet" on page 192.

To print a status sheet from the printer driver, see "Printing a status sheet" on page 85.

Operational Problems

The Ready light does not turn on

Cause	What to do
The power cord may not be properly plugged into the electrical outlet.	Turn off the printer, check the power cord connections between the printer and the electrical outlet, then turn the printer back on.
The electrical outlet may be controlled by an outside switch or an automatic timer.	Make sure that the switch is turned on or plug another electrical device into the outlet to check whether the outlet is operating properly.

The printer does not print (Ready light off)

Cause	What to do
The printer is offline.	Press the  Start/Stop button once to switch the printer to ready status.

Some error may have occurred.	Check the LCD panel to see if an error message appears.
-------------------------------	---

The Ready light is on but nothing prints

Cause	What to do
Your computer may not be properly connected to the printer.	Perform the procedure illustrated in the <i>Setup Guide</i> .
The interface cable may not be plugged in securely.	Check both ends of the interface cable between the printer and the computer. If you are using the parallel interface, be sure to secure the connector using the wire retaining clips.
You may not be using the correct interface cable.	If you are using the parallel interface, make sure that the cable is a double-shielded, twisted-pair interface cable no more than six feet in length. If you are using the USB interface, use a Revision 2.0 cable.
The printer port is not set correctly in the printer driver.	Make sure that the printer port is set correctly in the printer driver.
Your application software is not properly set up for your printer.	Make sure that the printer is selected in your application software.
Your computer system's memory is too small to handle the volume of data in your document.	Try reducing the image resolution of your document in the application software, or install more memory in your computer if you can.

The optional product is not available

Cause	What to do
--------------	-------------------

<p>EPSON Status Monitor is not installed.</p>	<p>You have to install EPSON Status Monitor, or make settings manually in the printer driver. See "Installing EPSON Status Monitor" on page 86 or "Making Optional Settings" on page 85.</p>
---	--

The Properties dialog box does not appear or it takes too much time to open it (For Windows Only)

Cause	What to do
<p>Bidirectional communication is disabled.</p>	<p>Make sure that the printer is on and connected with the appropriate cable. Select the Enable bidirectional support check box on the Ports menu of the Properties dialog box (for Windows XP, 2000, or Server 2003) or in the printer driver (for Windows Me or 98). Then select the Do not display consumables information check box in the Consumables Info Settings dialog box.</p>

The amount of a toner remaining is not updated (For Windows users only)

Cause	What to do
<p>The interval between updating information for the consumables is too long.</p>	<p>Press the Get Information Now button on the Consumable Info Settings dialog box. You can also change the interval for updating information about the consumables on the Consumable Info Settings dialog box.</p>

Printout Problems

The font cannot be printed

Cause	What to do
You may use the printer fonts substituted for specified TrueType fonts.	In the printer driver, choose the Print TrueType fonts as bitmap button in the Extended Settings dialog box.
The selected font is not supported by your printer.	Make sure that you have installed the correct font. See "Available fonts" on page 309 for more information.

Printout is garbled

Cause	What to do
The interface cable may not be plugged in securely.	Make sure that both ends of the interface cable are plugged in securely.
You may not be using the correct interface cable.	If you are using the parallel interface, make sure that the cable is a double-shielded, twisted-pair interface cable no more than six feet in length. If you are using the USB interface, use a Revision 2.0 cable.
The emulation setting for the port may not be correct.	Specify the emulation mode by using the printer's control panel menus. See "Emulation Menu" on page 155.

Note:

If a status sheet does not print correctly, your printer may be damaged. Contact your dealer or a qualified service representative.

The printout position is not correct

Cause	What to do
The page length and margins may be set incorrectly in your application.	Make sure that you are using the correct page length and margin settings in your application.
The Paper Size setting may be incorrect.	Make sure the correct paper size is set in the Tray Menu on the control panel.
MP Tray Size setting may be incorrect.	When loading paper for which the size is not specified with Auto setting, specify the correct paper size on the MP Tray Size setting in the Tray Menu on the control panel.

Graphics do not print correctly

Cause	What to do
The printer emulation setting in your application may be incorrect.	Make sure that your application is set for the printer emulation you are using. For example, if you are using the LJ4 emulation mode, make sure that your application is set to use a LaserJet 4 printer.
You may need more memory.	Graphics require large amounts of memory. Install an appropriate memory module. See "Memory Module" on page 202.

Print Quality Problems

The background is dark or dirty

Cause	What to do
--------------	-------------------

<p>You may not be using the correct type of paper for your printer.</p>	<p>If the surface of your paper is too rough, printed characters may appear distorted or broken. EPSON special paper, or smooth, high-quality copier paper is recommended for best results. See "Available paper types" on page 276 for information on choosing paper.</p>
<p>The paper path inside the printer may be dusty.</p>	<p>Turn off the printer. Clean internal printer components by printing three pages with only one character per page.</p>

White dots appear in the printout

Cause	What to do
<p>The paper path inside the printer may be dusty.</p>	<p>Turn off the printer. Clean internal printer components by printing three pages with only one character per page.</p>

Print quality or tone is uneven

Cause	What to do
<p>Your paper may be moist or damp.</p>	<p>Do not store paper in a humid or damp environment.</p>
<p>There may be no toner left in the imaging cartridge.</p>	<p>If the message on the LCD panel or in EPSON Status Monitor indicates that the amount of toner left is low, see "Replacing an imaging cartridge" on page 214.</p> <p>You can also check the remaining toner with the following symbols on the Basic Settings tab in the printer driver.</p> <p>Toner low: ! Toner end: x</p>
<p>The Density setting may be too low.</p>	<p>Increase the Density setting in the Printing Menu on the control panel.</p>

Half-tone images print unevenly

Cause	What to do
Your paper may be moist or damp.	Do not store paper in a humid or damp environment. Be sure to use paper that is newly unwrapped.
There may be no toner left in the imaging cartridge.	If the message on the LCD panel or in EPSON Status Monitor indicates that the amount of toner left is low, see "Replacing an imaging cartridge" on page 214. You can also check the remaining toner with the following symbols on the Basic Settings tab in the printer driver. Toner low: ! Toner end: x
The gradation setting is too small when printing graphics.	On the Basic Settings tab in the printer driver, click the Advanced and select the More Settings button. Then select the Halftoning.

Toner smudges

Cause	What to do
Your paper may be moist or damp.	Do not store your paper in a humid or damp environment.
You may not be using the correct type of paper for your printer.	EPSON special paper or smooth, high-quality copier paper is recommended for best results. See "Available paper types" on page 276 for information on choosing paper.
The paper path inside the printer may be dusty.	Turn off the printer. Clean internal printer components by printing three pages with only one character per page.

Areas are missing in the printed image

Cause	What to do
Your paper may be moist or damp.	This printer is sensitive to moisture absorbed by the paper. The higher the moisture content in the paper, the lighter the printout. Do not store paper in a humid or damp environment.
You may not be using the correct type of paper for your printer.	If the surface of your paper is too rough, printed characters may appear distorted or broken. EPSON special paper or smooth, high-quality copier paper is recommended for best results. See "Available paper types" on page 276 for information on choosing paper.

Completely blank pages are output

Cause	What to do
The printer may have loaded more than one sheet at a time.	Remove the paper stack and fan it. Tap it on a flat surface to even the edges, then reload the paper.
There may be no toner left in the imaging cartridge.	If the message on the LCD panel or in EPSON Status Monitor indicates that the amount of toner left is low, see "Replacing an imaging cartridge" on page 214. You can also check the remaining toner with the following symbols on the Basic Settings tab in the printer driver. Toner low: ! Toner end: x
The problem may be with your application or interface cable.	Print out a status sheet. See "Printing a Status Sheet" on page 245. If a blank page is ejected, the problem may be with the printer. Turn off the printer and contact your dealer.
The Paper Size setting may be incorrect.	Make sure the correct paper size is set in the Tray Menu on the control panel.

MP Tray Size setting may be incorrect.	When loading paper for which the size is not specified with Auto setting, specify the correct paper size on the MP Tray Size setting in the Tray Menu on the control panel.
The cartridge seal may not be pulled out of the imaging cartridge.	Make sure that the cartridge seal has been pulled out completely. See "Replacing an imaging cartridge" on page 214 for details.
The MP tray cover is not attached correctly.	Check the MP tray cover. Next, remove the imaging cartridge and confirm that there is no paper remaining in the printer, then reinstall the imaging cartridge.

The printed image is light or faint

Cause	What to do
Your paper may be moist or damp.	Do not store your paper in a humid or damp environment.
The Toner Save mode may be on.	Turn off the Toner Save mode using the printer driver or the printer's control panel menus. To modify the Toner Save mode using the printer driver, select the Advanced in the Basic Settings tab, and click the More Settings button. Deselect the Toner Save check box in the More Settings dialog.
There may be no toner left in the imaging cartridge.	If the message on the LCD panel or in EPSON Status Monitor indicates that the amount of toner left is low, see "Replacing an imaging cartridge" on page 214. You can also check the remaining toner with the following symbols on the Basic Settings tab in the printer driver. Toner low: ! Toner end: x
The Density setting may be too low.	Increase the Density setting in the Printing Menu on the control panel.

The non-printed side of the page is dirty

Cause	What to do
Toner may have spilled onto the paper feed path.	Clean internal printer components by printing three pages with only one character per page.

Memory Problems

Print quality decreased

Cause	What to do
The printer cannot print in the required quality level because of insufficient memory, and the printer lowers the quality automatically so that the printer can continue printing.	Check to see if the printout is acceptable. If not, add more memory for a permanent solution or lower print quality temporarily in the printer driver.

Insufficient memory for current task

Cause	What to do
The printer has insufficient memory for current task.	Add more memory for a permanent solution or lower print quality temporarily in the printer driver.

Insufficient memory to print all copies

Cause	What to do
--------------	-------------------

The printer does not have sufficient memory to collate print jobs.	Only one set of copies will be printed. Reduce the contents of print jobs, or add more memory. For information on installing more memory, see "Memory Module" on page 202.
--	--

Paper Handling Problems

Paper does not feed properly

Cause	What to do
The paper guides are not set correctly.	Make sure that the paper guides in all the paper cassettes are set in the correct paper size positions.
The paper source setting may not be correct.	Make sure that you have selected the correct paper source in your application.
There may be no paper in the paper cassettes.	Load paper into the selected paper source.
The size of loaded paper differs from the control panel setting.	Make sure that the correct paper size is set in the control panel's Paper Source and MP Tray Size settings.
Too many sheets may be loaded in the paper cassette.	Make sure that you have not tried to load too many sheets of paper. For the maximum paper capacity for each paper source, see "MP tray" on page 38.
If paper does not feed from the optional 550-Sheet Universal Paper Cassette Unit, the unit may not be installed properly.	For instructions on installing the unit, see "550-Sheet Universal Paper Cassette Unit" on page 194.

Problems Using Options

To confirm your options are installed correctly, print a status sheet. See "Printing a Status Sheet" on page 245 for details.

The message Invalid AUX /IF Card appears on the LCD panel

Cause	What to do
The printer cannot read the installed optional interface card.	Turn off the computer, then remove the card. Make sure the interface card is of a supported model.

Paper does not feed from the optional paper cassette

Cause	What to do
The optional lower paper cassette may not be installed properly.	See "550-Sheet Universal Paper Cassette Unit" on page 194 for instructions on installing an optional paper cassette unit.
The paper source setting may not be correct.	Make sure you have selected the proper paper source in your application.
There may be no paper in the paper cassette.	Load paper.
Too many sheets may be loaded in the paper cassette.	Make sure that you have not tried to load in with too many sheets of paper. For the maximum paper capacity for each paper source, see "MP tray" on page 38, "Standard lower paper cassette" on page 39, and "550-Sheet Universal Paper Cassette Unit" on page 39.
The paper size is not set correctly.	Make sure that the correct paper size is selected in the Tray Menu on the control panel.

Feed jam when using the optional paper cassette

Cause	What to do
The paper is jammed at the optional paper cassette.	See "Clearing Jammed Paper" on page 231 to clear jammed paper.

An installed option cannot be used

Cause	What to do
The installed option is not defined in the printer driver.	You have to make settings manually in the printer driver. See "Making Optional Settings" on page 85.

Correcting USB Problems

If you are having difficulty using printer with a USB connection, see if your problem is listed below, and take any recommended actions.

USB connections

USB cables or connections can sometimes be the source of USB problems. Try one or both of these solution.

- ❑ For best results, you should connect the printer directly to the computer's USB port. If you must use multiple USB hubs, we recommend that you connect the printer to the first-tier hub.

Windows operating system

Your computer must be a model pre-installed with Windows XP, Me, 98, 2000, or Server 2003, a model that was pre-installed with Windows 98 and upgraded to Windows Me, or a model that was pre-installed with Windows Me, 98, 2000, or Server 2003, and upgraded to Windows XP. You may not be able to install or run the USB printer driver on a computer that does not meet these specifications or that is not equipped with a built-in USB port.

For details about your computer, contact your dealer.

Printer software installation

Incorrect or incomplete software installation can lead to USB problems. Take note of the following and perform the recommended checks to ensure proper installation.

Checking printer software installation for Windows XP, 2000, or Server 2003

When using Windows XP, 2000, or Server 2003, you must follow the steps in the *Setup Guide* packed with the printer to install the printer software. Otherwise, Microsoft's Universal driver may be installed instead. To check if the Universal driver has been installed, follow the steps below.

1. Open the Printers folder, then right-click the icon of your printer.
2. Click Printing Preferences on the shortcut menu that appears, then right-click anywhere in the driver.

If About is displayed in the shortcut menu that appears, click it. If a message box with the words “Unidrv Printer Driver” appears, you must reinstall the printer software as described in the Setup Guide. If About is not displayed, the printer software has been installed correctly.

Note:

For Windows 2000, if the Digital Signature Not Found dialog box appears during the installation process, click Yes. If you click No, you will have to install the printer software again.

For Windows XP or Server 2003, if the Software Installation dialog box appears during the installation process, click Continue Anyway. If you click STOP Installation, you will have to install the printer software again.

Checking printer software in Windows Me or 98

If you canceled the plug-and-play driver installation in Windows Me or 98 before the procedure was complete, the USB printer device driver or the printer software may be incorrectly installed. Follow the directions below to ensure that the driver and printer software are installed correctly.

Note:

The screen shots shown in this section are taken from Windows 98. Windows Me screens may differ slightly.

1. Access the printer driver, see "Accessing the printer driver" on page 58, then click the Details tab.

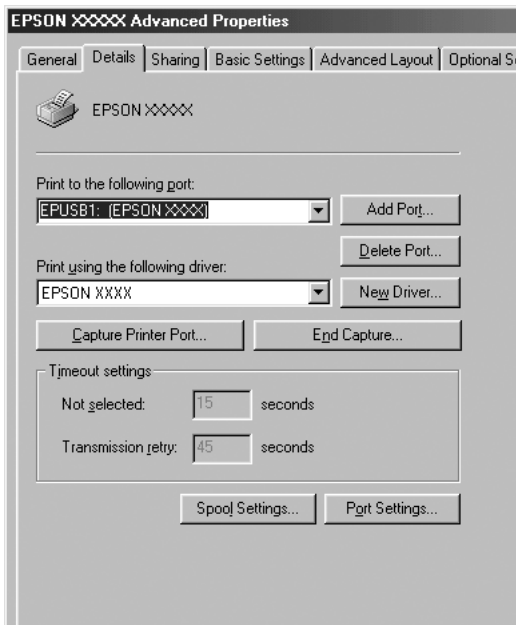

If EPUSBX: (your printer name) is displayed in the “Print to the following” port drop-down list, then the USB printer device driver and printer software are installed correctly. If the correct port is not displayed, proceed to the next step.

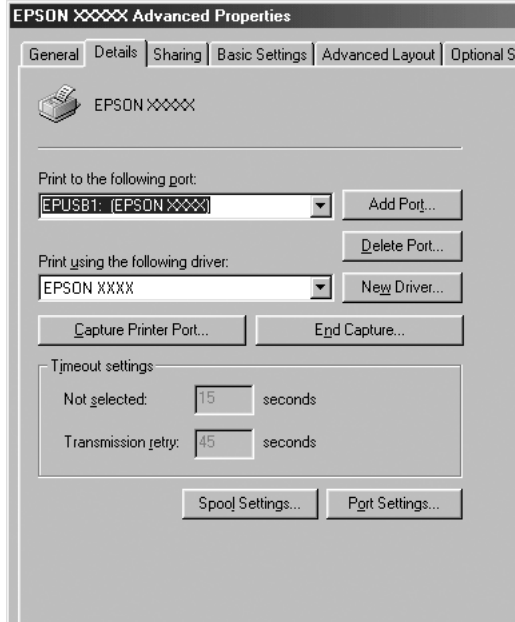

2. Right-click the My Computer icon on your desktop, then click Properties.
3. Click the Device Manager tab.

If your drivers are correctly installed, EPSON USB Printer Devices should appear on the Device Manager menu.

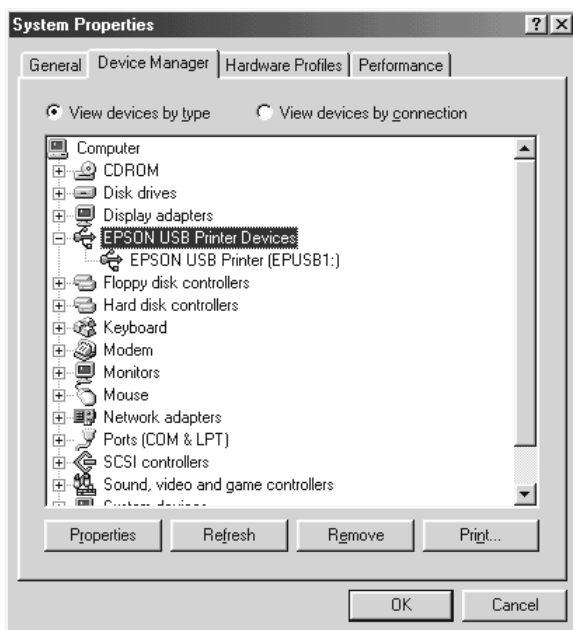

If EPSON USB Printer Devices does not appear on the Device Manager menu, click the plus(+) sign beside Other devices to view the installed devices.

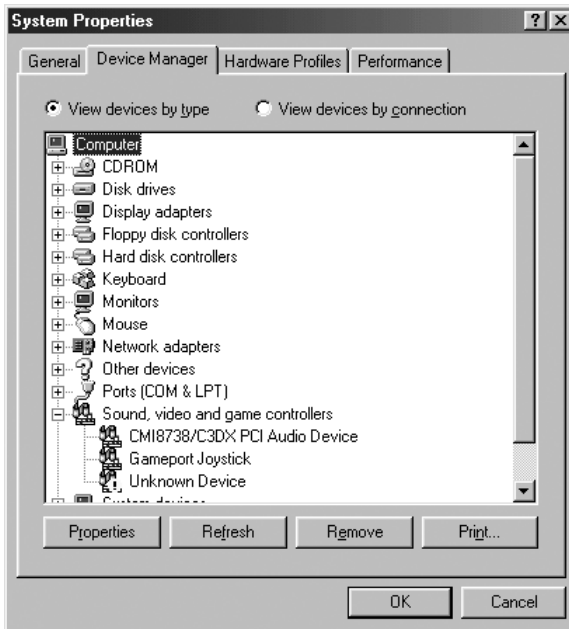

If USB Printer or your printer name appears under Other devices, the printer software is not installed correctly. Proceed to step 5.

If neither USB Printer nor your printer name appears under Other devices, click Refresh or unplug the USB cable from the printer, then plug it into the printer again. Once you've confirmed that these items appear, proceed to step 5.

- Under Other devices, select USB Printer or your printer name, click Remove, then click OK.

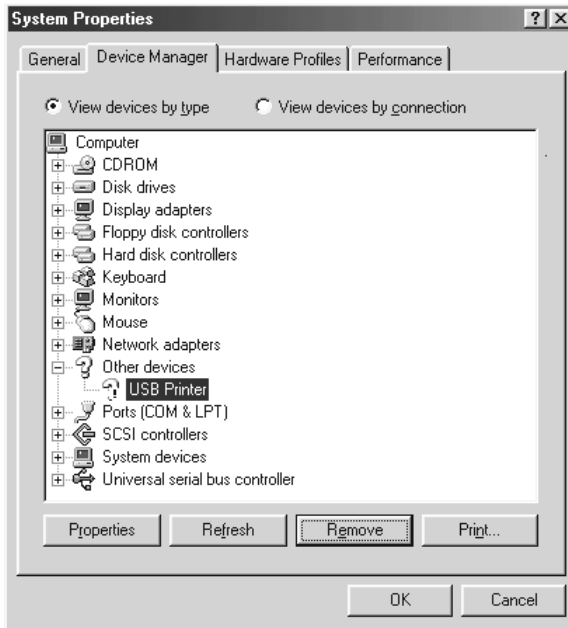

When the following dialog box appears, click OK, then click OK to close the System Properties dialog box.



5. Uninstall the printer software as explained in "Uninstalling the Printer Software" on page 105. Turn the printer off, restart your computer, then reinstall the printer software as described in the Setup Guide.

Status and Error Messages

You can see the printer's status and error messages on the LCD panel. For more information, see "Status and Error Messages" on page 181

Canceling Printing

You can cancel printing from your computer by using the printer driver or from the printer's control panel.

To cancel a print job before it is sent from your computer, for Windows, see "Canceling Printing" on page 104.

 Cancel Job button on your printer is the quickest and easiest way to cancel printing.

For instructions, see "Canceling Printing" on page 193.

Printing in the PostScript 3 Mode Problems

The problems listed in this section are those that you may encounter when printing with the PostScript driver. All procedural instructions refer to the PostScript printer driver.

The printer does not print correctly in the PostScript mode

Cause	What to do
The printer's emulation mode setting is incorrect.	<p>The printer is set to the <code>Auto</code> mode by default, so that it can automatically determine the encoding used in the received print job data and select the appropriate emulation mode. However, there are situations where the printer cannot select the correct emulation mode. In this case, it must be set manually to <code>PS3</code>.</p> <p>Set the emulation mode through the <code>SelectType Emulation</code> menu on the printer. See "Emulation Menu" on page 155.</p>
The printer's emulation mode setting for the interface that you are using is incorrect.	<p>The emulation mode can be set individually for each interface which receives print job data. Set the emulation mode for the interface you are using to <code>PS3</code>.</p> <p>Set the emulation mode through the <code>SelectType Emulation</code> menu on the printer. See "Emulation Menu" on page 155.</p>

The printer does not print

Cause	What to do
The Print to file check box is selected in the Print dialog box (except on Mac OS X).	Clear the Print to file check box in the Print dialog box.
The Save as File check box is selected on the Output Option sheet in the Print dialog box (Mac OS X only).	Clear the Save as File check box on the Output Option sheet in the Print dialog box.
An incorrect printer driver is selected.	Make sure that the PostScript printer driver that you are using to print is selected.

<p>For Mac OS 9 users only</p> <p>The Unlimited Downloadable Fonts check box on the PostScript Options setup option page in the Page Setup dialog box is selected.</p>	<p>Clear the Unlimited Downloadable Fonts check box.</p>
<p>The Emulation menu in the printer's Control Panel is set to a mode other than <i>Auto</i> or <i>PS3</i> for the interface that you are using.</p>	<p>Change the mode setting to either <i>Auto</i> or <i>PS3</i>.</p>

The printer driver or printer that you need to use does not appear in the Printer Setup Utility (Mac OS 10.3.x), Print Center (Mac OS 10.2.x), or Chooser (Mac OS 9)

Cause	What to do
<p>QuickDraw GX is in use (Mac OS 9).</p>	<p>This printer's driver does not support QuickDraw GX. Disable QuickDraw GX.</p>
<p>The printer name has been changed.</p>	<p>Ask the network administrator for details, then select the appropriate printer name.</p>
<p>The AppleTalk zone setting is incorrect.</p>	<p>Open the Printer Setup Utility (Mac OS 10.3.x), Print Center (Mac OS 10.2.x), or Chooser (Mac OS 9), then select the AppleTalk zone that the printer is connected to.</p>

The font on the printout is different from that on the screen

Cause	What to do

<p>The PostScript screen fonts are not installed.</p>	<p>The PostScript screen fonts must be installed on the computer that you are using. Otherwise, the font that you select is substituted by some other font for display on the screen.</p>
<p>For Windows users only</p> <p>The Send TrueType fonts to printer according to the font Substitution Table setting on the Fonts sheet of the printer's Properties dialog box is turned on, but the TrueType fonts are not replaced by the printer fonts. (For Windows Me 98)</p> <p>The appropriate substitution fonts are not correctly specified on the Device Settings sheet of the printer's Properties dialog box. (For Windows XP or 2000)</p>	<p>If the Send TrueType fonts to printer according to the font Substitution Table setting on the Fonts sheet of the printer's Properties dialog box is turned on, TrueType fonts are replaced by the printer fonts before they are printed. Specify the appropriate substitution fonts using the Font Substitution Table.</p> <p>Specify the appropriate substitution fonts using the Font Substitution Table.</p>

The printer fonts cannot be installed

Cause	What to do
<p>The Emulation menu in the printer's Control Panel is not set to P₃ for the interface that you are using.</p>	<p>Change the Emulation menu setting to P₃ for the interface that you are using, then try reinstalling the printer fonts again.</p>

The edges of texts and/or images are not smooth

Cause	What to do
<p>The Print Quality is set to Fast.</p>	<p>Change the Print Quality setting to Quality.</p>
<p>The printer does not have sufficient memory.</p>	<p>Increase the printer memory.</p>

The printer does not print normally via the parallel interface (Windows 98 only)

Cause	What to do
The computer is connected to the printer via the parallel interface and the parallel port setting is set to the ECP mode.	Make sure that the mode setting is correct.

The printer does not print normally via the USB interface

Cause	What to do
For Windows users only The Data Format setting in the printer's Properties is not set to ASCII or TBCP.	The printer cannot print binary data when it is connected to the computer via the USB interface. Make sure that the Data Format setting, which is accessed by clicking Advanced on the PostScript sheet of the printer's Properties, is set to ASCII or TBCP. If your computer is running Windows XP, click the Device Settings tab in the printer's Properties, then click the Output Protocol setting and select ASCII or TBCP.
For Macintosh users only The Data Format setting in the printer's Properties is not set to ASCII.	The printer cannot print binary data when it is connected to the computer via the USB interface. Make sure that the Data Format setting, which is accessed by clicking Print from the File menu, is set to ASCII.

The printer does not print normally via the network interface

Cause	What to do
--------------	-------------------

<p>The Data Format setting is different from the data format setting specified in the application (except on Mac OS X)</p>	<p>If the file is created in an application that allows you to change the data format or encoding, such as Photoshop, make sure that the setting in the application matches that in the printer driver.</p>
<p>The network connection is something other than AppleTalk, and the Data Format setting is not set to ASCII data.</p>	<p>If the network connection is something other than AppleTalk, make sure that the Data Format setting is set to ASCII data or Tagged binary communications protocol (Windows) or set to ASCII (Macintosh).</p>
<p>For Windows 2000 users only</p> <p>Job Management On is selected in the printer's Properties.</p>	<p>When AppleTalk is active and Job Management ON is selected, the printer does not print normally. Make sure to clear the Job Management On check box on the Job Settings sheet of the printer's Properties.</p>
<p>For Windows users only</p> <p>The computer is connected to the network using AppleTalk in a Windows 2000 environment, and the Send CTRL+D Before Each Job or Send CTRL+D After Each Job setting on the Device Settings sheet of the printer's Properties dialog box is set to Yes.</p>	<p>Make sure that both the Send CTRL+D Before Each Job and Send CTRL+D After Each Job settings are set to No.</p>
<p>For Windows users only</p> <p>The print data is too large.</p>	<p>Click Advanced on the PostScript sheet of the printer's Properties, then change the Data Format setting from ASCII data (default) to Tagged binary communications protocol.</p> <p>When the Binary setting is set to On, TBCP is not available. Use the Binary protocol. See "PS3 Menu" on page 171 for details.</p>
<p>For Windows users only</p> <p>Printing cannot be performed using the network interface.</p>	<p>Click Advanced on the PostScript sheet of the printer's Properties, then change the Data Format setting from ASCII data (default) to Tagged binary communications protocol.</p> <p>When the Binary setting is set to On, TBCP is not available. Use the Binary protocol. See "PS3 Menu" on page 171 for details.</p>

An undefined error occurs (Macintosh only)

Cause	What to do
The version of the Mac OS that you are using is unsupported.	This printer's driver can only be used on Macintosh computers running Mac OS 9 version 9.1 or later, and Mac OS X version 10.2.4 or later.

Insufficient memory to print data (Macintosh only)

Cause	What to do
The Macintosh printer driver uses available memory in the system to process print data.	<p>Try one of the following to free up memory for printing:</p> <ul style="list-style-type: none"><input type="checkbox"/> Reduce the RAM cache setting in the Memory control panel (Mac OS 9).<input type="checkbox"/> Close applications that are not in use.<input type="checkbox"/> Increase the memory allocation for the application that you are printing from (Mac OS 9).<input type="checkbox"/> Turn off background printing.

Printing in the PCL6 Mode Problems

The problems listed in this section are those that you may encounter when printing in the PCL6 mode. All procedural instructions, refer to the PCL6 printer driver.

The printer does not print

Cause	What to do
The Print to file check box is selected in the Print dialog box.	Clear the Print to file check box in the Print dialog box.

The font on the printout is different from that on the screen

Cause	What to do
The EPSON Font Manager fonts are not installed.	The EPSON Font Manager fonts must be installed on the computer that you are using. Otherwise, the font that you select is substituted by some other font for display on the screen.

The edges of texts and/or images are not smooth

Cause	What to do
The resolution is set to 300 dpi.	Access the printer driver, click the Graphics tab, then select 600 dpi as the resolution.
The printer does not have sufficient memory.	Increase the printer memory.
The RITech is set to Off.	Access the printer driver, click the Graphics tab, then select On for RITech from the drop-down list.

Where To Get Help

Technical Support Web Site

Go to <http://www.epson.com> and select the Support section of your local EPSON web site for the latest drivers, FAQs, manuals and other downloadables.

Epson's Technical Support Web Site provides help with problems that cannot be solved using the troubleshooting information in your product documentation. If you have a Web browser and can connect to the Internet, access the site at:

<http://support.epson.net/>

Contacting Customer Support

Before Contacting Epson

If your Epson product is not operating properly and you cannot solve the problem using the troubleshooting information in your product documentation, contact customer support services for assistance. Check your Pan-European Warranty Document for information on how to contact EPSON Customer support.

They will be able to help you much more quickly if you give them the following information:

- Product serial number
(The serial number label is usually on the back of the product.)

- ❑ Product model
- ❑ Product software version
(Click About, Version Info, or similar button in the product software.)
- ❑ Brand and model of your computer
- ❑ Your computer operating system name and version
- ❑ Names and versions of the software applications you normally use with your product

Technical Specifications

Paper

Since the quality of any particular brand or type of paper may be changed by the manufacturer at any time, Epson cannot guarantee the quality of any type of paper. Always test samples of paper stock before purchasing large quantities or printing large jobs.

Available paper types

Paper type	Description
Plain paper	Weight: 60 to 90 g/m ² (Recycled paper is acceptable.* ¹)
Envelopes	No paste and no tape No plastic window
Labels	The backing sheet should be covered completely, with no gaps between labels.
Thick paper	Weight: 91 to 157 g/m ²
Extra thick paper	Weight: 157 to 216 g/m ² * ²
Transparencies	Transparencies for black-and-white laser printers or copiers
Colored paper	Non-coated
Paper with letterhead	Paper and ink of letterheads must be compatible with laser printers.

*¹ Use recycled paper only under normal temperature and humidity conditions. Poor quality paper may reduce print quality, or cause paper jams and other problems.

*² When using extra thick paper, set the Paper Type setting in the printer driver to Extra Thick.

Paper that should not be used

You cannot use the following paper in this printer. It may cause printer damage, paper jams, and poor print quality:

- ❑ Media meant for other color laser printers, black-and-white laser printers, color copiers, black-and-white copiers, or ink jet printers

- ❑ Previously printed paper by any color laser printers, black-and-white laser printers, color copiers, black-and-white copiers, ink jet printers, or thermal transfer printers
- ❑ Carbon paper, carbonless paper, thermal-sensitive paper, pressure-sensitive paper, acid paper, or paper that uses high-temperature-sensitive ink (around 210°C)
- ❑ Labels that peel easily or labels that do not cover the backing sheet completely
- ❑ Coated paper or special surface-colored paper
- ❑ Paper that has binder holes or is perforated
- ❑ Paper that has glue, staples, paper clips, or tape on it
- ❑ Paper that attracts static electricity
- ❑ Moist or damp paper
- ❑ Paper of uneven thickness
- ❑ Overly thick or thin paper
- ❑ Paper that is too smooth or too rough
- ❑ Paper that is different on the front and back
- ❑ Paper that is folded, curled, wavy, or torn
- ❑ Paper of irregular shape, or paper that does not have right angle corners

Printable area

4-mm minimum margin on all sides

Note:

- ❑ *The printable area varies, depending on the emulation mode in use.*
- ❑ *When using ESC/Page language, there is 5-mm minimum margin on all sides.*

Printer

General

Printing method:	Laser beam scanning and dry electrophotographic process
Print Quality:	1200 RIT ^{*1}
Resolution:	600 dpi
Continuous printing speed ^{*2} (with A4/Letter):	30 pages per minute or less
Paper feed:	Automatic or manual feed
Paper feed alignment:	Center alignment for all sizes
Input paper supply:	
MP tray:	Up to 150 sheets of plain paper (75 g/m ²) Up to 10 envelopes Up to 100 sheets of transparencies Up to 75 sheets of labels
Standard lower paper cassette:	Up to 250 sheets of plain paper (75 g/m ²)
Paper output:	For all paper types and size
Paper output capacity:	Up to 250 sheets of plain paper (75 g/m ²)
Internal emulation:	PCL6/5e emulation (LJ4 mode)
	ECP/Page printer language
	ESC/P 2 24-pin printer emulation (ESC/P 2 mode)
	ESC/P 9-pin printer emulation (FX mode)
	IBM Proprinter emulation (1239X mode)
Resident fonts:	99 scalable fonts and 5 bitmap fonts
RAM:	64 MB, expandable up to 320 MB

*1 Resolution Improvement Technology

*2 Printing speed varies by paper source or other conditions.

Environmental

Temperature:	In use:	5 to 35°C (41 to 95°F)
	Not in use:	-20 to 40°C (-4 to 104°F)
Humidity:	In use:	15 to 85% RH
	Not in use:	5 to 85% RH
Altitude:	3,500 meters (11,500 feet) maximum	

Mechanical

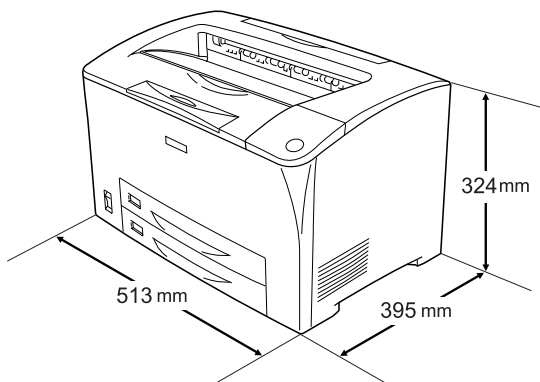

Weight:	Approx. 19.5 kg (about 43 lb), excluding the imaging cartridge and options
---------	--

Electrical

			220 V Model
Voltage			220 V-240 V \pm 10%
Rated frequency			50 Hz / 60 Hz \pm 3 Hz
Rated current			Less than 5.5 A
Power consumption	During printing	Average	500 W
		MAX	970 W
	During standby mode	Average	85 W
		Sleep mode*	

* Completely suspended. Compliant with the Energy Star program.

Standard and approvals

U.S. model:

Safety	UL 60950 CSA C22.2 No. 60950
EMC	FCC Part 15 Subpart B Class B CSA C108.8 Class B

European model:

Low Voltage Directive 73/23/EEC EMC Directive 89/336/EEC	EN 60950 EN 55022 Class B EN 55024 EN 61000-3-2 EN 61000-3-3
--	--

Laser safety

This printer is certified as a Class 1 laser product under the U.S. Department of Health and Human Services (DHHS) Radiation Performance Standard according to the Radiation Control for Health and Safety Act of 1968. This means that the printer does not produce hazardous laser radiation.

Since radiation emitted by the laser is completely confined within protective housings and external covers, the laser beam cannot escape from the machine during any phase of user operation.

Interfaces

Parallel interface

Use the IEEE 1284-I compliant parallel interface connector.

ECP mode/Nibble mode

USB interface

USB 2.0 Full Speed mode

Note:

Only computers equipped with a USB connector and running Windows Me, 98, XP, or 2000 support the USB interface.

Ethernet interface

You can use an IEEE 802.3 100BASE-TX/10 BASE-T straight-through shielded, twisted-pair interface cable with an RJ45 connector.

Options and Consumable Products

550-Sheet Universal Paper Cassette Unit

Product code:	C12C802002
Paper size:	A5, A4, A3, B5, B4, Letter (LT), Legal (LGL)
Paper weight:	60 to 90 g/m ² (16 to 24 lb)
Paper feed:	Automatic feed delivery system Paper cassette capacity up to 550 sheets of plain paper (75 g/m ²)
Paper types:	Plain paper
Power supply:	3.3 V/0.1 A, 24 V/1.2 A supplied by the printer
Model:	JDA-3
Dimensions and weight:	
Height:	143 mm (5.6 in.)
Width:	505 mm (19.9 in.)
Depth:	373 mm (14.7 in.)
Weight:	3.5 kg (7.7 lb), including paper cassette

Duplex Unit

Product code:	C12C813982
Paper size:	A5, A4, A3, B5, B4, Letter (LT), Legal (LGL), Half-Letter (HLT), Executive (EXE), Government Legal (GLG), Ledger (B)
Paper weight:	60 to 157 g/m ² (16 to 42 lb)
Paper feed:	Automatic feed delivery system
Paper types:	Plain paper, thick paper
Power supply:	3.3 V/0.1 A, 24 V/0.6 A supplied by the printer
Model:	JDA-4
Dimensions and weight:	
Height:	203.5 mm (8.0 in.)
Width:	435 mm (17.1 in.)
Depth:	68.5 mm (2.7 in.)
Weight:	1.7 kg (3.7 lb)

* This product conforms to CE marking requirements in accordance with EC Directive 89/336/EEC.

Memory module

Make sure that the DIMM you purchase is compatible with EPSON products. For details, contact the store where you purchased this printer or the EPSON sales company.

Memory size:	64 MB, 128 MB, or 256 MB
--------------	--------------------------

Imaging cartridges

Product code:	0290
Storage temperature:	0 to 35°C (32 to 95°F)
Storage humidity:	15 to 80% RH

Fuser unit

Product code:	3023*
Storage temperature:	-20 to 40°C (-4 to 104°F)
Storage humidity:	5 to 85% RH

* This product conforms to CE marking requirements in accordance with EC Directive 89/336/EEC.

Information about Fonts

Working with Fonts

EPSON BarCode Fonts (Windows Only)

EPSON BarCode Fonts let you easily create and print many types of bar codes.

Normally, bar code creation is a laborious process requiring you to specify various command codes, such as Start bar, Stop bar and OCR-B, in addition to the bar code characters themselves. However, EPSON BarCode Fonts are designed to add such codes automatically, allowing you to easily print bar codes that conform to a variety of bar code standards.

EPSON BarCode Fonts support the following types of bar codes.

Bar code Standard	EPSON BarCode	OCR-B	Check Digit	Comments
EAN	EPSON EAN-8	Yes	Yes	Creates EAN (abbreviated version) bar codes.
	EPSON EAN-13	Yes	Yes	Creates EAN (standard version) bar codes.
UPC-A	EPSON UPC-A	Yes	Yes	Creates UPC-A bar codes.
UPC-E	EPSON UPC-E	Yes	Yes	Creates UPC-E bar codes.

Code39	EPSON Code39	No	No	Printing of OCR-B and check digits can be specified with the font name.
	EPSON Code39 CD	No	Yes	
	EPSON Code39 CD Num	Yes	Yes	
	EPSON Code39 Num	Yes	No	
Code128	EPSON Code128	No	Yes	Creates Code128 bar codes.
Interleaved 2 of 5 (ITF)	EPSON ITF	No	No	Printing of OCR-B and check digits can be specified with the font name.
	EPSON ITF CD	No	Yes	
	EPSON ITF CD Num	Yes	Yes	
	EPSON ITF Num	Yes	No	
Codabar	EPSON Codabar	No	No	Printing of OCR-B and check digits can be specified with the font name.
	EPSON Codabar CD	No	Yes	
	EPSON Codabar CD Num	Yes	Yes	
	EPSON Codabar Num	Yes	No	

EAN128	EPSON EAN128	Yes	Yes	Creates EAN128 barcodes. Supported OS: Windows 2000/XP/Server 2003
--------	-----------------	-----	-----	--

System requirements

To use EPSON BarCode Fonts, your computer system should meet the following requirements:

Computer: IBM PC series or IBM compatible with an i386SX or higher CPU

Operating system: Microsoft Windows XP, Me, 98, 2000, or Server 2003

Hard disk: 15 to 30 KB free space, depending on the font.

Note:

EPSON BarCode Fonts can only be used with Epson printer drivers.

Installing EPSON BarCode Fonts

Follow the steps below to install EPSON BarCode Fonts. The procedure described here is for installation in Windows 98; the procedure for other Windows operating systems is nearly the same.

1. Make sure that the printer is off and that Windows is running on your computer.
2. Insert the printer software CD-ROM in the CD-ROM drive.

Note:

- ❑ *If the language section window appears, select your country.*

- ❑ *If the EPSON Installation Program screen does not appear automatically, double-click the My Computer icon, right-click the CD-ROM icon, and click OPEN in the menu that appears. Then double-click Epsetup.exe.*
3. Click User Installation.
 4. Click Custom Install.



5. Click EPSON BarCode Font.

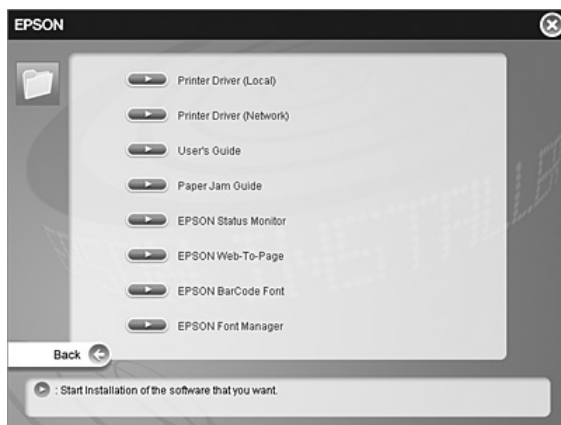

6. When the software license agreement screen appears, read the statement and then click Accept. Then follow the on-screen instructions.



7. When installation is complete, click OK.

EPSON BarCode Fonts are now installed on your computer.

Printing with EPSON BarCode Fonts

Follow the steps below to create and print bar codes using EPSON BarCode Fonts. The application featured in these instructions is Microsoft WordPad. The actual procedure may differ slightly when printing from other applications.

1. Open a document in your application and enter the characters you want to convert into a bar code.

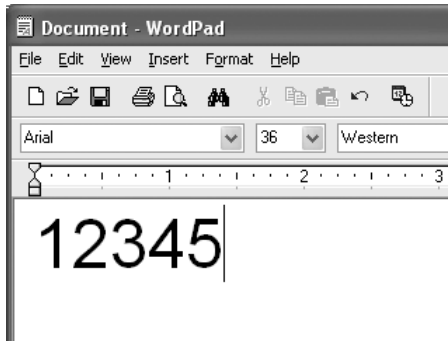

2. Select the characters, then select Font from the Format menu.

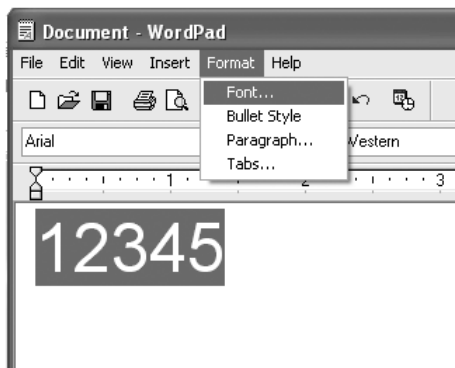

3. Select the EPSON BarCode Font you want to use, set the font size, then click OK.

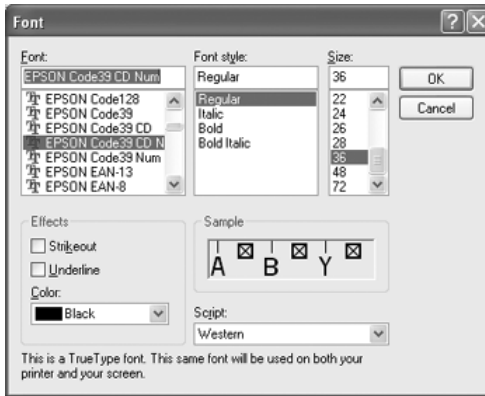

Note:

In Windows XP, 2000, or Server 2003, you cannot use font sizes larger than 96 points when printing bar codes.

4. The characters you selected appear as bar code characters similar to those shown below.

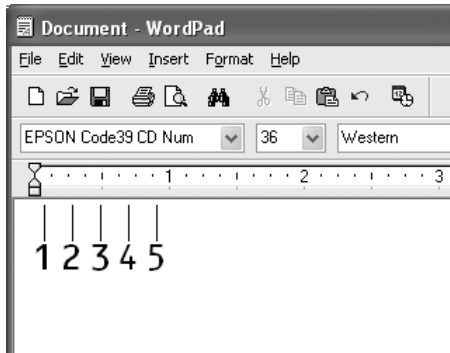

5. Select Print from the File menu, select your EPSON printer, then click Properties. Make the following printer driver settings. Your printer is a Black-and-White printer. See the Black-and-White Printer Driver section in the table below.

	Black-and-white Printer Driver	Color Printer Driver	HostBased Black-and-white Printer Driver	HostBased Color Printer Driver
Color	(not available)	Black	(not available)	Black
Print Quality	Text & Image*	Text & Image*	Text & Image*	Text & Image*
Toner Save	Not selected	Not selected	Not selected	Not selected
Zoom Options	Not selected	Not selected	Not selected	Not selected
Graphic mode (in the Extended Settings dialog box accessed through the Optional Settings tab)	High Quality (Printer)	(not available)	(not available)	(not available)
Printing Mode (in the Extended Settings dialog box accessed through the Optional Settings tab)	(not available)	High Quality (Printer)	(not available)	(not available)

* These settings are available when the Automatic check box is selected on the Basic Settings tab. When the Advanced check box is selected, click the More Settings button and set the Resolution or Print Quality to 600dpi.

6. Click OK to print the bar code.

Note:

If there is an error in the bar code character string, such as inappropriate data, the bar code will be printed as it appears on the screen, but it cannot be read by a bar code reader.

Notes on inputting and formatting bar codes

Please note the following when inputting and formatting bar code characters:

- ❑ Do not apply shading or special character formatting, such as bold, italic, or underline.
- ❑ Print bar codes in black and white only.
- ❑ When rotating characters, only specify rotation angles of 90°, 180°, and 270°.
- ❑ Turn off all automatic character and word spacing settings in your application.
- ❑ Do not use features in your application that enlarge or reduce the size of characters in only the vertical or horizontal direction.
- ❑ Turn off your application's auto-correct features for spelling, grammar, spacing, etc.
- ❑ To more easily distinguish bar codes from other text in your document, set your application to show text symbols, such as paragraph marks, tabs, etc.
- ❑ Because special characters such as Start bar and Stop bar are added when an EPSON BarCode Font is selected, the resulting bar code may have more characters than were originally input.

- ❑ For best results, use only the font sizes recommended in "BarCode Font specifications" on page 296 for the EPSON BarCode Font you are using. Bar codes in other sizes may not be readable with all bar code readers.

Note:

Depending on the print density, or on the quality or color of the paper, bar codes may not be readable with all bar code readers. Print a sample and make sure the bar code can be read before printing large quantities.

BarCode Font specifications

This section contains details on the character input specifications for each EPSON BarCode Font.

EPSON EAN-8

- ❑ EAN-8 is an eight-digit abbreviated version of the EAN bar code standard.
- ❑ Because the check digit is added automatically, only 7 characters can be input.

Character type	Numbers (0 to 9)
Number of characters	7 characters
Font size	52 pt to 130 pt (up to 96 pt in Windows XP/2000/Server 2003). Recommended sizes are 52 pt, 65 pt (standard), 97.5 pt, and 130 pt.

The following codes are inserted automatically and need not be input by hand:

- ❑ Left/Right margin
- ❑ Left/Right guard bar
- ❑ Center bar

- Check digit
- OCR-B

Print sample

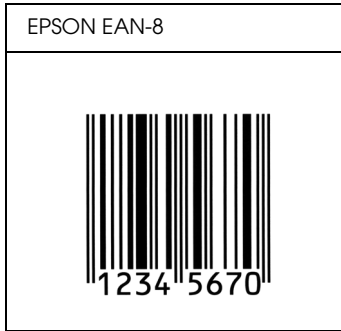

EPSON EAN-13

- EAN-13 is the standard 13-digit EAN bar code.
- Because the check digit is added automatically, only 12 characters can be input.

Character type	Numbers (0 to 9)
Number of characters	12 characters
Font size	60 pt to 150 pt (up to 96 pt in Windows XP/2000/Server 2003). Recommended sizes are 60 pt, 75 pt (standard), 112.5 pt, and 150 pt.

The following codes are inserted automatically and need not be input by hand:

- Left/Right margin
- Left/Right guard bar
- Center bar

- Check digit
- OCR-B

Print sample

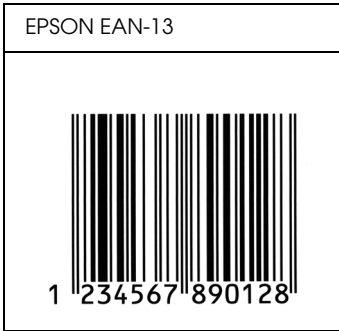

EPSON UPC-A

- UPC-A is the standard bar code specified by the American Universal Product Code (UPC Symbol Specification Manual).
- Only regular UPC codes are supported. Supplementary codes are not supported.

Character type	Numbers (0 to 9)
Number of characters	11 characters
Font size	60 pt to 150 pt (up to 96 pt in Windows XP/2000/Server 2003). Recommended sizes are 60 pt, 75 pt (standard), 112.5 pt and 150 pt.

The following codes are inserted automatically and need not be input by hand:

- Left/Right margin
- Left/Right guard bar

- Center bar
- Check digit
- OCR-B

Print sample

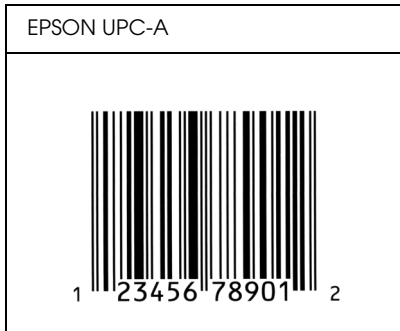

EPSON UPC-E

- UPC-E is the UPC-A zero-suppression (deletes extra zeros) bar code specified by the American Universal Product Code (UPC Symbol Specification Manual).

Character type	Numbers (0 to 9)
Number of characters	6 characters
Font size	60 pt to 150 pt (up to 96 pt in Windows XP/2000/Server 2003). Recommended sizes are 60 pt, 75 pt (standard), 112.5 pt, and 150 pt.

The following codes are inserted automatically and need not be input by hand:

- Left/Right margin
- Left/Right guard bar

- ❑ Check digit
- ❑ OCR-B
- ❑ The numeral “0”

Print sample

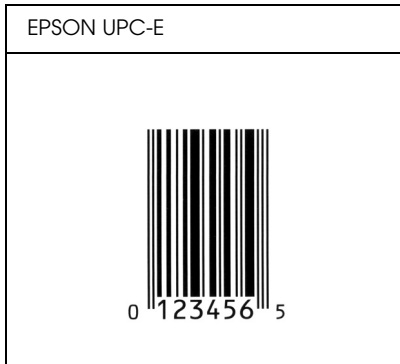

EPSON Code39





- ❑ Four Code39 fonts are available, allowing you to enable and disable the automatic insertion of check digits and OCR-B.
- ❑ The height of the bar code is automatically adjusted to 15% or more of its total length, in conformance to the Code39 standard. For this reason, it is important to keep at least one space between the bar code and the surrounding text to prevent overlapping.
- ❑ Spaces in Code39 bar codes should be input as “_” underbars.
- ❑ When printing two or more bar codes on one line, separate the bar codes with a tab, or select a font other than a BarCode Font and input the space. If a space is input while a Code39 font is selected, the bar code will not be correct.

Character type	Alphanumeric characters (A to Z, 0 to 9) Symbols (- . space \$ / + %)
Number of characters	No limit
Font size	When OCR-B is not used: 26 pt or more (up to 96 pt in Windows XP/2000/Server 2003). Recommended sizes are 26 pt, 52 pt, 78 pt, and 104 pt. When OCR-B is used: 36 pt or more (up to 96 pt in Windows XP/2000/Server 2003). Recommended sizes are 36 pt, 72 pt, 108 pt, and 144 pt.

The following codes are inserted automatically and need not be input by hand:

- Left/Right quiet zone
- Check digit
- Start/Stop character

Print sample

EPSON Code39	EPSON Code39 CD
	
EPSON Code39 Num	EPSON Code39 CD Num
 1 2 3 4 5 6 7	 1 2 3 4 5 6 7 S

EPSON Code128

- ❑ Code128 fonts support code sets A, B, and C. When the code set of a line of characters is changed in the middle of the line, a conversion code is automatically inserted.
- ❑ The height of the bar code is automatically adjusted to 15% or more of its total length, in conformance to the Code128 standard. For this reason, it is important to keep at least one space between the bar code and the surrounding text to prevent overlapping.
- ❑ Some applications automatically delete the spaces at the end of lines or change multiple spaces into tabs. Bar codes containing spaces may not be correctly printed from applications that automatically delete spaces from the ends of lines or change multiple spaces into tabs.
- ❑ When printing two or more bar codes on one line, separate the bar codes with a tab, or select a font other than a BarCode Font and input the space. If a space is input while Code128 is selected, the bar code will not be correct.

Character type	All ASCII characters (95 in total)
Number of characters	No limit
Font size	26 pt to 104 pt (up to 96 pt in Windows XP/2000/Server 2003). Recommended sizes are 26 pt, 52 pt, 78 pt, and 104 pt.

The following codes are inserted automatically and need not be input by hand:

- ❑ Left/Right quiet zone
- ❑ Start/Stop character
- ❑ Check digit

- ❑ Change code set character

Print sample

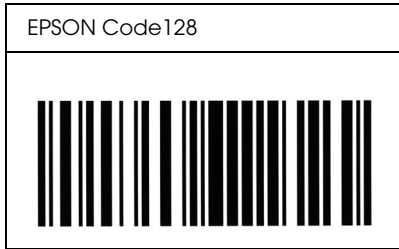

EPSON ITF

- ❑ The EPSON ITF fonts conform to the USS Interleaved 2-of-5 standard (American).
- ❑ Four EPSON ITF fonts are available, allowing you to enable and disable the automatic insertion of check digits and OCR-B.
- ❑ The height of the bar code is automatically adjusted to 15% or more of its total length, in conformance to the Interleaved 2-of-5 standard. For this reason, it is important to keep at least one space between the bar code and the surrounding text to prevent overlapping.
- ❑ Interleaved 2 of 5 treats every two characters as one set. When there are an odd number of characters, EPSON ITF fonts automatically add a zero to the beginning of the character string.



Character type	Numbers (0 to 9)
Number of characters	No limit

Font size	<p>When OCR-B is not used: 26 pt or more (up to 96 pt in Windows XP/2000/Server 2003). Recommended sizes are 26 pt, 52 pt, 78 pt, and 104 pt.</p> <p>When OCR-B is used: 36 pt or more (up to 96 pt in Windows XP/2000/Server 2003). Recommended sizes are 36 pt, 72 pt, 108 pt, and 144 pt.</p>
-----------	--

The following codes are inserted automatically and need not be input by hand:

- Left/Right quiet zone
- Start/Stop character
- Check digit
- The numeral “0” (added to the beginning of character strings as needed)

Print sample

EPSON ITF	EPSON ITF CD
	
EPSON ITF Num	EPSON ITF CD Num



EPSON Codabar

- ❑ Four Codabar fonts are available, allowing you to enable and disable the automatic insertion of check digits and OCR-B.
- ❑ The height of the bar code is automatically adjusted to 15% or more of its total length, in conformance to the Codabar standard. For this reason, it is important to keep at least one space between the bar code and the surrounding text to prevent overlapping.
- ❑ When either a Start or a Stop character is input, Codabar fonts automatically insert the complementary character.
- ❑ If neither a Start nor a Stop character is input, these characters are automatically input as the letter "A".





Character type	Numbers (0 to 9) Symbols (- \$: / . +)
Number of characters	No limit

Font size	<p>When OCR-B is not used: 26 pt or more (up to 96 pt in Windows XP/2000/Server 2003). Recommended sizes are 26 pt, 52 pt, 78 pt, and 104 pt.</p> <p>When OCR-B is used: 36 pt or more (up to 96 pt in Windows XP/2000/Server 2003). Recommended sizes are 36 pt, 72 pt, 108 pt, and 144 pt.</p>
-----------	--

The following codes are inserted automatically and need not be input by hand:

- Left/Right quiet zone
- Start/Stop character (when not input)
- Check digit

Print sample

EPSON Codabar	EPSON Codabar CD
	
EPSON Codabar Num	EPSON Codabar CD Num
 <p>A 1 2 3 4 5 6 7 A</p>	 <p>A 1 2 3 4 5 6 7 4 A</p>

EPSON EAN128

- ❑ EAN128 fonts support code sets A, B, and C. When the code set of a line of characters is changed in the middle of the line, a conversion code is automatically inserted.
- ❑ The following 4 kinds of the properties are supported as the Application Identifier (AI).

01: Global traded item number

10: Batch / Lot number

17: Expiry date

30: Quantity

- ❑ The height of the bar code is automatically adjusted to 15% or more of its total length, in conformance to the Code128 standard. For this reason, it is important to keep at least one space between the bar code and the surrounding text to prevent overlapping.
- ❑ Some applications automatically delete the spaces at the end of lines or change multiple spaces into tabs. Bar codes containing spaces may not be correctly printed from applications that automatically delete spaces from the ends of lines or change multiple spaces into tabs.
- ❑ When printing two or more bar codes on one line, separate the bar codes with a tab, or select a font other than a BarCode Font and input the space. If a space is input while EAN128 is selected, the bar code will not be correct.

Character type	Alphanumeric characters (A to Z, 0 to 9) Parenthesis are only for identification of the Application Identifier (AI) Only the capital letters are supported by the small letter key input.
----------------	---

Number of characters	It changes with the Application Identifier (AI). 01: 4 characters "(01)" and 13 numbers 17: 4 characters "(17)" and 6 numbers 10: 4 characters "(10)" and maximum of 20 alphanumeric characters 30: 4 characters "(30)" and maximum of 8 numbers
Font size	36 pt or more Recommended sizes are 36 pt, 72 pt

The following codes are inserted automatically and need not be input by hand:

- Left/Right quiet zone
- Start/Stop character
- FNC1 character

It inserts for discernment from Code128 and for a pause of the variable length application identifier.

- Check digit
- Change code set character

Print sample

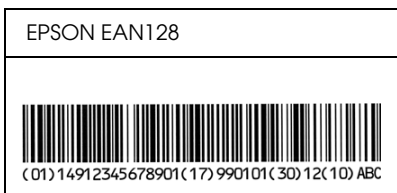

Available fonts

The following table lists the fonts that are installed in your printer. The names of all the fonts appear in your application software's font list if you are using the driver provided with the printer. If you are using a different driver, all of these fonts may not be available.

The fonts provided with the printer are shown below, according to the emulation mode.

LJ4 mode

Font Name	Family	HP Equivalent
Courier	Medium, Bold, Italic, Bold Italic	Courier
ITC Zapf Dingbats	-	ITC Zapf Dingbats
CG Times	Medium, Bold, Italic, Bold Italic	CG Times
CG Omega	Medium, Bold, Italic, Bold Italic	CG Omega
Coronet	-	Coronet
Clarendon Condensed	-	Clarendon Condensed
Univers	Medium, Bold, Medium Italic, Bold Italic	Univers
Univers Condensed	Medium, Bold, Medium Italic, Bold Italic	Univers Condensed
Antique Olive	Medium, Bold, Italic	Antique Olive
Garamond	Antiqua, Halbfett, Kursiv, Kursiv Halbfett	Garamond
Marigold	-	Marigold

Albertus	Medium, Extra Bold	Albertus
Ryadh	Medium, Bold	Ryadh
Malka	Medium, Bold, Italic	Miryam
Dorit	Medium, Bold	David
Naamit	Medium, Bold	Narkis
Arial	Medium, Bold, Italic, Bold Italic	Arial
Times New	Medium, Bold, Italic, Bold Italic	Times New
Helvetica	Medium, Bold, Oblique, Bold Oblique	Helvetica
Helvetica Narrow	Medium, Bold, Oblique, Bold Oblique	Helvetica Narrow
Palatino	Roman, Bold, Italic, Bold Italic	Palatino
ITC Avant Garde	Book, Demi, Book Oblique, Demi Oblique	ITC Avant Garde Gothic
ITC Bookman	Light, Demi, Light Italic, Demi Italic	ITC Bookman
New Century Schoolbook	Roman, Bold, Italic, Bold Italic	New Century Schoolbook
Times	Roman, Bold, Italic, Bold Italic	Times
ITC Zapf Chancery Italic	-	ITC Zapf Chancery Medium Italic
Symbol	-	Symbol
SymbolPS	-	SymbolPS
Wingdings	-	Wingdings
Letter Gothic	Medium, Bold, Italic	Letter Gothic
Naskh	Medium, Bold	Naskh

Koufi	Medium, Bold	Koufi
CourierPS	Medium, Bold, Oblique, Bold Oblique	CourierPS
Line Printer	-	Line Printer
OCR A	-	-
OCR B	-	-
Code39	9.37cpi, 4.68cpi	-
EAN/UPC	Medium, Bold	-

When selecting fonts in your application software, choose the font name listed in the HP Equivalent column.

Note:

Depending on the print density, or on the quality or color of the paper, OCR A, OCR B, Code39, and EAN/UPC fonts may not be readable. Print a sample and make sure the fonts can be read before printing large quantities.

ESC/P 2 and FX modes

Font Name	Family
Courier	Medium, Bold
EPSON Prestige	-
EPSON Roman	-
EPSON Sans serif	-
Arial	Medium, Bold
Letter Gothic	Medium, Bold
Times New Roman	Medium, Bold
EPSON Script	-
OCR A	-
OCR B	-

* Available only in ESC/P2 mode.

Note:

Depending on the print density, or on the quality or color of the paper, OCR A and OCR B fonts may not be readable. Print a sample and make sure the fonts can be read before printing large quantities.

I239X mode

Font Name	Family
Courier	Medium, Bold
EPSON Prestige	-
EPSON Gothic	-
EPSON Orator	-
EPSON Script	-
EPSON Presentor	-
EPSON Sans serif	-
OCR B	-

Note:

Depending on the print density, or on the quality or color of the paper, the OCR B font may not be readable. Print a sample and make sure the font can be read before printing large quantities.

PS 3 mode

Seventeen scalable fonts. The fonts include: Courier, Courier Oblique, Courier Bold, Courier Bold Oblique, Helvetica, Helvetica Oblique, Helvetica Bold, Helvetica Bold Oblique, Helvetica Narrow, Helvetica Narrow Oblique, Helvetica Narrow Bold, Helvetica Narrow Bold Oblique, Times Roman, Times Italic, Times Bold, Times Bold Italic, and Symbol.

PCL6 mode

For symbol set, see "In the PCL6 Mode" on page 328.

Scalable Font

Font Name	Symbol Set
Courier	*1
Courier Bold	*1
Courier Italic	*1
Courier Bold Italic	*1
Letter Gothic	*1
Letter Gothic Bold	*1
Letter Gothic Italic	*1
CourierPS	*1
CourierPS Bold	*1
CourierPS Oblique	*1
CourierPS Bold Oblique	*1
CG Times	*1

CG Times Bold	*1
CG Times Italic	*1
CG Times Bold Italic	*1
CG Omega	*1
CG Omega Bold	*1
CG Omega Italic	*1
CG Omega Bold Italic	*1
Coronet	*1
Clarendon Condensed	*1
Univers Medium	*1
Univers Bold	*1
Univers Medium Italic	*1
Univers Bold Italic	*1
Univers Medium Condensed	*1
Univers Bold Condensed	*1
Univers Medium Condensed Italic	*1
Univers Bold Condensed Italic	*1
Antique Olive	*1
Antique Olive Bold	*1
Antique Olive Italic	*1
Garamond Antiqua	*1
Garamond Halbfett	*1
Garamond Kursiv	*1
Garamond Kursiv Halbfett	*1
Marigold	*1
Albertus Medium	*1
Albertus Extra Bold	*1

Arial	*1
Arial Bold	*1
Arial Italic	*1
Arial Bold Italic	*1
Times New Roman	*1
Times New Roman Bold	*1
Times New Roman Italic	*1
Times New Roman Bold Italic	*1
Helvetica	*1
Helvetica Bold	*1
Helvetica Oblique	*1
Helvetica Bold Oblique	*1
Helvetica Narrow	*1
Helvetica Narrow Bold	*1
Helvetica Narrow Oblique	*1
Helvetica Narrow Bold Oblique	*1
Palatino Roman	*1
Palatino Bold	*1
Palatino Italic	*1
Palatino Bold Italic	*1
ITC Avant Garde Gothic Book	*1
ITC Avant Garde Gothic Demi	*1
ITC Avant Garde Gothic Book Oblique	*1
ITC Avant Garde Demi Oblique	*1
ITC Bookman Light	*1
ITC Bookman Demi	*1
ITC Bookman Light Italic	*1

ITC Bookman Demi Italic	*1
New Century Schoolbook Roman	*1
New Century Schoolbook Bold	*1
New Century Schoolbook Italic	*1
New Century Schoolbook Bold Italic	*1
Times Roman	*1
Times Bold	*1
Times Italic	*1
Times Bold Italic	*1
ITC Zapf Chancery Medium Italic	*1
Symbol	*2
Wingdings	*3
ITC Zapf Dingbats	*4
SymbolPS	*2

Bitmap Font

Font Name	Symbol Set
Line Printer	*5

Printing font samples

You can print samples of the fonts available in each mode by using the control panel's Information Menu. Follow these steps to print font samples.

1. Make sure that paper is loaded.
2. Make sure the LCD panel displays *Ready* or *Standby*, then press the  Enter button.

3. Press the ▼ Down button to select the font sample for the appropriate mode.
4. Press the  Enter button to print the selected font sample sheet.

Adding more fonts

You can add a wide variety of fonts to your computer. Most font packages include an installer for this purpose.

See your computer documentation for instructions on installing fonts.

Selecting fonts

Whenever possible select fonts in your application. See your software documentation for instructions.

If you are sending unformatted text to the printer directly from DOS or if you are using a simple software package that does not include font selection, you can select fonts using the printer's control panel menus when in the LJ4, ESC/P 2, FX, or I239X emulation mode.

Downloading fonts

Fonts that reside on your computer's hard disk can be downloaded, or transferred, to the printer so they can be printed. Downloaded fonts, also called soft fonts, remain in printer memory until you turn off the printer or otherwise reset it. If you plan on downloading many fonts, make sure your printer has sufficient memory.

Most font packages make it easy to manage fonts by providing their own installer. The installer gives you the option of having the fonts automatically downloaded whenever you start your computer or having fonts downloaded only when you need to print a particular font.

EPSON Font Manager (Windows Only)

EPSON Font Manager provides you with 131 software fonts.

System requirements

To use EPSON Font Manager, your computer system should meet the following requirements:

Computer:	IBM PC series or IBM compatible with an 486 or higher CPU
Operating system:	Microsoft Windows XP, Me, 98, 2000, or Server 2003 Internet Explorer 4.0 or higher
Hard disk:	At least 15 MB of free space

Installing EPSON Font Manager

Follow the steps below to install EPSON Font Manager.

1. Make sure that the printer is off and that Windows is running on your computer.
2. Insert the printer software CD-ROM in the CD-ROM drive.

Note:

- If the language selection window appears, select your country.*

- ❑ *If the EPSON Installation Program screen does not appear automatically, double-click the My Computer icon, right-click the CD-ROM icon, click OPEN in the menu that appears, then double-click Epsetup.exe.*
3. Click User Installation.
 4. Click Custom Install.



5. Click EPSON Font Manager. Then follow the on-screen instructions.



6. When installation is complete, click Finish.

EPSON Font Manager is now installed on your computer.

Symbol Sets

Introduction to symbol sets

Your printer can access a variety of symbol sets. Many of these symbol sets differ only in the international characters specific to each language.

Note:

Since most software handles fonts and symbols automatically, you will probably never need to adjust the printer's settings. However, if you are writing your own printer control programs, or if you are using older software that cannot control fonts, refer to the following sections for symbol set details.

When you are considering which font to use, you should also consider which symbol set to combine with the font. Available symbol sets vary depending on which emulation mode you use and which font you choose.

In the LJ4 Emulation Mode

The following symbol sets are available in LJ4 emulation mode.

Available typefaces	Symbol set name:	
19 Typefaces Courier CG Times Universe Letter Gothic Line Printer	IBM-US (10U)	Roman-8 (8U)
	ECM94-1 (0N)	8859-2 ISO (2N)
	8859-9 ISO (5N)	8859-10ISO (6N)
	IBM-DN (11U)	PcMultilingual (12U)
	Legal (1U)	8859-15ISO (9N)

19 Typefaces Courier CG Times Universe Letter Gothic	PcBlt775 (26U)	Pc1004 (9J)
	WIBALT (19L)	DeskTop (7J)
	PsText (10J)	Windows (9U)
	McText (12J)	MsPublishi (6J)
	PiFont (15U)	VeMath (6M)
	VeInternational (13J)	VeUS (14J)
	PcE.Europe (17U)	PcTk437 (9T)
	WiAnsi (19U)	WiE.Europe (9E)
	WiTurkish (5T)	UK (1E)
	Swedis2 (0S)	Italian (0I)
	Spanish (2S)	German (1G)
	Norweg1 (0D)	French2 (1F)
Roman-9 (4U)	PcEur858 (13U)	
19 Typefaces Courier CG Times Universe Letter Gothic Dorit Malka Naamit Naskh Koufi Ryadh	PsMath (5M)	Math-8 (8M)
	ANSI ASCII (0U)	
Courier CG Times Universe Letter Gothic	Pc866Cyr (3R)	Pc866Ukr (14R)
	WinCyr (9R)	Pc8Grk (12G)
	Pc851Grk (10G)	WinGrk (9G)
	ISOGrk (12N)	Greek8 (8G)
Courier CG Times Universe Letter Gothic Line Printer	ISOCyr (10N)	

Line Printer	Roman Extension (0E)	
Courier Letter Gothic Dorit Naamit Malka	Hebrew7 (0H) Hebrew8 (8H)	ISO 8859/8 Hebrew (7H) PC-862, Hebrew (15H)
Koufi Naasskh Ryadh	Arabic8 (8V) PC-864, Arabic (10V)	HPWARA (9V)
Symbol	Symbol (19M)	
Wingdings	Wingdings (579L)	
Zapf Digits	ZapfDigits (14L)	
OCR A	OCR A (0O)	
OCR B	OCR B (1O)	OCR B Extension (3Q)
Code3-9	Code3-9 (0Y)	
EAN/UPC	EAN/UPC (8Y)	

The 19 typefaces refer to those listed below:

CG Omega
Coronet
Clarendon Condensed
Univers Condensed
Antique Olive
Garamond
Marigold
Albertus
Arial
Times New
Helvetica
Helvetica NarrowPalatino
ITC Avant Garde Gothic
ITC Bookman
New Century Schoolbook
Times
ITC Zapf Chancery Medium Italic
CourierPS

In the ESC/P 2 or FX Modes

Character Table	Available typefaces			
	OCR B	Courier	EPSON Roman EPSON Sans serif EPSON Prestige EPSON Script	Letter Gothic Arial Times New
PcUSA	available	available	available	available
PcMultilingual	not available	available	available	available
PcPortuguese	not available	available	available	available
PcCanFrench	not available	available	available	available
PcNordic	not available	available	available	available
PcE.Europe	not available	available	not available	available
PcTurk2	not available	available	not available	available
PcIcelandic	not available	available	not available	available
BpBRASCI	not available	available	not available	available
BpAbicomp	not available	available	not available	available
Roman-8	not available	available	available	available
PcEur858	available	available	available	available
ISO Latin1	not available	available	not available	available

8859-15ISO	not available	available	available	available
PcSI437*	not available	available	not available	not available
PcTurk1*	not available	available	not available	not available
8859-9 ISO*	not available	available	not available	not available
Mazowia*	not available	available	not available	not available
CodeMJK*	not available	available	not available	not available
PcGk437*	not available	available	not available	not available
PcGk851*	not available	available	not available	not available
PcGk869*	not available	available	not available	not available
8859-7 ISO*	not available	available	not available	not available
PcCy855*	not available	available	not available	not available
PcCy866*	not available	available	not available	not available
Bulgarian*	not available	available	not available	not available
PcUkr866*	not available	available	not available	not available
Hebrew7*	not available	available	not available	not available
Hebrew8*	not available	available	not available	not available
PcHe862*	not available	available	not available	not available

PcAr864*	not available	available	not available	not available
PcLit771*	not available	available	not available	not available
PcLit774*	not available	available	not available	not available
Estonia*	not available	available	not available	not available
ISO Latin 2*	not available	available	not available	not available
PcLat866*	not available	available	not available	not available
PcAr864Ara*	not available	available	not available	not available
PcAr720*	not available	available	not available	not available

* Available only in ESC/P2 mode.

Times New is a type face compatible with RomanT.

Letter Gothic is a type face compatible with OratorS.

Arial is a type face compatible with SansH.

International character sets

You can select one of the following international character sets using the ESC R command:

Character sets: USA, France, Germany, UK, Japan,
Denmark1, Denmark2, Sweden, Italy,
Spain1, Spain2, Norway, Latin
America, Korea*, Legal*

* Available for ESC/P 2 emulation only

Characters available with the ESC (^ command

To print the characters in the table below, use the ESC (^ command.

CODE	0	1	7
0		▶	
1	☺	◀	
2	☹	↕	
3	♥	!!	
4	♦	¶	
5	♣		
6	♠	—	
7	·	±	
8	■	↑	
9	○	↓	
A	◻	→	
B	♂	←	
C	♀	↶	
D	♪	↷	
E	♫	▲	
F	♬	▼	△

In the I239X Emulation Mode

The available symbol sets in the I239X mode are PcUSA, PcMultilingual, PcEur858, PcPortuguese, PcCanFrench, PcNordic. See "In the ESC/P 2 or FX Modes" on page 325.

The available fonts are EPSON Sans Serif, Courier, EPSON Prestige, EPSON Gothic, EPSON Presentor, EPSON Orator, and EPSON Script.

In the PCL6 Mode

Symbol Set Name	Attribute	Font Classification				
		*1	*2	*3	*4	*5

ISO 60: Danish/Norwegian	4	○	-	-	-	-
ISO 15: Italian	9	○	-	-	-	-
ISO 8859/1 Latin 1	14	○	-	-	-	○
ISO 11: Swedish	19	○	-	-	-	-
ISO 6: ASCII	21	○	-	-	-	-
ISO 4: United Kingdom	37	○	-	-	-	-
ISO 69: French	38	○	-	-	-	-
ISO 29: German	39	○	-	-	-	-
Legal	53	○	-	-	-	○
ISO 8859/2 Latin 2	78	○	-	-	-	○
ISO 17: Spanish	83	○	-	-	-	-
Roman-9	149	○	-	-	-	-
Ps Math	173	○	-	-	-	-
ISO 8859/9 Latin 5	174	○	-	-	-	○
Windows 3.1 Latin 5	180	○	-	-	-	-
Microsoft Publishing	202	○	-	-	-	-
ISO 8859/10 Latin 6	206	○	-	-	-	○
DeskTop	237	○	-	-	-	-
Math-8	269	○	-	-	-	-
Roman-8	277	○	-	-	-	○

Windows 3.1 Latin 2	293	○	-	-	-	-
Pc1004	298	○	-	-	-	-
ISO 8859/15 Latin 9	302	○	-	-	-	-
PC-8 Turkish	308	○	-	-	-	-
Windows 3.0 Latin 1	309	○	-	-	-	-
PS Text	330	○	-	-	-	-
PC-8, Code Page 437	341	○	-	-	-	○
PC-8, D/N, Danish/Norwegian	373	○	-	-	-	○
MC Text	394	○	-	-	-	-
PC-850, Multilingual	405	○	-	-	-	○
PcEur858	437	○	-	-	-	-
Pi Font	501	○	-	-	-	-
PC852, Latin 2	565	○	-	-	-	-
Unicode 3.0	590	○	-	-	-	-
Windows Baltic	620	○	-	-	-	-
Windows 3.1 Latin/Arabic	629	○	-	-	-	-
PC-755	853	○	-	-	-	-
Wingdings	18540	-	-	○	-	-
Symbol	621	-	○	-	-	-
ZapfDingbats	460	-	-	-	○	-

Index

Numerics

- 550-Sheet Universal Paper Cassette Unit
 - about, 195
 - installing, 195
 - removing, 198
 - specifications, 283

A

- AUX menu, 168
- Available paper, 276

C

- Canceling printing, 193, 265
 - from printer driver (Windows), 104
- Characters available with the ESC (^ command), 328
- Consumables
 - replacement messages, 212
 - replacing the fuser unit, 217
- Contacting EPSON, 273
- Contacting Epson, 273
- Control panel
 - overview, 28
 - settings, 149
- Control panel menus
 - about, 149
 - AUX, 168
 - emulation, 155
 - ESCP2, 172
 - FX, 175
 - how to access, 149
 - I239X, 178
 - information, 151
 - LJ4, 168
 - network, 168
 - parallel, 164
 - printing, 155
 - PS3, 171
 - reset, 163
 - setup, 158

- tray, 153
- USB, 166
- Control panel settings
 - when to use, 149
- Customer support, 273

D

- Duplex Unit
 - installing, 198
 - removing, 201
 - specifications, 284

E

- Emulation menu, 155
- Envelopes
 - loading, 53
 - the use of, 51
- EPSON BarCode Fonts
 - about, 286
 - how to install, 288
 - how to print, 291
 - specifications, 296
 - system requirements, 288
- EPSON Font Manager
 - about, 318
 - how to install, 318
 - system requirements, 318
- EPSON Status Monitor
 - About EPSON Status Monitor (Windows), 91
 - Accessing EPSON Status Monitor (Windows), 89
 - Consumables Information (Windows), 94
 - Getting printer simple status (Windows), 92
 - Getting printer status details (Windows), 93
 - Installing EPSON Status Monitor (Windows), 86
 - Job Information (Windows), 96
 - Monitoring Your Printer Using EPSON Status Monitor (Windows), 86
 - Notice Settings (Windows), 99
 - Order Online, 100
 - Tray Icon Settings, 102
- ESC/P 2 and FX modes, 311
- ESC/P 2 or FX modes, 325
- ESCP2 menu, 172
- Ethernet, 282

F

Features

- Adobe PostScript 3 Mode, 32
- High-quality printing, 31
- PCL6 Emulation Mode, 32
- Resolution Improvement Technology (RITech), 31
- Toner save mode, 31
- Wide variety of fonts, 32

Fonts

- adding fonts, 317
 - available fonts, 309
 - downloading fonts, 317
 - EPSON BarCode Fonts (about), 286
 - EPSON BarCode Fonts (how to install), 288
 - EPSON BarCode Fonts (how to print), 291
 - EPSON BarCode Fonts (specifications), 296
 - EPSON BarCode Fonts (system requirements), 288
 - EPSON Font Manager (about), 318
 - EPSON Font Manager (how to install), 318
 - EPSON Font Manager (system requirements), 318
 - ESC/P 2 and FX modes, 311
 - how to print samples, 316
 - I239X mode, 312
 - LJ4 mode, 309
 - PCL6 mode, 313
 - PS 3 mode, 313
 - selecting fonts, 317
- ### Fuser unit
- handling precautions, 217
 - replacing, 218
 - specifications, 285
- ### FX menu, 175

G

Guides

- Network Guide, 24
- Online Help, 24
- Paper Jam Guide, 24
- Setup Guide, 24
- User's Guide, 24

H

Help

Epson, 273

I

I239X emulation mode, 328

I239X menu, 178

I239X mode, 312

Imaging cartridges

handling precautions, 213

replacing, 214

specifications, 285

Information menu, 151

Installing

550-Sheet Universal Paper Cassette Unit, 195

Duplex Unit, 198

memory modules, 202

Installing options

interface cards, 208

Installing the PostScript printer driver for the network interface (Windows), 133

Installing the PostScript printer driver for the parallel interface (Windows), 129

Installing the PostScript printer driver for the USB interface (Windows), 131

Interface cards

removing, 211

Interfaces

ethernet, 282

parallel, 282

USB, 282

International character sets, 327

L

Labels

driver settings, 54

printer settings, 54

LJ4 emulation mode, 321

LJ4 menu, 168

LJ4 mode, 309

Loading paper

custom size paper, 56

envelopes, 53

MP tray, 43

M

Maintenance

- consumables, 217

Memory module

- specifications, 284

Memory modules

- installing, 202

- removing, 207

MP tray

- available paper, 38

N

Network menu, 168

O

Options

- 550-Sheet Universal Paper Cassette Unit, 195

- Duplex Unit, 198

- memory modules, 202

- specifications (duplex unit), 284

- specifications (fuser unit), 285

- specifications (imaging cartridges), 285

- specifications (memory module), 284

Output tray

- face-down tray, 50

Overlay

- different printer settings (Windows), 82

- how to create (Windows), 76

- how to print (Windows), 80

- how to use (Windows), 76

P

Paper

- available paper, 276

- labels, 54

- loading the MP tray, 43

- loading the optional 550-Sheet Universal Lower Paper Cassette Unit, 49

- loading the standard lower paper cassette, 43

- printable area, 277

- transparencies, 56

- unavailable paper, 276

- Paper jams
 - All paper cassettes and Cover A, 242
 - Cover A, 232
 - Cover A or B, 235
 - Cover DM, 240
 - how to clear, 231
- Paper sources
 - 550-Sheet Universal Paper Cassette Unit, 39
 - MP tray, 38
 - selecting a paper source (automatically), 40
 - selecting a paper source (manually), 40
 - Standard lower paper cassette, 39
- Parallel, 282
- Parallel menu, 164
- PCL6 mode, 313, 328
- PCL6 printer driver
 - About the PCL6 Mode, 146
 - hardware requirements, 146
 - system requirements, 146
- Pickup roller
 - cleaning, 223
- PostScript printer driver
 - About the PostScript 3 Mode, 127
 - Accessing the PostScript printer driver (Macintosh), 143
 - Accessing the PostScript printer driver (Windows), 134
 - Installing the PostScript printer driver for Mac OS 9 users, 138
 - Installing the PostScript printer driver for Mac OS X users, 137
 - Selecting a printer in a network environment for Mac OS 9 users, 142
 - Selecting a printer in a network environment for Mac OS X users, 140
 - Selecting the printer when it connected via a USB connection for Mac OS 9 users, 139
 - system requirements (Macintosh), 128
 - system requirements (Windows), 127
- PostScript printer driver settings
 - Making changes to PostScript printer settings (Macintosh), 143
 - Making changes to PostScript printer settings (Windows), 135
 - Using AppleTalk under Windows 2000, 136
- Predefined print settings
 - Using the predefined settings (Windows), 61
- Printer
 - cleaning, 223
 - consumable products, 30
 - electrical, 281
 - environmental, 280
 - general, 279

- locating, 229
- mechanical, 280
- optional products, 29
- parts (front view), 25
- parts (inside), 27
- parts (rear view), 26
- standard and approvals, 281
- Printer driver
 - About the Printer Software (Windows), 58
 - Accessing the printer driver (Windows), 58
 - Uninstalling the printer driver (Windows), 105
 - Uninstall the USB device driver (Windows), 108
- Printer driver settings
 - automatically resizing printout (Windows), 68
 - Canceling Printing (Windows), 104
 - Creating an overlay (Windows), 76
 - customizing print settings (Windows), 62
 - different printer settings overlay data (Windows), 82
 - Duplex printing (Windows), 65
 - Making a new watermark (Windows), 74
 - Making Extended settings (Windows), 82
 - Making Optional settings (Windows), 85
 - Printing with an overlay (Windows), 80
 - Printing with the Duplex Unit (Windows), 65
 - print layout (Windows), 71
 - print quality (Windows), 59
 - print settings (Windows), 61
 - resizing printout (Windows), 69
 - saving (Windows), 64
 - Setting Up the USB connection (Windows), 103
 - Using an overlay (Windows), 76
 - Using a watermark (Windows), 73
- Printing menu, 155
- Print layout
 - Modifying the print layout (Windows), 71
- Print quality settings
 - Making the print quality settings (Windows), 59
- Problems, solving
 - contacting Epson, 273
- PS3 menu, 171
- PS 3 mode, 313

R

- Removing

- 550-Sheet Universal Paper Cassette Unit, 198
- Duplex Unit, 201
- interface cards, 211
- memory modules, 207
- Reset menu, 163
- Resizing page
 - Resizing pages by a specified percentage (Windows), 69
 - To automatically resize pages to fit the output paper (Windows), 68

S

- Saving customized settings
 - Saving your settings (Windows), 64
- Service, 273
- Setup menu, 158
- Sharing the printer
 - Installing the printer driver from the CD-ROM (Windows), 125
 - Setting up clients (Windows), 118
 - Setting up your printer as shared printer (Windows), 111
 - Sharing the printer (Windows), 110
 - Using an additional driver (Windows), 112
- Status and error messages, 181
- Status sheet
 - how to print, 192, 245
- Symbol sets
 - Characters available with the ESC (^) command, 328
 - ESC/P 2 or FX modes, 325
 - I239X emulation mode, 328
 - International character sets, 327
 - introduction, 320
 - LJ4 emulation mode, 321
 - PCL6 mode, 328

T

- Technical support, 273
- Thick paper
 - driver settings, 55
- Transparencies
 - printer settings, 56
- Transporting the printer
 - for long distances, 227
 - for short distances, 227
- Tray menu, 153
- Troubleshooting, 181, 192, 231, 245, 265

- memory problems, 254
- operational problems, 245
- options, 256
- paper handling problems, 255
- PCL6 mode, 272
- PostScript 3 mode, 265
- print quality problems, 249
- Status and Error Messages, 265
- USB problems, 257

U

- Unavailable paper, 276
- USB, 282
- USB menu, 166

W

- Watermark (Windows)
 - how to make, 74
 - how to use, 73