

## EpsonNet 802.11b/g Wireless and 10/100 Base Tx Ext. Print Server

No part of this publication may be reproduced, stored in a retrieval system, or transmitted in any form or by any means, mechanical, photocopying, recording, or otherwise, without the prior written permission of Seiko Epson Corporation. No patent liability is assumed with respect to the use of the information contained herein. Neither is any liability assumed for damages resulting from the use of the information contained herein.

Neither Seiko Epson Corporation nor its affiliates shall be liable to the purchaser of this product or third parties for damages, losses, costs, or expenses incurred by purchaser or third parties as a result of: accident, misuse, or abuse of this product or unauthorized modifications, repairs, or alterations to this product, or (excluding the U.S.) failure to strictly comply with Seiko Epson Corporation's operating and maintenance instructions.

Seiko Epson Corporation shall not be liable for any damages or problems arising from the use of any options or any consumable products other than those designated as Original Epson Products or Epson Approved Products by Seiko Epson Corporation.

EPSON Scan is based in part on the work of the Independent JPEG Group.

EPSON<sup>®</sup> and EPSON ESC/P<sup>®</sup> are registered trademarks and EPSON Stylus<sup>™</sup>, EPSON AcuLaser<sup>™</sup>, and EPSON ESC/P 2<sup>™</sup> are trademarks of Seiko Epson Corporation.

Speedo<sup>™</sup>, Fontware<sup>™</sup>, FaceLift<sup>™</sup>, Swiss<sup>™</sup>, and Dutch<sup>™</sup> are trademarks of Bitstream Inc.

AOSS<sup>™</sup> is a trademark of Buffalo, Inc.

CG Times<sup>®</sup> and CG Omega<sup>®</sup> are registered trademarks of Miles, Inc.

Univers<sup>®</sup> is a registered trademark of Linotype AG and/or its subsidiaries.

Antique Olive<sup>™</sup> is a trademark of Fonderie Olive.

Albertus<sup>™</sup> is a trademark of Monotype Corporation plc.

Coronet<sup>™</sup> is a trademark of Ludlow Industries (UK) Ltd.

Arial<sup>®</sup> and Times New Roman<sup>®</sup> are registered trademarks of Monotype Corporation plc.

Sun, Sun Microsystems, the Sun Logo, and the Java logo are trademarks or registered trademarks of Sun Microsystems, Inc. in the United States and other countries.

HP® and HP LaserJet® are registered trademarks of Hewlett-Packard Company.

Microsoft®, Windows®, and Windows NT® are registered trademarks of Microsoft Corporation.

Macintosh®, AppleTalk®, EtherTalk®, Bonjour® are registered trademarks of Apple Inc.

Adobe™ and PostScript™ are trademarks of Adobe Systems Incorporated, which may be registered in certain jurisdictions.

This product Includes software developed by the University of California, Berkeley, and Its contributors.

### **Info-ZIP copyright and license**

This is version 2005-Feb-10 of the Info-ZIP copyright and license. The definitive version of this document should be available at <ftp://ftp.info-zip.org/pub/infozip/license.html> indefinitely.

Copyright © 1990-2005 Info-ZIP. All rights reserved.

For the purposes of this copyright and license, “Info-ZIP” is defined as the following set of individuals:

Mark Adler, John Bush, Karl Davis, Harald Denker, Jean-Michel Dubois, Jean-loup Gailly, Hunter Goatley, Ed Gordon, Ian Gorman, Chris Herborth, Dirk Haase, Greg Hartwig, Robert Heath, Jonathan Hudson, Paul Kienitz, David Kirschbaum, Johnny Lee, Onno van der Linden, Igor Mandrichenko, Steve P. Miller, Sergio Monesi, Keith Owens, George Petrov, Greg Roelofs, Kai Uwe Rommel, Steve Salisbury, Dave Smith, Steven M. Schweda, Christian Spieler, Cosmin Truta, Antoine Verheijen, Paul von Behren, Rich Wales, Mike White

This software is provided “as is,” without warranty of any kind, express or implied. In no event shall Info-ZIP or its contributors be held liable for any direct, indirect, incidental, special or consequential damages arising out of the use of or inability to use this software.

Permission is granted to anyone to use this software for any purpose, including commercial applications, and to alter it and redistribute it freely, subject to the following restrictions:

- ❑ Redistributions of source code must retain the above copyright notice, definition, disclaimer, and this list of conditions.

- ❑ Redistributions in binary form (compiled executables) must reproduce the above copyright notice, definition, disclaimer, and this list of conditions in documentation and/or other materials provided with the distribution. The sole exception to this condition is redistribution of a standard UnZipSFX binary (including SFXWiz) as part of a self-extracting archive; that is permitted without inclusion of this license, as long as the normal SFX banner has not been removed from the binary or disabled.
- ❑ Altered versions--including, but not limited to, ports to new operating systems, existing ports with new graphical interfaces, and dynamic, shared, or static library versions--must be plainly marked as such and must not be misrepresented as being the original source. Such altered versions also must not be misrepresented as being Info-ZIP releases--including, but not limited to, labeling of the altered versions with the names "Info-ZIP" (or any variation thereof, including, but not limited to, different capitalizations), "Pocket UnZip," "WiZ" or "MacZip" without the explicit permission of Info-ZIP. Such altered versions are further prohibited from misrepresentative use of the Zip-Bugs or Info-ZIP e-mail addresses or of the Info-ZIP URL(s).
- ❑ Info-ZIP retains the right to use the names "Info-ZIP," "Zip," "UnZip," "UnZipSFX," "WiZ," "Pocket UnZip," "Pocket Zip," and "MacZip" for its own source and binary releases.

**General Notice:** Other product names used herein are for identification purposes only and may be trademarks of their respective owners. Epson disclaims any and all rights in those marks.

Copyright © 2007 Seiko Epson Corporation. All rights reserved.

## Warnings, Cautions, and Notes



*Warnings must be followed carefully to avoid bodily injury.*



*Cautions must be observed to avoid damage to your equipment.*

*Notes contain important information and useful tips on the operation of your printer.*

---

# Contents

Package Contents . . . . .	5
Supported Operating Systems . . . . .	7
Supported Epson Devices . . . . .	8
LEDs and Connectors . . . . .	10
How to Setup the Network Interface . . . . .	14
Overview . . . . .	14
Installing components on your computer . . . . .	15
Configuring the network interface . . . . .	18
Setting for printing and scanning (Windows) . . . . .	30
Setting up the printer (Macintosh) . . . . .	32
Using the device . . . . .	33
Scanning via a network . . . . .	33
Using the network for storage (Windows only) . . . . .	37
Restrictions on EPSON Status Monitor . . . . .	41

---

# Package Contents

Your network interface package includes the following items.

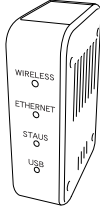

Network interface\*

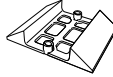

Stand



Anti-slip tape  
(For horizontal setup)

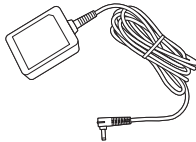

AC adapter

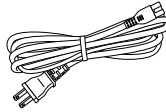

Power cord

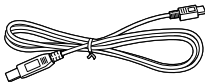

USB cable  
(USB2.0 compatible)

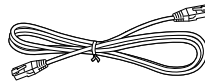

Ethernet cable  
(Category 5 shielded twisted-pair cable)



Software CD-ROM\*\*

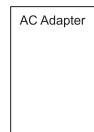

Precautions  
for AC Adapter

- \* The utility EpsonNet Config with Web Browser is pre-installed on this network interface.
- \*\* Software CD-ROM containing following software:
  - User's Guide (PDF-format manual)
  - Precautions for AC Adapter (PDF-format manual)
  - EpsonNet Config (for Windows)
  - EpsonNet Config (for Macintosh)
  - EpsonNet Print
  - EpsonNet SetupManager
  - EpsonNet Internet Print (Win)



**Caution:**

*Only use the AC adapter shipped with this package to supply power to the network interface.*

**Note:**

*You need to provide a computer that has either an Ethernet network interface or an 802.11b/g WLAN compliant network interface card. Also, you need an Epson device with a USB port as well as a hub or an access point (required for infrastructure mode only).*

---

## ***Supported Operating Systems***

The network interface supports the following operating systems.

Printing	Windows Vista Windows XP Windows Me/98/95 Windows 2000 Windows Server 2003 Windows NT 4.0 Mac OS X 10.2 or later Mac OS 9.1 or later
Scanning	See your device's manual for details about the supported operating systems.
Network Storage	Windows Vista Windows XP Windows Me/98SE Windows 2000 Windows Server 2003

---

## Supported Epson Devices

The network interface can be installed for the following Epson devices.

**Note:**

*For Macintosh systems, you have to set the AppleTalk entity type. Set it with Easy Install when configuring the network interface.*

Device Type	Model Name	AppleTalk Entity Type
Ink Jet Printer	Epson Stylus C66/C66PE/C86/C86PE/C87 Plus	EPSONLQ2
	Epson Stylus D68PE/ D87 Plus/D88/D88PE	
	Epson Stylus Photo 1280/2200	
	Epson Stylus Photo R200/R220/R240/R245/R265/ R270/R300/R320/R340/R360/ R800/R1800/R2400	
All-in-one	Epson Stylus CX3600/CX3650/CX6400/ CX6600	EPSONLQ2
	Epson Stylus DX4200/DX4250/DX4800/ DX4850/DX6000/DX6050	
	Epson Stylus RX420/RX425/RX500/RX520/ RX560/RX600/RX620/RX640/ RX700	
Laser Printer	EPL-6200	EPSONPAGE4
	EPL-N3000/N7000	
	Epson AcuLaser C1100/C3000	EPSONPAGES3
	Epson AcuLaser C2600/C4000/C4100/C4200/ C8600/C9100	EPSONPAGECOLOR1



Device Type	Model Name	AppleTalk Entity Type
Impact Dot Matrix Printer	FX-890/2190	EPSONFX
	DFX-9000	EPSONDFX
	LQ-590/630/2090	EPSONLQ2
	DLQ-3500	
	PLQ-20/20M	

**Note:**

*The default value of the AppleTalk entity type set in this product is EPSONLQ2.*

For the latest information on the supported devices and entity types, see the EPSON website at <http://www.epson.com/>.

---

## LEDs and Connectors

The status LEDs and status sheet provide you with important information about the operation and configuration of the network interface.

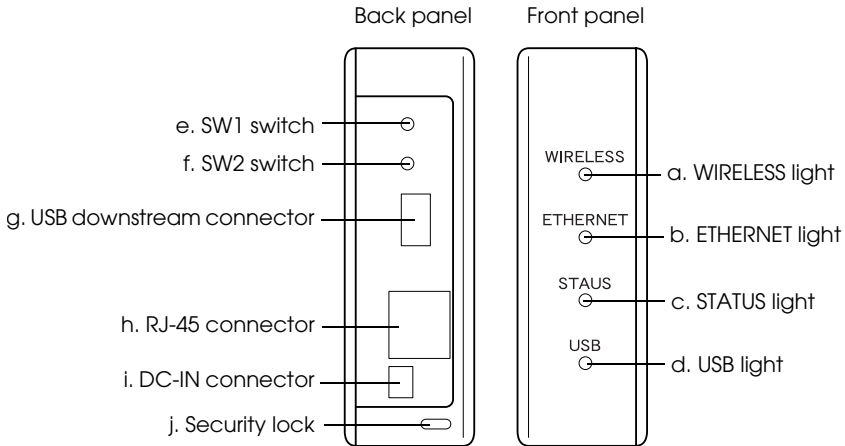

### ***a./b./c./d. Status LEDs***

The network interface has four lights (WIRELESS, ETHERNET, STATUS, and USB). These lights indicate the current operating status of the network interface when you first turn on the device, during normal operation, and when errors occur. The WIRELESS and ETHERNET lights are green. The STATUS and USB lights have three colors (red, green, and orange).

The status LEDs indicate the network interface status, as follows:

Network interface status	WIRELESS	ETHERNET	STATUS	USB
Initializing	Off	Off	Off	Green flashing

<b>Network interface status</b>	<b>WIRELESS</b>	<b>ETHERNET</b>	<b>STATUS</b>	<b>USB</b>
Wireless communication is available.	On	Off	Off	Green
Ethernet communication is available.	Off	On	Off	Green
No communication is available.	-	-	Red	-
Ready (100M link or 54M link)	-	-	Green	-
Ready (10M link or less than 48M link)	-	-	Orange	-
Printer communication is not available.	-	-	-	Red
Printer communication is available.	-	-	-	Green
Firmware update mode	-	-	-	Red and green lights flashing alternately
Error status	-	-	-	Red flashing
AOSS is available	On	Off	Orange flashing	Orange flashing
AOSS is not available	On	Off	Red flashing	Red flashing

**Note:**

*A hyphen indicates any one of the following statuses: On/Off/Flashing.*

## e. SW1 switch

The first time you use the network interface after installing or reinstalling it, plug the power cord of the network interface into a wall outlet while holding down the SW1 switch for about twenty seconds to initialize the network interface.

Before you start configuring the network interface, be sure to press and hold down the SW1 switch on the network interface to print a status sheet. A status sheet provides important information about the network interface, such as MAC address, SSID, device settings, and the device's current status. Press the SW1 switch once to print a simple status sheet, or twice to print a full status sheet. You cannot print a status sheet when the STATUS light is red.

### **Note:**

*If the device does not print a status sheet, make sure the device is online and no print jobs are being processed, then wait a minute. If it still does not print a status sheet, turn the device off, and then turn it back on again. The status sheet can be printed one minute after the device finishes warming up.*



### **Caution:**

*After turning off the device wait until the WIRELESS light and ETHERNET light go out before turning it back on; otherwise the network interface may not work correctly.*

## f. SW2 switch

Press the SW2 switch once to enter the AOSS mode. For details, see the documentation provided with your access point.

### **Note:**

*You can use this switch only when the access point you use is compatible with AOSS.*

### ***g. USB downstream connector***

This connector is used to connect a USB cable to the device to enable communication with the device.

### ***h. RJ-45 connector***

This connector is used to connect an Ethernet cable to the network. You can use this cable for both 10 Base-T and 100 Base-TX.



#### ***Caution:***

*You must use a Category 5 shielded twisted-pair cable to connect the network interface to prevent malfunction.*

### ***i. DC-IN connector***

This is an external power supply connector for the AC adapter shipped with the network interface. Plug or unplug the power cord of the network interface from a wall outlet to turn the network interface on or off.

### ***j. Security lock***

You can pass a commercially available theft-prevention cable through the security lock hole to secure the network interface to a table or pillar. This network interface is compatible with the Microsaver Security System manufactured by Kensington.

---

# How to Setup the Network Interface

## Overview

This section describes the general procedure on how to set up the network interface for use on a network.

1. Install the device driver.

See the manual provided with your device for information about the installation procedure.

In order to use devices (such as a printer) via a network, you need to install the device driver before setting up the network interface. If you want to print something, you need to install the printer driver. If you have all-in-one and you want to scan something, you need to install the scanner driver.

For printers in a Mac OS environment and scanning devices, you have to download the latest device driver that supports printing/scanning via a network from the EPSON Web site and install it on your computer. For the latest information on device drivers, see the EPSON Web site at <http://www.epson.com/>

2. Install EpsonNet Print. (For Windows Me/98 only)

**Note:**

*You have to install EpsonNet Print for the Windows Me/98 environment. See the online User's Guide for more information about the installation procedure. Be sure to restart the computer after installing the software.*

3. Install the necessary components on your computer.

Make sure the necessary network components are installed on the computer. See "Installing components on your computer" on page 15 for details.

4. Configure your network interface.

Configure your network interface using CD-ROM comes with network interface. See “Configuring the network interface” on page 18 for details.

## ***Installing components on your computer***

Before configuring the network interface, you need to install the necessary components. The following procedure explains how to install the TCP/IP protocol. To install other protocols, see the *online User’s Guide*.

***Note:***

*The Windows CD-ROM may be required during the installation.*

### ***Windows Vista***

1. Click Start, click Control Panel, and then click View network status and tasks or double-click Network and Sharing Center.
2. Click View Status, and then click the Properties button.
3. Double-click Internet Protocol Version 4 (TCP/IPv4) on the Local Area Connection Properties dialog box to open the Internet Protocol Version 4 (TCP/IPv4) Properties dialog box. Set the IP address, the subnet mask, etc. and then click OK.
4. Restart the computer.

### ***Windows XP***

1. Click Start, highlight Control Panel, and then click Network and Internet Connections. Select Network Connections.
2. Under LAN or High-Speed Internet, click the Local Area Connection icon.

3. Under Network Tasks, click Change settings of this connection.
4. Double-click Internet Protocol (TCP/IP) on the Local Area Connection Properties dialog box to open the Internet Protocols (TCP/IP) Properties dialog box. Set the IP address, the subnet mask, etc. and then click OK.
5. Restart the computer.

### **Windows Me/98/95**

1. Click Start, point to Settings, and then select Control Panel.
2. Double-click the Network icon. Check if the following necessary components are in the list of installed network components on the Configuration menu.

**If the TCP/IP protocol is not in the list:**

Click Add. Select Protocol and then click Add. Select Microsoft from the Manufacturers list and TCP/IP from the Network Protocols list. Then click OK.

3. Double-click TCP/IP on the Configuration menu to open the TCP/IP Properties dialog box. Set the IP address, the subnet mask, etc. and then click OK.
4. Restart the computer.

### **Windows 2000**

1. Click Start, point to Settings, and then select Network and Dial-up Connections. The Network and Dial-up Connections screen appears.
2. Right-click the desired network connection and then select Properties.



**If the TCP/IP protocol is not in the list:**

Click Install. Select Protocol and then click Add. In the Select Network Protocol dialog box, select Internet Protocol (TCP/IP) and then click OK.

3. Double-click Internet Protocol (TCP/IP) on the Configuration menu to open the TCP/IP Properties dialog box. Set the IP address, the subnet mask, etc. and then click OK.
4. Restart the computer.

### ***Windows Server 2003***

1. Click Start, point to Control Panel, and then select Network Connections. Click Local Area Connections.
2. Click the Properties.
3. Double-click Internet Protocol (TCP/IP) in the Local Area Connection Properties dialog box to open the Internet Protocols (TCP/IP) Properties dialog box. Set the IP address, the subnet mask, etc. and then click OK.
4. Restart the computer.

### ***Windows NT 4.0***

1. Click Start, point to Settings, and then select Control Panel.
2. Double-click the Network icon in the Control Panel, and then select the Protocols tab from the Network dialog box.

**If the TCP/IP protocol is not in the list:**

Click Add. Select the Protocols tab and then click Add. Select TCP/IP Protocol from the list and then click OK. Set the IP address, the subnet mask, etc. and then click OK.

Select the Services tab and then click Add. Select Microsoft TCP/IP Printing from the list and then click OK.

**If the TCP/IP protocol is in the list:**

Double-click TCP/IP Protocol in the list to open the Microsoft TCP/IP Properties dialog box. Set the IP address, the subnet mask, etc. and then click OK.

3. Restart the computer.

## **Mac OS X**

1. From the Apple menu, select System Preferences.
2. Open the Network control panel. Click the TCP/IP tab.
3. Select Built-in Ethernet from the Show pull down menu.
4. Assign an IP address and other settings if necessary.
5. Click the Apply Now button to save any changes.

## **Mac OS 9**

1. From the Apple menu, select Control Panel, and then TCP/IP.
2. Set Connect via to Ethernet.
3. Assign an IP address and other settings if necessary.
4. Close the dialog box to save any changes.

## **Configuring the network interface**

Follow the steps below to connect the network interface to the network.

**Note:**

- ❑ *Make sure that the device driver is installed on your computer before following the steps below. See the manual shipped with your device for instructions on how to install the device driver.*

- ❑ *You have to install EpsonNet Print for the Windows Me/98 environment beforehand. See the online User's Guide for more information about the installation procedure. Be sure to restart the computer after installing the software.*
  - ❑ *Depending on the settings of the network interface, some dialog boxes in the following steps may not be displayed.*
1. Insert the Software CD-ROM into the CD-ROM drive.

### **Windows**

If the Installer dialog box does not appear automatically, double-click EPSetup.exe on the CD-ROM.

### **Macintosh**

If the Installer dialog box does not appear automatically, double-click the EPSON CD-ROM icon on the desktop, and then double-click the appropriate OS icon in the EPSON folder.

2. Click Next on the CD Installer screen.
3. Read the license agreement, and then click Agree.
4. Select Easy Install: Start.



5. Select Network Interface Settings, and then click Next.

**Note:**

*You can display the online help for the settings of each screen by pressing the Help button.*

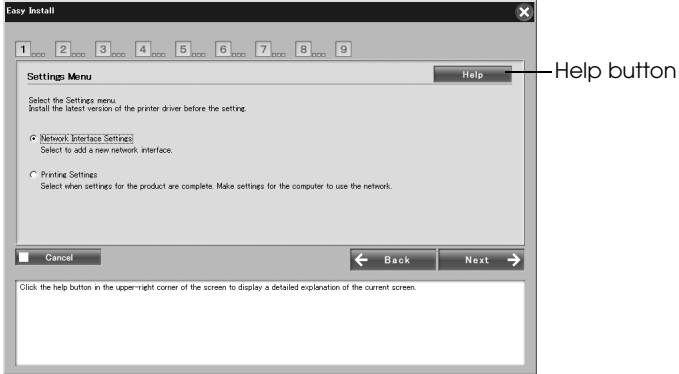

6. Select the setting method for the computer and network interface, and then click Next.

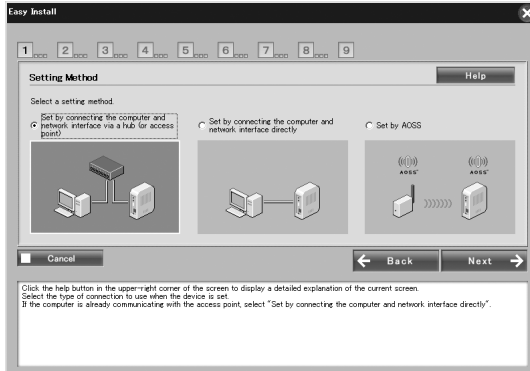

7. Follow the instructions on the screen to connect the cable to the network interface and then to turn it on.

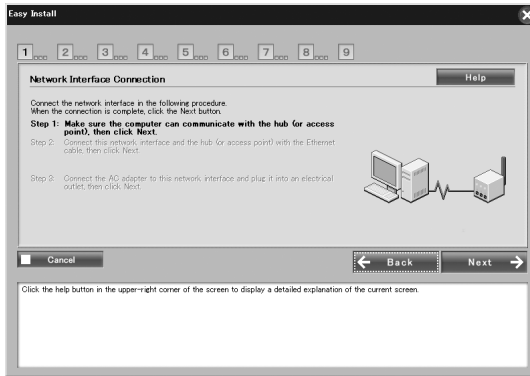

**Note:**

*If the Windows Security Alert screen appears, click the Unblock button; otherwise the device is not listed on the screen of Easy Install.*

8. Select the target device on which the network interface is installed, and then click Next.

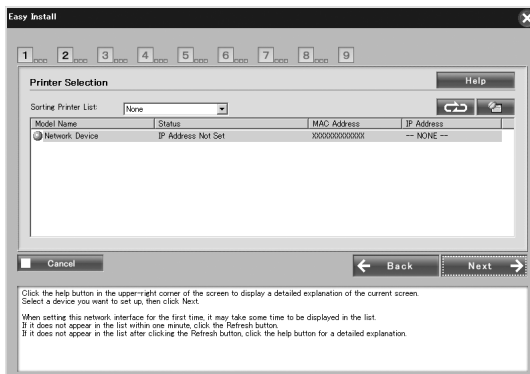

**Note:**

- ❑ *If you want to search for the target device again, click the  button.*
  
  - ❑ *Changing Sorting Method will change the sorting method for devices displayed on screen.*
9. Click Next to configure the wireless settings.  
If you do not want to configure the wireless settings, click Skip and go to step 12.

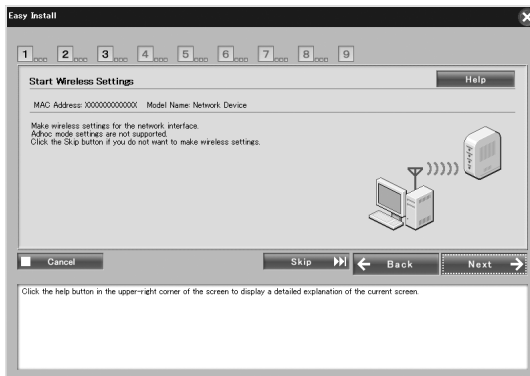

10. Select SSID from the drop-down list, and then click Next.

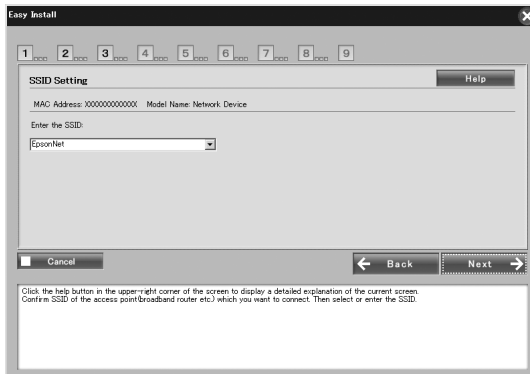

11. Select the security mode, and then click Next.

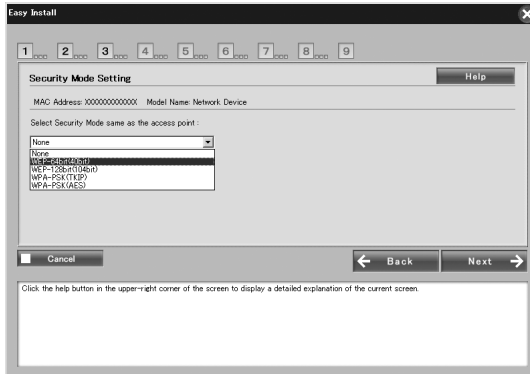

When you select WEP-64 bit (40 bit) or WEP-128 bit (104 bit), the WEP Key Settings screen appears. Enter the WEP Keys settings, and then click Next.

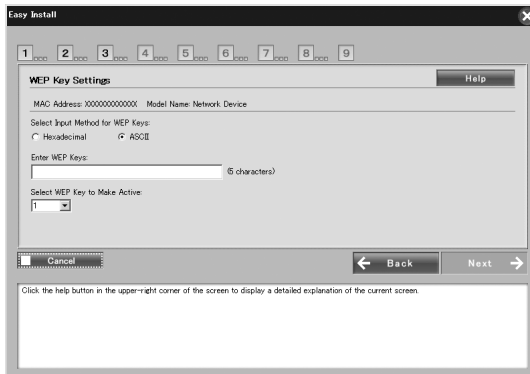

When you select WPA-PSK (TKIP) or WPA-PSK (AES), the WPA Configuration screen appears. Enter the password twice, and then click Next.

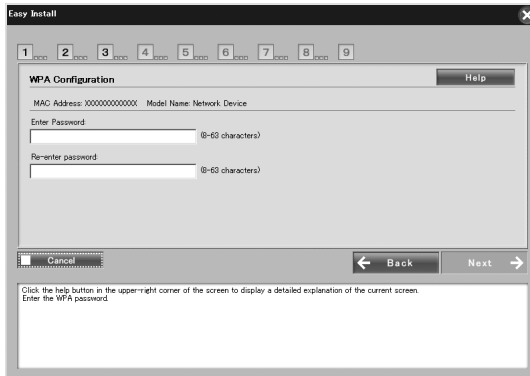

12. Click Next to set an IP address.  
If you do not want to set an IP address, click Skip and go to step 14.

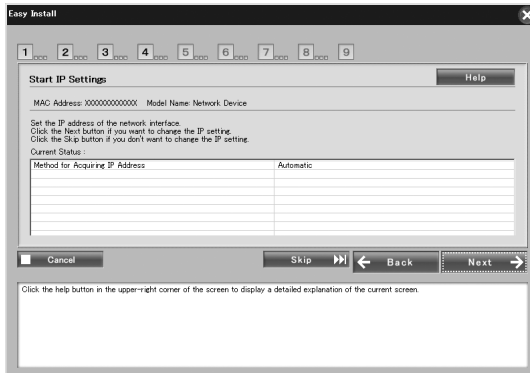



13. Select Automatic or Manual to assign the IP address to the network interface.

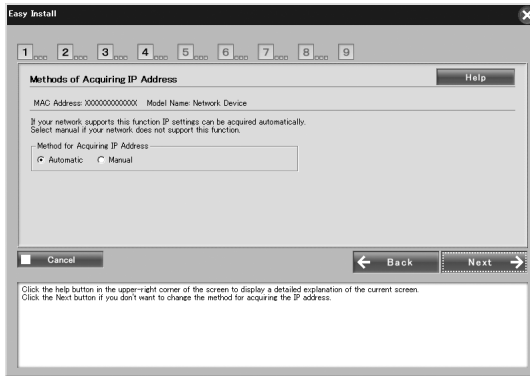

When you select Manual, you must enter the IP address, subnet mask, and default gateway. And then click Next.

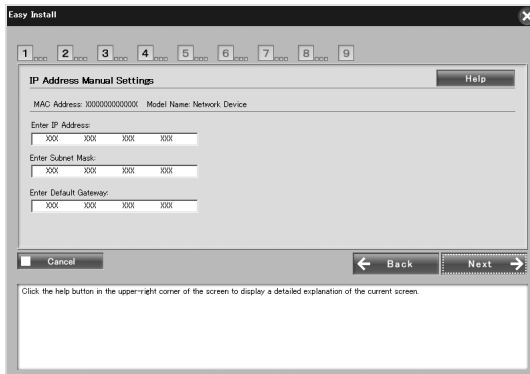

- For Macintosh, set the AppleTalk entity type and click Next. For Windows, skip this step and go to step 15.

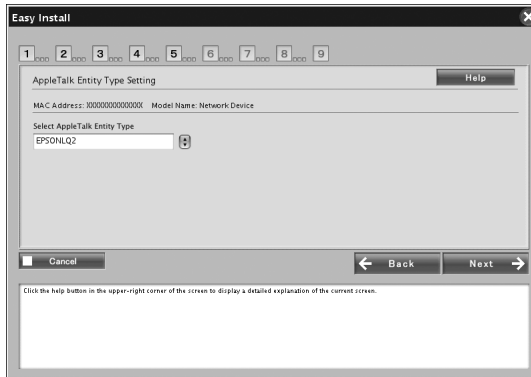

**Note:**  
*For the AppleTalk entity type appropriate for your printer or all-in-one, see “Supported Epson Devices” on page 8.*

- Confirm the settings you selected in the previous dialog box, and then click Next.

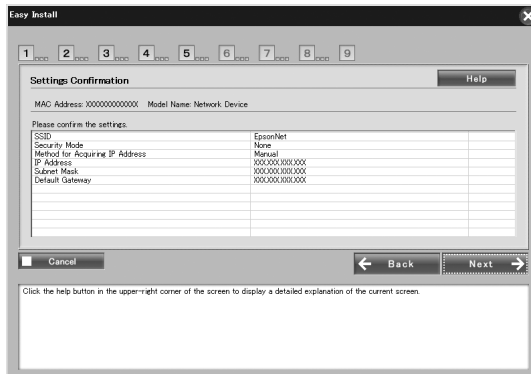

**Note:**  
*When the password screen appears, input the login password for the computer.*

16. When the setting transmission is completed, select the network interface connection.

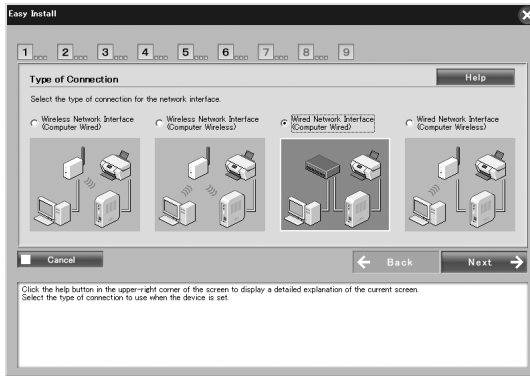

17. Follow the instructions on the screen to connect the cable to the printer or all-in-one and then to turn it on.

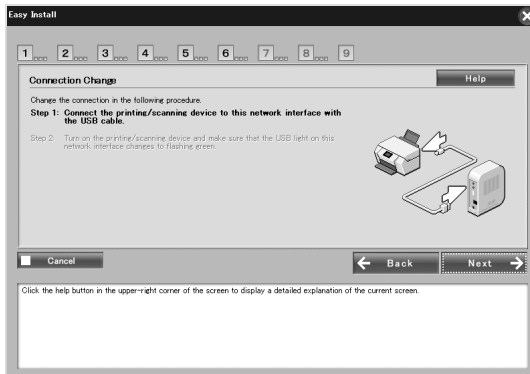

18. Click Next to change the memory card access settings.  
If you do not want to change the settings, click Skip and go to step 21.

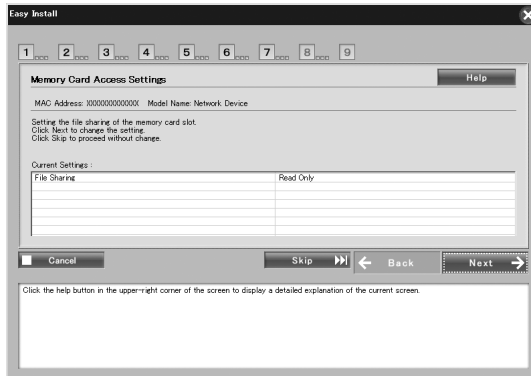

**Note:**  
*If the connected printer or all-in-one does not have memory slots, the steps 18 to 20 are automatically skipped.*

19. Select the access Settings right of the memory slots in the printer or all-in-one, and then click Next.

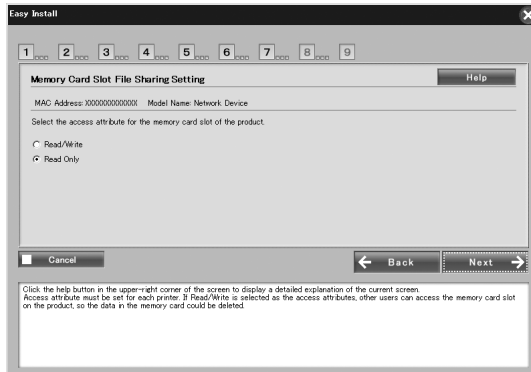

20. Confirm the settings you selected in the previous dialog box, and then click **Next**.

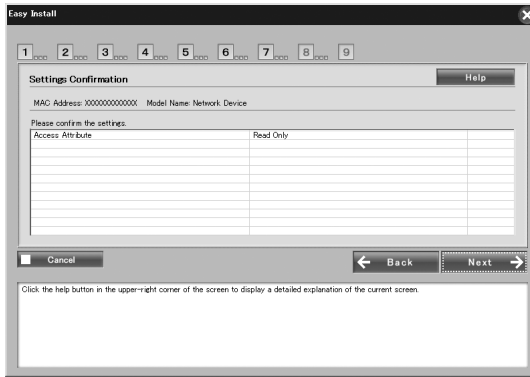

21. If the installation is complete, the Complete Setting network I/F screen appears. Click **Skip** to finish the installation. If you want to set up the computer for printing and scanning, click **Next** and go to “Setting for printing and scanning (Windows)” on page 30.

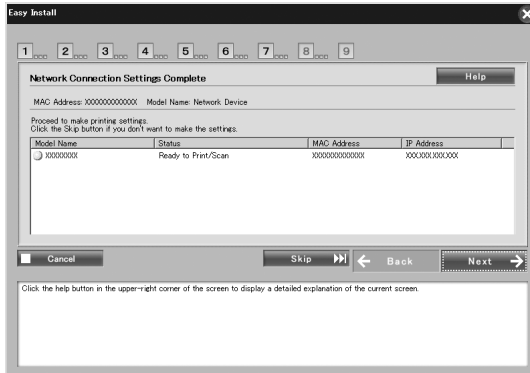

If the installation fails, an error message appears. If an error message appears, read the content of the message and try again.

**Note:**

*If your printer or all-in-one connected to this network interface has a memory card slot, unplug the network interface's AC adapter from the electrical outlet after completing setup, and then plug it back in to enable the Access Attribute setting for the memory card slot.*

**Note for Macintosh users:**

*You cannot set up the computer for printing and scanning with this software. See "Setting up the printer (Macintosh)" on page 32 and "Scanning via a network" on page 33 to set up the computer.*

## Setting for printing and scanning (Windows)

You can set up the computer for printing and scanning. The procedures below appear automatically after the network interface is configured.

1. Enter the printer name and select the Set as default printer check box if necessary, and then Click Next.



2. Follow the instructions on the screen to install the necessary applications, and then click Next.

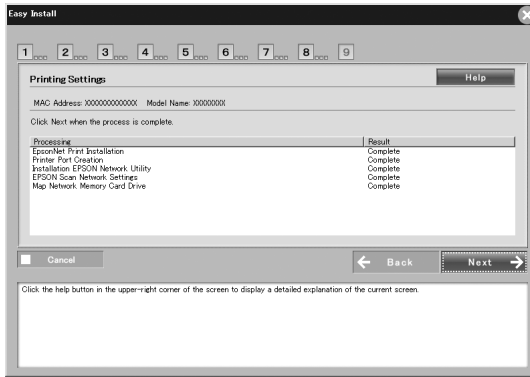

3. If you want to print the test page, click Yes, otherwise select No. Then click Next.



4. Click Next to complete the configuration.

**Note:**

- ❑ *If the installation fails, an error message will be displayed. If an error message appears, read the content of the message and try again.*

- *If the error message indicating the port is invalid appears in the test print, restart the computer after the settings are complete and print the test page from the printer's property's window.*

## **Setting up the printer (Macintosh)**

The printer driver must be installed on the computer before you can set up the printer. See the device's manual for information on installing the printer driver.

### **Mac OS X**

1. Open the Applications folder.
2. Open the Utilities folder.
3. Open Print Center (for Mac OS X 10.2 or below) or Printer Setup Utility (for Mac OS X 10.3 or later), and then click Add.
4. For Mac OS X 10.4, select the printer model that is connected with Bonjour.  
For Mac OS X 10.2 or 10.3, select Rendezvous from the drop down list, and then select the printer model from the list.

#### **Note:**

*For Mac OS X 10.4, if your printer is not displayed with the desired connection, click More Printers, select the desired connection from the drop down list, and then select the printer model.*

5. Click Add.

### **Mac OS 9**

1. Open Chooser from the Apple menu.
2. Click the printer icon.
3. Select the zone containing the printer.



4. Select the printer name from the list.
5. Make sure AppleTalk is active.
6. Close Chooser.

Now you can use the device on the network.

---

## ***Using the device***

### ***Scanning via a network***

You can scan images via a network. For details on the scanning function, see the documentation shipped with your device or the online help for EPSON Scan.

***Note:***

- ❑ *If the network connection is interrupted while starting up EPSON Scan, quit EPSON Scan and restart it after a short time. If you cannot restart EPSON Scan, turn the all-in-one off and on once and then restart EPSON Scan.*
- ❑ *Windows Server 2003 and Windows NT4.0 does not support this function.*

### ***Making settings for EPSON Scan***

1. **Windows**

Click Start, point to All Programs (for Windows Vista/XP users) or Programs (for Windows Me/98/2000 users) and EPSON Scan, and then select EPSON Scan Settings.

## Mac OS X

Double-click the Macintosh HD icon. In the Applications folder, double-click the Utilities folder. Then double-click the EPSON Scan Settings icon.



EPSON Scan Settings

## Mac OS 9

Click the Apple menu, point to Control Panels, and then select EPSON Scan Settings.

The EPSON Scan Settings dialog box appears.

2. Select the model of your device from the Select Scanner drop-down list.
3. Select the Network radio button.

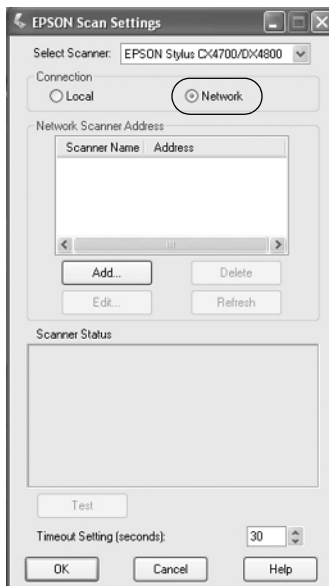

4. Click Add button, then Add screen appears. Select the IP address and click OK button.



5. Click the Test button on the EPSON Scan Settings screen. Make sure the device in the Scanner Status text box is available for use on the network.



**Note:**

*If the network connection fails, see EPSON Scan Troubleshooting Assistant.*

6. Click OK.

## **Starting EPSON Scan**

### **Windows**

Click Start, point to All Programs (for Windows Vista/XP users) or Programs (for Windows Me/98/2000 users) and EPSON Scan, and then select EPSON Scan.

### **Mac OS X**

Double-click the Macintosh HD icon. In the Applications folder, double-click the EPSON Scan icon.

### **Mac OS 9**

From the Apple menu, select EPSON Scan.

The EPSON Scan screen appears.

### **Note:**

- ❑ *If EPSON Scan does not start, see "Making settings for EPSON Scan" on page 33 for details.*
- ❑ *You cannot use the Scan to PC function and Scan to PDF function when scanning via a network.*

## Getting information through the online help

EPSON Scan has an online help that provides you with instructions on scanning and making driver settings.

Click Help in any of the dialog boxes in EPSON Scan.

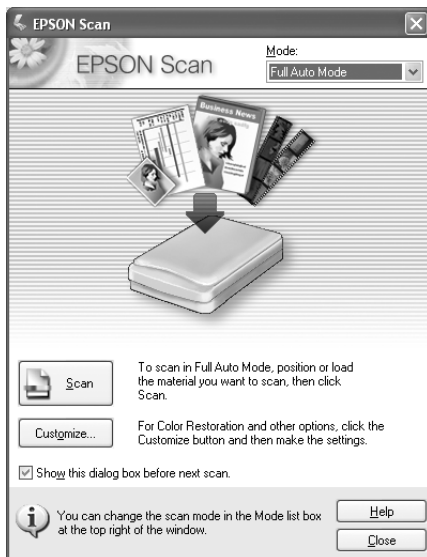

## Using the network for storage (Windows only)

You can display, read, or write data on the memory card via a wireless network.

### Note:

- ❑ You can use this function on Windows Vista, XP, Me, 98SE, 2000, Server 2003 only.
- ❑ You can specify the access right for network storage during the setup procedure on EpsonNet Easy Install. See "Configuring the network interface" on page 18 for details.

## Accessing the network storage

The network drive you mapped appears in My Computer. To display or read the file, double-click the network drive icon.

### Note:

*When the network drive does not appear in My Computer, connect it manually as follows.*

1. Run EpsonNet Config. Select Basic under MS Network, and then check the host name.

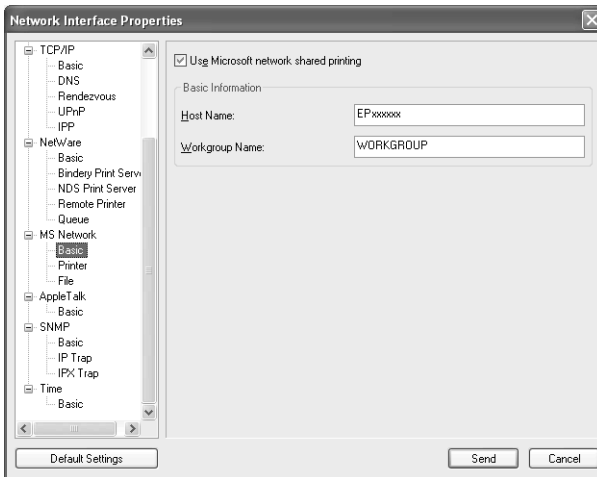

2. From the Start menu, select Run.

3. Enter the host name you checked in step 1, and then click OK.  
\\the host name of the MS Network\

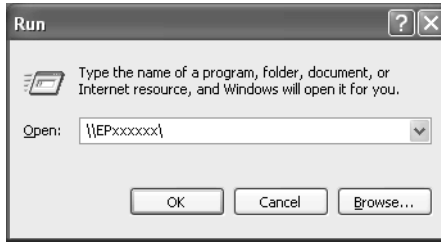

4. Right-click the MEMORYCARD icon, and then select Map Network Drive.

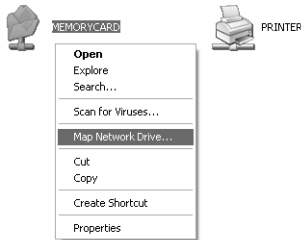

5. Specify the drive letter for the connection. We recommend that you select the Reconnect at logon check box. You can access Network Storage whenever you start the computer.

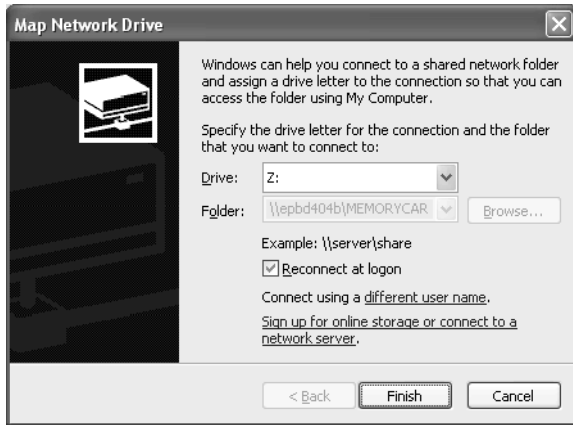

6. Click Finish.
7. The network drive you mapped appears in My Computer. To display or read the file, double-click the network drive icon.

## ***Disconnecting the network storage***

To disconnect the network drive of the network storage, right-click the network drive icon, and then select Disconnect.

## ***Changing the network storage information***

You can change the host name or the storage name you specified in the Run dialog box. You can also change the permissions on the network storage. For detailed information, see *EpsonNet Config Reference Guide*.



## Restrictions on EPSON Status Monitor

The operation of EPSON Status Monitor is different, depending on whether the printer or all-in-one is connected to the network interface for use in the wireless LAN environment or to the computer directly, as described below.

### ***For the ink jet printer or all-in-one***

The operation of the printer or all-in-one connected directly to the computer as a shared printer is the same as that connected to the wireless LAN.

#### ***Note:***

*The following explanation uses screen images of Windows XP. The screen images are the same for Macintosh.*

### *Cartridge information*

When the printer or all-in-one is connected via a wireless LAN, information may not be transmitted correctly. Because of this, all information may be displayed as “Unknown” even if you click the Information button in the EPSON Status Monitor dialog box.



## Connected to the computer directly

Cartridge Information				
Manufacturer:	INKbyEPSON	INKbyEPSON	INKbyEPSON	INKbyEPSON
Ink type:	<input checked="" type="radio"/> Black	<input type="radio"/> Cyan	<input type="radio"/> Magenta	<input type="radio"/> Yellow
Cartridge type:	High Yield	Standard Capacity	Standard Capacity	Standard Capacity
Cartridge code:	T0431	T0442	T0443	T0444
Production date:	2003/04	2003/04	2003/04	2003/04
<input type="button" value="OK"/>				

## Connected to the wireless LAN

Cartridge Information				
Manufacturer:	Unknown	Unknown	Unknown	Unknown
Ink type:	Unknown	Unknown	Unknown	Unknown
Cartridge type:	Unknown	Unknown	Unknown	Unknown
Cartridge code:	Unknown	Unknown	Unknown	Unknown
Production date:	Unknown	Unknown	Unknown	Unknown
<input type="button" value="OK"/>				

## Available number of printed sheets

When some of the ink becomes less than half, the available number of printed sheets appears if the printer or all-in-one is connected directly to the computer. However, this information does not appear if the printer or all-in-one is connected with the wireless LAN.

### Connected to the computer directly



### Connected to the wireless LAN



## *Error for paper-out or paper jammed*

When the paper has run out or is jammed, the Continue button appears if the printer or all-in-one is connected directly to the computer. However, this information does not appear if the printer or all-in-one is connected to the wireless LAN. Follow the on-screen instructions to clear the error.

### Connected to the computer directly

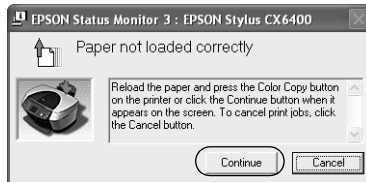

### Connected to the wireless LAN

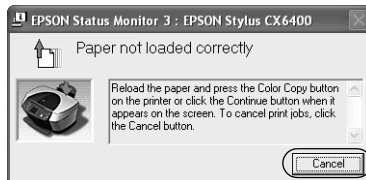

## *Ink replacement utility*

If the printer or all-in-one is connected directly to the computer, the Ink Replacement Utility dialog box appears when the ink has run out. When you click the OK button, the print head moves to the ink cartridge replacement position. On the other hand, if the printer or all-in-one is connected to the wireless LAN, you need to press the button on the printer or all-in-one to move the print head. Follow the on-screen instructions to replace the ink cartridge.

### Connected to the computer directly

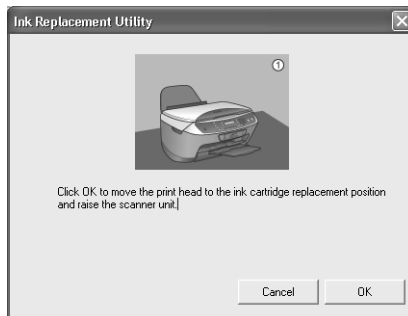

### Connected to the wireless LAN

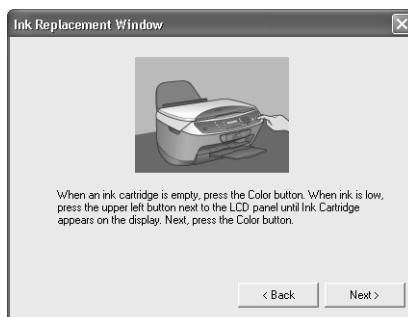

## Cancel printing when an error occurs

When the printer error dialog box appears and then you click the Cancel button, printing is canceled if the printer or all-in-one is connected directly to the computer. However, printing is not canceled if the printer or all-in-one is connected to the wireless LAN. Follow the on-screen instructions to clear the error first, and then see steps 1 to 3 below if you are using Windows, or step 3 only if you are using Macintosh.

1. For Windows Vista, click the Start menu, click Control Panel, and then click Printer.  
For Windows XP, click the Start menu, point to Control Panel, select Printers and Other Hardware, and then select Printers and Faxes.  
For Windows Me/98SE/2000, click the Start menu, point to Settings, and then select Printers.
2. Double-click the printer icon for which you want to cancel printing.
3. Click the print data. From the Document menu, select Cancel.  
For Windows Me/98SE, select Cancel Printing from the Document menu.

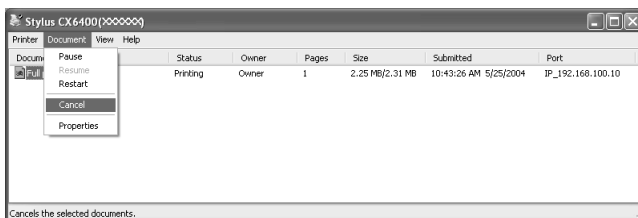

4. Turn off the printer, and then turn it back on after a while.

## ***For the laser printer***

### *For Windows XP Service Pack 2 Users*

If you share the laser printers on the computer running Windows XP Service Pack 2 on the network, client computers with the following conditions cannot monitor the printers using EPSON Status Monitor:

- Client computers running Windows Me/98/95
- Client computers located in another network segment

### *Solution*

1. Click Start, point to Control Panel, and then select Security Center. Click Windows Firewall.
2. Click the Exceptions tab, and then click the Add Program button.
3. Click the Browse button.
4. Select the program located in the following folder, using the Look in pull-down menu.

C:\Program Files\Common  
Files\EPSON\EBAPI\EEBAgent.exe

#### ***Note:***

*Substitute the drive letter for your operating system.*

5. Confirm that EEBAgent.exe is registered in the Programs list, and then click OK.
6. Confirm that the check box for EEBAgent.exe is selected in the Programs and Services list, and then click OK.

The Job Management function cannot be used (except in the wired LAN connection)

In the Monitoring Preferences dialog box, the Job Management setting does not appear. Therefore, the Job Information tab and the Notification message when your print job is finished dialog box do not appear.

**Note:**

*The models available on the market after 2004 are excluded.*