

**SC-S70600 Series**  
**SC-S50600 Series**  
**SC-S30600 Series**

**User's Guide**

---

## Copyrights and Trademarks

---

# Copyrights and Trademarks

No part of this publication may be reproduced, stored in a retrieval system, or transmitted in any form or by any means, electronic, mechanical, photocopying, recording, or otherwise, without the prior written permission of Seiko Epson Corporation. The information contained herein is designed only for use with this Epson printer. Epson is not responsible for any use of this information as applied to other printers.

Neither Seiko Epson Corporation nor its affiliates shall be liable to the purchaser of this product or third parties for damages, losses, costs, or expenses incurred by the purchaser or third parties as a result of accident, misuse, or abuse of this product or unauthorized modifications, repairs, or alterations to this product, or (excluding the U.S.) failure to strictly comply with Seiko Epson Corporation's operating and maintenance instructions.

Seiko Epson Corporation shall not be liable for any damages or problems arising from the use of any options or any consumable products other than those designated as Original Epson Products or Epson Approved Products by Seiko Epson Corporation.

Seiko Epson Corporation shall not be held liable for any damage resulting from electromagnetic interference that occurs from the use of any interface cables other than those designated as Epson Approved Products by Seiko Epson Corporation.

EPSON® is registered trademark, and EPSON EXCEED YOUR VISION or EXCEED YOUR VISION is a trademark of Seiko Epson Corporation.

Microsoft®, Windows®, and Windows Vista® are registered trademarks of Microsoft Corporation.

Apple®, Macintosh®, Mac OS®, and OS X® are registered trademarks of Apple Inc.

Intel® is a registered trademark of Intel Corporation.

PowerPC® is a registered trademark of International Business Machines Corporation.

Bemcot™ is a trademark of Asahi Kasei Corporation.

*General Notice: Other product names used herein are for identification purposes only and may be trademarks of their respective owners. Epson disclaims any and all rights in those marks.*

© 2012 Seiko Epson Corporation. All rights reserved.

## Contents

# Contents

## Copyrights and Trademarks

## Introduction

Important Safety Instructions. . . . .	5
When choosing a place for this product. . . . .	5
When setting up this product. . . . .	5
When using this product. . . . .	5
When handling the ink cartridges. . . . .	6
Notes on This Guide. . . . .	6
Meaning of Symbols. . . . .	6
Illustrations. . . . .	6
Printer Parts. . . . .	7
Front section (SC-S70600 series, SC-S50600 series). . . . .	7
Front section (SC-S30600 series). . . . .	10
Inside (SC-S70600 series, SC-S50600 series). . . . .	13
Inside (SC-S30600 series). . . . .	15
Back. . . . .	16
LAN port. . . . .	17
Control panel. . . . .	19
Understanding the Display. . . . .	20
Features. . . . .	23
Realizing High Productivity. . . . .	23
High Print Quality. . . . .	23
Superior Ease of Use. . . . .	23
Notes on Usage and Storage. . . . .	24
Installation space. . . . .	24
Notes when using the printer. . . . .	24
Notes when not using the printer. . . . .	25
Notes on handling ink cartridges. . . . .	26
Handling Media. . . . .	27
Notes on Usage of Spot color Inks (SC-S70600 series, SC-S50600 series). . . . .	27
Using the Supplied Software. . . . .	29
Contents of the Software Disc. . . . .	29
Starting EPSON LFP Remote Panel 2. . . . .	30
Exiting EPSON LFP Remote Panel 2. . . . .	30
Uninstalling Software. . . . .	30
<b>Basic Operations</b>	
Loading and Exchanging Media. . . . .	32
Positioning of the pressure rollers and media (SC-S70600 series, SC-S50600 series). . . . .	33
Loading Media (SC-S70600 series, SC-S50600 series). . . . .	36

Loading Media (SC-S30600 series). . . . .	48
Viewing and Changing Media Settings. . . . .	59
Exchanging Media. . . . .	60
Using the Auto Take-up Reel Unit. . . . .	62
Media Loading. . . . .	62
Counterweight Loading. . . . .	67
Removing the Take-up Roll. . . . .	67
Before Printing. . . . .	69
Saving Optimal Settings for the Current Media (Print Media Settings). . . . .	69
Parameters Stored in Media Setting Banks. . . . .	69
Recommended values for leading media types . . . . .	70
Saving Settings. . . . .	70
Changing Heater and Fan Settings. . . . .	75
Head Alignment (Manual Adjustment). . . . .	75
Feed Adjustment (Manual Feed Adjustment). . . . .	77
Using a Test Pattern. . . . .	78
Performing Feed Adjustment During Printing . . . . .	79
Printable area. . . . .	80
SC-S70600 series/SC-S50600 series. . . . .	80
SC-S30600 series. . . . .	82

## Maintenance

Maintenance types and frequency. . . . .	85
Regular Cleaning. . . . .	85
Replacing Consumables. . . . .	86
Other maintenance. . . . .	86
Preparation and Notes. . . . .	88
What You'll Need. . . . .	88
Notes on Cleaning. . . . .	88
Moving the Print Head. . . . .	89
Using Ink Cleaner. . . . .	89
Regular Cleaning. . . . .	90
Cleaning Around the Print Head. . . . .	90
Cleaning Around Caps. . . . .	91
Cleaning Inside the Printer. . . . .	96
Cleaning the Flushing Pad. . . . .	98
Regular Cleaning Check Sheet. . . . .	99
Replacing Consumables. . . . .	101
Replacement and Shake of Ink Cartridges. . . . .	101
Disposing of Waste Ink. . . . .	102
Replacing the Wiper and Wiper Cleaner. . . . .	104
Replacing the Flushing Pad. . . . .	105

## Contents

Disposal of used consumables. . . . .	106
Consumable Replacement Check Sheet. . . . .	107
Other maintenance. . . . .	109
Checking for clogged nozzles. . . . .	109
Head Cleaning. . . . .	110
Ink Circulation and Ink Refresh. . . . .	111
Long-term Storage (Pre-storage Maintenance) . . . . .	112
Parts That Are Periodically Replaced. . . . .	113

### Using the Control Panel Menu

Menu Operations. . . . .	114
Menu List. . . . .	115
Details of the Menu. . . . .	120
The Media Setup Menu. . . . .	120
Printer Setup Menu. . . . .	124
The Maintenance Menu. . . . .	127
The Ink Level Menu. . . . .	129
The Print Logs Menu. . . . .	129
The Printer Status Menu. . . . .	129
The Network Setup Menu. . . . .	129
The Preference Menu. . . . .	130
The Reset All Settings Menu. . . . .	131

### Problem Solver

When a Message is Displayed. . . . .	132
When a Maintenance Call/Service Call Occurs. . . . .	134
Troubleshooting. . . . .	135
You cannot print (because the printer does not work). . . . .	135
The printer sounds like it is printing, but nothing prints. . . . .	135
The prints are not what you expected. . . . .	136
Media. . . . .	142
Others. . . . .	143

### Appendix

Options and Consumable Products. . . . .	145
Supported Media. . . . .	149
Moving and Transporting the Printer. . . . .	149
Moving the Printer. . . . .	149
Transport. . . . .	150
Microweave (M/W) setting and banding association table. . . . .	151
System Requirements. . . . .	153
Specifications Table. . . . .	153
Standards and Approvals. . . . .	154

### Where To Get Help

Technical Support Web Site. . . . .	156
Contacting Epson Support. . . . .	156
Before Contacting Epson. . . . .	156
Help for Users in North America. . . . .	157
Help for Users in Europe. . . . .	157
Help for Users in Australia. . . . .	157
Help for Users in Singapore. . . . .	158
Help for Users in Thailand. . . . .	158
Help for Users in Vietnam. . . . .	158
Help for Users in Indonesia. . . . .	158
Help for Users in Hong Kong. . . . .	159
Help for Users in Malaysia. . . . .	159
Help for Users in India. . . . .	159
Help for Users in the Philippines. . . . .	160

### Software License Terms

Open Source Software Licenses. . . . .	161
Bonjour. . . . .	161
Other Software Licenses. . . . .	166
Info-ZIP copyright and license. . . . .	166

## Introduction

# Introduction

## Important Safety Instructions

Read all of these instructions before using the printer. Also be sure to follow all warnings and instructions marked on the printer.

### When choosing a place for this product

- ❑ Place this product on a flat, stable surface that is larger than this product. This product will not operate properly if it is tilted or at an angle.
- ❑ Avoid places subject to rapid changes in temperature and humidity. Also keep it away from direct sunlight, strong light, or heat sources.
- ❑ Avoid places subject to shocks and vibrations.
- ❑ Keep this product away from dusty areas.
- ❑ Place this product near a wall outlet where the plug can be easily unplugged.

### When setting up this product

- ❑ This product's power cord is for use with this product only. Use with other equipment may result in fire or electric shock.
- ❑ Connect all equipment to properly grounded power outlets. Avoid using outlets on the same circuit as copiers or air control systems that regularly switch on and off.
- ❑ Avoid electrical outlets controlled by wall switches or automatic timers.
- ❑ Keep the entire computer system away from potential sources of electromagnetic interference, such as loudspeakers or the base units of cordless telephones.
- ❑ Use only the type of power source indicated on the product's label.

- ❑ Use only the power cord that comes with this product. Use of another cord may result in fire or electric shock.
- ❑ Do not use a damaged or frayed power cord.
- ❑ If you use an extension cord with this product, make sure the total ampere rating of the devices plugged into the extension cord does not exceed the cord's ampere rating. Also, make sure the total ampere rating of all devices plugged into the wall outlet does not exceed the wall outlet's ampere rating.
- ❑ If you plan to use the printer in Germany, observe the following:

To provide adequate short-circuit protection and over-current protection for this printer, the building installation must be protected by a 10 or 16 amp circuit breaker.

- ❑ If damage occurs to the plug, replace the cord set or consult a qualified electrician. If there are fuses in the plug, make sure you replace them with fuses of the correct size and rating.

### When using this product

- ❑ Do not block or cover the openings in this product's cabinet.
- ❑ Do not insert objects through the slots. Take care not to spill liquid on this product.
- ❑ Do not attempt to service this product yourself.
- ❑ Unplug this product and refer servicing to qualified service personnel under the following conditions: The power cord or plug is damaged; liquid has entered the product; the product has been dropped or the cabinet damaged; the product does not operate normally or exhibits a distinct change in performance.
- ❑ Do not move the print heads by hand; otherwise you may damage this product.
- ❑ Always turn the product off using the Power button on the control panel. When this button is pressed, the Power light flashes briefly then goes off. Do not unplug the power cord or turn off the product until the Power light stops flashing.

## Introduction

- ❑ This device has two power systems. There is a risk of electric shock unless the two power cables are unplugged during the maintenance.

---



### When handling the ink cartridges

- ❑ Keep ink cartridges out of the reach of children and do not drink.
- ❑ Do not touch the green IC chip on the side of the cartridge. This may affect normal operation and printing.
- ❑ The IC chip on this ink cartridge retains a variety of cartridge-related information, such as the ink cartridge status, so that the cartridge may be removed and reinserted freely.
- ❑ If you remove an ink cartridge for later use, protect the ink supply area from dirt and dust, and store it in the same environment as this product. Note that there is a valve in the ink supply port, making covers or plugs unnecessary, but care is needed to prevent the ink from staining items that the cartridge touches. Do not touch the ink supply port or surrounding area.

## Notes on This Guide

---

### Meaning of Symbols

 <b>Warning:</b>	Warnings must be followed to avoid serious bodily injury.
 <b>Caution:</b>	Cautions must be followed to avoid bodily injury.
 <b>Important:</b>	Important must be followed to avoid damage to this product.
<b>Note:</b>	Notes contain useful or additional information on the operation of this product.

---

## Illustrations

Unless otherwise noted, the illustrations in this manual show the SC-S30600 series.

## Introduction

# Printer Parts

## Front section (SC-S70600 series, SC-S50600 series)

The illustration shows the SC-S50600 series.

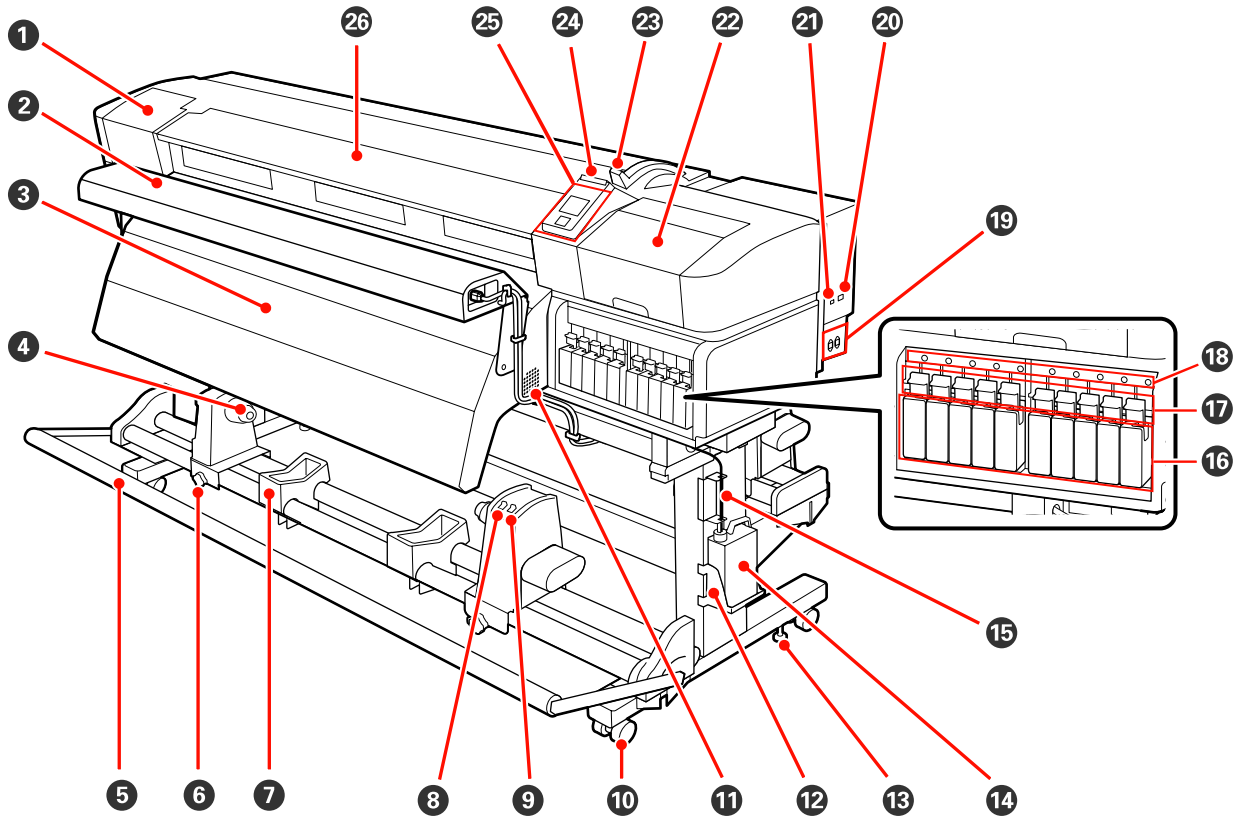

**1 Maintenance cover (left)**

Open this cover to clean the area around the print head. Normally closed when using the printer.

 [“Cleaning Around the Print Head” on page 90](#)

**2 Additional print drying system**

The additional print drying system can be used to rapidly dry ink after printing. Available separately for the SC-S70600 series.

 [Additional Print Drying System Setup Guide](#)

**3 After heater**

The heater can be used to rapidly dry ink after printing.

 [“Heating & Drying” on page 73](#)

**4 Roll core holder**

Place the used roll core for media take-up on these holders. There are two supports: one on the left and one on the right.

 [“Media Loading” on page 62](#)

## Introduction

### 5 Tensioner

The tensioner maintains tension to prevent the media sagging as it is taken up.

### 6 Roll core holder locking screw

The locking screws keep the roll core holders in place once they have been attached to the roll core. There are same parts on both the left and the right.

### 7 Roll support

Rest media temporarily on these supports when removing the take-up roll. There are two supports: one on the left and one on the right.

### 8 Auto switch

Use this switch to select the auto take-up direction. Choose Off to disable auto take-up.

### 9 Manual switch

Use this switch to select the manual take-up direction. The selected option takes effect when the Auto switch is in the Off position.

### 10 Casters

There are two casters on each leg. Once installation is complete, the front casters should be kept locked while the printer is in use.

### 11 Airflow vents

These vents vent air from inside the printer. Do not obstruct these vents.

### 12 Waste ink bottle holder

Place the waste ink bottle in this holder.

### 13 Adjuster

The adjusters keep the printer in place. After installing the printer, keep it securely in place during use.

### 14 Waste ink bottle

Waste ink collects in this bottle.

Replace with a new waste ink bottle when the level approaches the line.

### 15 Waste ink tube

Waste ink is discharged from this tube. Be sure the end of this tube is in the waste ink bottle while the printer is in use.

### 16 Ink cartridge/replacement cartridge

The number of each type of cartridge installed varies with the option selected for color mode.

SC-S70600 series: 8 colors/10 colors

SC-S50600 series: 4 colors/5 colors

In 8 or 4 color mode, use replacement cartridges as well to fill all slots.

### 17 Lock levers

Raise the levers to unlock the ink cartridges prior to removal. Lower the levers to lock the cartridges in place after insertion.

### 18 Cartridge check lamp

This lamp lights when an ink cartridge error occurs.



## Introduction

On : An error occurred. Check the contents of the error on the control panel's screen.

Off : No error.

**19 AC inlet #1/AC inlet #2**

Connects the power cable. Be sure to connect both cables.

**20 LAN port**

 [“LAN port” on page 17](#)

**21 USB port**

Connects the USB cable.

**22 Maintenance cover (right)**

Open this cover when performing regular maintenance. Normally closed when using the printer.

 [“Regular Cleaning” on page 90](#)

**23 Media loading lever**

After loading media, lower the media loading lever to keep the media in place. Raise the lever to release the media prior to removal.

**24 Alert lamp**

This lamp lights or flashes when an error occurs.

On : An error occurred; the type of error is indicated by how the lamp lights or flashes. Check the  
Flashing contents of the error on the control panel's screen.

Off : No error.

**25 Control panel**

 [“Control panel” on page 19](#)

**26 Front cover**

Open when loading media, cleaning the inside of the printer, or removing jammed media. Normally closed when using the printer.

## Introduction

## Front section (SC-S30600 series)

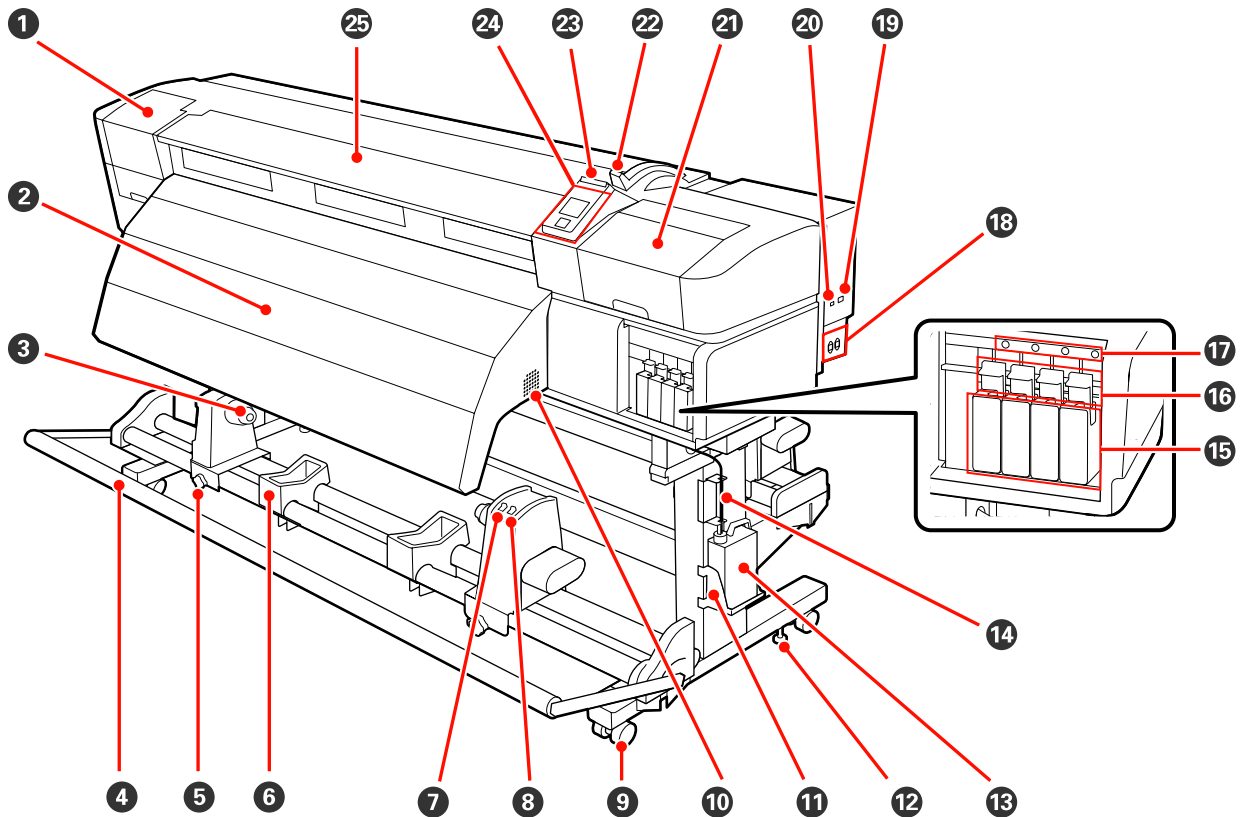
**1 Maintenance cover (left)**

Open this cover to clean the area around the print head. Normally closed when using the printer.

[“Cleaning Around the Print Head” on page 90](#)

**2 After heater**

The heater can be used to rapidly dry ink after printing.

[“Heating & Drying” on page 73](#)

**3 Roll core holder**

Place the used roll core for media take-up on these holders. There are two supports: one on the left and one on the right.

[“Media Loading” on page 62](#)

**4 Tensioner**

The tensioner maintains tension to prevent the media sagging as it is taken up.

**5 Roll core holder locking screw**

The locking screws keep the roll core holders in place once they have been attached to the roll core. There are same parts on both the left and the right.

**6 Roll support**

Rest media temporarily on these supports when removing the take-up roll. There are two supports: one on the left and one on the right.

## Introduction

### 7 Auto switch

Use this switch to select the auto take-up direction. Choose Off to disable auto take-up.

### 8 Manual switch

Use this switch to select the manual take-up direction. The selected option takes effect when the Auto switch is in the Off position.

### 9 Casters

There are two casters on each leg. Once installation is complete, the front casters should be kept locked while the printer is in use.

### 10 Airflow vents

These vents vent air from inside the printer. Do not obstruct these vents.

### 11 Waste ink bottle holder

Place the waste ink bottle in this holder.

### 12 Adjuster

The adjusters keep the printer in place. After installing the printer, keep it securely in place during use.

### 13 Waste ink bottle

Waste ink collects in this bottle.

Replace with a new waste ink bottle when the level approaches the line.

### 14 Waste ink tube

Waste ink is discharged from this tube. Be sure the end of this tube is in the waste ink bottle while the printer is in use.

### 15 Ink cartridges

Install all ink cartridges into each slot.

### 16 Lock levers

Raise the levers to unlock the ink cartridges prior to removal. Lower the levers to lock the cartridges in place after insertion.

### 17 Cartridge check lamp

This lamp lights when an ink cartridge error occurs.

On : An error occurred. Check the contents of the error on the control panel's screen.

Off : No error.

### 18 AC inlet #1/AC inlet #2

Connects the power cable. Be sure to connect both cables.

### 19 LAN port

 [“LAN port” on page 17](#)

### 20 USB port

Connects the USB cable.

## Introduction

### 21 Maintenance cover (right)

Open this cover when performing regular maintenance. Normally closed when using the printer.

 [“Regular Cleaning” on page 90](#)

### 22 Media loading lever

After loading media, lower the media loading lever to keep the media in place. Raise the lever to release the media prior to removal.

### 23 Alert lamp

This lamp lights or flashes when an error occurs.

On : An error occurred. the type of error is indicated by how the lamp lights or flashes. Check the  
Flashing contents of the error on the control panel's screen.

Off : No error.

### 24 Control panel

 [“Control panel” on page 19](#)

### 25 Front cover

Open when loading media, cleaning the inside of the printer, or removing jammed media. Normally closed when using the printer.

## Introduction

## Inside (SC-S70600 series, SC-S50600 series)

Dirt on any of the following parts may reduce print quality. Regularly clean or exchange these parts as described in the chapters listed in the reference sections below. The illustration shows the SC-S70600 series.

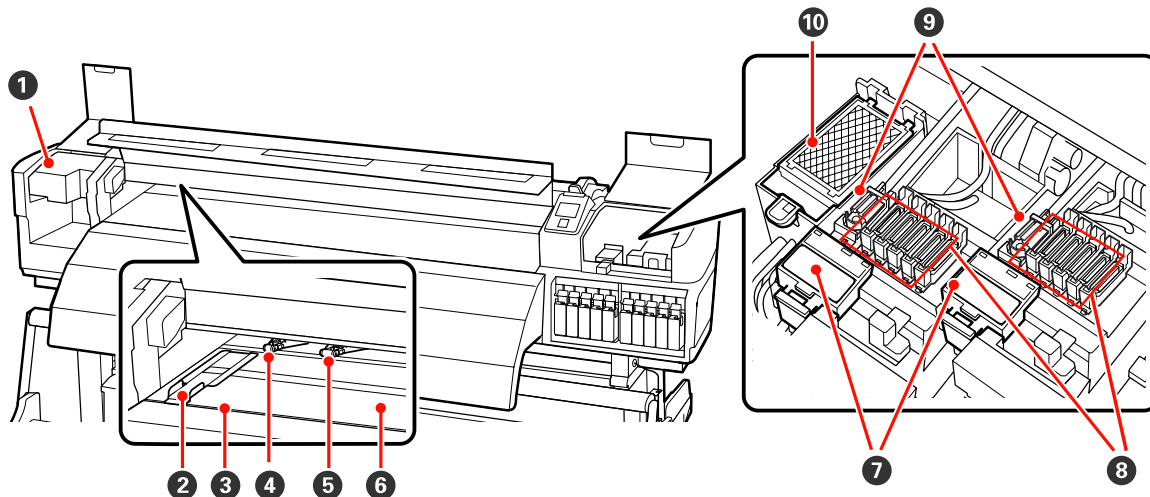

### 1 Print head

The print head prints by moving left and right while emitting ink. The print head on the left is “Head 1”, the print head on the right is “Head 2”. We recommend that you clean the area around this unit once a week.

[☞ “Cleaning Around the Print Head” on page 90](#)

### 2 Media holding plate

The media holding plates prevent the media riding up and keep fibers on the cut edge of the media from touching the print head. Position the plates at either side of the media before printing.

[☞ “Loading Media \(SC-S70600 series, SC-S50600 series\)” on page 36](#)

### 3 Cutter groove

Pass the blade of a cutter (available in the market) down this groove to cut media.

### 4 Pressure rollers (high)

There are ten rollers in total; the high pressure rollers are the two on the outside edges. They press down on the edges of the media when transparent film is used and during ink layering.

[☞ “Positioning of the pressure rollers and media \(SC-S70600 series, SC-S50600 series\)” on page 33](#)

Ink layering [☞ “High Print Quality” on page 23](#)

[☞ “Cleaning Inside the Printer” on page 96](#)

### 5 Pressure rollers (low)

There are ten rollers in total; all of which are low pressure rollers apart from the two on the outside edges. They press down on the media during normal printing (which excludes transparent film loading and ink layering). The number used varies with the width of the media.

[☞ “Cleaning Inside the Printer” on page 96](#)

## Introduction

### 6 Platen heater

The platen heater ensures that the ink adheres evenly.

 [“Heating & Drying” on page 73](#)

 [“Cleaning Inside the Printer” on page 96](#)

### 7 Wiper cleaner

The wiper cleaner removes ink from the wiper. It is a consumable; replace about once every six months.

 [“Replacing the Wiper and Wiper Cleaner” on page 104](#)

### 8 Caps

Except during printing, these caps cover the print head nozzles to prevent them drying out. We recommend that this unit be cleaned once a week.

 [“Cleaning Around Caps” on page 91](#)

### 9 Wiper

The wiper removes ink from the print head nozzles. We recommend that this unit be cleaned once a week. It is a consumable; replace about once every six months.

 [“Cleaning Around Caps” on page 91](#)

 [“Replacing the Wiper and Wiper Cleaner” on page 104](#)

### 10 Flushing pad

Ink is discharged onto this pad during flushing. It is a consumable; replace about once every six months.

 [“Replacing the Flushing Pad” on page 105](#)

## Introduction

## Inside (SC-S30600 series)

Dirt on any of the following parts may reduce print quality. Regularly clean or exchange these parts as described in the chapters listed in the reference sections below.

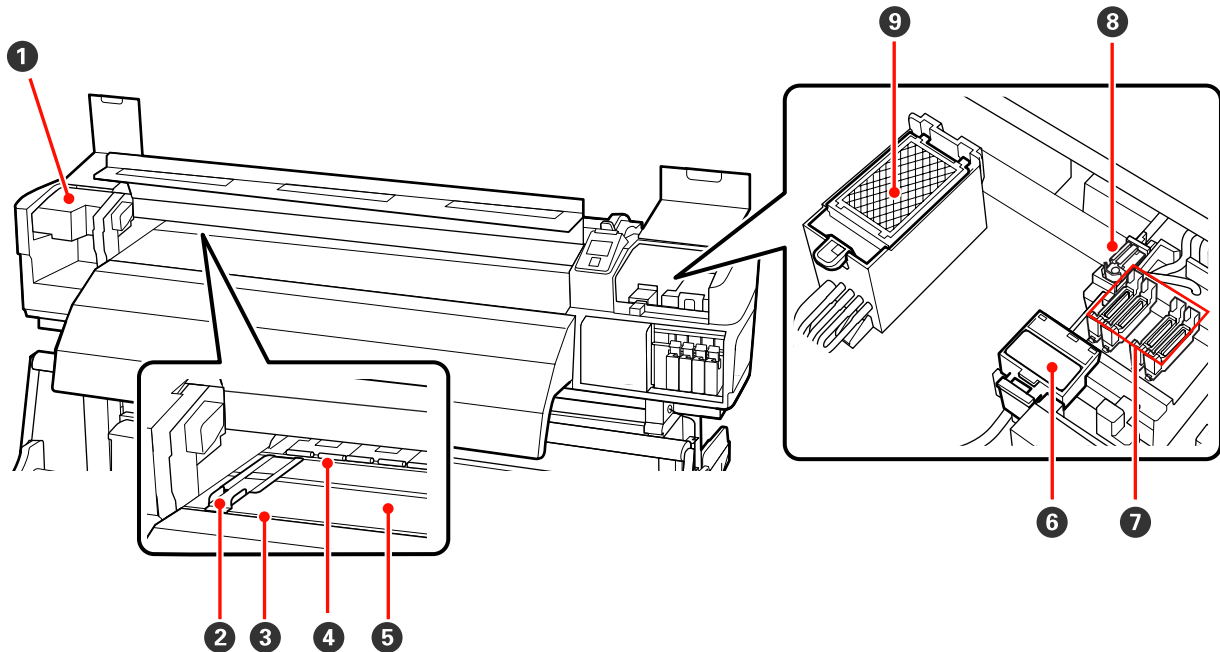

### 1 Print head

The print head prints by moving left and right while emitting ink. We recommend that you clean the area around this unit once a week.

[☞ “Cleaning Around the Print Head” on page 90](#)

### 2 Media holding plate

The media holding plates prevent the media riding up and keep fibers on the cut edge of the media from touching the print head. Position the plates at either side of the media before printing.

[☞ “Loading Media \(SC-S30600 series\)” on page 48](#)

### 3 Cutter groove

Pass the blade of a cutter (available in the market) down this groove to cut media.

### 4 Pressure rollers

These rollers press down on the media during printing.

[☞ “Cleaning Inside the Printer” on page 96](#)

### 5 Platen heater

The platen heater ensures that the ink adheres evenly.

[☞ “Heating & Drying” on page 73](#)

[☞ “Cleaning Inside the Printer” on page 96](#)

## Introduction

### 6 Wiper cleaner

The wiper cleaner removes ink from the wiper. It is a consumable; replace about once every six months.

 [“Replacing the Wiper and Wiper Cleaner” on page 104](#)

### 7 Caps

Except during printing, these caps cover the print head nozzles to prevent them drying out. We recommend that this unit be cleaned once a week.

 [“Cleaning Around Caps” on page 91](#)

### 8 Wiper

The wiper removes ink from the print head nozzles. We recommend that this unit be cleaned once a week. It is a consumable; replace about once every six months.

 [“Cleaning Around Caps” on page 91](#)

 [“Replacing the Wiper and Wiper Cleaner” on page 104](#)

### 9 Flushing pad

Ink is discharged onto this pad during flushing. It is a consumable; replace about once every six months.

 [“Replacing the Flushing Pad” on page 105](#)

---

## Back

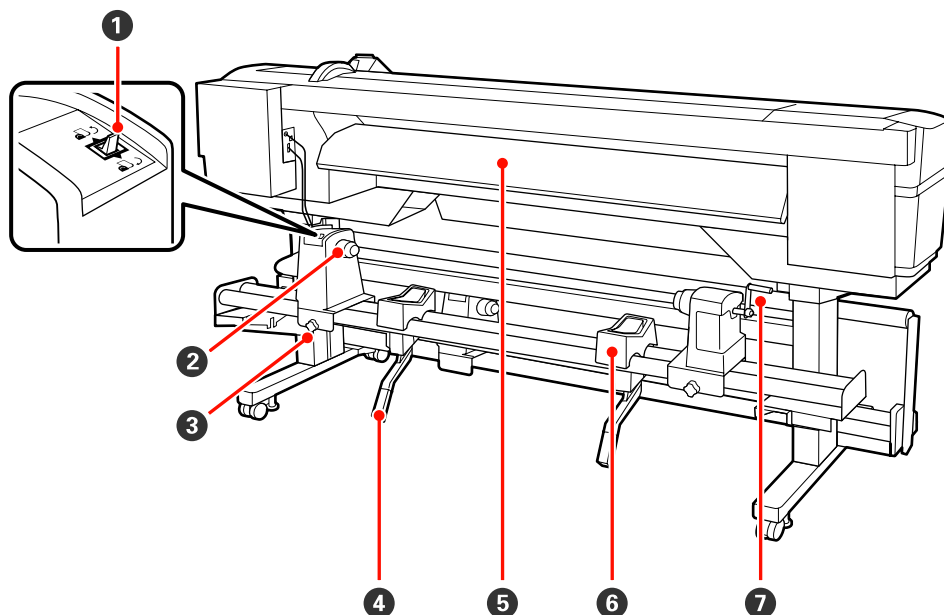

### 1 Drive switch

The drive switch is used to feed the media during loading and to rewind the media for replacement.

### 2 Roll holder

Place media on these holders. There are same parts on both the left and the right.



## Introduction

### ③ Roll holder fixing screw

These screws fix the roll holders in place once the media has been installed. There are same parts on both the left and the right.

### ④ Lift lever

If the media to be mounted on the roll holders seems heavy, use these levers to raise the media effortlessly to the level of the roll holders. There are same parts on both the left and the right.

### ⑤ Pre-heater

Heats the media before printing so that the print area is not subject to sudden changes in temperature.

### ⑥ Roll support

Rest media on these supports before placing it on the roll holders. There are same parts on both the left and the right.

### ⑦ Handle

After placing media on the right roll holder, rotate the handle to press the holder and apply pressure to the roll core.

---

## LAN port

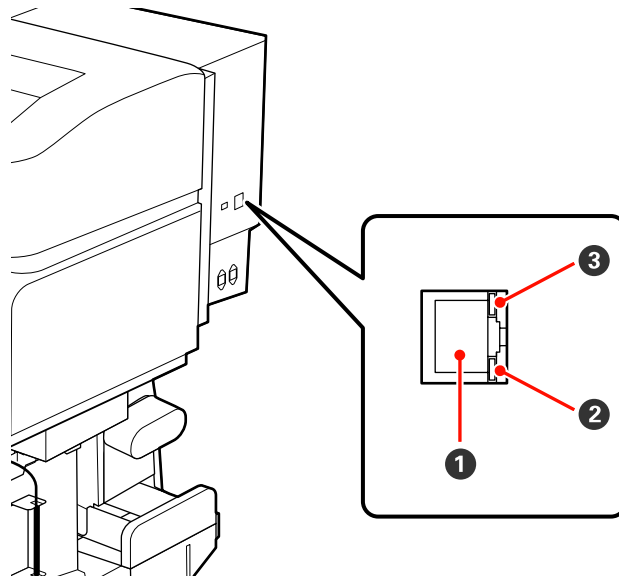

### ① RJ-45 connector

Connects the LAN cable. Use a shielded twisted pair cable (category 5 or higher).

### ② Data lamp

The data lamp shows connection status and indicates whether the printer is receiving data.

### ③ Status lamp (green/red)

The status lamp indicates network connection speed.

**Introduction**

Data lamp	Status lamp (green/red)	Status
On	On (green)	The printer is connected using a 1000base-T connection.
Flashing		The printer is receiving data over a 1000base-T connection.
On	On (red)	The printer is connected using a 100base-TX connection.
Flashing		The printer is receiving data over a 100base-TX connection.

## Introduction

## Control panel

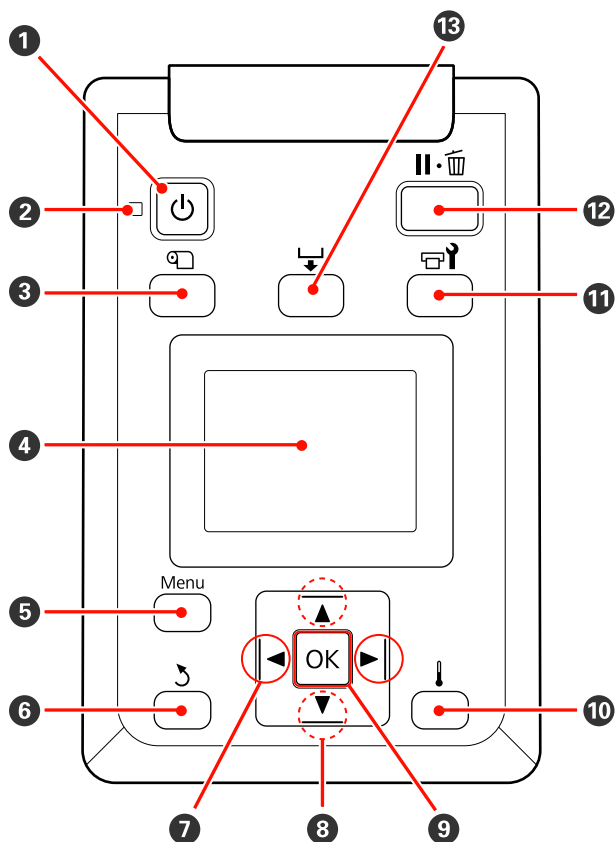
**1** **button (power button)**

Turns the power on and off.

**2** **light (power light)**

The printer's operational status is indicated by a lit or flashing light.

On : The power is on.

Flashing : The printer is receiving data or performing head cleaning or other operations during shut-down.

Off : The power is off.

**3** **button (media setup button)**

Press this button to display the Media Setup menu, which contains such items as **Media Remaining**, **Select Media**, **Customize Settings**, and **Print Media List**. This button is disabled during printing.

[“The Media Setup Menu” on page 120](#)

**4** **Display**

Displays the printer's status, menus, error messages, and so on. [“Understanding the Display” on page 20](#)

**5** **Menu button**

Press this button to display menus. [“Using the Control Panel Menu” on page 114](#)

**6** **Back button (back button)**

Press this button to exit to the previous menu when options are displayed. [“Menu Operations” on page 114](#)

**7** **Left and right arrow buttons (left and right arrow buttons)**

Use to position the cursor when performing such tasks as entering a **Setting Name** or **IP Address** in the setup menu.

**8** **Media feed buttons (media feed buttons)**

When the media loading lever is in a lowered position and the ▼ button is pressed, media is fed. If the ▲ button is pressed, media is rewound. This occurs regardless of the way the loaded media is rolled. If the ▼ button is pushed and held in a printable state at screens after adjustments or check pattern printing or at the media feed screen, media is fed a maximum of 103 cm. Keep the ▲ button pressed to rewind the media up to 25 cm.

Note that when the ▲ button is used to rewind, the media will stop when its edge reaches the starting print position. Rewind can be resumed by releasing the button and then pressing it again.

When the media loading lever in a raised position, the button to rewind media depends on how the loaded media is rolled.

Printable Side Out: Press the ▲ button.

Printable Side In: Press the ▼ button.

Keep the button pressed to rewind the media up to 25 cm.

When the menus are displayed, these buttons can be used to select menu items and options. [“Menu Operations” on page 114](#)

**9** **OK button**

Pressing this button when a menu item is highlighted displays options for the selected item.

Pressing this button when an option is highlighted selects the highlighted item or performs the selected operation.



## Introduction



- 10**  **button (heating and drying button)**  
 Pressing this button displays the Heating & Drying menu, where you can adjust the **Heater Temperature**. If the additional print drying system (supplied with the SC-S50600 series; optional with other models) is attached, you can also adjust **Additional Dryer** settings. These options can be adjusted during printing.

 [“The Media Setup Menu” on page 120](#)

- 11**  **button (maintenance button)**  
 Pressing this button displays the Maintenance menu, which contains such items as **Nozzle Check**, **Cleaning**, **Head Maintenance**, **Waste Ink Counter**, **Head Washing**, and **Pre-Storage Maint.**. This button is disabled during printing.

 [“The Maintenance Menu” on page 127](#)

- 12**  **button (pause/cancel button)**
- The printer enters pause status if this is pressed while printing. To release the pause status, press the  button again, or select **Pause Cancel** on the screen and then press the OK button. To cancel print jobs being processed, select **Job Cancel** on the screen and then press the OK button.
  - Pressing this button when menus are displayed closes the menus and returns the printer to ready status.

- 13**  **button (media feed button)**
- When the printer is in the ready state, you can feed the media to the cut position by pressing this button and then OK.  
 [“Cutting Media” on page 60](#)
  - When printing is in progress, you can use this button to adjust media feed.  
 [“Feed Adjustment \(Manual Feed Adjustment\)” on page 77](#)

## Understanding the Display

The illustration shows the display for the SC-S50600 series.

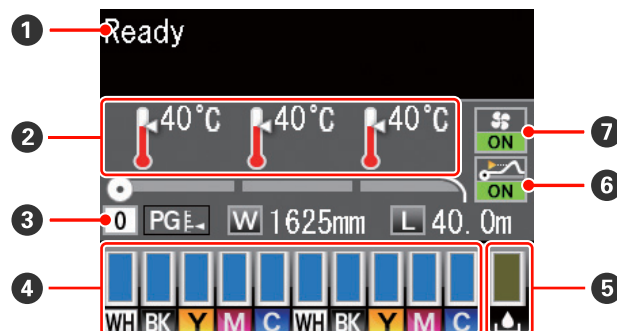

- 1 Messages**  
 Displays the printer's status, operation, and error messages.  
 [“When a Message is Displayed” on page 132](#)

- 2 Heater temperature**  
 From left to right, this display shows the temperature settings for the pre-heater, platen heater, and after heater. The thermometer icons give a rough indication of the current temperatures of the heaters.

 : The heater has reached the selected temperature.

 : The heater has not reached the selected temperature.

- 3 Media info**
- From left to right, this display shows the selected media, platen gap, media width, and media remaining.
  - If a media setting bank number created with this printer is selected as the print media, the number (from 1 to 30) will be displayed. When **RIP Settings** is selected, 0 will be displayed.

The selected platen gap is shown as follows.

 : 1.5

 : 2.0

 : 2.5

## Introduction

- ❑ The media remaining is not displayed if **Off** is selected for **Remaining Setup** in the **Media Remaining** menu.  
 ["The Media Setup Menu" on page 120](#)

### 4 Ink cartridge status

Displays the approximate level of remaining ink and the current status. When ink runs low or an error occurs, the display changes as shown below.



#### 1 Status indicators

The ink cartridge status is indicated as follows.

 : Ready to print. The height of the indicator changes with the level of ink remaining.

 : Ink is low. You need to prepare a new ink cartridge.

 : The level of ink remaining has reached the limit. Replace the old ink cartridge with a new one when using the SC-S30600 series or when not using spot color inks.

Replace the old ink cartridge with a new one promptly when using spot color inks. If the old cartridge is not replaced, the print head or other parts may be damaged.

 : The ink cartridge is not latched. Lower the lock lever to engage the latch.

 : No ink cartridge is inserted. Insert the ink cartridge and lower the lock lever to engage the latch.

 : An error occurred. Check the message on the screen, and clear the error.

 : A Cleaning cartridge is installed. The height of the indicator changes with the level of cleaning fluid remaining.

#### Note:

You can also check the level of ink remaining using the *Ink Level* option in the menus.

 ["The Ink Level Menu" on page 129](#)

### 2 Ink color codes

SC-S70600 Series

MS : Metallic Silver

LK : Light Black

BK : Black

C : Cyan

M : Magenta

Y : Yellow

OR : Orange

LC : Light Cyan

LM : Light Magenta

WH : White

SC-S50600 Series

WH : White

BK : Black

Y : Yellow

M : Magenta

C : Cyan

SC-S30600 Series

BK : Black

Y : Yellow

M : Magenta

## Introduction

C : Cyan

### 5 Waste ink bottle status

Displays the approximate amount of space available in the waste ink bottle. The display changes as shown below when the waste ink bottle is nearly full or an error occurs.



#### 1 Status indicators

The status of the waste ink bottle is shown as follows.

 : No error. The indicator changes to show the amount of space available.

 : The waste ink bottle is almost full. Ready a new waste ink bottle.

 : The waste ink bottle is full. Replace with a new waste ink bottle.

### 6 Media lift detection status

This is displayed by the SC-S50600 series only.

 : The printer checks whether the media lifts during printing.

 : The printer does not check whether the media lifts during printing.

 [“The Maintenance Menu” on page 127](#)

### 7 Additional print drying system status

This display shows settings for the additional print drying system (supplied with the SC-S50600 series; optional with other models).

No icon : Not installed, or it is not installed correctly.

 : The drying fan is enabled.



: The drying fan is not enabled. To start the fan, select **Additional Dryer for On** in the setup menu.

 [“The Media Setup Menu” on page 120](#)

## Introduction

# Features

This wide-format color ink jet printer supports roll media 1626 mm (64 inches) in width. The main features of this printer are described below.

---

## Realizing High Productivity

### Triple Heaters

The three heaters listed below support improved productivity and print quality.

The pre-heater: Warms media before printing to protect the print area from sudden changes in temperature.

The platen heater: Ensures that the ink adheres evenly.

The after heater: Can be used to rapidly dry ink after printing.

### Media Feeding Unit Accommodates High-Capacity Rolls

The standard media feeding unit can handle high-capacity rolls with external diameters of up to 250mm and weights of up to 40 kg, ensuring that media requires less frequent replacement.

With the optional heavy roll media system, the printer can handle even larger 80 kg rolls with external diameters of 300 mm.

### Auto Take-up Reel Unit Comes Standard

The auto take-up reel unit automatically takes up printed media cleanly, with no wrinkles. You'll find it comes in handy for banner printing, high-volume print jobs, and continuous overnight printing.

### High-Capacity Ink Cartridges

The printer uses high-capacity, 700 ml ink cartridges (white ink cartridges 600 ml, metallic silver cartridges 350 ml) to ensure productivity, reducing the nuisance of frequent ink replacements.

### High-Speed Printing

The SC-S50600 series is equipped with two heads for faster printing. High speeds are supported by using two cartridges for each color of ink.

### Additional Print Drying System Available

The additional print drying system (supplied with the SC-S50600 series; optional with other models) can be used for increased drying performance and improved productivity. It is recommended when using the SC-S70600 series in 10 color mode, as the white and metallic silver inks are slow to dry.

---

## High Print Quality

### Smooth Tone Gradations, High-Fidelity Color Reproduction

The SC-S70600 series is equipped for light-colored inks (light black, light cyan and light magenta), reducing grain for continuous tone gradation, while the use of orange ink increases the color gamut for high-fidelity color reproduction. It is capable of print quality of a level sufficient for car wraps and indoor display advertising that can be inspected at close range.

### Support for White and Metallic Silver Inks

A variety of print effects are available when using the SC-S70600 series with white and metallic silver inks or the SC-S50600 series with white ink. The white ink is high opacity, making it suitable for masking on transparent media (window graphics). Other inks can be printed over white or metallic silver inks (ink layering), preventing color inks showing through and allowing for a variety of metallic colors.

#### **Note:**

*Note the following when using ink layering.*

- Use media at least 2% longer than specified in document size settings.*
- Note that the auto take-up reel unit may not function as expected, causing a decline in print quality.*
- Some media types, such as banner and canvas, are not supported. Before buying media in large quantities, try printing on a smaller sample and check the results.*

---

## Superior Ease of Use

### Media Installation and Take up a Snap

The roll and roll core holders require no spindles, eliminating the need to attach spindles before installing media. Just bring the media to the printer and install it directly. Never having to juggle long spindles makes installing media a snap even where space is limited.

## Introduction

In addition to roll supports that give you a place to rest media during installation, the printer offers lift levers that allow heavy media to be effortlessly raised to the level of the roll holders.

### Nearly Odorless Solvent Ink

The distinctive odor of solvent-based inks has been reduced with our solvent inks. This not only improves the work environment during printing but ensures that items intended for indoor display can be exhibited in any venue.

### Media Lift Detection

The SC-S50600 series is equipped with a system for detecting media lift during printing. If the media lifts during printing, printing will stop to prevent the media coming into contact with the print head. Stopping printing avoids printing errors and prevents waste of ink and media.

### Ease of Maintenance

Print quality can only be ensured through daily maintenance. The design of this printer leaves plenty of space for maintenance, making maintenance a snap.

### E-Mail Error/Warning Notification

The EpsonNet Config with Web Browser system built into the printer's network interface offers e-mail notification. Once configured for e-mail notification, the printer will send errors and warnings to selected e-mail addresses, ensuring peace of mind when the printer is left unmanned during overnight operation and in other similar situations.

Starting EpsonNet Config (with Web Browser)  *Network Guide (pdf)*

### Lamp and Buzzer Error Alerts

When an error occurs, a buzzer will sound and the alert lamp will light. The large alert lamp is highly visible, even at a distance.

A buzzer sounds simultaneously to prevent time wasted while stoppages due to errors go unnoticed.

### High-Speed USB/Gigabit Ethernet

The printer comes equipped with high-speed USB and 100 Base-TX/1000 Base-T network interfaces.

## Notes on Usage and Storage

In this document, white ink and metallic silver ink are listed as "spot color ink".

### Installation space

Make sure that you secure the following space, clear of any other objects, so that paper ejection and consumable replacement are not obstructed.

See the "Specifications Table" for the external dimensions of the printer.

 ["Specifications Table" on page 153](#)

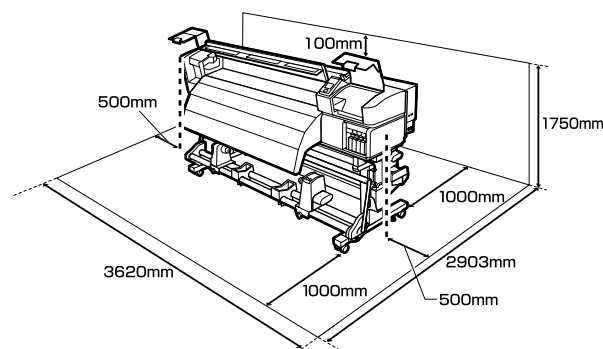

### Notes when using the printer

Note the following points when using this printer to avoid breakdowns, malfunctions, and print quality decline.

When using spot color ink, observe the following points as well.

 ["Notes on Usage of Spot color Inks \(SC-S70600 series, SC-S50600 series\)" on page 27](#)

- When using the printer, observe the operating temperature and humidity range described in the "Specifications Table".  ["Specifications Table" on page 153](#)

Note, however, that the desired results may not be achieved if the temperature and humidity are within the limits for the printer but not within those for the media. Be sure the operating conditions suit



## Introduction

the media. For more information, see the documentation supplied with the media.

Also, when operating in dry areas, air conditioned environment, or under direct sunlight, maintain the appropriate humidity.

- ❑ Avoid using the printer in locations with heat sources or that are exposed to direct draughts from ventilators or air conditioners. The print head nozzles could dry out and clog.
- ❑ Do not bend or tug the waste ink tube. Ink could spill inside or around the printer.
- ❑ Maintenance such as cleaning and replacement must be performed according to usage frequency or at recommended intervals. Failure to perform regular maintenance could result in loss of print quality. In the absence of the appropriate maintenance, continued use could damage the print head.

 [“Maintenance types and frequency” on page 85](#)

- ❑ The print head may not be capped (the print head may not return to the right side) if the printer is turned off when the media is jammed or an error has occurred. Capping is a function for automatically covering the print head with a cap (lid) to prevent the print head from drying out. In this case, turn on the power and wait a while until capping is performed automatically.
- ❑ When the power is on, do not remove the power plug or cut the power at the breaker. The print head may not be capped properly. In this case, turn on the power and wait a while until capping is performed automatically.
- ❑ The print head is automatically cleaned at a fixed interval after printing to keep the nozzle from clogging.

Be sure that the waste ink bottle is placed whenever the printer is on.

Periodical Cleaning  [“Printer Setup Menu” on page 124](#)

- ❑ As well as being expended during printing, ink is used during head cleaning and other maintenance required to keep the print head in working order.

## Notes when not using the printer

If you are not using it, note the following points when storing the printer. If it is not stored correctly, you may not be able to print properly the next time it is used.

When using spot color ink, observe the following points as well.

 [“Notes on Usage of Spot color Inks \(SC-S70600 series, SC-S50600 series\)” on page 27](#)

- ❑ If the printer will not be used for an extended period (and switched off), use cleaning cartridges (available separately) and perform Pre-Storage Maint.. Leaving the heads unwashed causes permanent clogs.

See the following for more information.

 [“Long-term Storage \(Pre-storage Maintenance\)” on page 112](#)

- ❑ If you do not print for a long time and do not perform pre-storage maintenance, turn the printer on at least once every seven days.

If you do not print for a long time, the print head nozzles may become clogged. Head cleaning will be performed automatically after the printer is turned on and started. Head cleaning prevents clogged print heads and maintains print quality. Do not turn the printer off until cleaning is complete.

- ❑ If you have not used the printer for a long time, check the print head for clogging before you start printing. Perform head cleaning if the print head is clogged.

 [“Checking for clogged nozzles” on page 109](#)

- ❑ The pressure rollers may crease media left in the printer. The media may also become wavy or curled, causing jams or resulting in the media coming into contact with the print head. Remove the media before putting the printer in storage.

## Introduction

- ❑ Store the printer after confirming that the print head has been capped (the print head is positioned at the far right). If the print head is left uncapped for a long time, the print quality may decline.

**Note:**

*If the print head is not capped, turn the printer on, and then turn it off.*

- ❑ Close all covers before placing the printer in storage. If you are not using the printer for a long time, put an anti-static cloth or cover on the printer to prevent dust. The print head nozzles are very small, and they can become clogged easily if fine dust gets on the print head, and you may not be able to print properly.
- ❑ When storing the printer, be sure that it is level: do not store it on an angle, on end, or upside down.

## Notes on handling ink cartridges

Note the following points when handling ink cartridges to maintain good print quality.

When using spot color ink, observe the following points as well.

 [“Notes on Usage of Spot color Inks \(SC-S70600 series, SC-S50600 series\)” on page 27](#)

- ❑ Extra ink is required to fully charge the print head nozzles the first time the printer is used; replacement cartridges will be needed earlier than usual. Store ink cartridges at room temperature in a location that is not exposed to direct sunlight.
- ❑ Store ink cleaner at room temperature out of direct sunlight.
- ❑ To ensure print quality, use all the ink in the cartridge before the earlier of the following dates:
  - ❑ The expiry date shown on the ink cartridge packaging
  - ❑ Six months after opening the package of ink cartridge
- ❑ If you move ink cartridges from a cold place to a warm place, leave it at room temperature for more than four hours before using the ink cartridge.

- ❑ Do not touch the ink cartridge IC chip. You may not be able to print properly.
- ❑ Fill all slots using ink or replacement cartridges (replacement cartridges are required in 8 and 4 color modes). You cannot print if any of the slots are empty.
- ❑ Do not leave the printer without ink cartridges installed. The ink in the printer will dry out and the printer will not function as expected. Leave ink cartridges or replacement cartridges in all slots even when the printer is not in use.
- ❑ Because the green IC chip contains the cartridge's own information such as the remaining ink level, you can still reinstall and use the ink cartridge after removing it from the printer.
- ❑ Use a cleaning stick from the supplied maintenance kit to wipe ink from the ink supply port of cartridges that have been removed from the printer before all the ink is used. Dried ink on the supply port may cause ink leaks when the cartridge is reinserted and used.

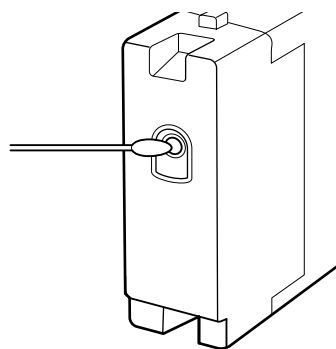

While cartridges are in storage, keep the ink supply ports free of dust. The ink supply port has a valve in it so it does not need to be capped.

- ❑ Removed ink cartridges may have ink around the ink supply port, so be careful not to get any ink on the surrounding area when removing the cartridges.
- ❑ To maintain the quality of the print head, this printer stops printing before ink cartridges are completely expended.
- ❑ Although the ink cartridges may contain recycled materials, this does not effect printer function or performance.

## Introduction

- ❑ Do not dismantle or remodel ink cartridges. You may not be able to print properly.
- ❑ Do not drop or knock it against hard objects; otherwise, the ink may leak.
- ❑ With the exception of spot color inks, ink cartridges must be removed and thoroughly shaken once every three weeks.

Shaking ink cartridges ↗ “[Replacement and Shake Methods](#)” on page 101

- ❑ Do not insert or remove replacement cartridges during printing.

---

## Handling Media

Note the following when handling or storing media. Media that are in poor condition will not produce good quality prints.

Be sure to read the documentation provided with each type of media.

### Notes on Handling

- ❑ Do not fold the media or damage the printable surface.
- ❑ Do not touch the printable surface. Moisture and oils from your hands can affect print quality.
- ❑ When handling media, hold it by both edges. We recommend wearing cotton gloves.
- ❑ Keep the media dry.
- ❑ Packaging materials can be used to store media and should not be thrown away.
- ❑ Avoid locations that are subject to direct sunlight, excessive heat, or humidity.
- ❑ When not in use, media should be removed from the printer, rewound, and inserted in its original packaging for storage. Leaving media in the printer for extended periods may cause it to deteriorate.

### Handling Media After Printing

To maintain long lasting, high quality print results, note the following points.

- ❑ Do not rub or scratch the printed surface. If they are rubbed or scratched, the ink may peel off.
- ❑ Do not touch the printed surface, as this may remove the ink.
- ❑ Make sure printouts are completely dry before folding or stacking, as otherwise discoloration or other marks may appear where the prints touch. These marks will disappear if the prints are immediately separated and dried but will become permanent if the surfaces are not separated.
- ❑ Avoid direct sunlight.
- ❑ To prevent discoloration, display and store prints as instructed in the documentation supplied with the media.

## Notes on Usage of Spot color Inks (SC-S70600 series, SC-S50600 series)

Spot color inks are prone to sedimentation (components settling to the bottom of the liquid). Using the ink in this state can cause a decline in print quality and printer malfunction. Before using spot color inks, take note of the following cautions.

- ❑ We recommend keeping the power on when using installed spot color ink cartridges. If the printer power is switched off, automatic circulation of spot color ink cannot be performed and printer may be damaged.
- ❑ Spot color ink cartridges must be stored flat (i.e., laid on their sides). If the cartridges are stored on end, shaking the cartridges before use may fail to dissolve the materials that have sedimented from the ink (i.e., settled to the bottom of the liquid) during storage.
- ❑ Spot color ink cartridges must be removed and thoroughly shaken once every 24 hours.

Shaking ink cartridges ↗ “[Replacement and Shake Methods](#)” on page 101

## Introduction

- ❑ If print results are uneven, perform Ink Circulation or Ink Refresh.

 [“Ink Circulation and Ink Refresh” on page 111](#)

## Introduction

# Using the Supplied Software

## Contents of the Software Disc



The following applications are available on the supplied software disk. Install as required.

For information about these applications, see the *Network Guide* (pdf) or the on-line help for the application in question.



**Note:**

- ❑ The supplied disk does not contain printer drivers. A software RIP is required for printing. Software not on the supplied software disk (including software RIPs and plug-ins for this printer) is available from the Epson website.
- ❑ The latest applications can be downloaded from the Epson website.

### For Windows

Software Name	Summary
EPSON LFP Remote Panel 2	<p>EPSON LFP Remote Panel 2 is used to update firmware from a computer and copy media settings bank created in the printer's setup menu to a computer.</p> <p> <a href="#">"Starting EPSON LFP Remote Panel 2" on page 30</a></p> <p> <a href="#">"Exiting EPSON LFP Remote Panel 2" on page 30</a></p>
Epson Driver and Utilities	<p>Epson communications drivers (the EPSON SC-S70600 Series Comm Driver, EPSON SC-S50600 Series Comm Driver, or EPSON SC-S30600 Series Comm Driver) are installed.</p> <p>The Epson communications driver is required if the EPSON LFP Remote Panel 2 is to be used to copy media settings. It is not a printer driver. In addition, the software RIP may not display printer status if the Epson communications driver is not installed when the printer is connected to a computer via USB. See the software RIP documentation for more information on the status display.</p>
Epson Network Utilities	Install and launch a wizard that will help you enter IP addresses for a simple network connection.
EpsonNet Config	With this software, you can configure various network settings for the printer from your computer. This is useful as it allows you to enter addresses and names using the keyboard.

### For Mac OS X

Software Name	Summary
EPSON LFP Remote Panel 2	<p>EPSON LFP Remote Panel 2 is used to update firmware from a computer and copy media settings bank created in the printer's setup menu to a computer.</p> <p> <a href="#">"Starting EPSON LFP Remote Panel 2" on page 30</a></p> <p> <a href="#">"Exiting EPSON LFP Remote Panel 2" on page 30</a></p>
Epson Network Utilities	Install and launch a wizard that will help you enter IP addresses for a simple network connection.
EpsonNet Config	With this software, you can configure various network settings for the printer from your computer. This is useful as it allows you to enter addresses and names using the keyboard.

## Introduction

### Starting EPSON LFP Remote Panel 2

Launch EPSON LFP Remote Panel 2 after confirming that the printer displays **Ready**.

#### Windows

**1** The application can be launched using either of the following two methods.

- Double-click the **EPSON LFP Remote Panel 2** icon on the desktop. The **EPSON LFP Remote Panel 2** icon is created when the application is installed.
- Click **Start > All Programs** (or **Programs**) > **EPSON LFP Remote Panel 2 > EPSON LFP Remote Panel 2**.

**2** Click the desired item in the EPSON LFP Remote Panel 2 main window.

See EPSON LFP Remote Panel 2 help for more information.

#### Mac OS X

Double-click **Applications > Epson Software > EPSON LFP Remote Panel 2 > EPSON LFP Remote Panel 2** to open the EPSON LFP Remote Panel 2 main window.

### Exiting EPSON LFP Remote Panel 2

Click **Finish** in the EPSON LFP Remote Panel 2 main window.

### Uninstalling Software



#### Important:

- Log in to an "Computer administrator" account (an account with Administrators group privileges).
- Enter the administrator password when prompted and then proceed with the remainder of the operation.
- Exit any other applications that may be running.

#### Windows

This section describes how to uninstall EPSON LFP Remote Panel 2 and the Epson communications driver.

**1** Turn off the printer, and unplug the interface cable.

**2** Go to the **Control Panel** and click **Uninstall a program** from the **Programs** category.

In Windows XP, go to the **Control Panel** and click **Add or Remove Programs**.

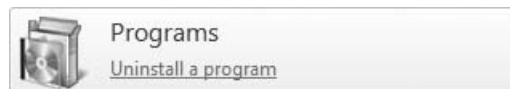

**3** Select the software you want to remove and then click **Uninstall/Change** (or **Change/Remove**).

Selecting the following deletes the Epson communications drivers.

- EPSON SC-S70600 Series Comm Driver Printer Uninstall
- EPSON SC-S50600 Series Comm Driver Printer Uninstall
- EPSON SC-S30600 Series Comm Driver Printer Uninstall

To uninstall EPSON LFP Remote Panel 2, select EPSON LFP Remote Panel 2.

**4** Select the target printer icon, and then click **OK**.

## Introduction

**5** Follow the on-screen instructions to continue.

When the delete confirmation message appears, click **Yes**.

If you are reinstalling the Epson communications driver, restart the computer.

### Mac OS X

The following describes how to remove the EPSON LFP Remote Panel 2.

**1** Quit the EPSON LFP Remote Panel 2.

**2** Drag the entire **EPSON Remote Panel 2** folder from the **Applications** folder into the **Trash**.

Use the Uninstaller to uninstall other software. Uninstall the affected applications before performing a reinstall or update.

### Download

The Uninstaller can be downloaded from the Epson website.

URL: <http://www.epson.com>

### Uninstall

Follow the instructions provided at the Uninstaller download site.

## Basic Operations

# Basic Operations

## Loading and Exchanging Media

The process for loading media varies with the model of printer or type of media feeding unit used. Choose the method suited to your particular setup.

### ⚠ Caution:

- ❑ The heaters and media holding plate may be hot; observe all necessary precautions. Failure to observe the necessary precautions could result in burns.
- ❑ Be careful not to trap your hands or fingers when opening or closing the front cover. Failure to observe this precaution could result in injury.
- ❑ Do not rub your hands along the edges of the media. The edges of the media are sharp and can cause injury.

### ⚠ Important:

- ❑ Load media just before printing. The pressure rollers may crease media left in the printer. The media may also become wavy or curled, causing jams or resulting in the media coming into contact with the print head.
- ❑ If the following points are not observed when handling media, small amounts of dust and lint may stick to the media surface and cause ink drops in the print results.
- ❑ Do not place exposed media directly on the floor. Media should be rewound and inserted in its original packaging for storage.
- ❑ Do not carry media with the media surface pressed against clothing. Handle media in its individual packaging until just before loading the media in the printer.

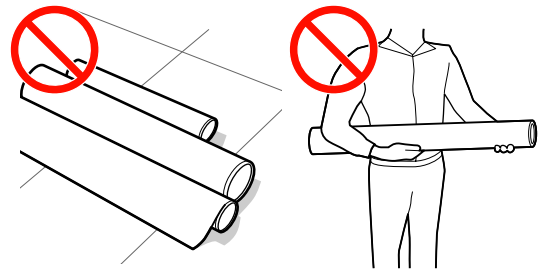

- ❑ If media is loaded and the right and left edges of the roll are uneven, media feeding problems may cause the media to move around during printing.

Either rewind to align the edges or use a roll without any issues.

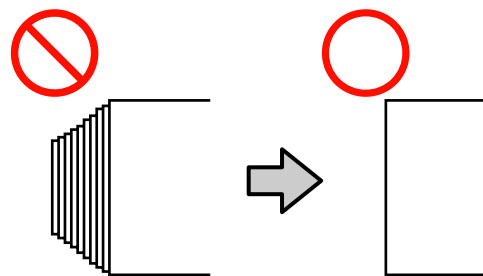

### Note:

For information on the media that can be used in the printer, see:

📖 [“Supported Media” on page 149](#)



## Basic Operations

### When using the SC-S70600 series or SC-S50600 series

The position to set the pressure rollers depends on the printing type or media width. Media is set in consideration of the positioning of the pressure rollers. Therefore, check the positioning of the pressure rollers in advance.

☞ “Positioning of the pressure rollers and media (SC-S70600 series, SC-S50600 series)” on page 33

### Using the SC-S30600 series

☞ “Loading Media (SC-S30600 series)” on page 48

## Positioning of the pressure rollers and media (SC-S70600 series, SC-S50600 series)

Pressure rollers must be set in the correct position to obtain good print results.

### Pressure roller types

There are two types of pressure rollers. As shown below, the pressure roller to use depends on the type of printing.

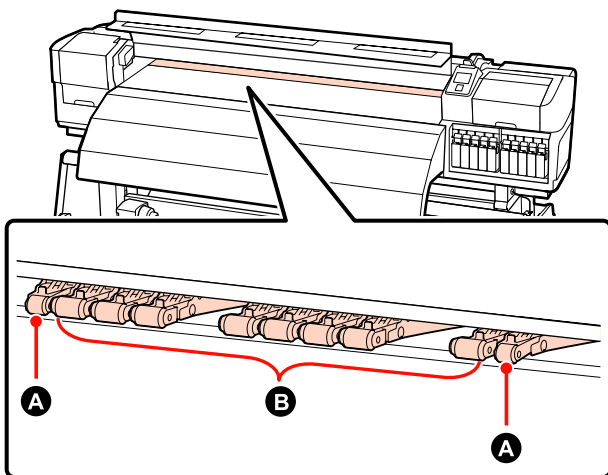

- Normal printing

Use low pressure rollers **B**. Note that the quantity of rollers to use depends on the media width.

- When transparent film is loaded or during ink layering

Use high pressure rollers **A**.

Ink layering ☞ “High Print Quality” on page 23

#### Note:

- If low pressure rollers are used when loading transparent film, the pressure rollers may leave the traces in the print area.
- If low pressure holders are used during ink layering, ink layering is not performed correctly.

## Basic Operations

### Positioning pressure rollers by media width

You can confirm the positioning of the pressure rollers by opening the front cover.

This section provides guidance for positioning by media width.

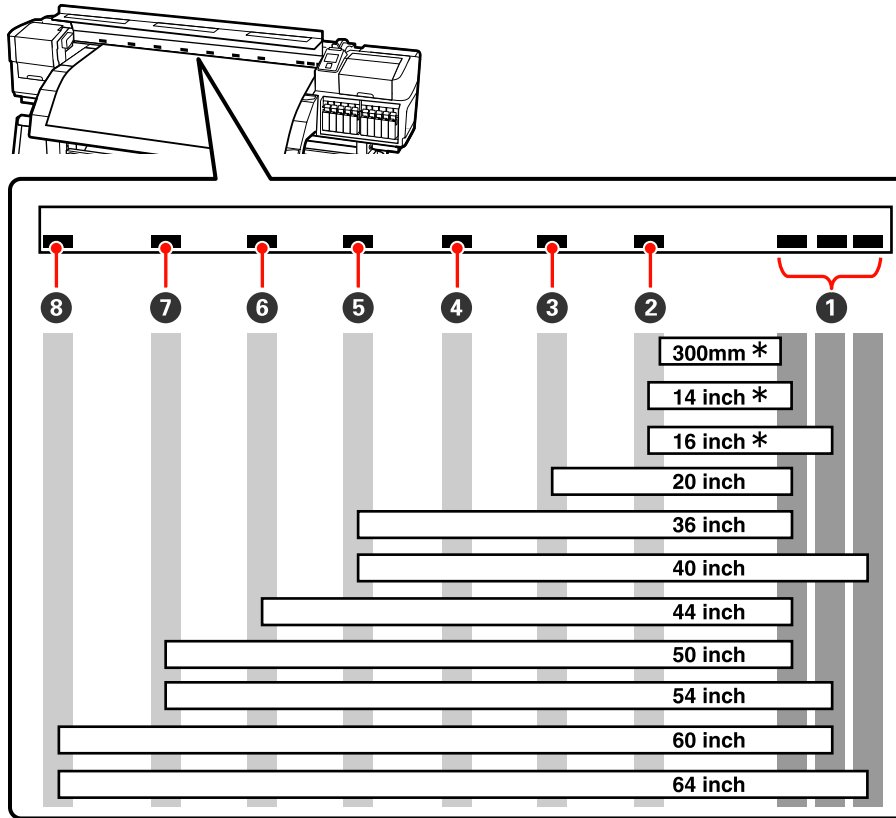

\* Transparent film and ink layering are not supported

If the pressure rollers are moved within the black labels and the media loading lever is lowered, the rollers secure the media. Rollers outside the black labels do not secure media even after the media loading lever is lowered.

### Positioning of media

There are square holes to indicate the pressure roller positions on the rear side printer as well.

Observe the following cautions when positioning media to ensure that the positioning of pressure rollers is appropriate for the media width.

- ❑ Ensure that the left edge of the media always passes within the range of ①.

### Basic Operations

- ❑ The right edge of the media must pass within the squares of ② through ⑧ according to the media width.

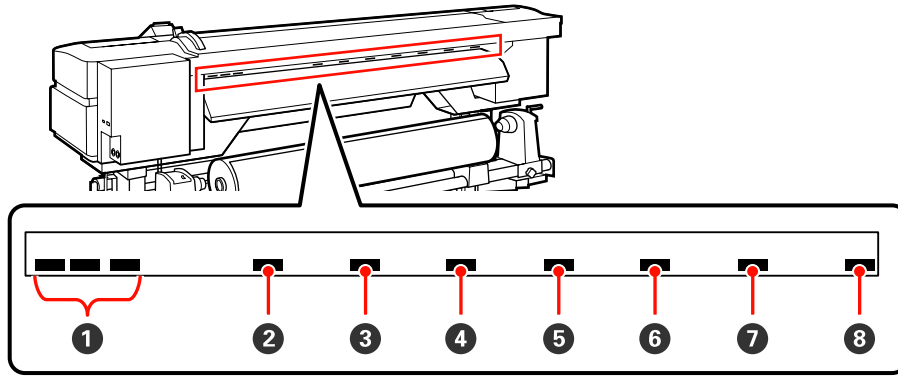

## Basic Operations

### Loading Media (SC-S70600 series, SC-S50600 series)

The procedure for loading media varies depending on whether you are using the supplied media feeding unit or the optional heavy roll media system.

Follow the steps below when using the supplied media feeding unit.

When the Heavy Roll Media Feeding Unit is installed, see: [🔗 “Using the Optional Heavy Roll Media Feeding Unit” on page 42](#)

### When the Standard Media Feeding Unit Is Installed

This section uses the SC-S70600 series to illustrate the process of loading media when the supplied media feeding unit is installed.



**Caution:**

Because the media is heavy, it should not be carried by one person. When loading or removing the media, use at least two persons.

1

Remove the media holding plates, if installed.

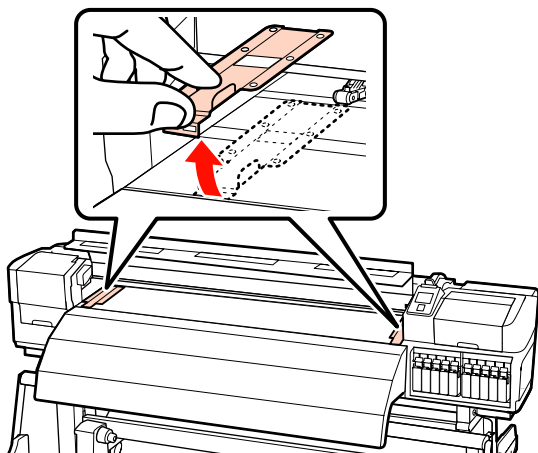

2

Turn on the printer by pressing the  button.



**Important:**

When spot color inks are installed, circulation will be performed automatically to prevent ink accumulating in the printer and causing clogs when the printer is not in use. Because turning the printer off prevents automatic circulation from being performed, leading to printer malfunction, we recommend that the printer not be turned off.

3

Loosen the roll holder fixing screws sufficiently and adjust the roll holders so that the distance between the two is wider than the media.

Center the roll supports between the roll holders.

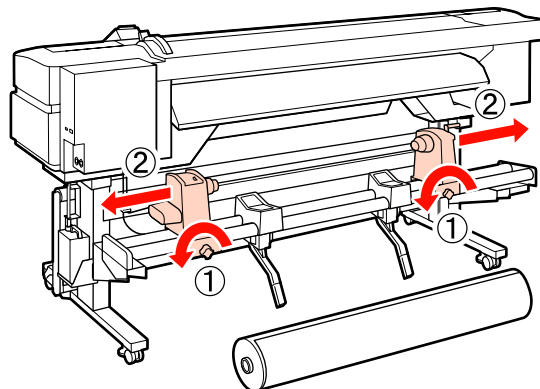

**Important:**

If the right holder handle shaft is not visible, rotate the holder forward until it stops. The media can not be properly loaded if the handle shaft is not visible.

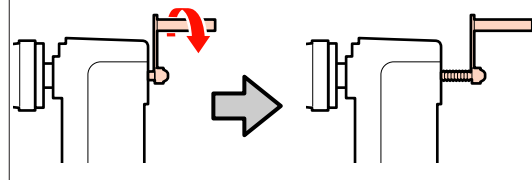

4

Temporarily place media on the roll supports oriented according to how it is rolled (see below)

**Printable Side Out**

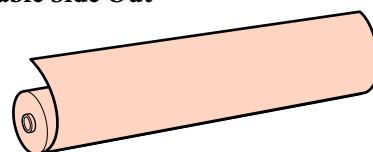

## Basic Operations

### Printable Side In

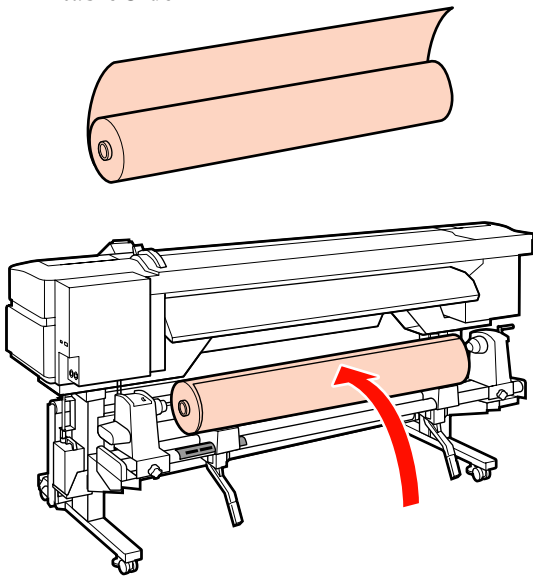

- 5** Align the left and right edges of the media with the set positions according to the media width.

Recommended positioning by media width

 ["Positioning pressure rollers by media width" on page 34](#)

Example of setting media with a width of 64 inches

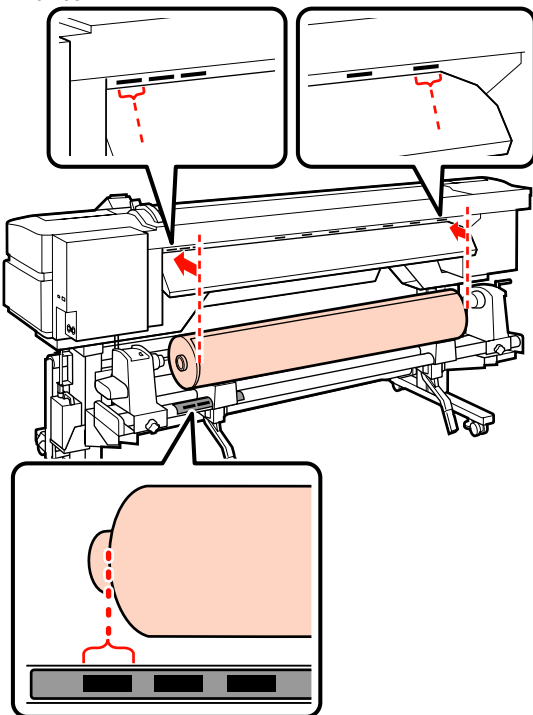

**Note:**

If the label with black squares is not in place, affix the label as described in the Setup Guide.

 [Setup Guide](#)

- 6** Raise the lift lever on the left side of the printer to lift the media into position, then firmly insert the roll holder.

If the roll of media has the outer diameter which is less than 140mm, lift it up by your hands, and set it to the roll holder. The roll core will not reach the holder when raised using the lift lever.

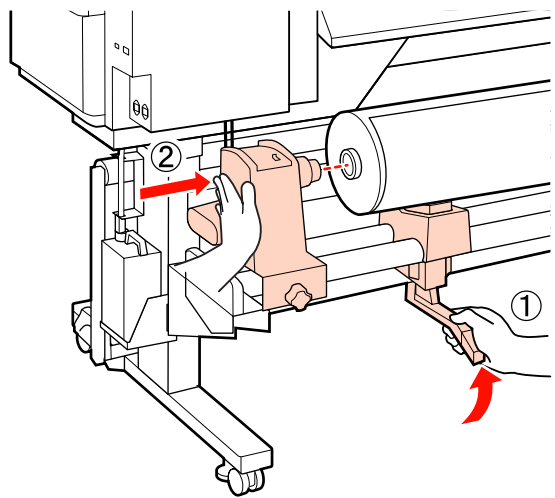

- 7** Tighten the roll holder screw until the screw no longer turns to fix the roll holder in place.

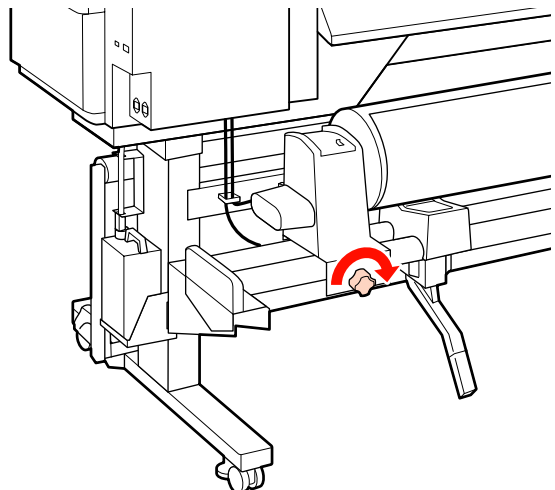

### Basic Operations

- 8** Raise the lift lever on the right side of the printer to lift the media into position, then firmly insert the roll holder.

If the roll of media has the outer diameter which is less than 140mm, lift it up by your hands, and set it to the roll holder as described in Step 6.

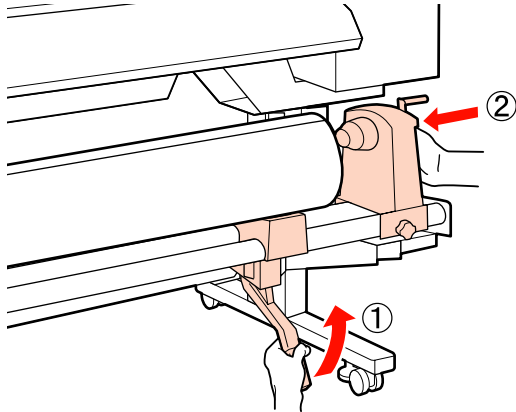

- 9** To ensure the roll holder is inserted into the roll core sufficiently, push the center section on the side of the roll holder towards the roll end twice.

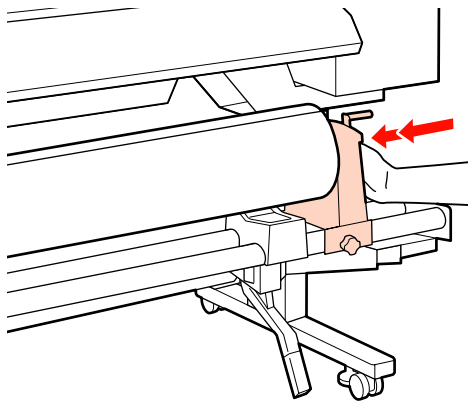

**! Important:**  
If the roll holder is inserted into the roll core insufficiently, media is not fed correctly during printing because of slippage between the roll holder and roll core.

This may cause banding in the print results.

- 10** Tighten the roll holder screw until the screw no longer turns to fix the roll holder in place.

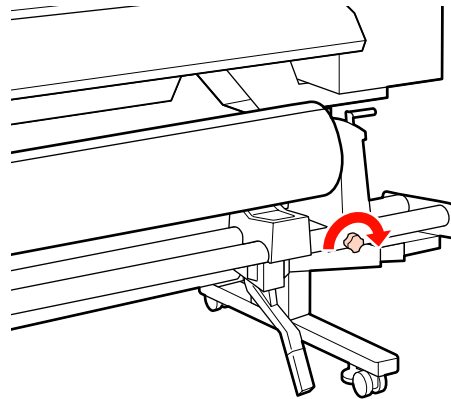

**! Important:**  
If the roll holder screw is loose, the roll holder may move during printing. This could cause stripes and unevenness in the print results.

- 11** Rotate the handle until part A in the illustration below is fully inserted.

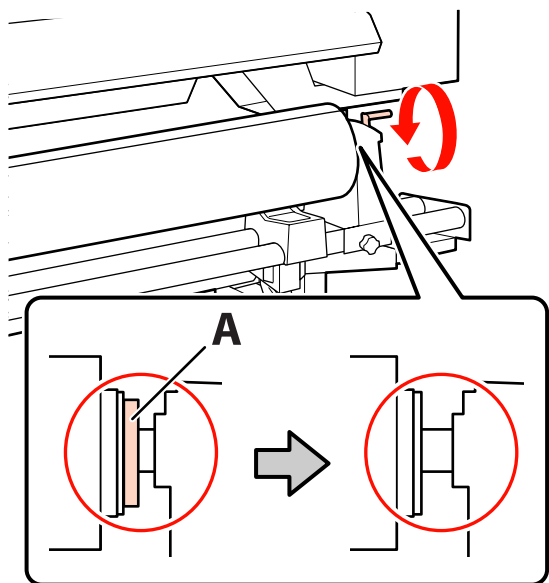

**! Important:**  
Once part A is hidden, do not turn the handle any further. Failure to observe this precaution could damage the roll holder.

If part A is still visible even after the handle has been turned fully, rewind the handle. Loosen the roll holder screw on the right side, and then restart from Step 9.

### Basic Operations

- 12** Confirm that the right and left edges of the attached roll are aligned.

If the right and left edges of the role are not aligned, realign them.

- 13** Raise the media loading lever.

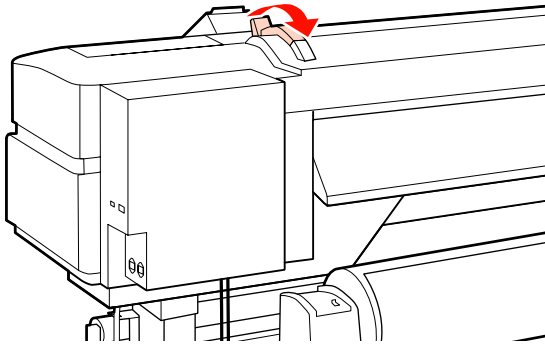

- 14** Pull out the media and insert it into the printer.

Insert the media so that it passes within the squares that indicate the set position, which were aligned in Step 5.

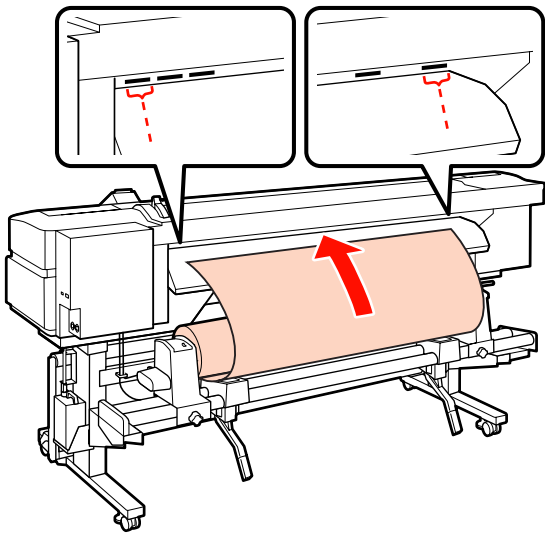

- 15** Insert the media past the pressure rollers and lower the media loading lever to hold it in place.

- 16** Go to the front of the printer and open the front cover.

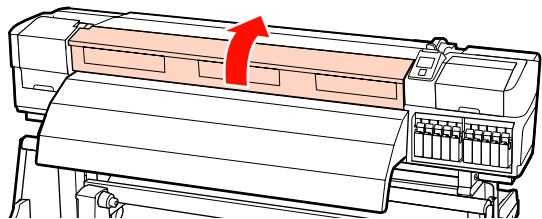

- 17** Hold the center of the media and raise the media loading lever.

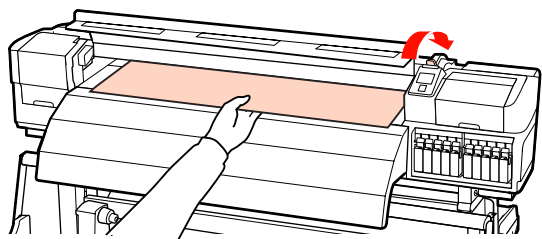

- 18** Pull the media straight forward until the edge has past the label on the top side of the after heater.

If the media is pulled passed the specified position, rewind the media to the specified position. The button to rewind media depends on how the loaded media is rolled.

Printable Side Out: Press the ▲ button.

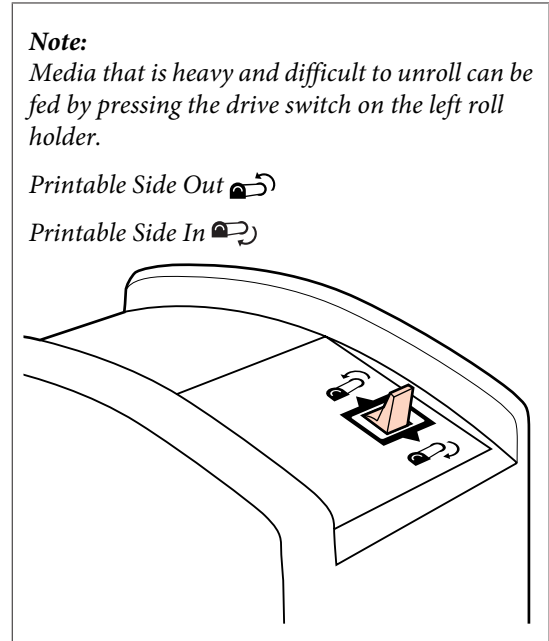

## Basic Operations

Printable Side In: Press the ▼ button.

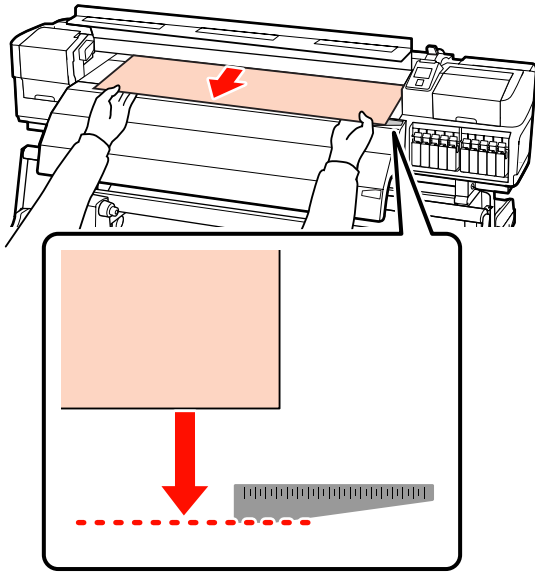

**Important:**

*If the media loading process is continued with the media pulled past the specified position, there will be looseness in the media, which will result in the print head striking the media during printing.*

**19**

Set the pressure rollers. The pressure roller positioning method differs for normal printing, when transparent film is loaded, and ink layering.

**Normal printing**

- ❑ Use low pressure rollers.
  - Move the high pressure rollers to right or left until they contact the ends.
- ❑ We recommend setting the low pressure rollers to be set at the edges of the media within 5 mm of the edges.
- ❑ Position the remaining low pressure rollers within the black square labels. There may be extraneous low pressure rollers depending on the media width. Position the extraneous low pressure rollers away from the black square labels.

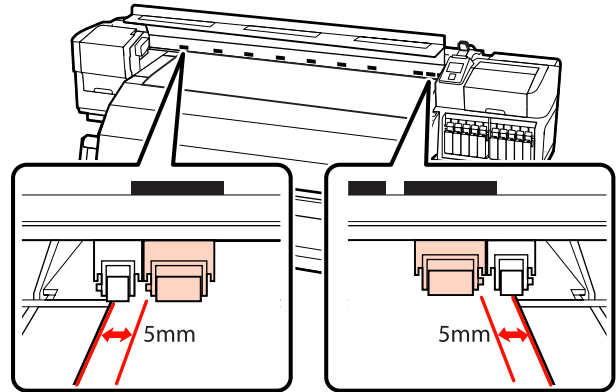

**When transparent film is loaded or during ink layering**

Ink layering ↗ “High Print Quality” on page 23

- ❑ Use high pressure rollers only.
- ❑ We recommend positioning the rollers within 10 mm from the left and right edges of the media.
- ❑ Position the low pressure rollers away from the black square labels.

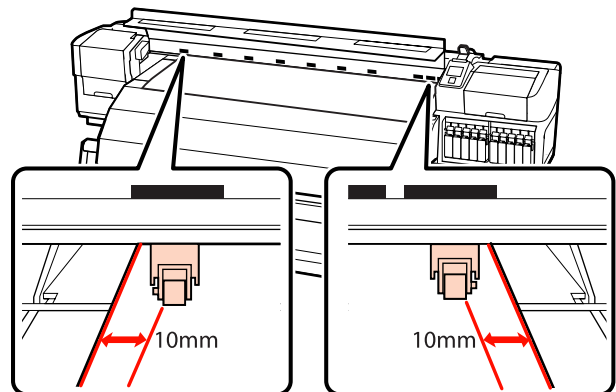

**20**

If the media loading lever is lowered, the pressure rollers set at the black square labels secure the media.

To print immediately, proceed to Step 21.

For information on loading the media into the auto take-up reel unit, see:



## Basic Operations

 "Using the Auto Take-up Reel Unit" on page 62

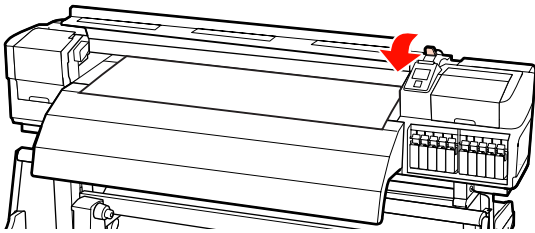

### 21 Attach the media holding plates.

First, position the plates so that the edges of the media are at the centers of the round holes.

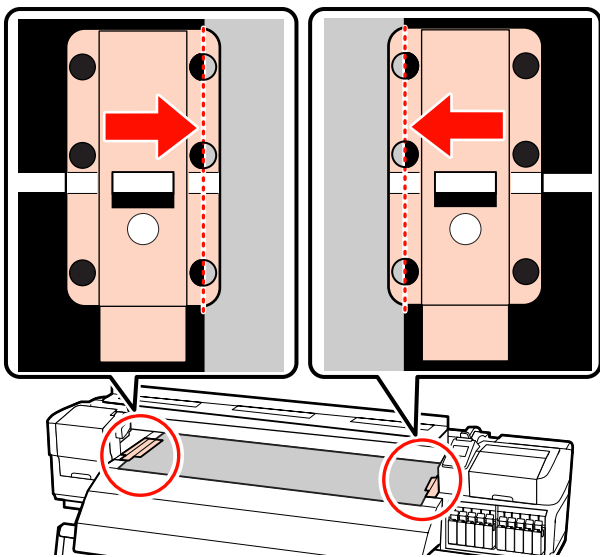

**!** **Important:**  
Always position the plates so that the edges of the media are at the centers of the round holes. Incorrect positioning causes banding (horizontal banding, lines, or strips of uneven color) during printing.

### 22 Align the white lines of the plates with the white lines of the platen and push the plates down to lock them in place and keep them from lifting.

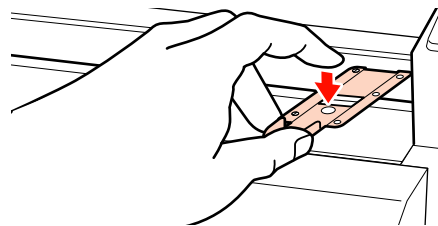
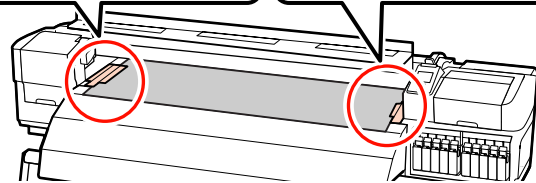
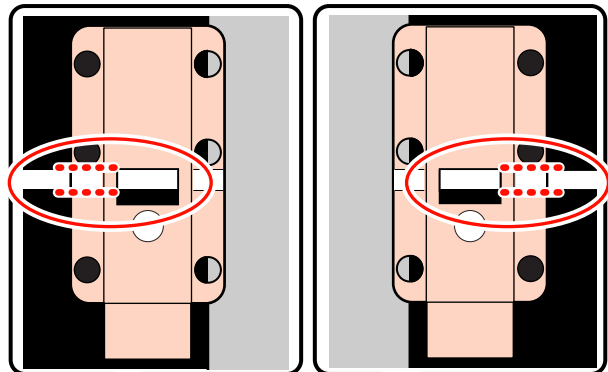

**!** **Important:**

- Do not use the media holding plates with media that is 0.4 mm or more thick. The media holding plates could touch and damage the print head.
- Move the media holding plates to the left and right edges of the platen when they are not in use.
- Do not use the media holding plates if the sides of the printed media are smudged or torn.

### 23 Close the front cover.

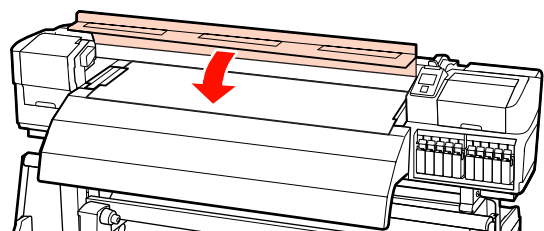

## Basic Operations

### Using the Optional Heavy Roll Media Feeding Unit

This section uses the SC-S70600 series to illustrate how to load media when the optional heavy roll media feeding unit is installed.

Using a lifter is recommended when handling a media that is 40 kg or heavier.

The explanation that follows assumes that a lifter is used.

The following types of lifter can be used.

- ❑ Fork or platform thickness: 28 mm or less
- ❑ Fork or platform can be lowered to approx. 190mm from the floor.

#### **Caution:**

Because the media is heavy, it should not be carried by one person. When loading or removing the media, use at least two persons. Using a lifter is recommended when handling a media that is 40 kg or heavier.

- 1 Remove the media holding plates, if installed.

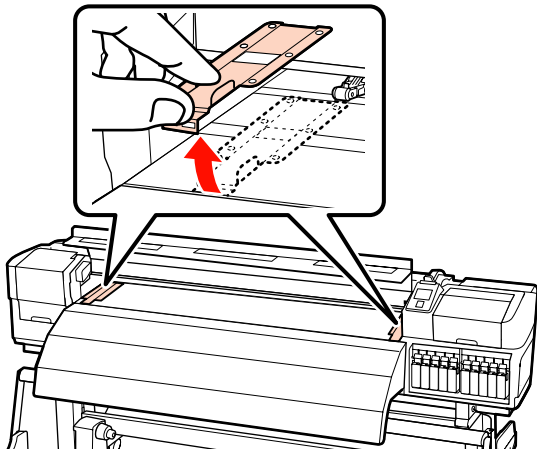

- 2 Turn on the printer by pressing the  button.

#### **Important:**

When spot color inks are installed, circulation will be performed automatically to prevent ink accumulating in the printer and causing clogs when the printer is not in use. Because turning the printer off prevents automatic circulation from being performed, leading to printer malfunction, we recommend that the printer not be turned off.

- 3 Loosen the left and right roll holder fixing screws sufficiently and separate the roll holders so that the distance between them is wider than the media.

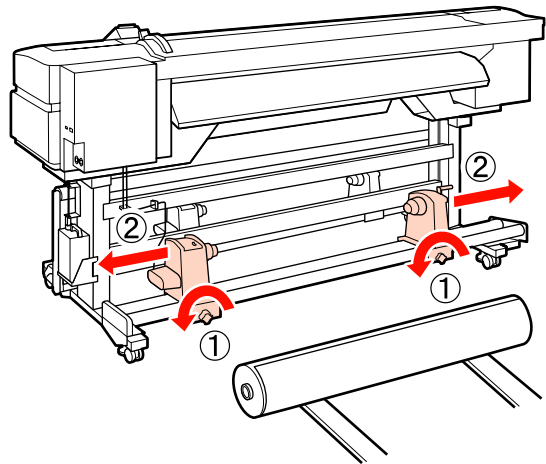

#### **Important:**

If the right holder handle shaft is not visible, rotate the holder forward until it stops. The media can not be properly loaded if the handle shaft is not visible.

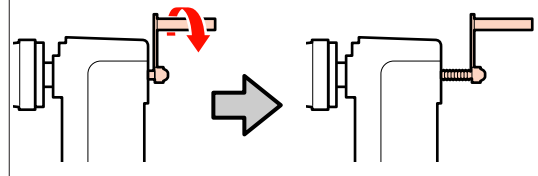

## Basic Operations

- 4** Temporarily place media on the lifter oriented according to how it is rolled (see below)

### Printable Side Out

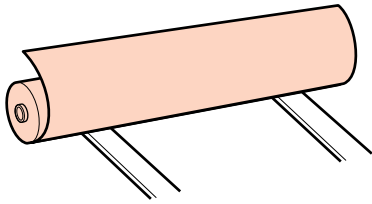

### Printable Side In

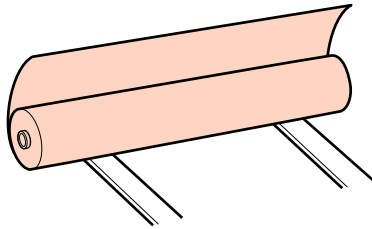

- 5** Align the left and right edges of the media with the set positions according to the media width.

Recommended positioning by media width

 [“Positioning pressure rollers by media width” on page 34](#)

Example of setting media with a width of 64 inches

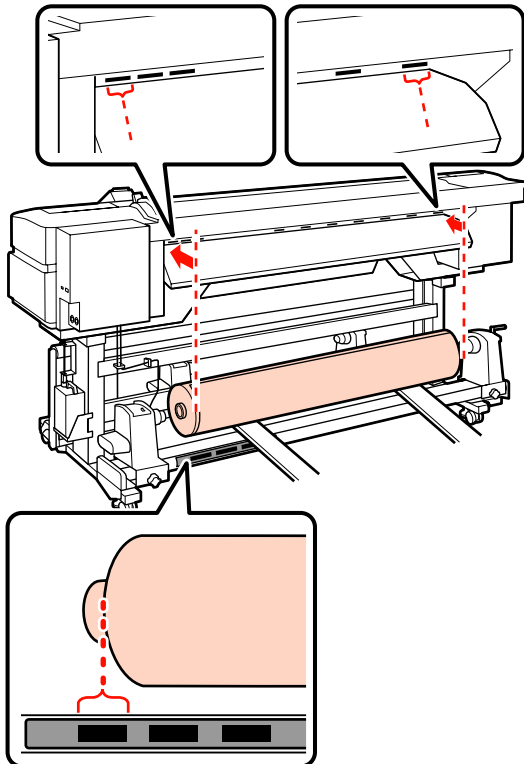

### Note:

*If the label with black squares is not in place, affix the label as described in the Setup Guide.*

 [Setup Guide](#)

- 6** Align the media and the roll holders.

Raise or lower the lifter until the media roll core is level with the roll holders.

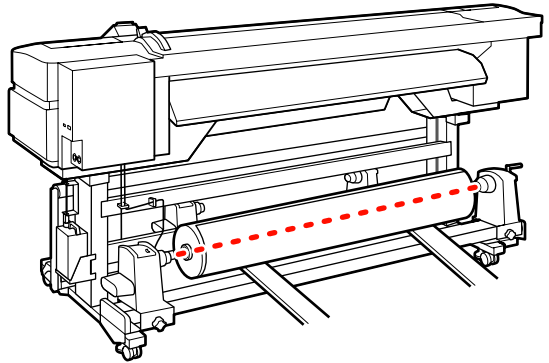

- 7** Fully insert the left roll holder. Next, tighten the roll holder screw until the screw no longer turns to fix the roll holder in place.

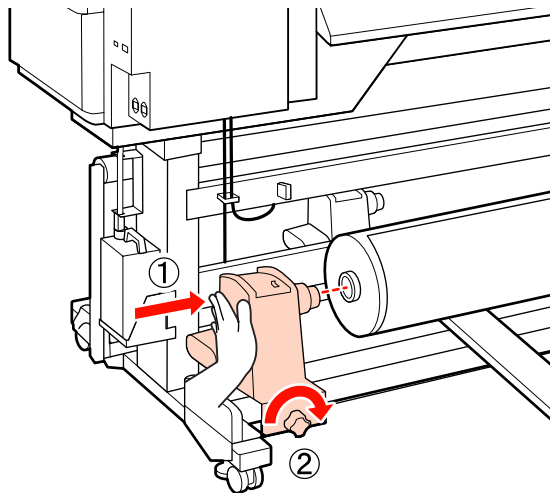

**Basic Operations**

- 8** Fully insert the right roll holder.

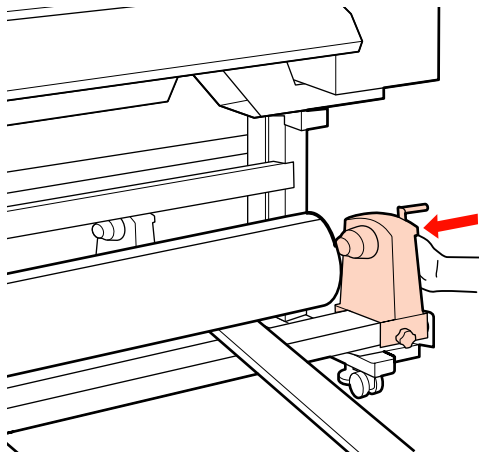

- 9** To ensure the roll holder is inserted into the roll core sufficiently, push the center section on the side of the roll holder towards the roll end twice.

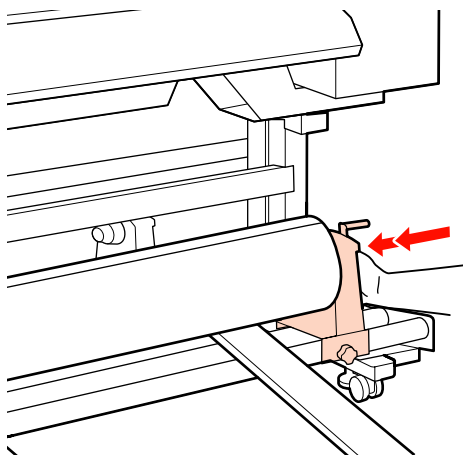

**!** **Important:**  
 If the roll holder is inserted into the roll core insufficiently, media is not fed correctly during printing because of slippage between the roll holder and roll core.  
 This may cause banding in the print results.

- 10** Tighten the roll holder screw until the screw no longer turns to fix the roll holder in place.

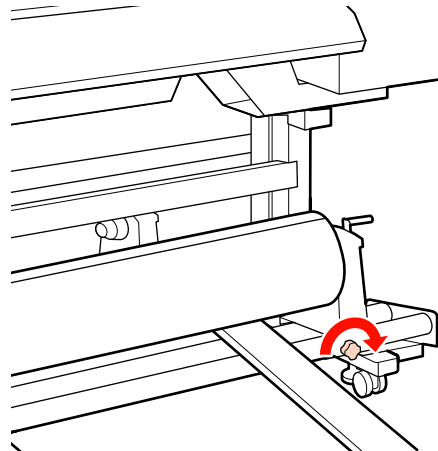

**!** **Important:**  
 If the roll holder screw is loose, the roll holder may move during printing. This could cause stripes and unevenness in the print results.

- 11** Remove the lifter.

- 12** Rotate the handle until part A in the illustration below is fully inserted.

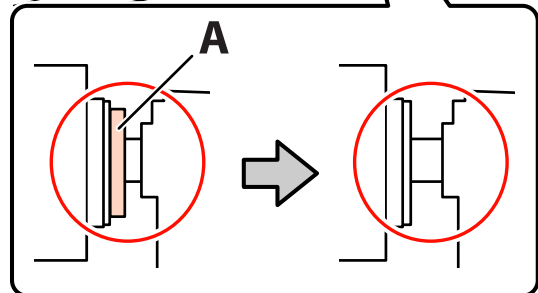
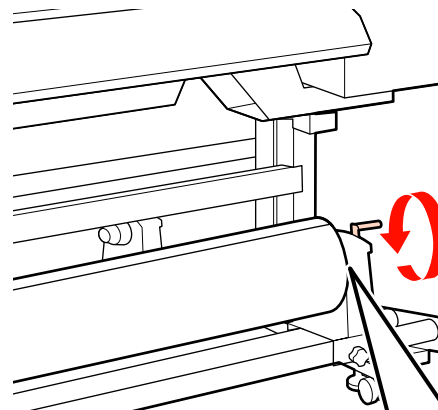

## Basic Operations



**Important:**

Once part A is hidden, do not turn the handle any further. Failure to observe this precaution could damage the roll holder.

If part A is still visible even after the handle has been turned fully, rewind the handle. Loosen the roll holder screw on the right side, and then restart from Step 8.

**13**

Confirm that the right and left edges of the attached roll are aligned.

If the right and left edges of the role are not aligned, realign them.

**14**

Raise the media loading lever.

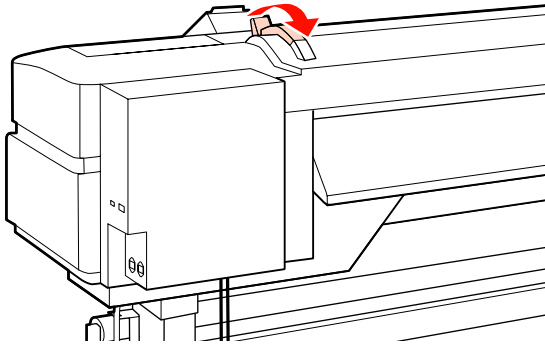

**15**

Pull out the media and insert it into the printer.

Insert the media so that it passes within the squares that indicate the set position, which were aligned in Step 5.

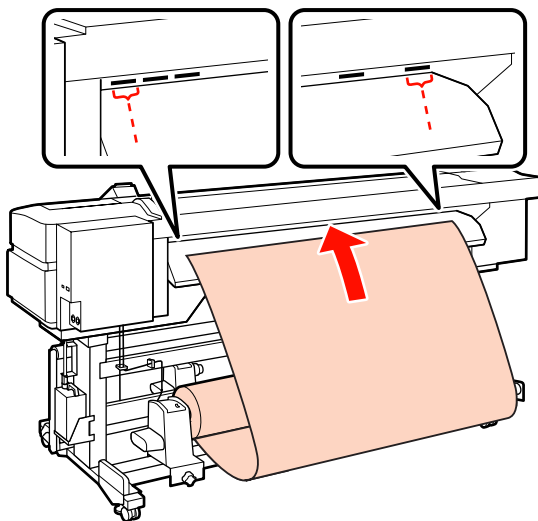

**Note:**

Media that is heavy and difficult to unroll can be fed by pressing the drive switch on the left roll holder.

Printable Side Out

Printable Side In

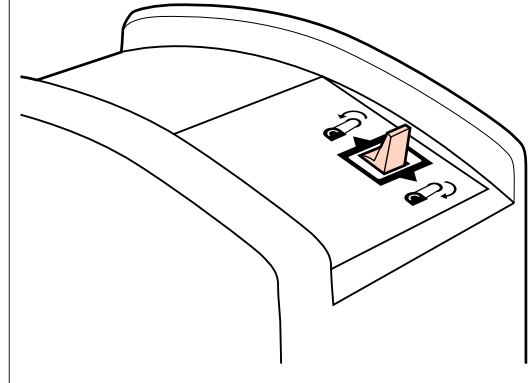

**16**

Insert the media past the pressure rollers and lower the media loading lever to hold it in place.

**17**

Go to the front of the printer and open the front cover.

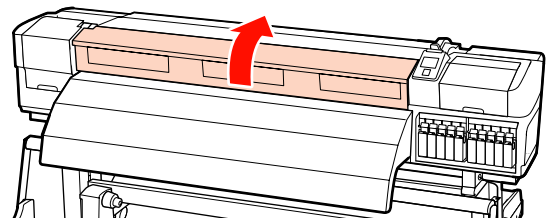

**18**

Hold the center of the media and raise the media loading lever.

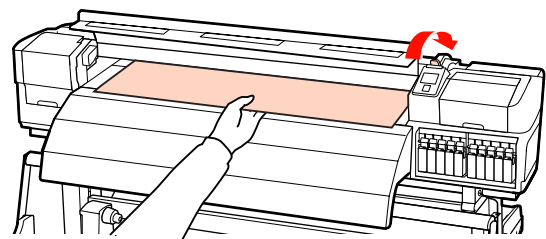

**19**

Pull the media straight forward until the edge has past the label on the top side of the after heater.

If the media is pulled passed the specified position, rewind the media to the specified position. The button to rewind media depends on how the loaded media is rolled.

Printable Side Out: Press the ▲ button.

## Basic Operations

Printable Side In: Press the ▼ button.

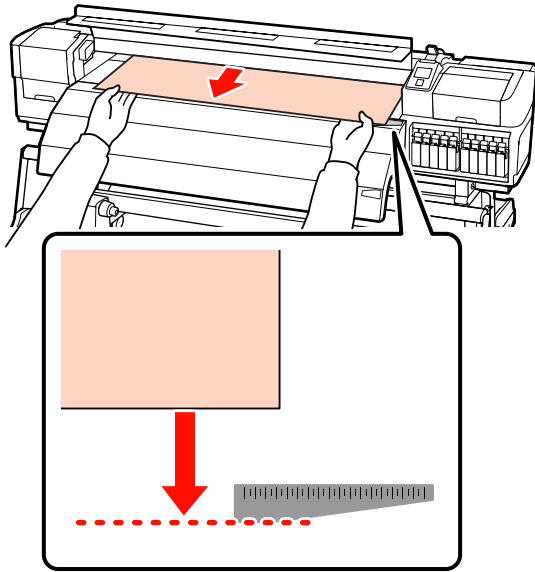

### Important:

*If the media loading process is continued with the media pulled past the specified position, there will be looseness in the media, which will result in the print head striking the media during printing.*

20

Set the pressure rollers. The pressure roller positioning method differs for normal printing, when transparent film is loaded, and ink layering.

### Normal printing

- ❑ Use low pressure rollers.
  - Move the high pressure rollers to right or left until they contact the ends.
- ❑ We recommend setting the low pressure rollers to be set at the edges of the media within 5 mm of the edges.
- ❑ Position the remaining low pressure rollers within the black square labels. There may be extraneous low pressure rollers depending on the media width. Position the extraneous low pressure rollers away from the black square labels.

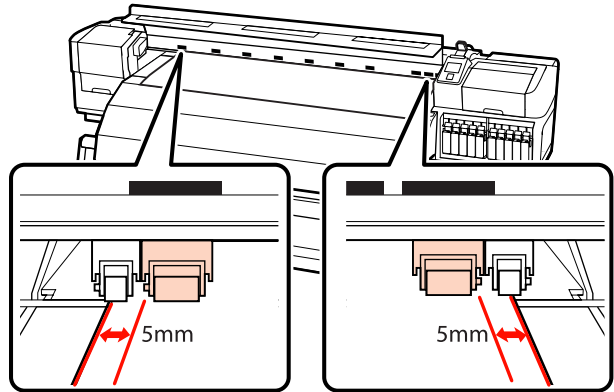

### When transparent film is loaded or during ink layering

Ink layering  "High Print Quality" on page 23

- ❑ Use high pressure rollers only.
- ❑ We recommend positioning the rollers within 10 mm from the left and right edges of the media.
- ❑ Position the low pressure rollers away from the black square labels.

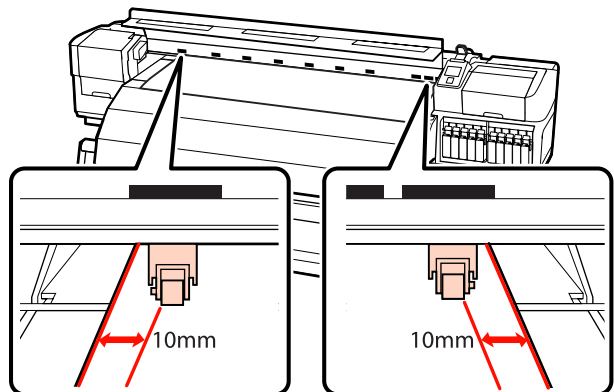

21

If the media loading lever is lowered, the pressure rollers set at the black square labels secure the media.

To print immediately, proceed to Step 22.

For information on loading the media into the auto take-up reel unit, see:

### Basic Operations

 "Using the Auto Take-up Reel Unit" on page 62

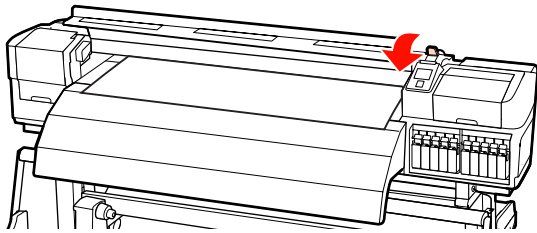

#### 22 Attach the media holding plates.

First, position the plates so that the edges of the media are at the centers of the round holes.

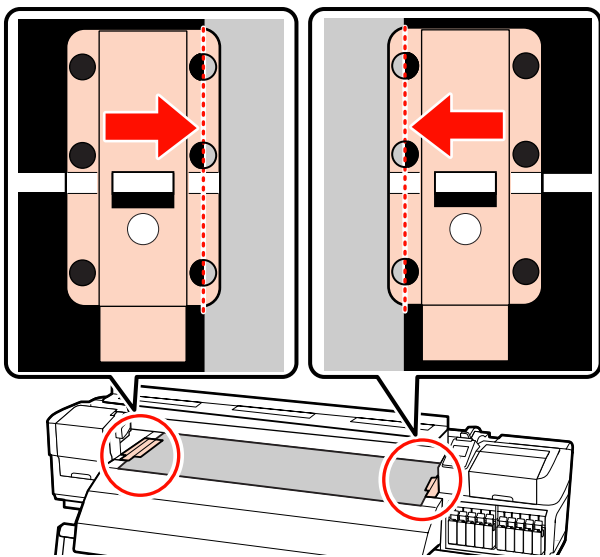

**!** **Important:**  
Always position the plates so that the edges of the media are at the centers of the round holes. Incorrect positioning causes banding (horizontal banding, lines, or strips of uneven color) during printing.

#### 23 Align the white lines of the plates with the white lines of the platen and push the plates down to lock them in place and keep them from lifting.

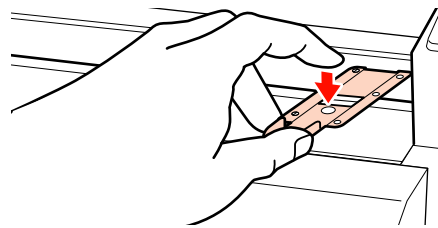
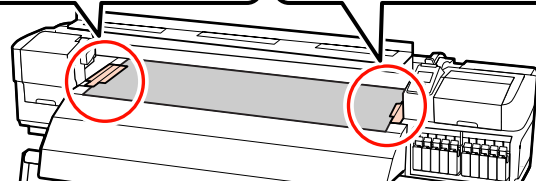
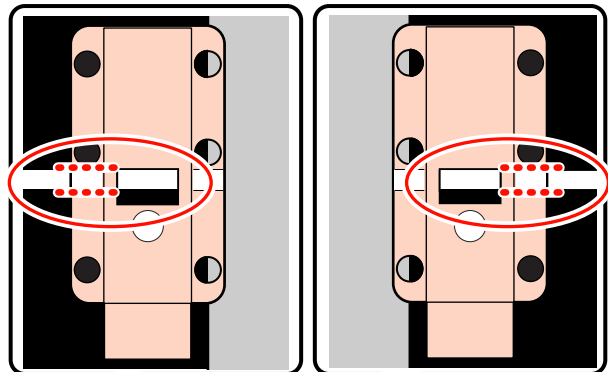

**!** **Important:**

- Do not use the media holding plates with media that is 0.4 mm or more thick. The media holding plates could touch and damage the print head.
- Move the media holding plates to the left and right edges of the platen when they are not in use.
- Do not use the media holding plates if the sides of the printed media are smudged or torn.

#### 24 Close the front cover.

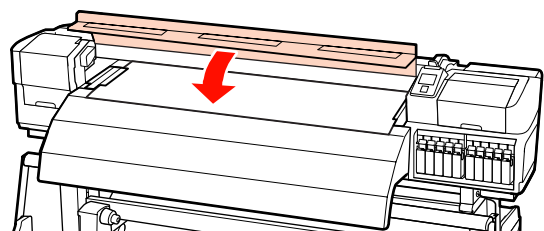

## Basic Operations

### Loading Media (SC-S30600 series)

The procedure for loading media varies depending on whether you are using the installed media feeding unit or the optional heavy roll media system.

Follow the steps below when using the supplied media feeding unit.

When the Heavy Roll Media Feeding Unit is installed, see: [🔗 “Using the Optional Heavy Roll Media Feeding Unit” on page 53](#)

#### When the Standard Media Feeding Unit Is Installed

This section describes how to load media when the standard media feeding unit is installed.

**⚠ Caution:**

Because the media is heavy, it should not be carried by one person. When loading or removing the media, use at least two persons.

- 1 Remove the media holding plates, if installed.

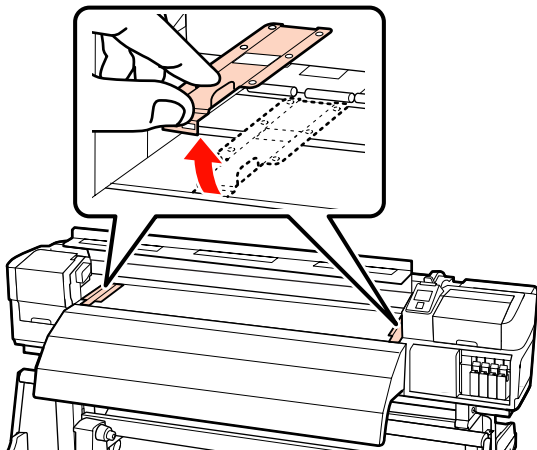

- 2 Turn on the printer by pressing the ⏻ button.

- 3 Loosen the roll holder fixing screws sufficiently and adjust the roll holders so that the distance between the two is wider than the media.

Center the roll supports between the roll holders.

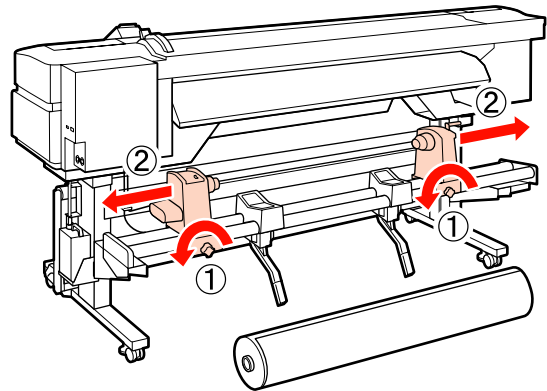

**⚠ Important:**

If the right holder handle shaft is not visible, rotate the holder forward until it stops. The media can not be properly loaded if the handle shaft is not visible.

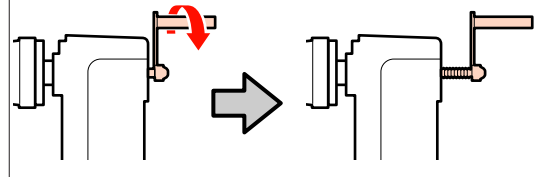

- 4 Place media on the roll support oriented according to how it is rolled (see below) and position it as indicated by the mark on the label.

**Printable Side Out**

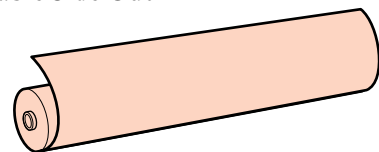



### Basic Operations

#### Printable Side In

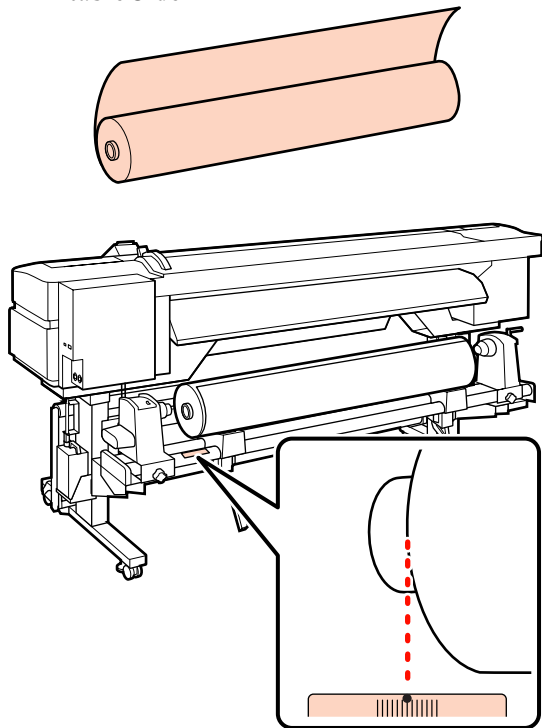

If the label does not have the loading position, mark it on the label as instructed in the *Setup Guide*.

 *Setup Guide*

- 5** Raise the lift lever on the left side of the printer to lift the media into position, then firmly insert the roll holder.

If the roll of media has the outer diameter which is less than 140mm, lift it up by your hands, and set it to the roll holder. The roll core will not reach the holder when raised using the lift lever.

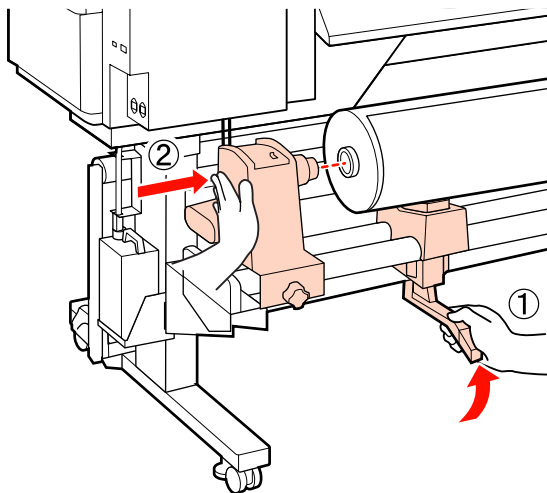

- 6** Tighten the roll holder screw until the screw no longer turns to fix the roll holder in place.

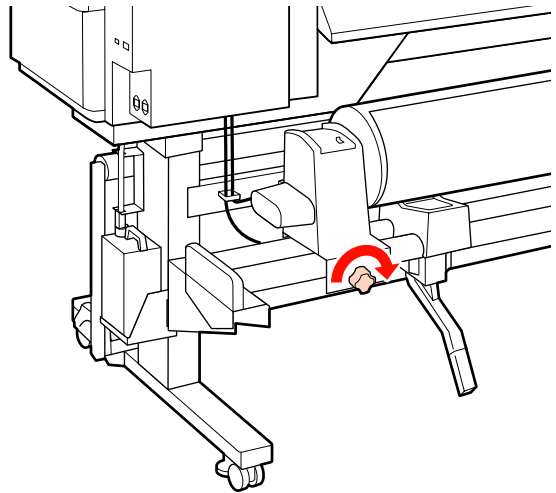

- 7** Raise the lift lever on the right side of the printer to lift the media into position, then firmly insert the roll holder.

If the roll of media has the outer diameter which is less than 140mm, lift it up by your hands, and set it to the roll holder as described in Step 5.

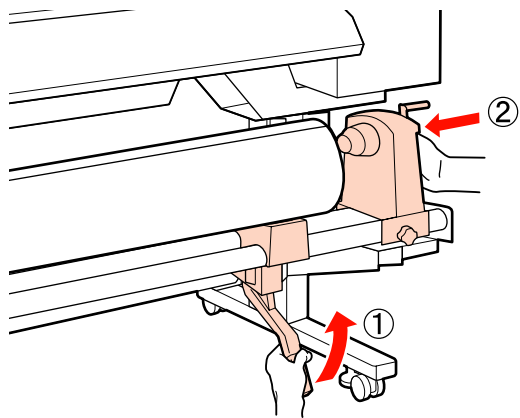

### Basic Operations

- 8** To ensure the roll holder is inserted into the roll core sufficiently, push the center section on the side of the roll holder towards the roll end twice.

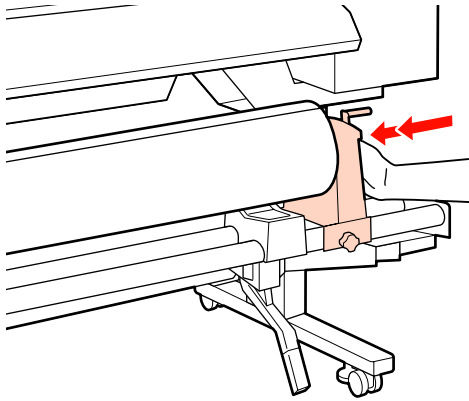

**! Important:**  
 If the roll holder is inserted into the roll core insufficiently, media is not fed correctly during printing because of slippage between the roll holder and roll core.  
 This may cause banding in the print results.

- 9** Tighten the roll holder screw until the screw no longer turns to fix the roll holder in place.

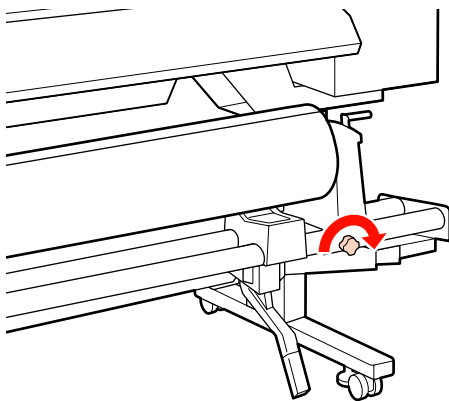

**! Important:**  
 If the roll holder screw is loose, the roll holder may move during printing. This could cause stripes and unevenness in the print results.

- 10** Rotate the handle until part A in the illustration below is fully inserted.

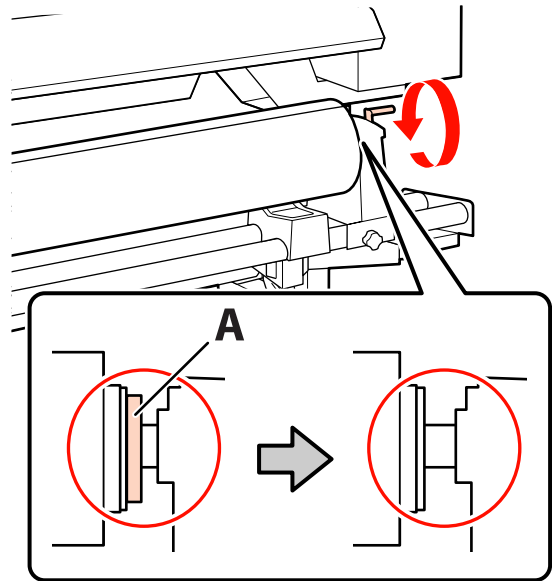

**! Important:**  
 Once part A is hidden, do not turn the handle any further. Failure to observe this precaution could damage the roll holder.  
 If part A is still visible even after the handle has been turned fully, rewind the handle. Loosen the roll holder screw on the right side, and then restart from Step 8.

- 11** Confirm that the right and left edges of the attached roll are aligned.

If the right and left edges of the role are not aligned, realign them.

- 12** Raise the media loading lever.

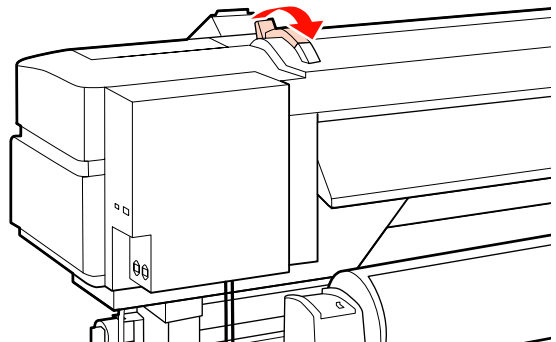

### Basic Operations

- 13** Pull out the media and insert it into the printer.

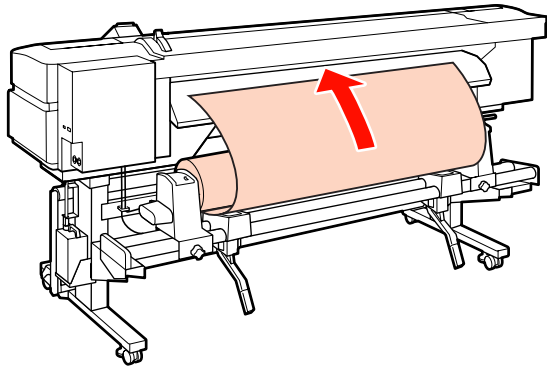

**Note:**

Media that is heavy and difficult to unroll can be fed by pressing the drive switch on the left roll holder.

Printable Side Out 

Printable Side In 

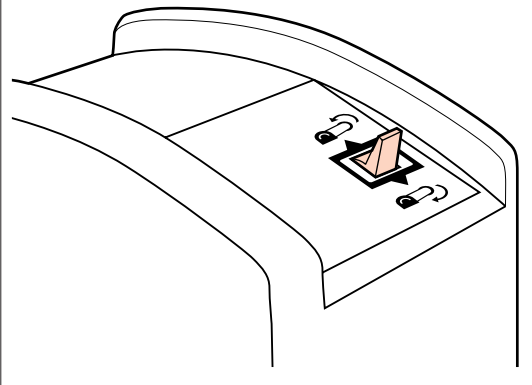

- 14** Insert the media past the pressure rollers and lower the media loading lever to hold it in place.

Confirm that the left edge of the media passes over the center of the square in the label on the pre-heater.

**! Important:**

Perform Steps 14 to 4 in reverse order and repeat the loading process if the left edge of the media is not within the guides. Do not attempt to reposition the roll holders while they are inserted in the media.

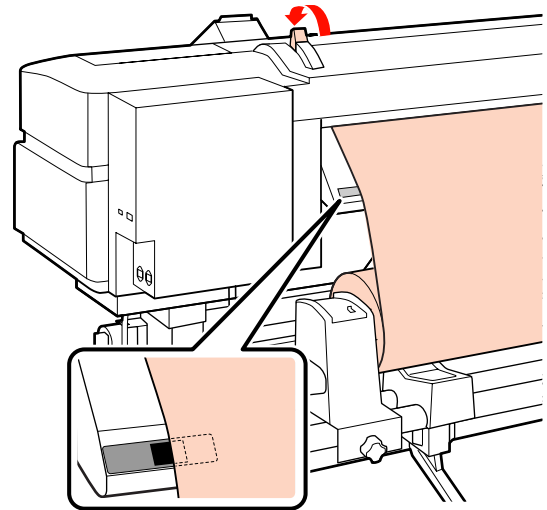

- 15** Go to the front of the printer and open the front cover.

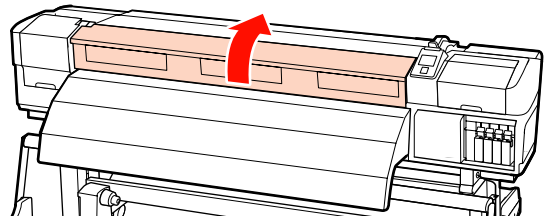

- 16** Hold the center of the media and raise the media loading lever.

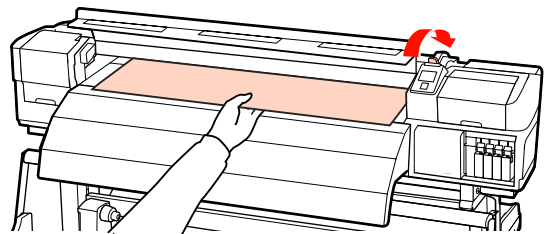

- 17** Pull the media straight forward until the edge has past the label on the top side of the after heater.

If the media is pulled passed the specified position, rewind the media to the specified position. The button to rewind media depends on how the loaded media is rolled.

Printable Side Out: Press the ▲ button.

## Basic Operations

Printable Side In: Press the ▼ button.

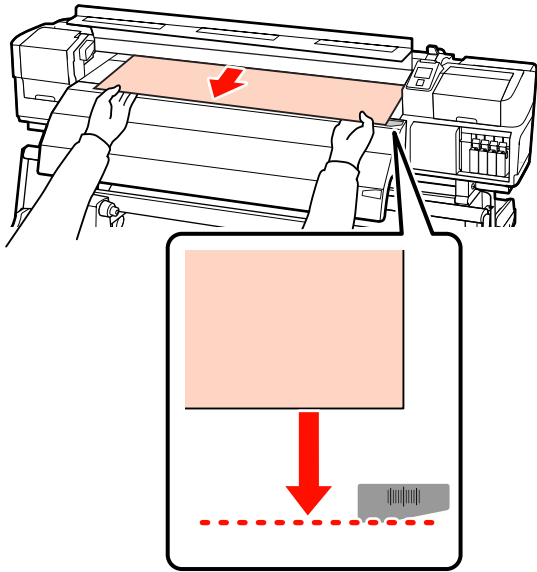

**!** **Important:**

*If the media loading process is continued with the media pulled past the specified position, there will be looseness in the media, which will result in the print head striking the media during printing.*

**18** Lower the media loading lever to hold the media in place.

To print immediately, proceed to Step 19.

For information on loading the media into the auto take-up reel unit, see:

[👉 “Using the Auto Take-up Reel Unit” on page 62](#)

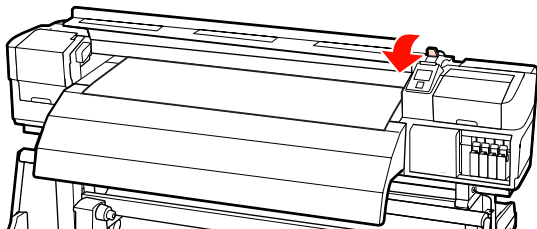

**19** Attach the media holding plates.

First, position the plates so that the edges of the media are at the centers of the round holes.

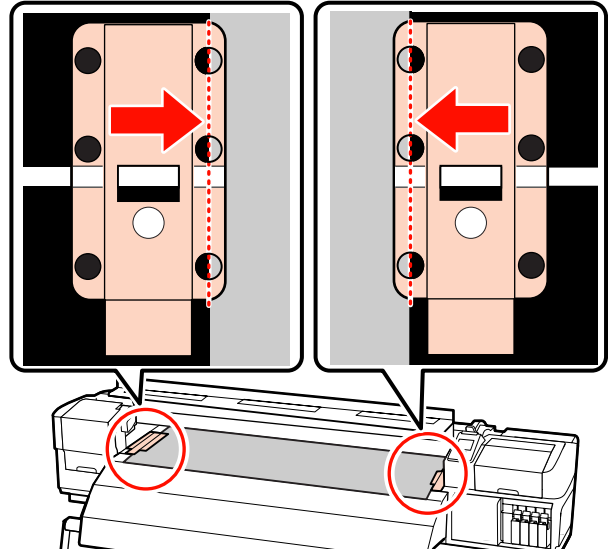

**!** **Important:**

*Always position the plates so that the edges of the media are at the centers of the round holes. Incorrect positioning causes banding (horizontal banding, lines, or strips of uneven color) during printing.*

## Basic Operations

- 20** Align the white lines of the plates with the white lines of the platen and push the plates down to lock them in place and keep them from lifting.

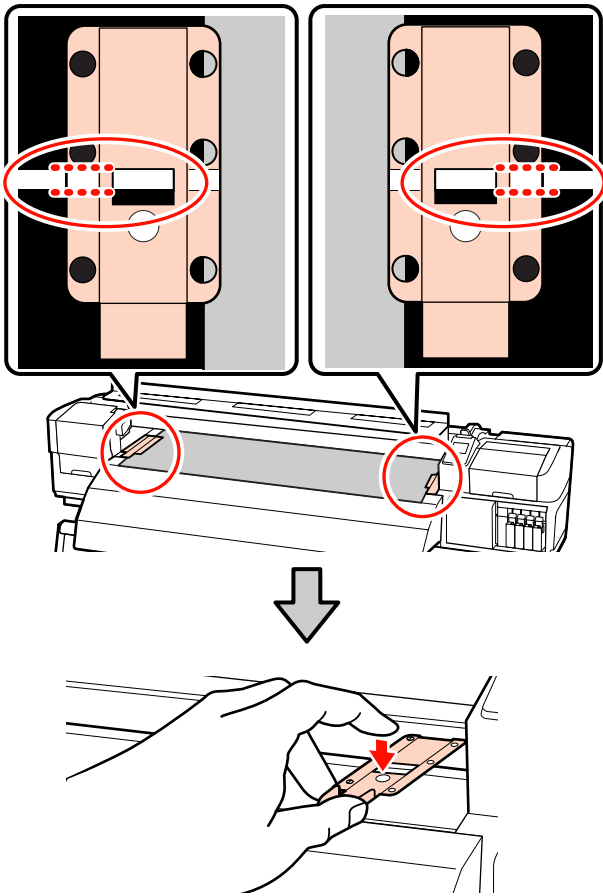

**! Important:**

- ❑ Do not use the media holding plates with media that is 0.4 mm or more thick. The media holding plates could touch and damage the print head.
- ❑ Move the media holding plates to the left and right edges of the platen when they are not in use.
- ❑ Do not use the media holding plates if the sides of the printed media are smudged or torn.

- 21** Close the front cover.

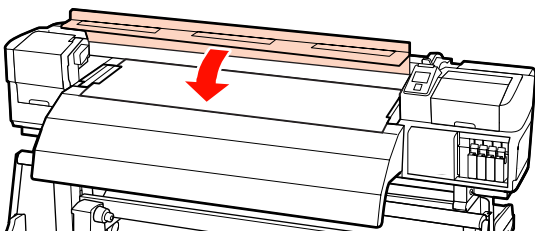

## Using the Optional Heavy Roll Media Feeding Unit

This section describes how to load media when the optional heavy roll media feeding unit is installed.

Using a lifter is recommended when handling a media that is 40 kg or heavier.

The explanation that follows assumes that a lifter is used.

The following types of lifter can be used.

- ❑ Fork or platform thickness: 28 mm or less
- ❑ Fork or platform can be lowered to approx. 190mm from the floor.



**Caution:**

*Because the media is heavy, it should not be carried by one person. When loading or removing the media, use at least two persons. Using a lifter is recommended when handling a media that is 40 kg or heavier.*

**1**

Remove the media holding plates, if installed.

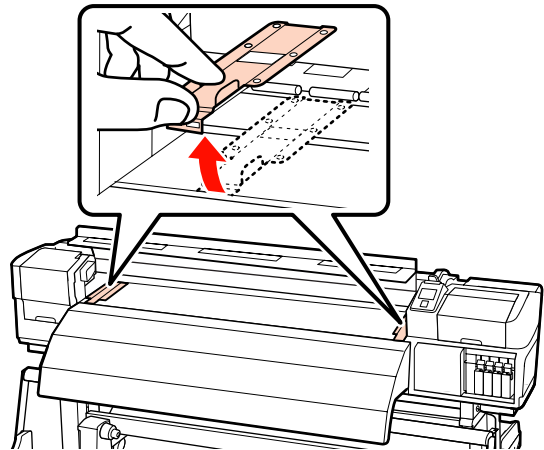

**2**

Turn on the printer by pressing the  button.

### Basic Operations

- 3** Loosen the left and right roll holder fixing screws sufficiently and separate the roll holders so that the distance between them is wider than the media.

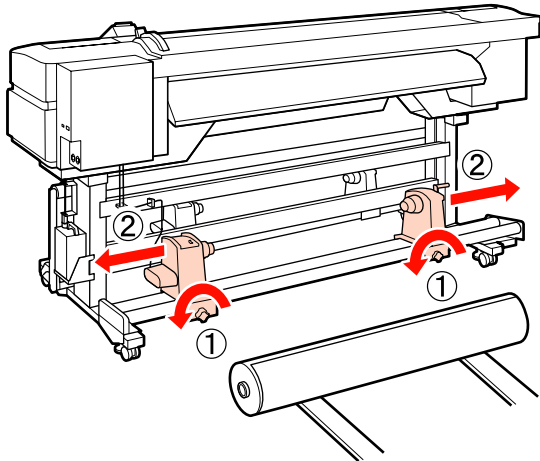

**! Important:**  
 If the right holder handle shaft is not visible, rotate the holder forward until it stops. The media can not be properly loaded if the handle shaft is not visible.

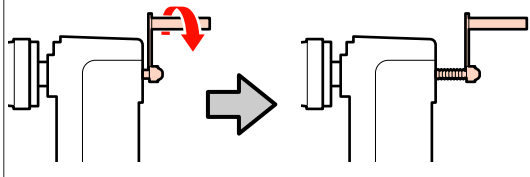

- 4** Place the media on a lifter oriented according to how it is rolled (see below) and move the lift to position the media as indicated by the mark on the label.

#### Printable Side Out

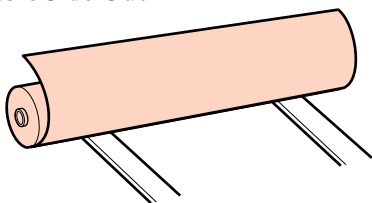

#### Printable Side In

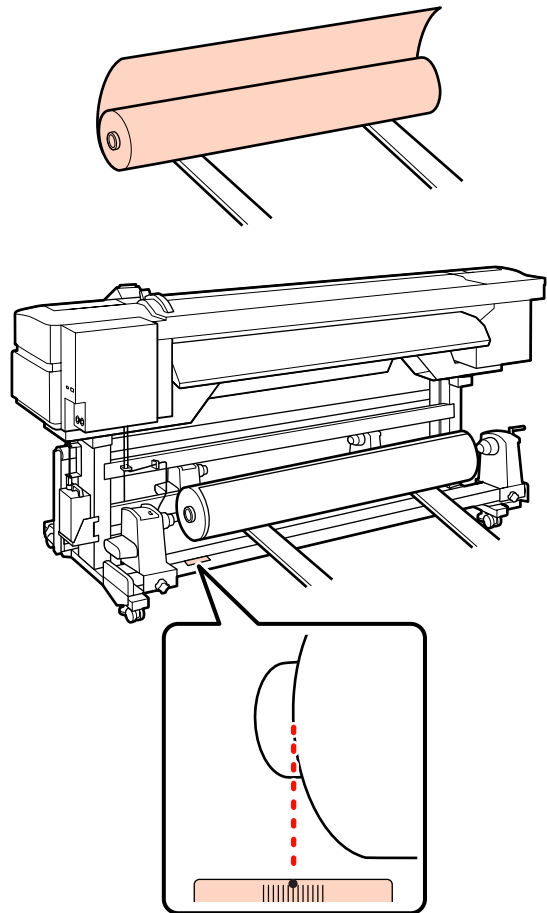

If the label does not have the loading position, mark it on the label as instructed in the *Setup Guide* supplied with the optional heavy roll media system.

*☞ Heavy Roll Media System Setup Guide*

- 5** Align the media and the roll holders.  
 Raise or lower the lifter until the media roll core is level with the roll holders.

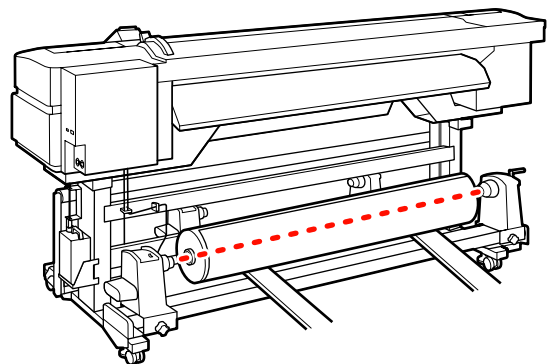

### Basic Operations

- 6** Fully insert the left roll holder. Next, tighten the roll holder screw until the screw no longer turns to fix the roll holder in place.

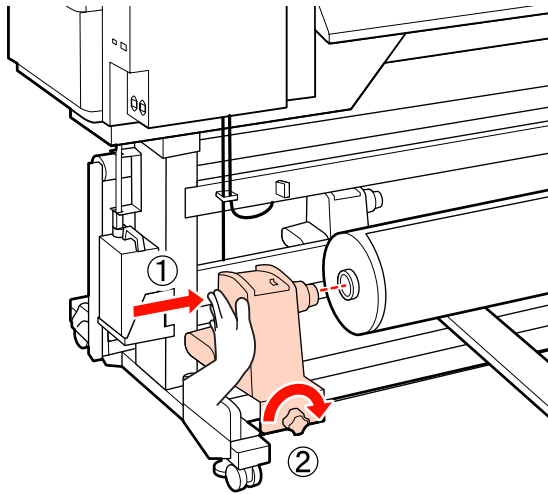

- 7** Fully insert the right roll holder.

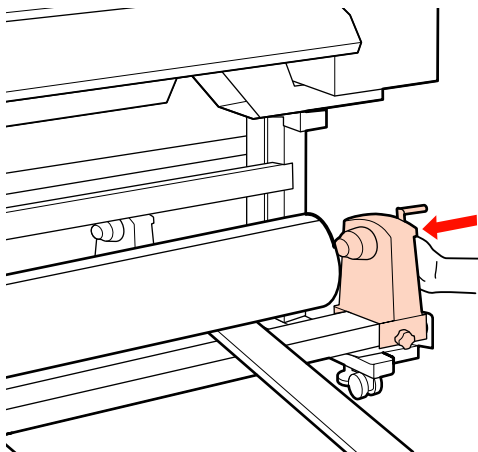

- 8** To ensure the roll holder is inserted into the roll core sufficiently, push the center section on the side of the roll holder towards the roll end twice.

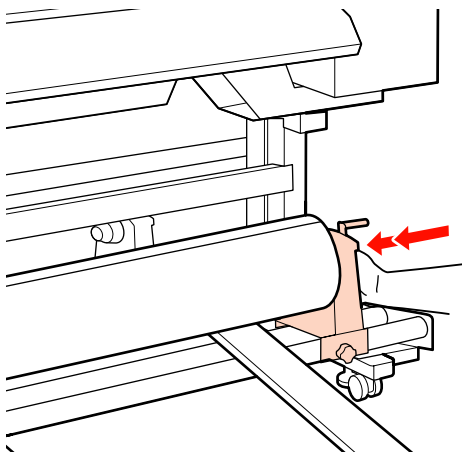

**! Important:**

*If the roll holder is inserted into the roll core insufficiently, media is not fed correctly during printing because of slippage between the roll holder and roll core.*

*This may cause banding in the print results.*

- 9** Tighten the roll holder screw until the screw no longer turns to fix the roll holder in place.

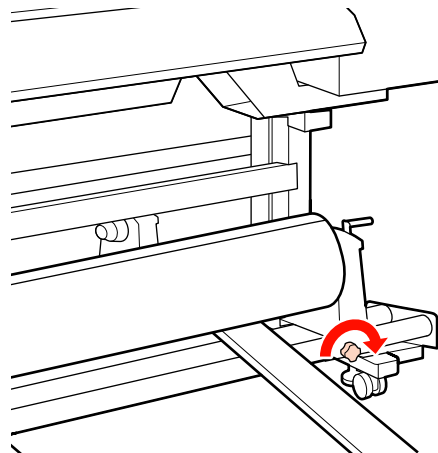

**! Important:**

*If the roll holder screw is loose, the roll holder may move during printing. This could cause stripes and unevenness in the print results.*

- 10** Remove the lifter.

## Basic Operations

- 11** Rotate the handle until part A in the illustration below is fully inserted.

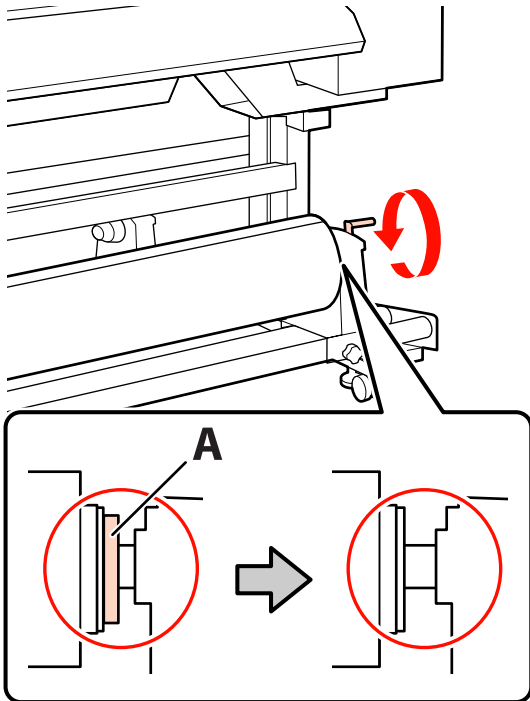

**! Important:**

Once part A is hidden, do not turn the handle any further. Failure to observe this precaution could damage the roll holder.

If part A is still visible even after the handle has been turned fully, rewind the handle. Loosen the roll holder screw on the right side, and then restart from Step 7.

- 12** Confirm that the right and left edges of the attached roll are aligned.

If the right and left edges of the role are not aligned, realign them.

- 13** Raise the media loading lever.

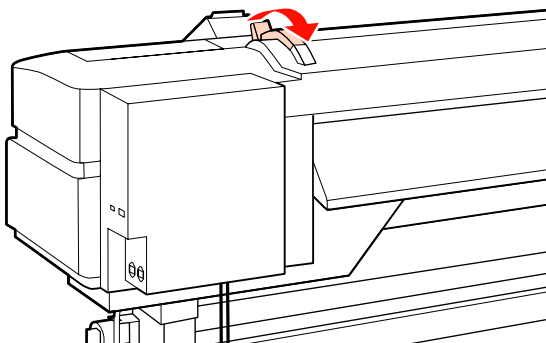

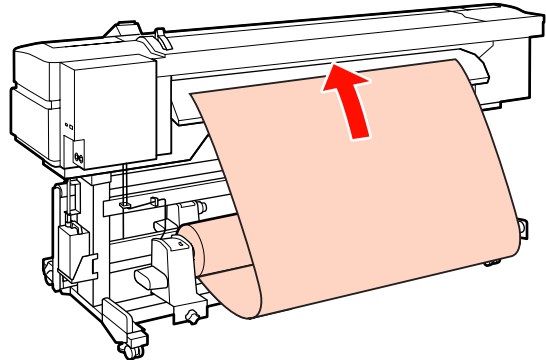

- 14** Pull out the media and insert it into the printer.



**Note:**

Media that is heavy and difficult to unroll can be fed by pressing the drive switch on the left roll holder.

Printable Side Out 

Printable Side In 

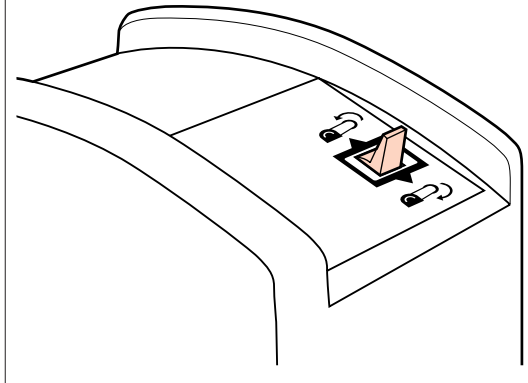

- 15** Insert the media past the pressure rollers and lower the media loading lever to hold it in place.

Confirm that the left edge of the media passes over the center of the square in the label on the pre-heater.

**! Important:**

Perform Steps 15 to 4 in reverse order and repeat the loading process if the left edge of the media is not within the guides. Do not attempt to reposition the roll holders while they are inserted in the media.



**Basic Operations**

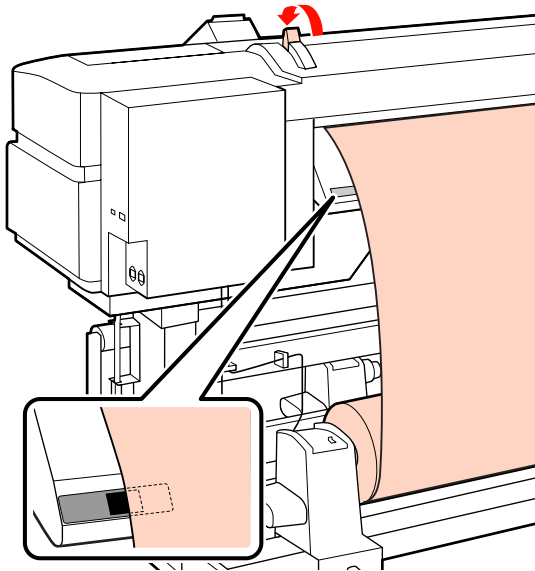

**16** Go to the front of the printer and open the front cover.

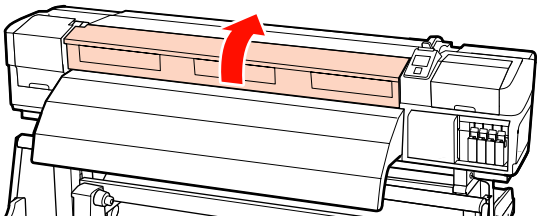

**17** Hold the center of the media and raise the media loading lever.

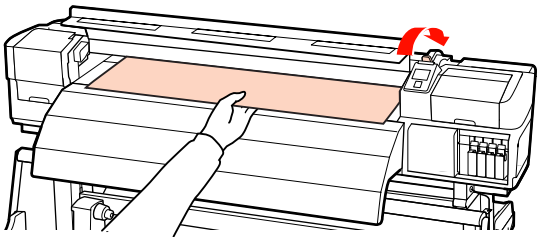

**18** Pull the media straight forward until the edge has past the label on the top side of the after heater.

If the media is pulled passed the specified position, rewind the media to the specified position. The button to rewind media depends on how the loaded media is rolled.

Printable Side Out: Press the ▲ button.

Printable Side In: Press the ▼ button.

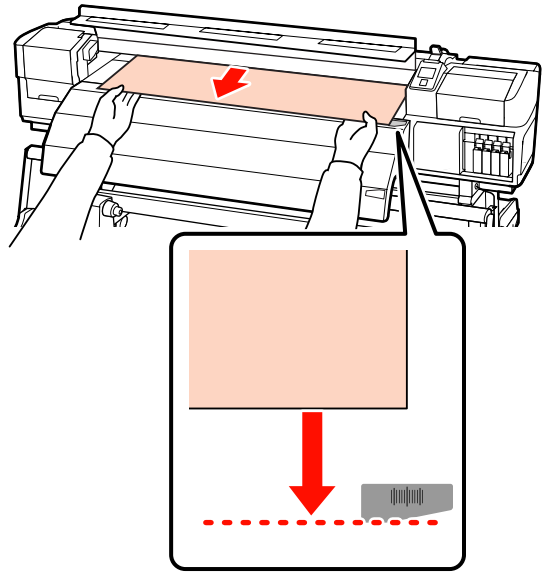

**! Important:**

*If the media loading process is continued with the media pulled past the specified position, there will be looseness in the media, which will result in the print head striking the media during printing.*

**19** Lower the media loading lever to hold the media in place.

To print immediately, proceed to Step 20.

For information on loading the media into the auto take-up reel unit, see:

[👉 “Using the Auto Take-up Reel Unit” on page 62](#)

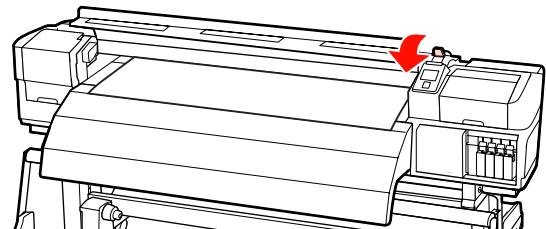

### Basic Operations

#### 20 Attach the media holding plates.

First, position the plates so that the edges of the media are at the centers of the round holes.

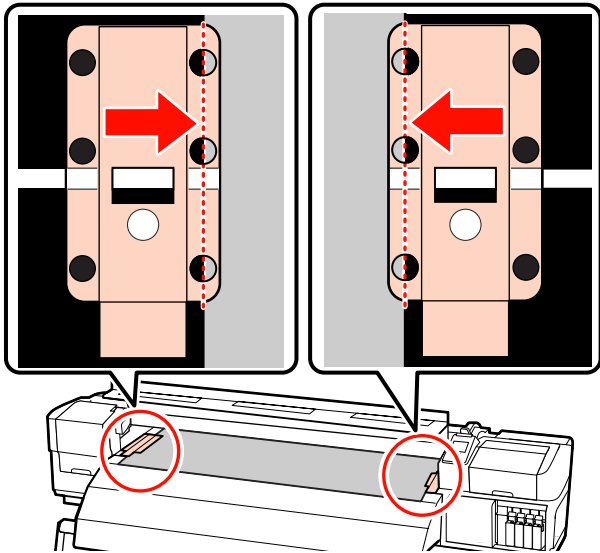

**Important:**

Always position the plates so that the edges of the media are at the centers of the round holes. Incorrect positioning causes banding (horizontal banding, lines, or strips of uneven color) during printing.

#### 21 Align the white lines of the plates with the white lines of the platen and push the plates down to lock them in place and keep them from lifting.

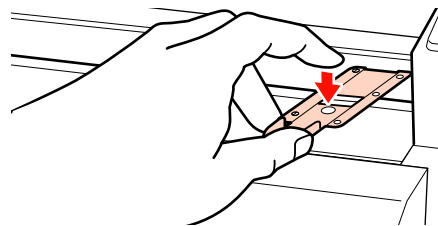
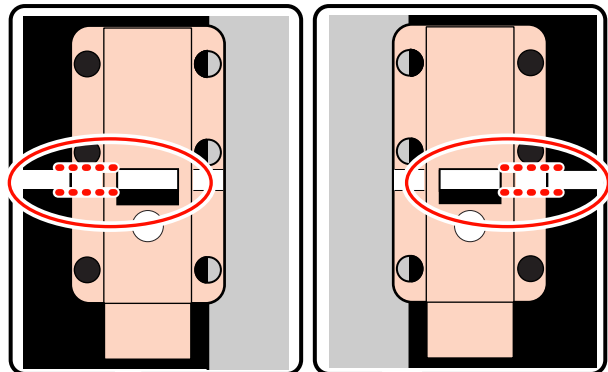

**Important:**

- ❑ Do not use the media holding plates with media that is 0.4 mm or more thick. The media holding plates could touch and damage the print head.
- ❑ Move the media holding plates to the left and right edges of the platen when they are not in use.
- ❑ Do not use the media holding plates if the sides of the printed media are smudged or torn.

#### 22 Close the front cover.

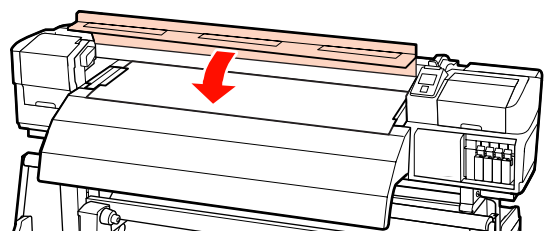

**Basic Operations**

**Viewing and Changing Media Settings**

The control panel displays the following information once the media is loaded.

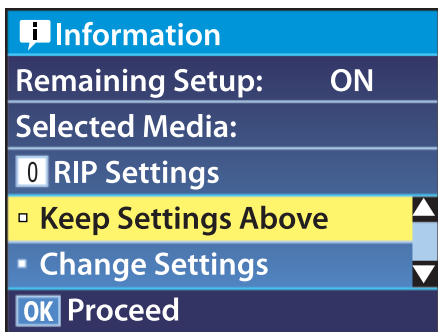

This display can be used to view or change the following two options:

Remaining Setup

**On:** The printer displays the amount of media remaining.

**Off:** The printer does not display the amount of media remaining.

When **Remaining Setup** is **On**, the printer will calculate the approximate amount of media remaining based on the length of the roll and the amount used for printing and display this information in the control panel. The display gives a rough idea of the amount of media available before printing, making it easier to know when media requires replacement.

In addition, a warning will be displayed when the amount of media remaining reaches a specified level.

Selected Media

Displays the parameters on which media settings are based as shown below.

**0 RIP Settings:** Media settings are based on those in the RIP.

**1 XXXXXXXXXXXXXXXXXXXX:** Media settings are based on those stored in the printer in media settings bank No. 1.

Media settings banks can store a variety of settings for different media based on the options selected in the **Heater Temperature, Media Suction, Head Alignment**, and other menus. Up to 30 combinations of settings can be stored by assigning them to banks No. 1 to 30.

Media Settings [“Saving Settings” on page 70](#)

Buttons that are used in the following settings

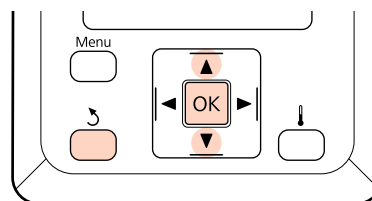

**1** Select an option.

**To print at current settings:**

Use the **▼/▲** buttons to select **Keep Settings Above** and press the **OK** button.

Proceed to Step 6.

**To change settings:**

Use the **▼/▲** buttons to select **Change Settings** and press the **OK** button.

**2** Select the items you want to change and press the **OK** button.

**3** Select the desired option and press the **OK** button.

**4** Press the **↵** button to display the dialog shown in Step 2 and then press the **↵** button again.

## Basic Operations

- 5 After confirming that the settings are correct, use the ▼/▲ buttons to select **Keep Settings Above** and press the OK button.
- 6 The roll type selection screen appears.  
Use the ▼/▲ buttons to select the roll type that matches the loaded roll and press the OK button.
- 7 If **On** is selected for **Remaining Setup**, you will be prompted to enter the length of the current media.  
Use the ▼/▲ buttons to choose a length between 1.0 and 999.5 m and press the OK button. You can set in 0.5m increments.

The printer will display **Ready** after a brief pause, showing that it is ready to print. Transmit the data to be printed from the computer.

## Exchanging Media

To replace the media after printing, print the amount of media remaining, cut the media, and remove the roll.

## Printing the Amount of Media Remaining

The printer displays the amount of media remaining and any media low warnings in the control panel. This makes it possible to determine whether the media requires replacement before printing.

The amount of media remaining can only be displayed if the correct length is entered when the media is loaded.

You can print the amount of media remaining on the leading edge of the roll before it is removed from the printer and then enter this number the next time the media is loaded for accurate information on the amount remaining.

### Note:

The printer does not calculate or display the amount of media remaining when **Off** is selected for **Remaining Setup** in the setup menu.

 ["Viewing and Changing Media Settings" on page 59](#)

The following section describes how to print the amount of media remaining.

Buttons that are used in the following settings

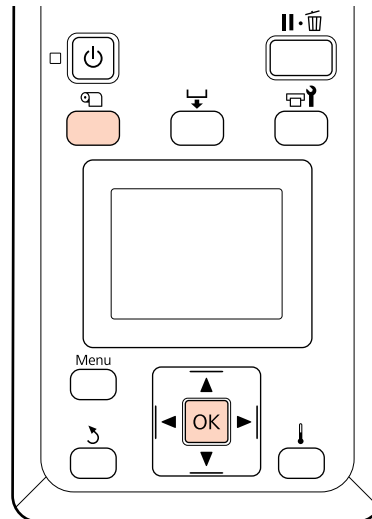

- 1 Confirm that the printer is ready to print.
- 2 Press the  button, select **Media Remaining** in the menu, and press the OK button.
- 3 Select **Print Remaining Length** and press the OK button.
- 4 Press the OK button to print the amount of media remaining.

## Cutting Media

Use a cutter (available in the market) to cut the media when printing is complete. This section described how to use a cutter to cut the media.



### Caution:

- The heaters and media holding plate may be hot; observe all necessary precautions. Failure to observe the necessary precautions could result in burns.
- When cutting media, be careful not to cut your fingers or hands with the cutter or other blades.

## Basic Operations

Buttons that are used in the following settings

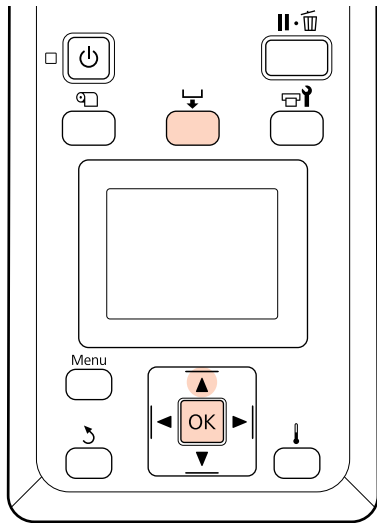

**1** Confirm that the printer is ready to print.

**2** Press the  button and the OK button. The printer will feed the trailing edge of the printed media to a position over the cutter groove.

If you have printed the amount of media remaining, press the  button to rewind the media so that this information will remain on the roll after the media is cut.

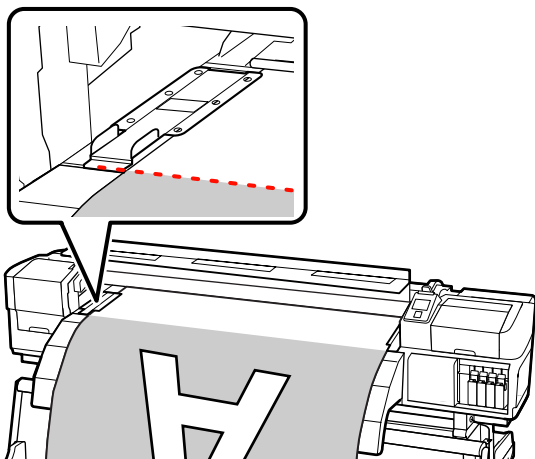

**3** Remove the media holding plates.

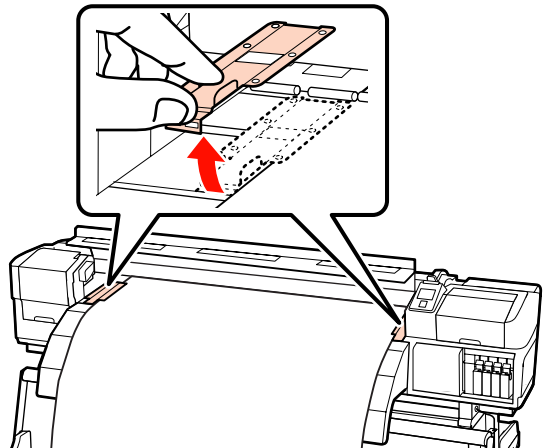

**4** Cut the media with the cutter.

Pass the blade of the cutter down the cutting groove.

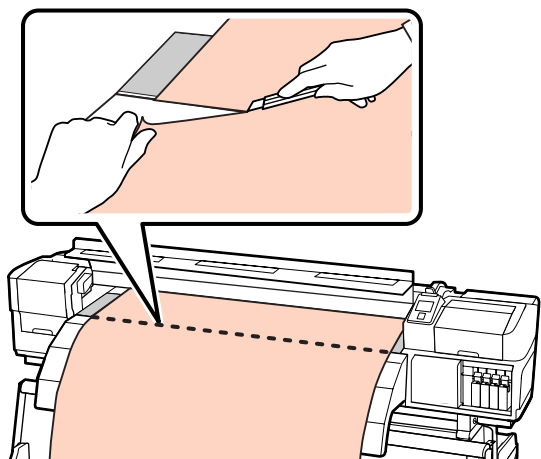

**Note:**

- If you are using the auto take-up reel unit, set the Auto switch on the auto take-up reel unit to Off before using the Manual switch to position the media over the cutting groove.
- If you are using the SC-S70600 series or SC-S50600 series and do not intend to make additional prints, raise the media loading lever to prevent deformation of the pressure rollers.

### Removing Media

You can now remove the media from the roll holders. To remove the media, reverse the steps you followed to load it.

## Basic Operations

## Using the Auto Take-up Reel Unit

### Media Loading

The auto take-up reel unit automatically takes up media as it is printed, improving the efficiency of unmanned operation.

The auto take-up reel unit for this printer can take up media in either of the following directions.

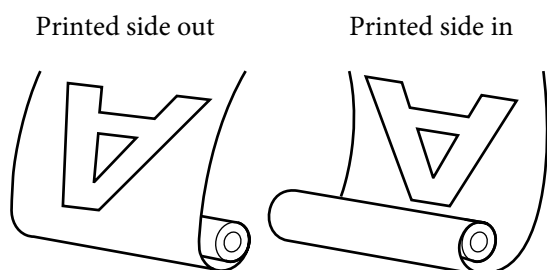

Taking-up with printed side out places the printed surface on the outside of the roll.

Taking-up with printed side in places the printed surface on the inside of the roll.

The explanation that follows uses the supplied auto take-up reel unit for illustrative purposes, but the same procedure can be followed when using the optional auto take-up reel unit for heavy media.

#### **Caution:**

- ❑ Be sure that your hands or hair do not get caught in the auto take-up reel unit while it is in operation.

*Failure to observe this precaution could result in injury.*

- ❑ Follow the instructions in the manual when loading media or roll cores or removing media from the take-up roll.

*Dropping media, roll cores, or take-up rolls could result in injury.*



#### **Important:**

Note that the auto take-up reel unit may not function as expected when ink layering is performed with the SC-S70600 series or SC-S50600 series, causing a decline in print quality.

Ink layering ↻ “High Print Quality” on page 23

### Attaching the Roll Core

1

Before attaching the media to the auto take-up reel unit, cut the left and right corners of the media edges as shown below.

Cutting the media prevents feeding problems, such as the left and right corners of media being folded and caught at the start of take-up.

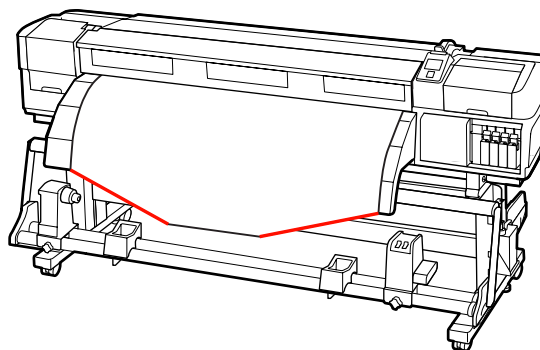

2

After confirming that the media is loaded correctly, press the ▼ button to feed the media as far as the auto take-up reel unit roll core holder.

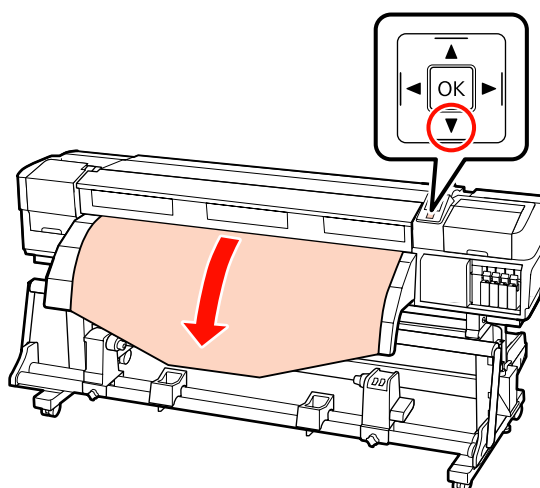

### Basic Operations

**! Important:**

Always press the ▼ button to feed the media as far as the roll core holder. If the media is pulled by hand, the media may twist during take-up.

- 3** Loosen the roll core holder fixing screws and adjust the roll core holders so that the gap between the two is wider than the media. Center the roll supports between the roll holders.

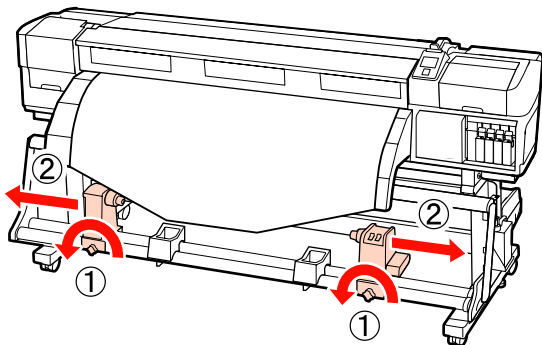

- 4** Align the right roll core holder with the right edge of the media and tighten the fixing screw.

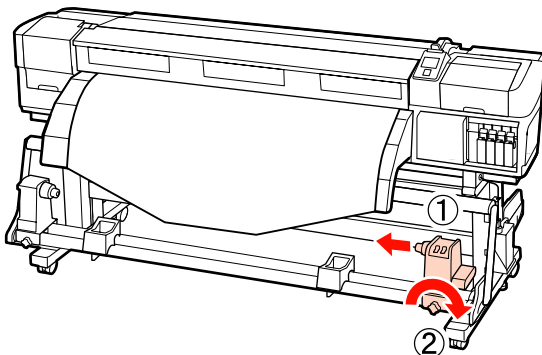

- 5** Insert the roll core onto the right holder.

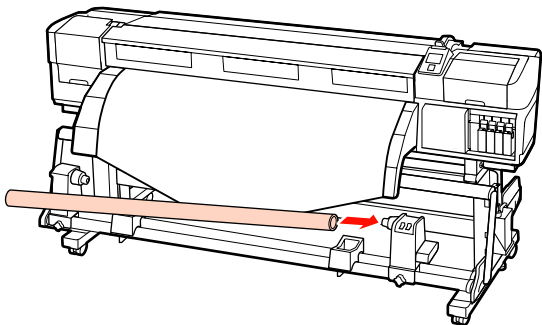

- 6** Insert the left holder into the roll core. Slide the holder in until part A in the illustration below is fully inserted.

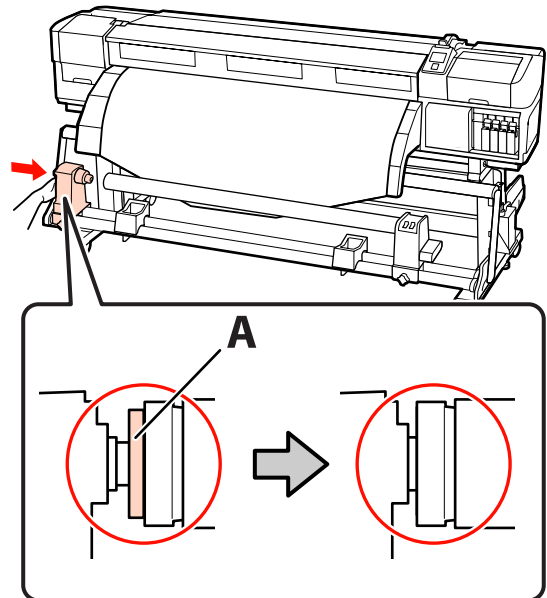

**! Important:**

Stop when part A is no longer visible. The take-up reel unit may not function as expected if the holder is inserted too far.

- 7** Tighten the roll core holder fixing screw to fix the roll core holder in place.

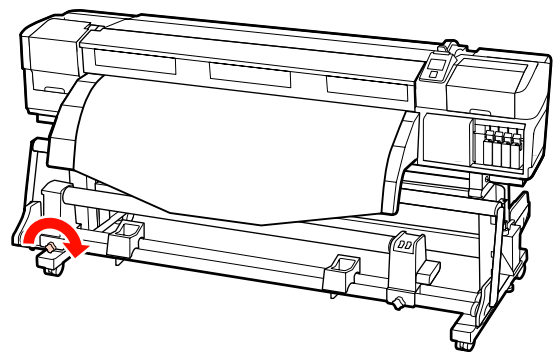

See the following for further instructions.

For information on taking-up with printed side out, see the following section.

For information on taking-up with printed side in, see [“Take-up with the Printed Side Facing In”](#) on page 65.

## Basic Operations

### Take-up with the Printed Side Facing Out

- 1 While pulling the center section of the media straight down, affix the media to the take up roll core with tape.

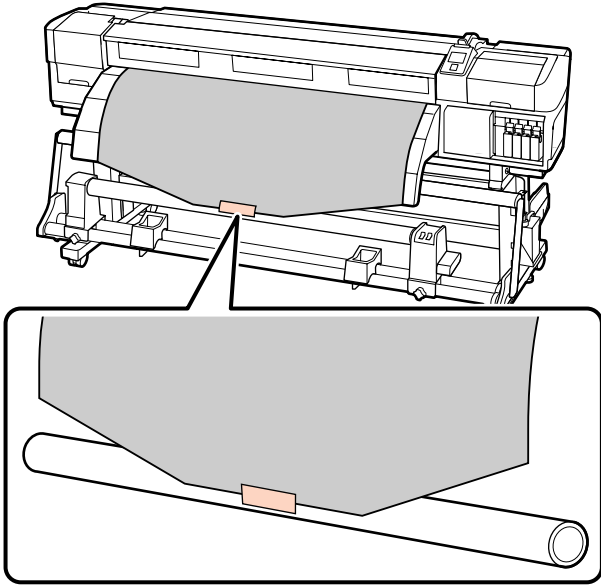



**!** **Important:**

Attach the media to the take up roll core with the media in a taut state. If media is attached in a loose state, the media may move around during take-up.

- 2 Press the ▼ button in the control panel to feed enough media for a single wrap around the roll core.

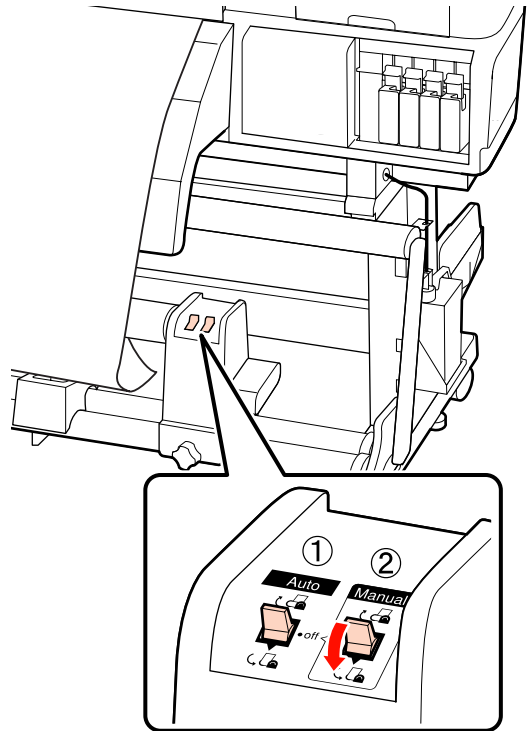
- 3 Flip the Auto switch to Off and press the Manual switch to  to wrap the media once around the roll core.



- 4 Flip the Auto switch to  .

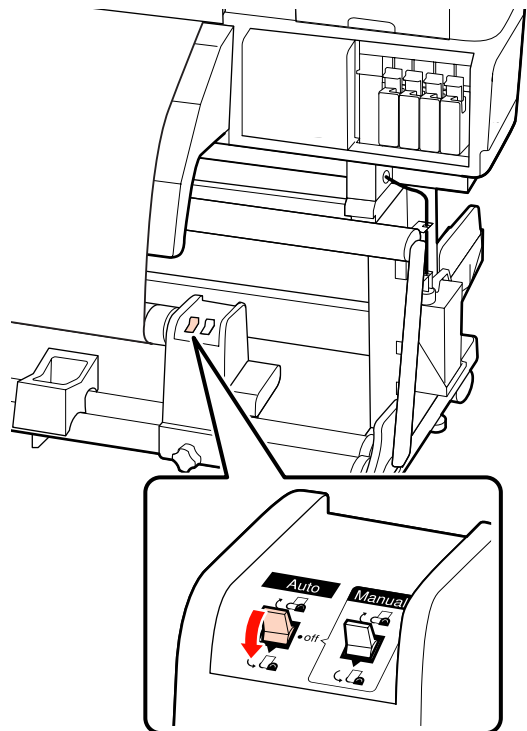



## Basic Operations

- 5** Lower the tensioner.

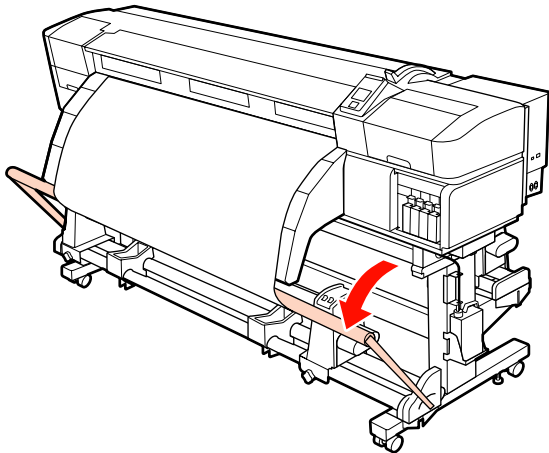

- 6** Confirm that the media is attached without looseness.

If the tension on the left and right of the media is different in the areas shown in the illustration below, the media will not be taken up correctly. When one side is loose, restart the procedure from Step 1.

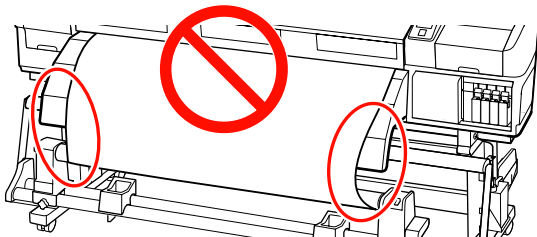

**Note:**

You can confirm differences in tension by lightly tapping both edges of the media as shown in the illustration below.

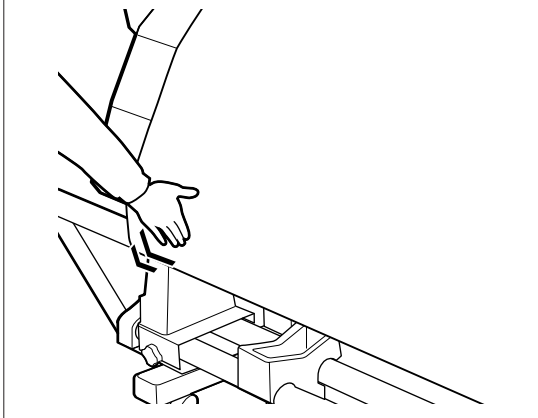

- 7** Press the ▼ button to feed the media until the take up roll core begins to turn.

**! Important:**

The auto take-up reel unit will not function if the tensioner is raised.

### Take-up with the Printed Side Facing In

- 1** While pulling the center section of the media straight down, affix the media to the take up roll core with tape.

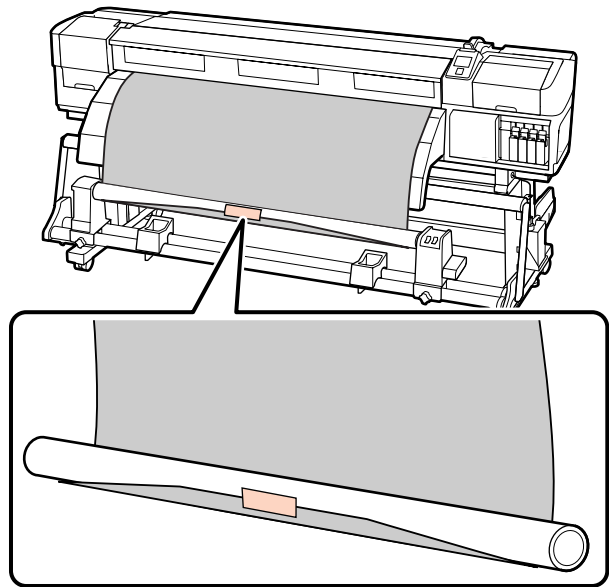

**! Important:**

Attach the media to the take up roll core with the media in a taut state. If media is attached in a loose state, the media may move around during take-up.

- 2** Press the ▼ button in the control panel to feed enough media for a single wrap around the roll core.

## Basic Operations

- 3** Flip the Auto switch to Off and press the Manual switch to wrap the media once around the roll core.

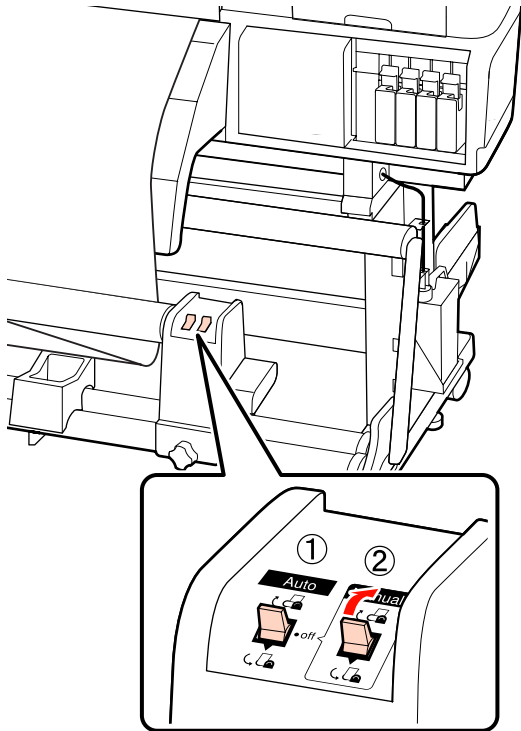

- 4** Flip the Auto switch to .

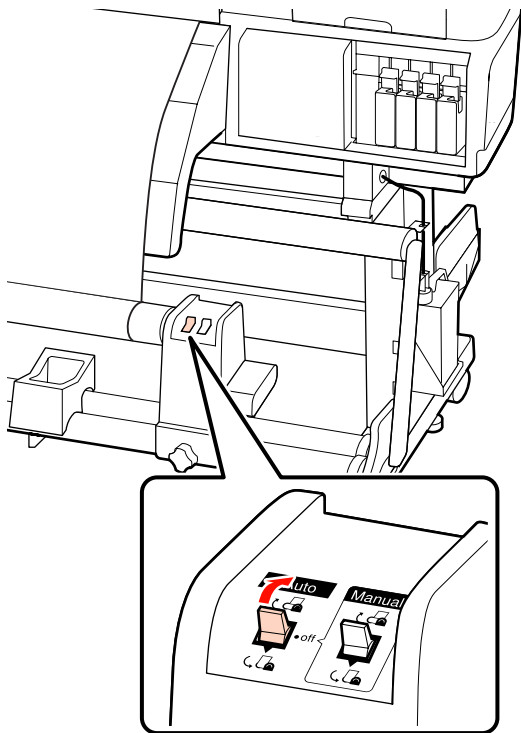

- 5** Lower the tensioner.

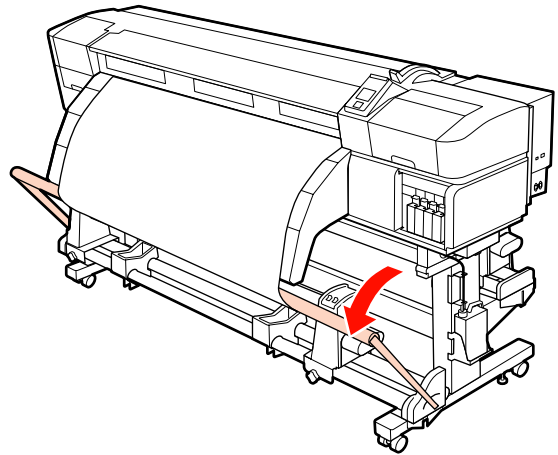

- 6** Confirm that the media is attached without looseness.

If the tension on the left and right of the media is different in the areas shown in the illustration below, the media will not be taken up correctly. When one side is loose, restart the procedure from Step 1.

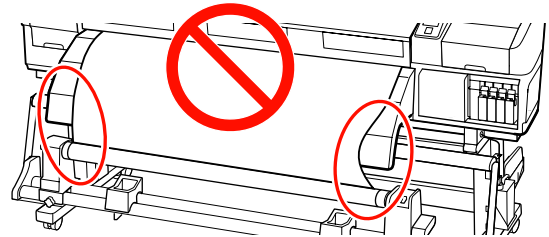

**Note:**

You can confirm differences in tension by lightly tapping both edges of the media as shown in the illustration below.

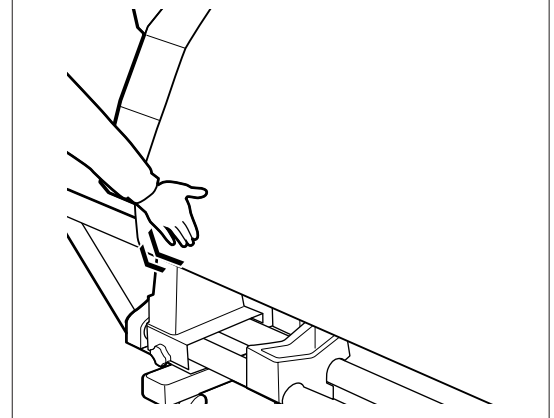

## Basic Operations

- 7 Press the ▼ button to feed the media until the take up roll core begins to turn.

**! Important:**  
The auto take-up reel unit will not function if the tensioner is raised.

## Counterweight Loading

When a banner media has been loaded, attach the counterweights included with the printer on the tensioner, with three each on the left and right, before printing.

**! Important:**  
For other media types, always remove the counterweights before printing.  
Failure to do so may cause the print head to strike the media during printing.

Open the counterweight and attach it to the tensioner.

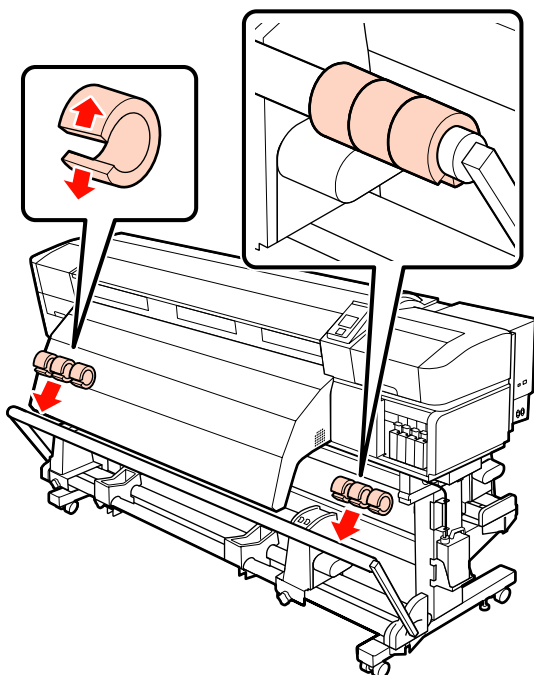

**! Important:**  
Always attach three each on the left and right. Take-up will not be performed correctly if counterweights are added to one side only or the quantities are different on the left and right.

## Removing the Take-up Roll

The procedure for removing media varies depending on whether you are using the supplied auto take-up reel unit or the optional auto take-up reel unit for heavy media.

Follow the steps below when using the supplied auto take-up reel unit.

When the Heavy Roll Auto Take-up Reel Unit is installed, see [“Using the Optional Heavy Roll Auto Take-up Reel Unit”](#) on page 68

## When the Standard Auto Take-up Reel Unit Is Installed

This section describes how to remove media from the take-up reel.

**! Caution:**

- ❑ Because the media is heavy, it should not be carried by one person. When loading or removing the media, use at least two persons.
- ❑ Follow the instructions in the manual when loading media or roll cores or removing media from the take-up roll.

Dropping media, roll cores, or take-up rolls could result in injury.

- 1 Cut the media and roll the cut end onto the take-up reel.  
[“Cutting Media”](#) on page 60
- 2 To prevent the media from sliding off the roll, support the roll at its left end.
- 3 Loosen the left roll core holder fixing screw and remove the roll core holder from the roll.

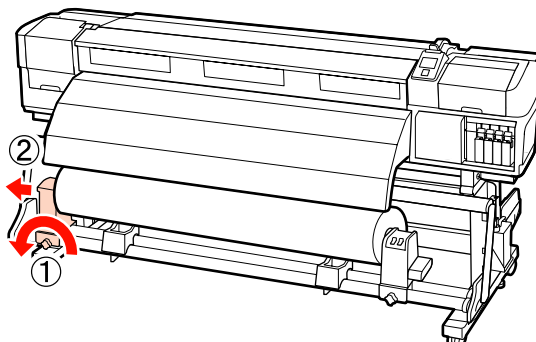

## Basic Operations

- 4** Lower the roll onto the roll support.

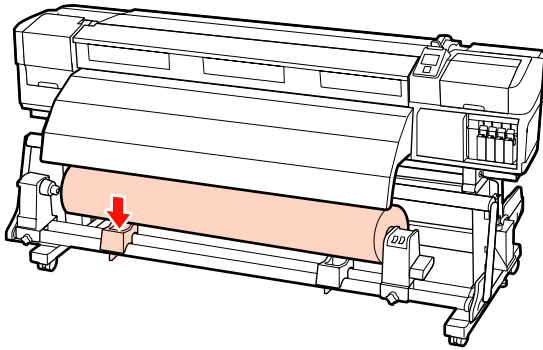

- 5** To prevent the media from sliding off the roll, support the roll at its right end.

- 6** Loosen the right roll core holder fixing screw and remove the roll core holder from the roll.

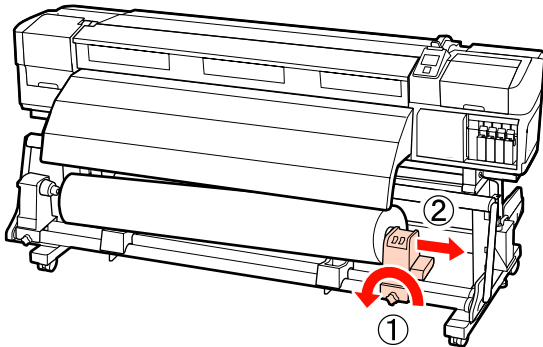

- 7** Lower the roll onto the roll support.

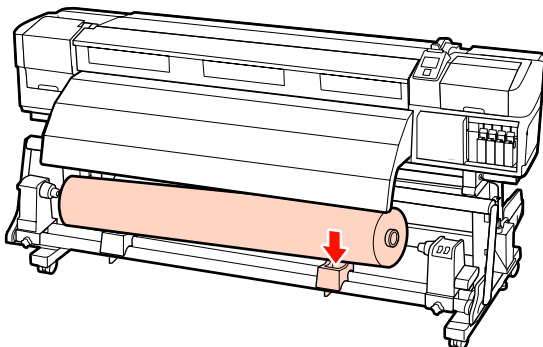

### Using the Optional Heavy Roll Auto Take-up Reel Unit

This section explains how to remove media from the take-up reel using a lifter.

The following types of lifter can be used.

- ❑ Fork or platform thickness: 28 mm or less

- ❑ Fork or platform can be lowered to approx.190mm from the floor.

#### **!** Caution:

- ❑ Because the media is heavy, it should not be carried by one person. When loading or removing the media, use at least two persons.  
Using a lifter is recommended when handling a media that is 40 kg or heavier.
- ❑ Follow the instructions in the manual when loading media or roll cores or removing media from the take-up roll.  
Dropping media, roll cores, or take-up rolls could result in injury.

- 1** Cut the media and roll the cut end onto the take-up reel.

 [“Cutting Media” on page 60](#)

- 2** Insert the lifter between the media and the auto take-up reel unit and adjust the height to support the take-up roll.

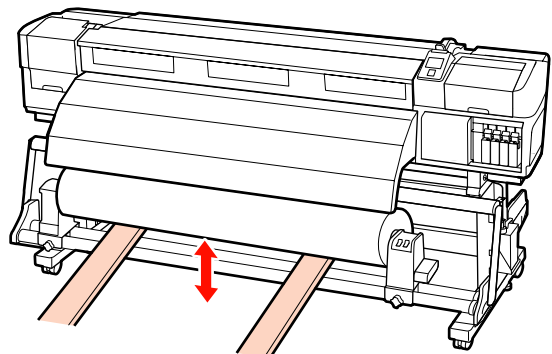

- 3** Loosen the left roll core holder fixing screw and remove the roll core holder from the roll.

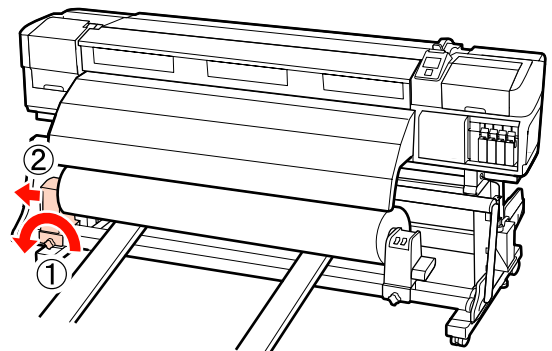

## Basic Operations

- 4** Loosen the right roll core holder fixing screw and remove the roll core holder from the roll.

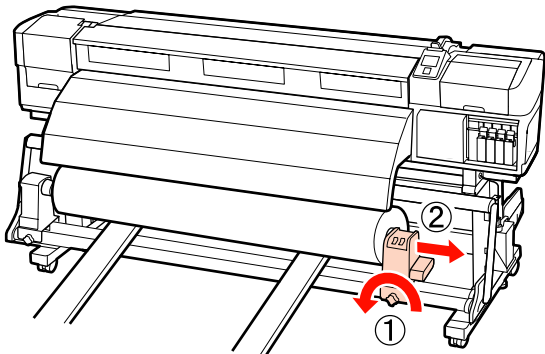

## Before Printing

To maintain print quality, perform the following inspection before starting work each day.

- Check the amount of ink remaining:

If ink is expended during printing, printing can be resumed once the affected cartridge has been replaced. However, when replacing ink during a print job, you may see a difference in color depending on the drying conditions. If you know that the print job will be a large one, we recommend that you use new cartridges to replace those that are running low before you start. The old cartridges can be reinserted and used at a later date.

Ink level is shown by an icon. [☞ “Understanding the Display” on page 20](#)

Replacing Ink Cartridges [☞ “Replacement and Shake Methods” on page 101](#)

- Shaking spot color inks

Spot color ink must be removed and shaken once every 24 hours. Although a message is displayed in the control panel 24 hours after the inks were last removed, we recommend that they be removed and shaken before the start of work.

Shaking ink cartridges [☞ “Replacement and Shake Methods” on page 101](#)

- Print Check Pattern

Print a check pattern to check for clogged nozzles.

Perform head cleaning if parts of the pattern are faint or missing.

Print a Check Pattern [☞ “Checking for clogged nozzles” on page 109](#)

Head Cleaning [☞ “Head Cleaning” on page 110](#)

## Saving Optimal Settings for the Current Media (Print Media Settings)

A variety of media settings can be optimized for the current media and stored in the printer.

Once frequently used settings have been stored in a media setting bank, it can be recalled to instantly optimize multiple parameters.

The printer offers a total of 30 media setting banks.

This section describes how to create media setting banks and the settings that can be stored.

---

## Parameters Stored in Media Setting Banks

Media setting banks store the following:

- Setting Name
- Feed Adjustment
- Platen Gap
- Head Alignment
- Heating & Drying
- Media Suction
- Head Movement
- Multi-Strike Printing
- Roll Type

## Basic Operations

- Tension Measurement
- Media Tension
- Feed Speed

For more information on these items, see [“The Media Setup Menu”](#) on page 120.

### Recommended values for leading media types

This section lists the recommended setting values when printing to leading media types.

Refer to these values when saving media settings.

#### SC-S70600 series, SC-S50600 series

	Adhesive vinyl Transparent film	Banner	Canvas
Platen Gap	1.5	1.5	1.5
Heater Temperature			
Pre-heater	40	40	40
Platen heater	40	40	40
After heater	50	50	50
Media Suction	4	4	4
Media Tension	15	15	15

#### SC-S30600 series

	Adhesive vinyl Transparent film	Banner	Canvas
Platen Gap	1.5	1.5	1.5
Heater Temperature			
Pre-heater	40	40	40
Platen heater	40	40	40
After heater	50	50	50
Media Suction	4	4	4

	Adhesive vinyl Transparent film	Banner	Canvas
Media Tension	15	30	15

## Saving Settings

Follow the steps below to save media settings.

Buttons that are used in the following settings

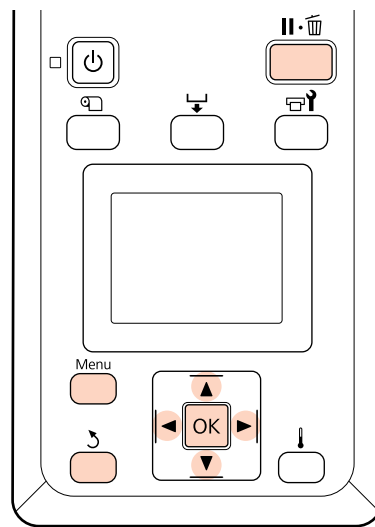

### Choosing a Media Setting Bank

- 1** After confirming that the printer is ready, press the **Menu** button.

The settings menu will be displayed.

- 2** Select **Media Setup** and press the OK button.

- 3** Use the ▼/▲ buttons to select **Customize Settings** and press the OK button.

- 4** Use the ▼/▲ buttons to select a media setting bank number between 1 and 30 and then press the OK button.

Note that any settings already saved in the printer will be overwritten.

## Basic Operations

### Setting Name

Name the media setting bank. Using distinctive names makes it easier to select banks for use.

- 1 Select **Setting Name** and press the OK button.
- 2 Use the ▼/▲ buttons to display letters and symbols. When the desired character is displayed, press the ► button to select the next entry position.  
  
Mistakes can be erased by pressing the ◀ button to delete the previous character and move the cursor back one spot.
- 3 After entering the name, press the OK button.

### Feed Adjustment

**Feed Adjustment** is used to correct banding (horizontal banding, lines, or strips of uneven color).

The **Feed Adjustment** menu contains two options: **Auto** and **Manual**.

Auto feed adjustment adjusts the feed automatically using data collected by a sensor while a test pattern is printed.

In manual feed adjustment, the user visually inspects print results and enters a correction by hand.

This section details the steps involved in auto feed adjustment.

Adjust the feed manually if you feel that auto feed adjustment has not completely resolved the problem.

For more information on manual feed adjustment, see [☞ “Feed Adjustment \(Manual Feed Adjustment\)” on page 77](#).

#### Notes on correct adjustment

The condition of media is important for correct feed adjustment.

Observe the following points when loading media.

- ❑ Feed adjustment varies with the media being used. Load the media for which feed adjustment is required under the same conditions as the actual print job. For example, if you are using the auto take-up reel unit for printing, the auto take-up reel unit should also be used for feed adjustment.

Furthermore, when installing the heavy roll media system, the media must be loaded and feed adjustment performed again, even if once you adjust with the standard roll media system.

- ❑ Feed adjustment is not available under the following conditions:
  - ❑ The media is transparent or colored.
  - ❑ The printer is exposed to direct sunlight or interference from other ambient light sources.  
  
Shade the printer from sources of interference.
  - ❑ 2.5 is selected for **Platen Gap** in the setup menu.  
  
Choose another option for **Platen Gap**.
  - ❑ Nozzles are clogged.  
  
Perform head cleaning to remove any clogs.

- ❑ Pull the media to the prescribed position before performing Feed Adjustment. Correct adjustment may not be possible if the media is not pulled sufficiently because the condition of the leading edge of the media may worsen due to waves or other issues.

Loading Media [☞ “Loading and Exchanging Media” on page 32](#)

- ❑ Do not perform feed adjustment on sections of media that have been fed and then rewound when using the SC-S70600 series or SC-S50600 series. Media that has been fed and then rewound may have traces or other issues from rollers and it may not be possible to adjust correctly.

#### Setting procedure

This section details the steps involved in auto feed adjustment.

## Basic Operations

- 1 Confirm that the media has been pulled to the prescribed position.  
  
Correct adjustment may not be possible if the media is not pulled sufficiently.  
  
Loading Media  “Loading and Exchanging Media” on page 32
- 2 Use the ▼/▲ buttons to select **Feed Adjustment** and press the OK button.
- 3 Select **Auto** and press the OK button.
- 4 Press the OK button to print a test pattern and perform auto feed adjustment.

### Platen Gap

Adjust the platen gap (the gap between the print head and the media) if print results are smudged.

- 1 Use the ▼/▲ buttons to select **Platen Gap** and press the OK button.
- 2 Use the ▼/▲ buttons to select the desired setting and press the OK button.
- 3 Press the ↵ button to return to the customize settings menu.



**Important:**

Select 2.5 only if print results are still smudged when 2.0 is selected. Choosing a larger gap than required may result in ink stains inside the printer, reduced print quality, or shorter product life.

### Head Alignment

Given that there is a slight gap between the print head and the media, the landing sites for the different colors of ink may be affected by humidity, temperature, inertial forces imparted by the print head, the direction of the print head as it moves from right to left or left to right, or the use of two print heads (all models except SC-S30600 series).

As a result, print results may appear grainy or out of focus. When this happens, perform **Head Alignment** to correct the print misalignment.

#### Head alignment types and execution sequences

Head Alignment can be performed automatically or manually. The following section describes each function.

##### Auto adjustment

Auto adjustment aligns the head automatically using data collected by a sensor while a test pattern is printed. Use this function in most situations.

##### Manual adjustment

In manual adjustment, check the pattern and enter the optimum adjustment value for alignment. Align the head manually if you feel that auto head alignment has not completely resolved the problem.

 “Head Alignment (Manual Adjustment)” on page 75

In both auto and manual adjustment, you can select the following adjustment methods.

##### Uni-D

Select for unidirectional printing.

##### Bi-D

Select for bidirectional printing.

##### Dual head (SC-S70600 series, SC-S50600 series only)

Select when graininess and misalignment cannot be removed after adjustment using either Bi-D or Uni-D. After using Dual Head, run Uni-D or Bi-D adjustment again.

#### Notes on correct adjustment

The condition of media is important for correct head alignment.

Observe the following points when loading media.

- Head Alignment varies with the media used. Load and adjust the media that will be used in the actual print job.
- Head alignment is not available under the following conditions:
  - The media is transparent or colored.



## Basic Operations

- ❑ The printer is exposed to direct sunlight or interference from other ambient light sources.

Shade the printer from sources of interference.

- ❑ 2.5 is selected for **Platen Gap** in the setup menu.

Choose another option for **Platen Gap**. Auto Head Alignment may not be available when 2.0 is selected for **Platen Gap** in the setup menu. If auto gap adjustment is not available, perform gap adjustment manually.

- ❑ Nozzles are clogged.

Perform head cleaning to remove any clogs.

- ❑ Pull the media to the prescribed position before performing Head Alignment. Correct adjustment may not be possible if the media is not pulled sufficiently because the condition of the leading edge of the media may worsen due to waves or other issues.

Loading Media  "Loading and Exchanging Media" on page 32

### Setting procedure

This section details the steps involved in auto Bi-d alignment.

- 1 Confirm that the media has been pulled to the prescribed position.

Correct adjustment may not be possible if the media is not pulled sufficiently.

Loading Media  "Loading and Exchanging Media" on page 32

- 2 Use the ▼/▲ buttons to select **Head Alignment** and press the OK button.

- 3 Use the ▼/▲ buttons to select **Auto(Bi-D)** and press the OK button.

- 4 Press the OK button to print a test pattern and perform auto head alignment.

## Heating & Drying

Set the temperature of the heaters or turn the fan for the additional print drying system (supplied with the SC-S50600 series; optional with other models) on or off.

### Note:

Adjust heater temperature as follows:

- ❑ Set the heaters to the temperatures recommended in the documentation provided with the media, if available.
- ❑ Raise the temperature if the print results are blurred or smudged or the ink clots. Note, however, that raising the temperature too high can cause the media to shrink, wrinkle, or deteriorate.

This section details the steps involved in setting the temperature for the heaters.

- 1 Use the ▼/▲ buttons to select **Heating & Drying** and press the OK button.

- 2 Select **Heater Temperature** and press the OK button.

- 3 The temperatures for the pre-, platen, and after heaters can each be adjusted separately.

Use the ►/◀ buttons to select a heater. From left, the options are pre-heater, platen heater, and after heater.

After selecting the desired heater, use the ▼/▲ buttons to choose the temperature.

- 4 Select the desired option and press the OK button.

- 5 Press the ⏪ button twice to return to the customize settings menu.

## Media Suction

While printing, the printer uses suction to maintain the correct distance between the media and the printer head; the amount varies with the type of media. Less suction is used for thin media that would not print or feed correctly at high levels of suction.

- 1 Use the ▼/▲ buttons to select **Media Suction** and press the OK button.

## Basic Operations

- 2 Use the ▼/▲ buttons to choose a value.
- 3 Select the desired option and press the OK button.
- 4 Press the ⏪ button to return to the customize settings menu.

### Head Movement

Choose the range in which the print head moves during printing.

- 1 Use the ▼/▲ buttons to select **Head Movement** and press the OK button.
- 2 Use the ▼/▲ buttons to select the desired setting and press the OK button.

For faster printing, select **Data Width**.

For even, high-quality printing, select **Printer Full Width**.

### Multi-Strike Printing

Choose the number of times each line is printed.

- 1 Use the ▼/▲ buttons to select **Multi-Strike Printing** and press the OK button.
- 2 Use the ▼/▲ buttons to choose a value.
- 3 Select the desired option and press the OK button.
- 4 Press the ⏪ button to return to the customize settings menu.

### Roll Type

Choose **Printable Side Out** or **Printable Side In** according to how the media is rolled.

- 1 Use the ▼/▲ buttons to select **Roll Type** and press the OK button.
- 2 Use the ▼/▲ buttons to select the desired setting and press the OK button.

- 3 Select the desired option and press the OK button.

### Tension Measurement

**Periodically** is recommended in most circumstances. Choose **Off** if slack develops in the media or other printing problems occur.

- 1 Use the ▼/▲ buttons to select **Tension Measurement** and press the OK button.
- 2 Use the ▼/▲ buttons to select the desired setting and press the OK button.
- 3 Select the desired option and press the OK button.

### Media Tension

Increase tension if creases appear in the media during printing. The higher the value, the greater the tension.

If you have previously performed Feed Adjustment, you will need to perform it again after adjusting Media Tension.

 [“Feed Adjustment” on page 71](#)

- 1 Use the ▼/▲ buttons to select **Media Tension** and press the OK button.
- 2 Use the ▼/▲ buttons to choose a value.
- 3 Select the desired option and press the OK button.
- 4 Press the ⏪ button to return to the customize settings menu.

### Feed Speed

Choose a slower feed speed if media is creased or torn or sticks together during printing. The lower the value, the slower the speed.

- 1 Use the ▼/▲ buttons to select **Feed Speed** and press the OK button.
- 2 Use the ▼/▲ buttons to choose a value.

## Basic Operations

- 3 Select the desired option and press the OK button.
- 4 Press the  button to return to the customize settings menu.

### Exiting the Menus

Press  to exit the menus.

## Changing Heater and Fan Settings

Adjust the temperature of the heaters during printing or turn the fan for the additional print drying system (supplied with the SC-S50600 series; optional with other models) on or off.

The default heater temperatures are as follows.

Pre-heater: 40 °C

Platen heater: 40 °C

After heater: 50 °C

Heater status can be viewed in the control panel.  [“Understanding the Display” on page 20](#)

**Additional Dryer** defaults to **On**; at this setting, the fan turns on automatically when printing starts.

**Additional Dryer** is available only when an additional print drying system (supplied with the SC-S50600 series; optional with other models) is installed.



The following gives the procedure used when the additional print drying system (supplied with SC-S50600 series; optional with other models) is installed.

**Note:**



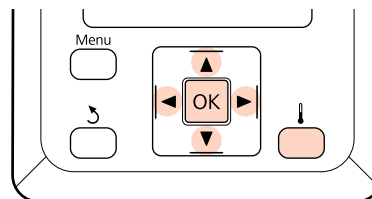

- Temperature and Additional Dryer settings can be stored separately for each media type.  [“Saving Optimal Settings for the Current Media \(Print Media Settings\)” on page 69](#)*
- The time needed for the heaters to reach the specified temperatures varies with the ambient temperature.*

Buttons that are used in the following settings





- 1 After checking that the printer is ready, press the  button to display the Heating & Drying menu.
- 2 Use the / buttons to select the desired option and press the OK button.
- 3 Choose a value.

### Heater Temperature

- (1) The temperatures for the pre-, platen, and after heaters can each be adjusted separately.
- (2) Use the / buttons to select a heater. From left, the options are pre-heater, platen heater, and after heater.
- (3) After selecting the desired heater, use the / buttons to choose the temperature.
- (4) Select the desired option and press the OK button.

### Additional Dryer

- (1) Use the / buttons to select **On** or **Off**.
- (2) Press the OK button.

## Head Alignment (Manual Adjustment)

Head Alignment can be performed automatically or manually.

For more information on automatic adjustment, see  [“Head Alignment” on page 72.](#)

## Basic Operations

In manual adjustment, you need to check the pattern and enter the optimum adjustment value for alignment.

Align the head manually if you feel that auto head alignment has not completely resolved the problem.

In manual adjustment, you can select and run the following two adjustment pattern types.

### Line pattern

Select this pattern in most situations.

### Block pattern

Select if you feel that Line pattern adjustment has not completely resolved the problem.

### Notes on correct adjustment

The condition of media is important for correct head alignment.

Observe the following points when positioning media.

Head Alignment varies with the media used. Load and adjust the media that will be used in the actual print job.

Head alignment is not available under the following conditions:

- The media is transparent or colored.
- The printer is exposed to direct sunlight or interference from other ambient light sources.

Shade the printer from sources of interference.

2.5 is selected for **Platen Gap** in the setup menu.

Choose another option for **Platen Gap**. Auto Head Alignment may not be available when 2.0 is selected for **Platen Gap** in the setup menu. If auto gap adjustment is not available, perform gap adjustment manually.

Nozzles are clogged.

Perform head cleaning to remove any clogs.

Pull the media to the prescribed position before performing Head Alignment. Correct adjustment may not be possible if the media is not pulled sufficiently because the condition of the leading edge of the media may worsen due to waves or other issues.

Loading Media  [“Loading and Exchanging Media” on page 32](#)

Buttons that are used in the following settings

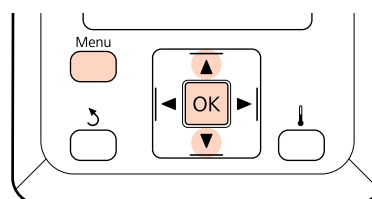

**1** Confirm that the media has been pulled to the prescribed position.

Correct adjustment may not be possible if the media is not pulled sufficiently.

Loading Media  [“Loading and Exchanging Media” on page 32](#)

**2** After confirming that the printer is ready, press the **Menu** button.

The settings menu will be displayed.

**3** Select **Media Setup** and press the OK button.

**4** Use the ▼/▲ buttons to select **Customize Settings** and press the OK button.

**5** Use the ▼/▲ buttons to select a media setting bank number between 1 and 30 and then press the OK button.

Note that any settings already saved in the printer will be overwritten.

**6** Use the ▼/▲ buttons to select **Head Alignment** and press the OK button.

**7** Use the ▼/▲ buttons to select the adjustment method and press the OK button.

## Basic Operations

- 8** Use the ▼/▲ buttons to select **Line pattern** or **Block pattern** and press the OK button.

When **Block pattern** is selected, White (SC-S70600 series, SC-S50600 series only) and Yellow adjustment patterns are not printed.

- 9** The printer will print a test pattern.

- 10** Check the printed adjustment pattern.

### When Line Pattern was selected

In the following example, this would be pattern number 2.

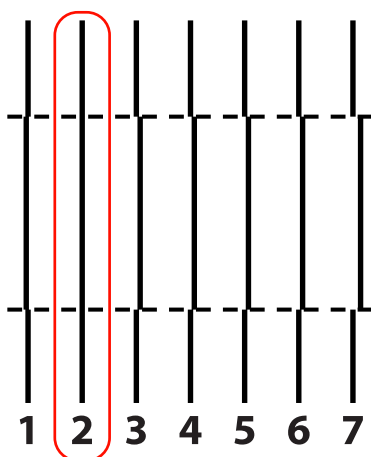

### When Block Pattern was selected

In the following example, this would be pattern number 2.

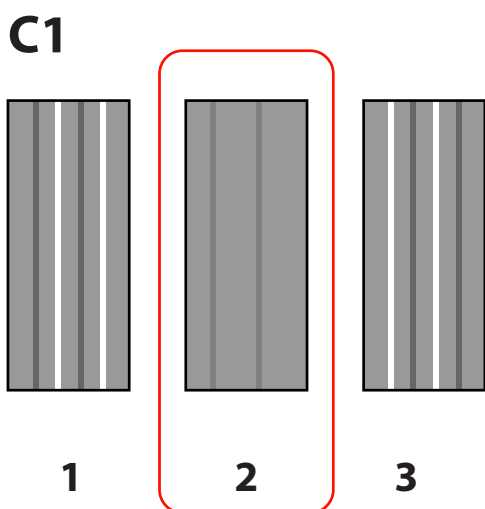

- 11** A screen to enter values will be displayed. Using the ▼/▲ buttons, enter the pattern number recorded in Step 10 and press the OK button.

- 12** When multiple check patterns have been printed, select the number per check pattern, and then press the OK button.

The media setup menu will be displayed when you enter the pattern number for the last color.

## Feed Adjustment (Manual Feed Adjustment)

**Feed Adjustment** is used to correct banding (horizontal banding, lines, or strips of uneven color).

Feed Adjustment can be performed automatically or manually.

For more information on auto feed adjustment, see [☞ “Feed Adjustment” on page 71](#)

Two methods are available:

Adjust the feed manually if you feel that auto feed adjustment has not completely resolved the problem.

- Visually inspect print results and enter a correction by hand.
- Enter a correction during printing and inspect the results.

### Notes on correct adjustment

The condition of media is important for correct feed adjustment.

Observe the following points when loading media.

- Feed adjustment varies with the media being used. Load the media for which feed adjustment is required under the same conditions as the actual print job. For example, if you are using the auto take-up reel unit for printing, the auto take-up reel unit should also be used for feed adjustment.

Furthermore, when installing the heavy roll media system, the media must be loaded and feed adjustment performed again, even if once you adjust with the standard roll media system.

- Feed adjustment is not available under the following conditions:
  - The media is transparent or colored.

## Basic Operations

- ❑ The printer is exposed to direct sunlight or interference from other ambient light sources.

Shade the printer from sources of interference.

- ❑ 2.5 is selected for **Platen Gap** in the setup menu.

Choose another option for **Platen Gap**.

- ❑ Nozzles are clogged.

Perform head cleaning to remove any clogs.

- ❑ Pull the media to the prescribed position before performing Feed Adjustment. Correct adjustment may not be possible if the media is not pulled sufficiently because the condition of the leading edge of the media may worsen due to waves or other issues.

Loading Media  “Loading and Exchanging Media” on page 32

- ❑ Do not perform feed adjustment on sections of media that have been fed and then rewound when using the SC-S70600 series or SC-S50600 series. Media that has been fed and then rewound may have traces or other issues from rollers and it may not be possible to adjust correctly.

## Using a Test Pattern

Buttons that are used in the following settings

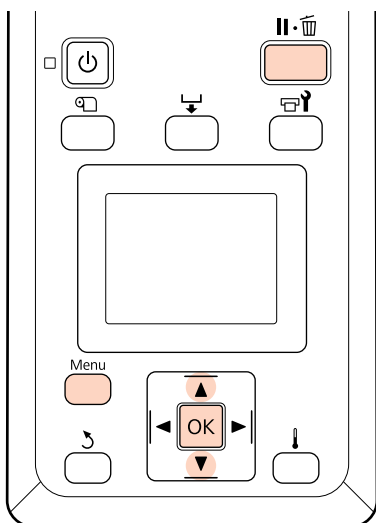

- 1 Confirm that the media has been pulled to the prescribed position.

Correct adjustment may not be possible if the media is not pulled sufficiently.

Loading Media  “Loading and Exchanging Media” on page 32

- 2 After confirming that the printer is ready, press the **Menu** button.

The settings menu will be displayed.

- 3 Select **Media Setup** and press the OK button.

- 4 Use the ▼/▲ buttons to select **Customize Settings** and press the OK button.

- 5 Use the ▼/▲ buttons to select a media setting bank number between 1 and 30 and then press the OK button.

Note that any settings already saved in the printer will be overwritten.

- 6 Use the ▼/▲ buttons to select **Feed Adjustment** and press the OK button.

- 7 Select **Manual** and press the OK button.

- 8 Use the ▼/▲ buttons to select a test pattern and press the OK button twice.

The longer the pattern, the more accurate the adjustment.

- 9 The printer will print a test pattern.

### Basic Operations

- 10** Measure the distance between the center “+” symbols.

Use a value measured at the center only.

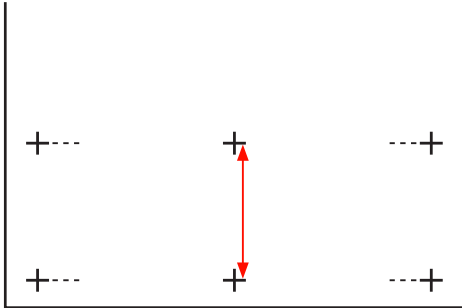

- 11** Pattern length is displayed in the control panel. Using the ▼/▲ buttons, enter the value recorded in Step 10 and press the OK button.

If, in contrast, the feed amount is too large, white bands (pale stripes) will appear; adjust the feed amount downwards.

- 3** If you are not satisfied with the results, use the ▼/▲ buttons to enter an adjustment value.
- 4** Press the OK button when settings are complete.
- Once the feed amount has been adjusted, printing will continue at the new value.

**Note:**

The new value is erased when:

- The media loading lever is raised
- The printer is turned off
- Changes are made to **Feed Adjustment** in the **Media Setup** menu.

## Performing Feed Adjustment During Printing

Buttons that are used in the following settings

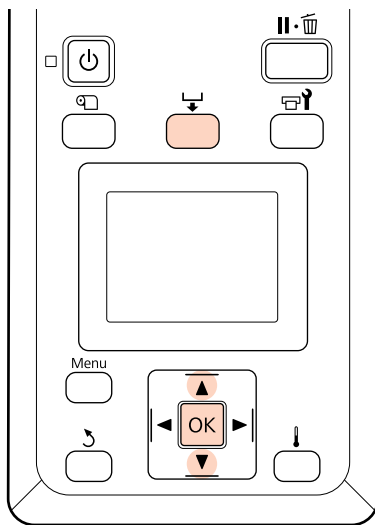

- 1** Press the  button during printing.
- 2** An adjustment value will be displayed.//Use the ▼/▲ buttons to select a value.

If the feed amount is too small, black bands (dark stripes) will appear; adjust the feed amount upwards.

Basic Operations

# Printable area

## SC-S70600 series/SC-S50600 series

The printable area depends on whether low or high pressure rollers are used to set the media.

### When using low pressure rollers (normal printing)

The gray area in the illustration below shows the printable area. The arrow indicates the feed direction. **A** indicates the pressure rollers on both edges when the pressure rollers have been set correctly on the media. **1** **2** positions vary with the option selected for **Media Size Check**, as shown below.

**1** (Right edge of media)

**On** selected for **Media Size Check**: The right edge of the media.

**Off** selected for **Media Size Check**: 5 mm outwards from **A** on the right.

**2** (Left edge of media)

**On** selected for **Media Size Check**: The left edge of the media.

**Off** selected for **Media Size Check**: 5 mm outwards from **A** on the left.

**On selected for Media Size Check**

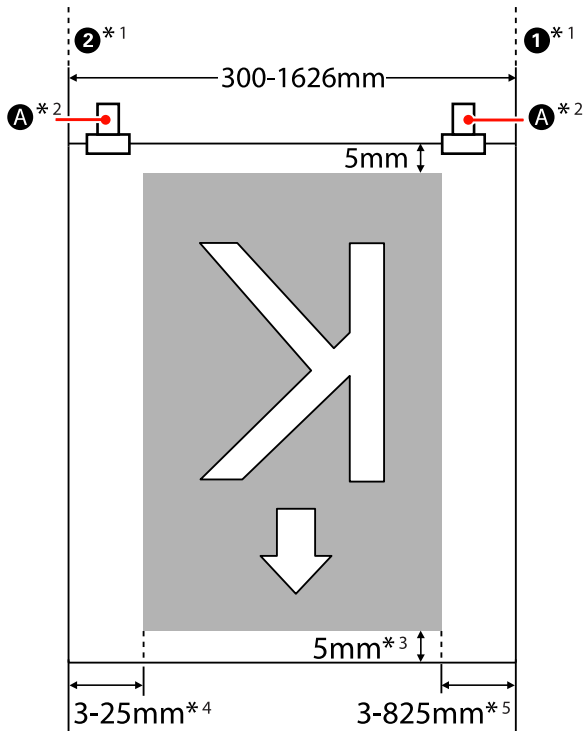

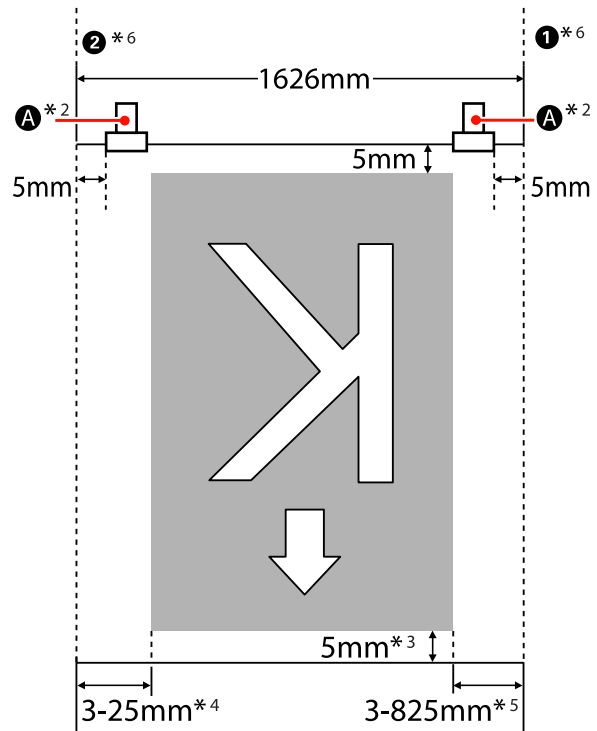

**Off selected for Media Size Check**





## Basic Operations

- \*1 When media holding plates are attached, within 5mm of the left and right edges of the media is recognized as the media edge.  
For example, if the Side Margin is set to 5mm, the actual margin is 10mm. Note that if the media holding plates are attached incorrectly, this value fluctuates.  
 [“When the Standard Media Feeding Unit Is Installed” on page 36](#)  
 [“Using the Optional Heavy Roll Media Feeding Unit” on page 42](#)
- \*2 When printing continuously for an extended length, there is a strong tendency for the media to skew during printing. Therefore, we recommend setting **A** within 5 mm of the edges of the media.
- \*3 The value when jobs are printed continuously. Differs by the length the media was pulled when the media is loaded.
- \*4 The value selected for **Side Margin(Left)** in the setup menu. The default value is 5 mm.
- \*5 The total of the values selected for **Print Start Position** and **Side Margin(Right)** in the setup menu. The default settings for **Print Start Position** and **Side Margin(Right)** are 0 mm and 5 mm.
- \*6 Leave left and right margins of 10 mm or more when using media holding plates. Narrower margins could result in printer printing over the plates.

**Note:**

- When side margins are configured on both the printer and RIP, this becomes the combined value.
- If the total of the print data width and side margin exceeds the printable area, a portion of the data will not be printed.
- When **Media Size Check** is **OFF** and the pressure rollers are not positioned correctly, printing may occur outside the left and right edges of the media. Ink used outside the edges of the media will stain the inside of the printer.  
 [“Loading Media \(SC-S70600 series, SC-S50600 series\)” on page 36](#)

## Basic Operations

### When using high pressure rollers (when using transparent film or for ink layering)

The printable area is the area excluding the margins configured from the positioning of pressure rollers. (See the gray area in the illustration below.) The arrow indicates the feed direction. **A** indicates the position of the high pressure rollers.

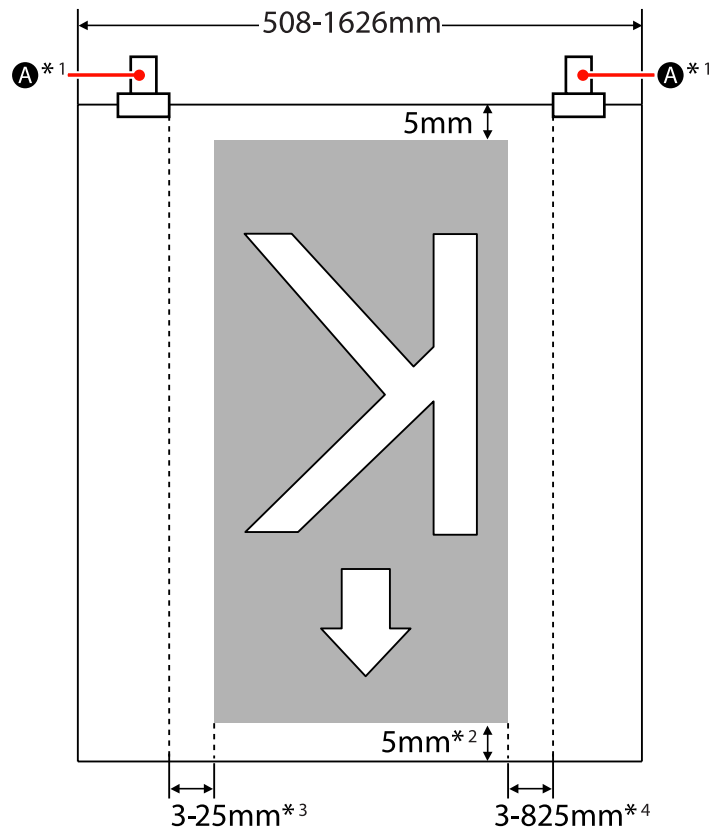

- \*1 When printing continuously for an extended length, there is a strong tendency for the media to move diagonally during printing. Therefore, we recommend setting **A** within 10 mm of the edges of the media.
- \*2 The value when jobs are printed continuously. Differs by the length the media was pulled when the media is loaded.
- \*3 The value selected for **Side Margin(Left)** in the setup menu. The default value is 5 mm.
- \*4 The total of the values selected for **Print Start Position** and **Side Margin(Right)** in the setup menu. The default settings for **Print Start Position** and **Side Margin(Right)** are 0 mm and 5 mm.

**Note:**

- When side margins are configured on both the printer and RIP, this becomes the combined value.
- If the total of the print data width and side margin exceeds the printable area, a portion of the data will not be printed.

## SC-S30600 series

The gray area in the illustration below shows the printable area. The arrow indicates the feed direction.

### Basic Operations

① ② positions vary with the option selected for **Media Size Check**, as shown below.

① (Right edge of media)

**On** selected for **Media Size Check**: The right edge of the media.

**Off** selected for **Media Size Check**: Right edge reference position \*1

② (Left edge of media)

**On** selected for **Media Size Check**: The left edge of the media.

**Off** selected for **Media Size Check**: 1626 mm (64 inches) to the left from the right edge reference position

**On selected for Media Size Check**

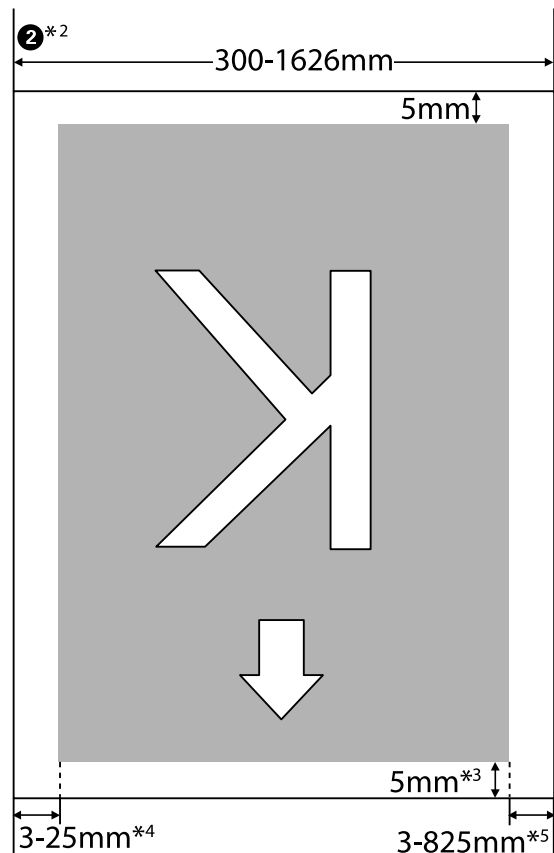

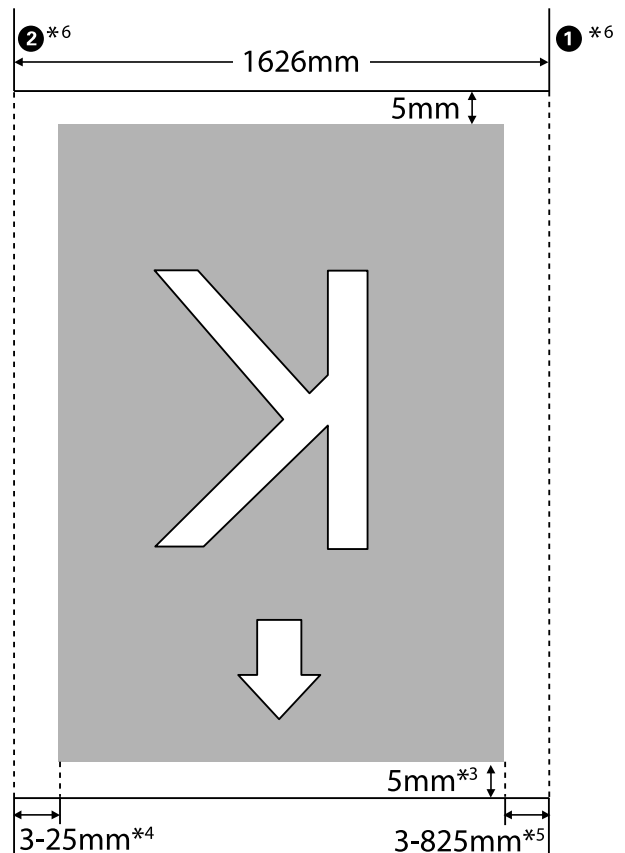

**Off selected for Media Size Check**

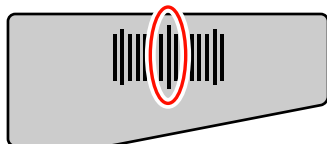

\*1 The guide for the right edge reference position is the longest mark of the label on the after heater.



## Basic Operations

- \*2 When media holding plates are attached, within 5mm of the left and right edges of the media is recognized as the media edge.  
For example, if the Side Margin is set to 5mm, the actual margin is 10mm. Note that if the media holding plates are attached incorrectly, this value fluctuates.  
 [“When the Standard Media Feeding Unit Is Installed” on page 48](#)  
 [“Using the Optional Heavy Roll Media Feeding Unit” on page 53](#)
- \*3 The value when jobs are printed continuously. Differs by the length the media was pulled when the media is set.
- \*4 The value selected for **Side Margin(Left)** in the setup menu. The default value is 5 mm.
- \*5 The total of the values selected for **Print Start Position** and **Side Margin(Right)** in the setup menu. The default settings for **Print Start Position** and **Side Margin(Right)** are 0 mm and 5 mm.
- \*6 Leave left and right margins of 10 mm or more when using media holding plates. Narrower margins could result in printer printing over the plates.

### Note:

- When side margins are configured on both the printer and RIP, this becomes the combined value.
  - If the total of the print data width and side margin exceeds the printable area, a portion of the data will not be printed.
  - If the following points are not observed when **Media Size Check** is **OFF**, printing may occur outside the left and right edges of the media. Ink used outside the edges of the media will stain the inside of the printer.
    - Ensure that the print data width does not exceed the loaded media width.
    - When media is loaded to the left of the right side reference position, align the **Print Start Position** setting with the position where the media set.
-  [“Printer Setup Menu” on page 124](#)

Maintenance

# Maintenance

## Maintenance types and frequency

It is necessary to perform proper maintenance at appropriate frequency to maintain print quality. Failure to perform appropriate maintenance will shorten product life. Read this section and perform maintenance appropriately.

This document comes with a check sheet so that you can tell at a glance when maintenance was last performed. Print the check sheet to help schedule maintenance.

 [“Regular Cleaning Check Sheet” on page 99](#)

 [“Consumable Replacement Check Sheet” on page 107](#)



## Regular Cleaning

Clean the printer at the frequency listed the chart below. If cleaning is neglected, and the printer is used with ink stains, lint, and dust attached, the following trouble may occur.



- Ink drops from lint or dust on the nozzle surface of the print head.



- Clogged nozzles during printing.
- Nozzle clogs cannot be cleared even after repeated head cleaning.
- Print head damage.





Component to be cleaned	Frequency
Around the Print Head	We recommend cleaning at the end of each workday.
Around caps (Wiper, caps, wiper cleaner, wiper rail)	If the printer is left unused, the ink will congeal and be more difficult to remove.  <a href="#">“Cleaning Around the Print Head” on page 90</a>  <a href="#">“Cleaning Around Caps” on page 91</a>

## Maintenance

Component to be cleaned	Frequency
Inside (Platen heater, pressure rollers, media holding plates, and left-side maintenance cover interior)	We recommend that you clean these areas from once a week to once a month.  <a href="#">"Cleaning Inside the Printer" on page 96</a>
Flushing pad	When ink stains, lint, and dust are present.  <a href="#">"Cleaning the Flushing Pad" on page 98</a>

## Replacing Consumables

Replace consumables at the frequency listed below.







Name	Frequency
Ink cartridges	When a replacement message is displayed on the control panel screen.  <a href="#">"Replacement and Shake of Ink Cartridges" on page 101</a>
Waste ink bottle	When a replacement message is displayed on the control panel screen.  <a href="#">"Disposing of Waste Ink" on page 102</a>
Wiper cleaner	<input type="checkbox"/> Once every six months <input type="checkbox"/> When ink stains the absorbant section. <input type="checkbox"/> At wiper replacement.  <a href="#">"Replacing the Wiper and Wiper Cleaner" on page 104</a>
Wiper	<input type="checkbox"/> Once every six months <input type="checkbox"/> When the wiper section is worn or deteriorated. <input type="checkbox"/> At wiper cleaner replacement.  <a href="#">"Replacing the Wiper and Wiper Cleaner" on page 104</a>
Flushing pad	<input type="checkbox"/> Once every six months <input type="checkbox"/> When lint and dust are stuck to the surface. <input type="checkbox"/> When ink stains appear on the media  <a href="#">"Replacing the Flushing Pad" on page 105</a>

## Other maintenance

Perform the following maintenance when necessary.

An asterisk (\*) indicates maintenance to be performed only when using spot color inks with the SC-S70600 series or SC-S50600 series.

## Maintenance

Type	Frequency
Shaking ink cartridges	<p>The frequency depends on the ink color, as shown below.</p> <ul style="list-style-type: none"> <li><input type="checkbox"/> Spot color Inks: Once every 24 hours, or when the following message appears on the control panel screen. <b>Remove and shake WH/MS ink cartridges.</b> <b>Remove and shake WH ink cartridge(s).</b></li> <li><input type="checkbox"/> Other: Once every 3 weeks. (No message is displayed.)</li> </ul> <p>Shaking ink cartridges  <a href="#">"Replacement and Shake of Ink Cartridges" on page 101</a></p>
Checking for clogged nozzles	<p>When checking for clogged nozzles.</p> <p> <a href="#">"Checking for clogged nozzles" on page 109</a></p>
Head Cleaning	<p>When a clog is found after checking for clogged nozzles.</p> <p> <a href="#">"Head Cleaning" on page 110</a></p>
Ink Circulation*	<p>When you notice uneven colors (areas of uneven density) in print results for spot color inks.</p> <p> <a href="#">"Ink Circulation and Ink Refresh" on page 111</a></p>
Ink refresh*	<p>When you notice uneven colors in print results for spot color inks once the printer is turned on following a period of disuse.</p> <p> <a href="#">"Ink Circulation and Ink Refresh" on page 111</a></p>
Pre-Storage Maintenance (Pre-Storage Maint. performed)	<p>When the printer will not be used for an extended period (and switched off.)</p> <p>The storage period guideline varies with the model of printer used.</p> <ul style="list-style-type: none"> <li><input type="checkbox"/> SC-S70600 series(10 color mode), SC-S50600 series (5 color mode): 7 days or more</li> <li><input type="checkbox"/> SC-S70600 series (8 color mode): 2 weeks or more</li> <li><input type="checkbox"/> SC-S50600 series (4 color mode): 3 weeks or more</li> <li><input type="checkbox"/> SC-S30600 series: 1 month or more</li> </ul> <p>See the following for more information.</p> <p> <a href="#">"Long-term Storage (Pre-storage Maintenance)" on page 112</a></p>

## Maintenance

# Preparation and Notes

## What You'll Need

Ready the following items before beginning cleaning and replacement.

- Protective eyewear (available in the market)

Protects your eyes from ink and ink cleaner.

- A maintenance kit (supplied with printer)

The following items are in the kit.

- Gloves
- Cleaning wiper
- Cleaning stick
- Wiper
- Wiper cleaner
- Flushing pad
- Clean room wiper
- Tweezers

When the maintenance kit included with the printer has been completely used, purchase consumables.

[🔗 “Options and Consumable Products” on page 145](#)

- Ink cleaner (consumable)

Use when wiping ink stains.

Usage method [🔗 “Using Ink Cleaner” on page 89](#)

[🔗 “Options and Consumable Products” on page 145](#)

- A metal tray (supplied with printer)

Used cleaning sticks and wiper, wiper cleaner, and flushing pads taken from the printer can be placed here.



### **Important:**

*If placed on the printer, used cleaning sticks and other cleaning materials may leave stains that, owing to the characteristics of the ink, may be difficult to remove.*

- Soft cloth, brush (available in the market)

Use when cleaning inside the printer. We recommend an item that is not likely to generate lint or static electricity.

## Notes on Cleaning

- Remove the media from the printer before proceeding.
- Complete the task within 10 minutes to prevent the print head drying out. A buzzer will sound after 10 minutes.
- Never touch the belts, circuit boards, or any parts that do not require cleaning. Failure to observe this precaution could result in malfunction or reduced print quality.
- Use only the supplied cleaning sticks or sticks contained in a maintenance kit. Other types of sticks that produce lint will damage the print head.
- Always use fresh cleaning sticks. Re-using sticks can make stains even harder to remove.
- Do not touch the tips of the sticks. Oil from your hands could damage the print head.
- Do not get alcohol or water on the caps or the nozzle surface. Ink congeals when mixed with water or alcohol.
- Touch a metallic object before starting work to discharge any static electricity.



## Maintenance

### Moving the Print Head

This section describes how to position the print head for part cleaning.

#### **!** Important:

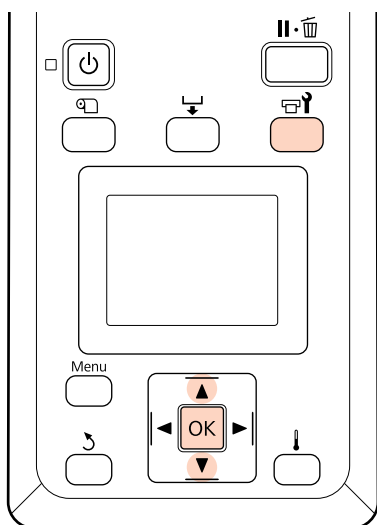

Be sure to follow the steps below when positioning the print head. Moving the print head manually could cause malfunction.

Buttons that are used in the following settings



- 1 Confirm that the printer is on and press .

The Maintenance menu will be displayed.

- 2 Use the / buttons to select **Head Maintenance** and press the OK button.

The print head moves to the cleaning position.

### Using Ink Cleaner

Use ink cleaner to clean around the print head, around the caps, and the flushing pad only. Using ink cleaner on other parts of the printer could damage the product.

#### **!** Caution:

- ❑ Store ink cleaner in a location out of reach of children.
- ❑ Wear protective eyewear and gloves when handling Ink Cleaner.  
*Should waste ink contact your skin or enter your eyes or mouth, immediately take the following actions:*
- ❑ If fluid adheres to your skin, immediately wash it off using large volumes of soapy water. Consult a physician if the skin appears irritated or is discolored.
- ❑ If fluid enters your eyes, rinse immediately with water. Failure to observe this precaution could result in bloodshot eyes or mild inflammation.
- ❑ If fluid is swallowed, consult a physician immediately; do not induce vomiting.
- ❑ After handling Ink Cleaner, wash your hands and gargle thoroughly.

- 1 Pour about 10 ml of ink cleaner into the cup supplied with the ink cleaner.

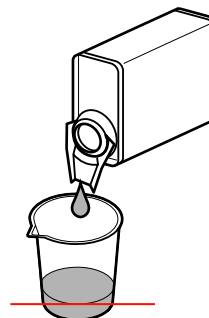

- 2 Dampen the cleaning stick with ink cleaner.

Do not allow ink cleaner to drip from the cleaning stick.

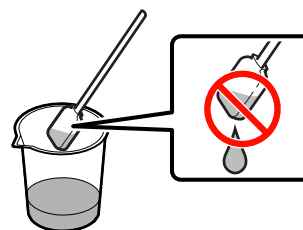

When dampening a clean-room wiper with ink cleaner, use ink cleaner poured into a container.

Maintenance

**! Important:**

- ❑ Do not reuse ink cleaner. Using dirty ink cleaner will make staining worse.
- ❑ Used ink cleaner is classified as industrial waste and should be disposed of in the same way as used ink.
- ❑ Store ink cleaner at room temperature out of direct sunlight.

**! Important:**

Do not use water or alcohol in place of ink cleaner. Ink congeals when mixed with water or alcohol.

## Regular Cleaning

### Cleaning Around the Print Head

Inspect the area around the print head and remove any ink stains as described below. SC-S70600 series, and SC-S50600 series have 2 print heads. Clean both.

- 1 Position the print head for maintenance and open the left maintenance cover.

 "Moving the Print Head" on page 89

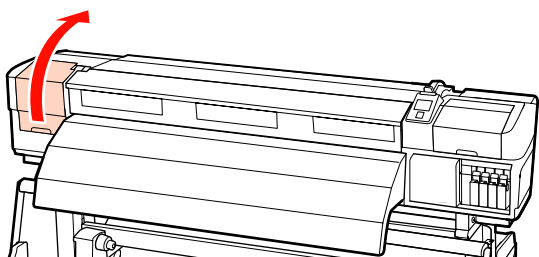

- 2 Dampen a new cleaning stick with the ink cleaner, and then wipe away the dust and dirt of the cleaning wiper.

 "Using Ink Cleaner" on page 89

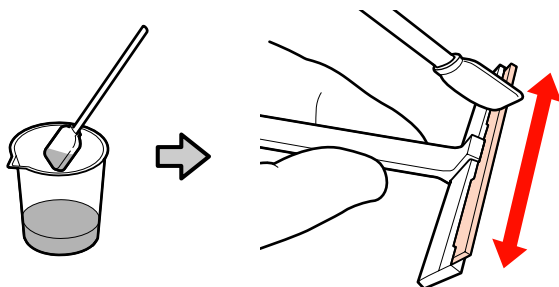

- 3 Perform 1 and 2 with the cleaning stick of Step 2. There are 2 print heads depending on the printer model.

**! Important:**

Observe the following points when wiping to avoid damaging the print head.

- ❑ Dampen the cleaning stick with ink cleaner.
- ❑ Do not touch the nozzles (  section in illustration) with the cleaning stick.
- ❑ The parts indicated below are sensors. Take care not to touch them. Failure to observe this precaution could affect print quality.

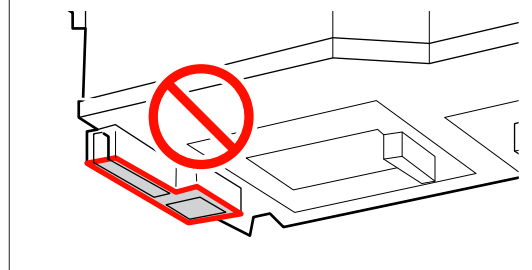

1 Nozzle area:

Dissolve adhered ink stains to make it easier to wipe with a cleaning wiper. Use the cleaning stick perpendicularly as shown in the illustration when dissolving ink between nozzles.

2 Other areas:

Wipe adhered ink, lint, and dust. When lint or dust is caught, hook it with the tip of a cleaning stick.

**Maintenance**

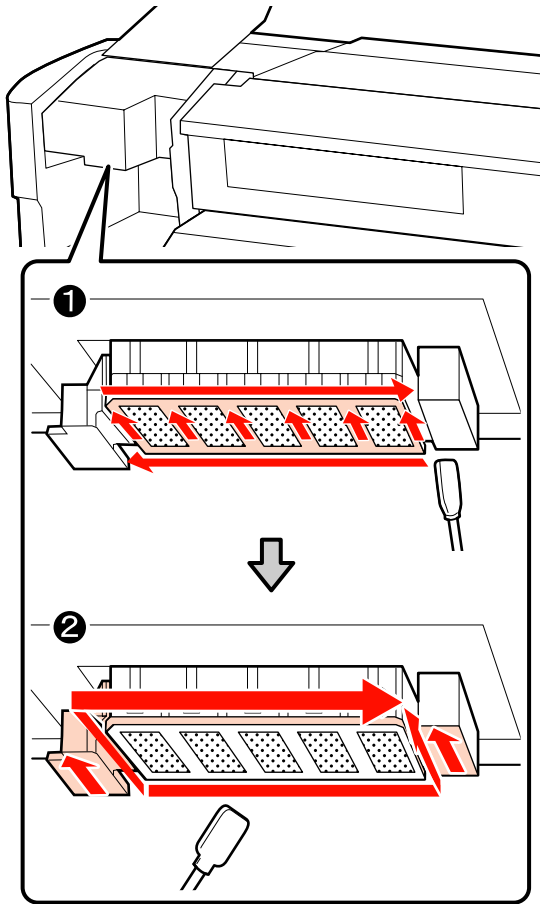

**4** Repeat Steps 1 and 2 until there is no ink, lint, or dust adhered to the print head surface.

(1) Wipe away ink stains and so on from the print head surface by moving the cleaning wiper from the inside toward you once.

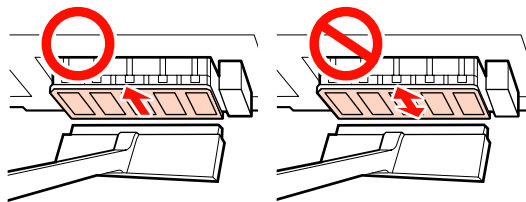

**! Important:**  
Moving the cleaning wiper back and forth could damage the print head.

(2) Use a clean room wiper that was dampened in ink cleaner to wipe the cleaning wiper and remove adhered ink, lint and dust well.

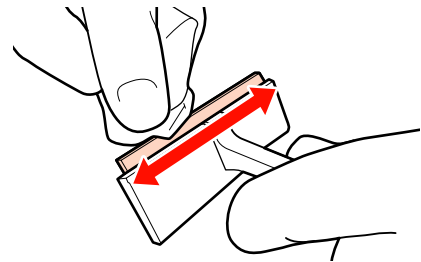

**5** Cleaning of the print head area is complete after adhered ink, lint, and dust have been removed.

**Before cleaning**

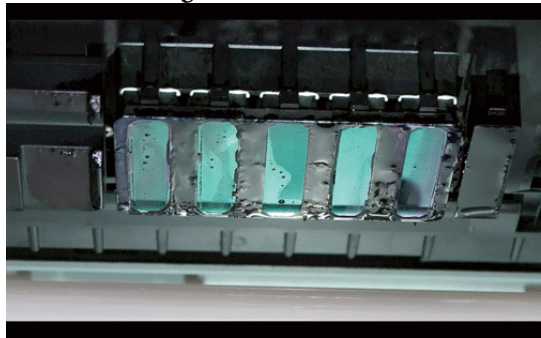

**After cleaning**

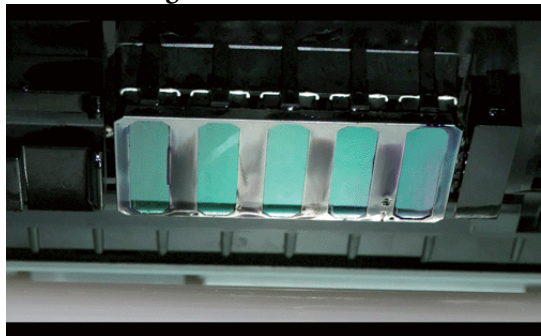

Store used cleaning wipers in a location away from direct sunlight.

**6** Close the left maintenance cover.  
Next, clean around the caps.

**Cleaning Around Caps**

Use the following procedure to clean each part.

(1) Wiper and Caps

## Maintenance

### (2) Wiper cleaner and wiper rail

The following chart shows the number of cleaning areas by printer model.

	SC-S70600 series SC-S50600 series	SC-S30600 series
Wiper	2	1
Cap	10	4
Wiper cleaner	2	1
Wiper rail	2 locations	1 location

### Cleaning Wiper and Caps

- 1 Open the right maintenance cover.

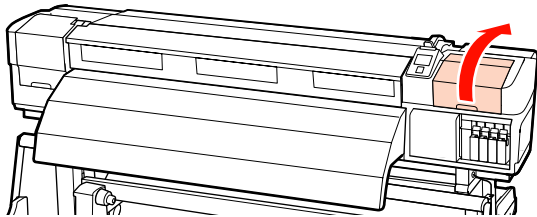

- 2 Dampen a new cleaning stick with ink cleaner.

[“Using Ink Cleaner” on page 89](#)

- 3 Clean the front and back of the wiper with a cleaning stick.

If the attachment points do not require cleaning, clean the wiper as shown below and proceed to Step 9.

If there is ink around the attachment points, remove the wiper for cleaning. Proceed to Step 4.

When the wiper section is worn or deteriorated, we recommend replacing it with a new one.

[“Replacing the Wiper and Wiper Cleaner” on page 104](#)

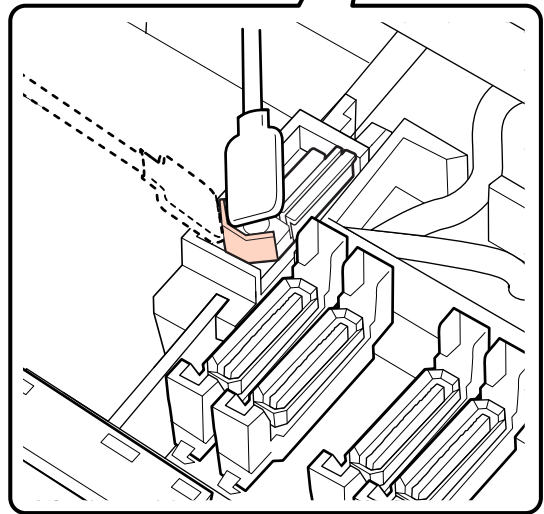
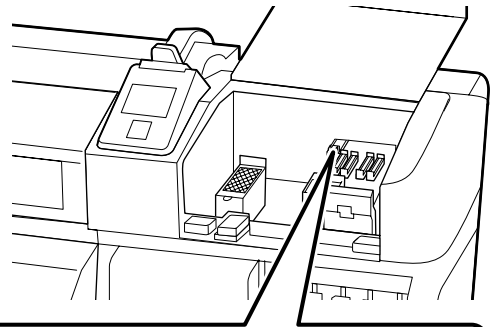

- 4 Remove the wiper.

Holding the wiper by the attachment point, tilt it left and lift it out.

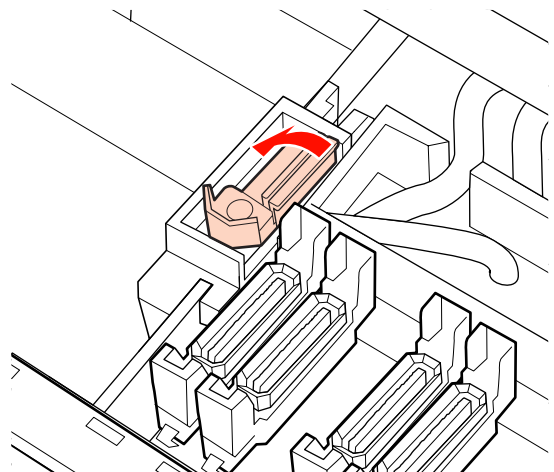

**Maintenance**

- 5** Clean the front and back of the wiper with a cleaning stick.

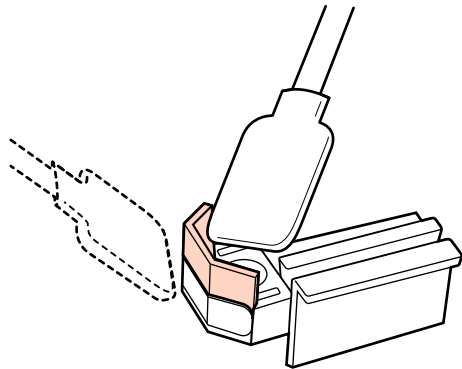

When adhered ink, lint, and dust cannot be wiped away with a cleaning stick, push both sides of the wiper section against a clean room wiper that has been dampened in ink cleaner, and then wipe.

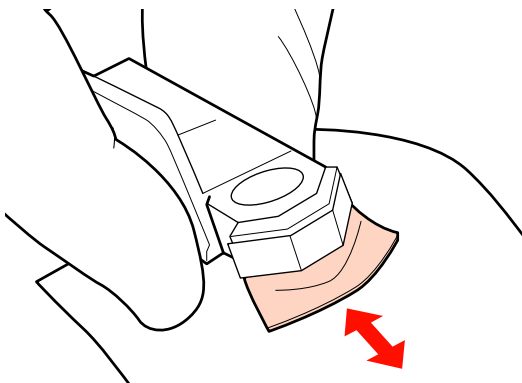

- 6** Clean the bottom of the wiper with a cleaning stick.

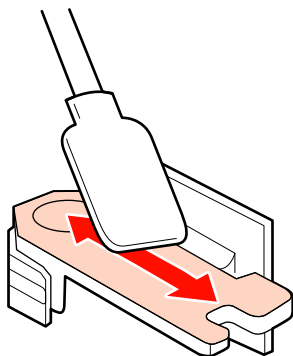

- 7** Clean the attachment points with a cleaning stick.

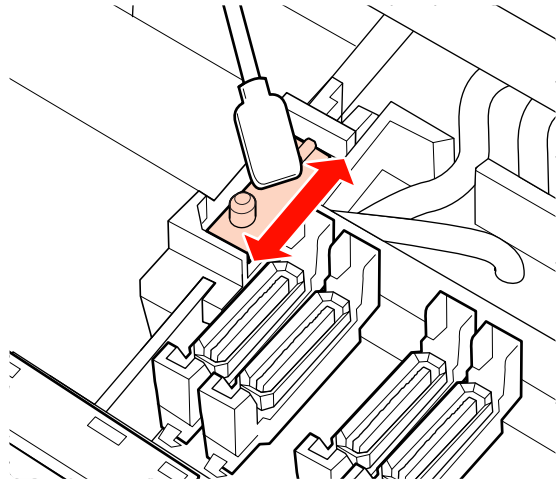

- 8** Return the wiper when cleaning is complete.

Place the attachment point and press down until you hear a click.

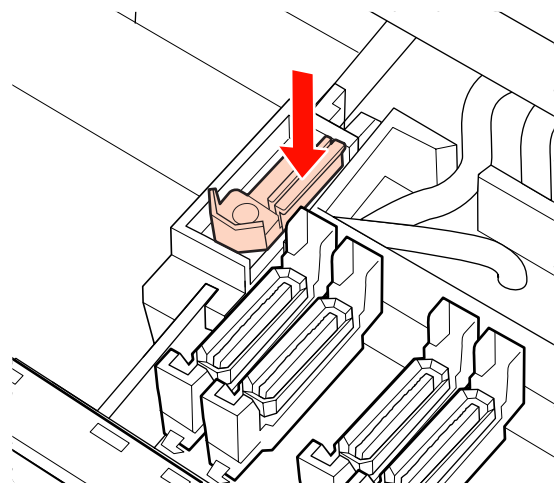

If the remaining wiper for the SC-S70600 series or SC-S50600 series is stained, repeat the process from Step 2.

- 9** Perform Steps 1 through 4 and clean ink, lint, and dust adhered to the caps.

**! Important:**  
Do not push strongly against the edges or surrounding area of the cap with a cleaning stick or touch the inner side of the cap with tweezers. The part maybe deformed, and it may no longer be possible to perform capping correctly.

## Maintenance

- (1) Hold the cleaning stick flat and wipe edges of the cap.

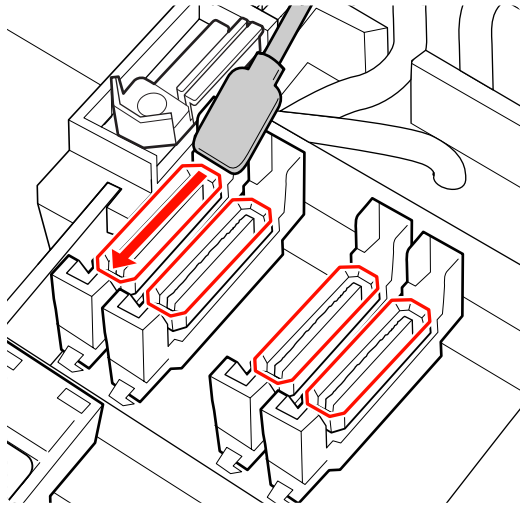

- (2) Hold the cleaning stick perpendicularly and wipe the outer area of the caps.

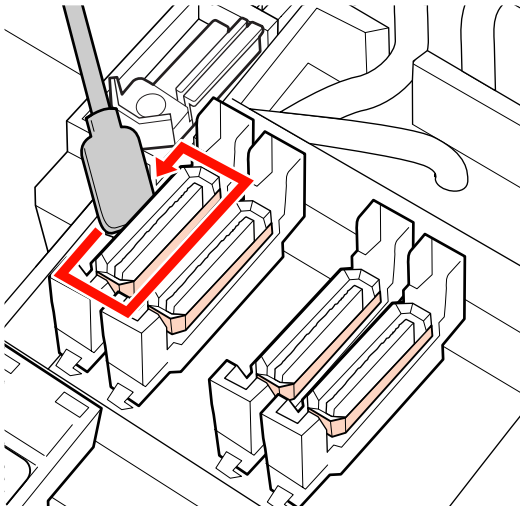

- (3) Hold the cleaning stick perpendicularly to wipe when ink is adhered to the sections in the illustration (inside the inner and front sections).

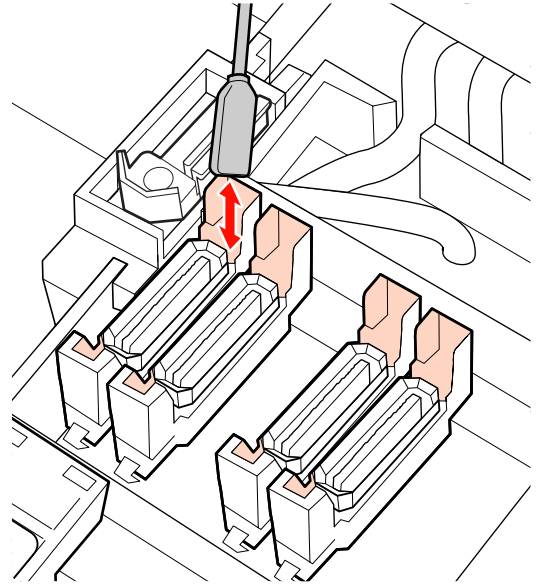

- (4) When lint or dust has adhered to the inside of the cap, remove it using the tip of a cleaning stick or tweezers.

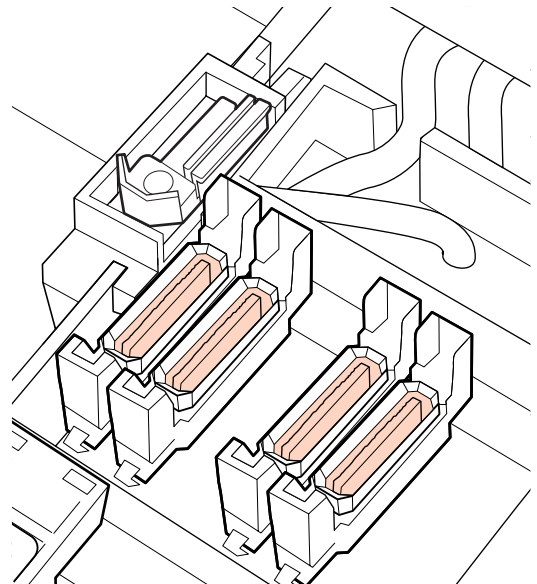

- 10** Press OK in the control panel and confirm that the wiper has moved to the back.

Next, clean the wiper cleaners and wiper rails.

**Maintenance**

**Cleaning the Wiper Cleaner and Wiper Rail**

- 1** Remove the wiper cleaner.  
Grasp the cleaner as shown and lift it from the printer.

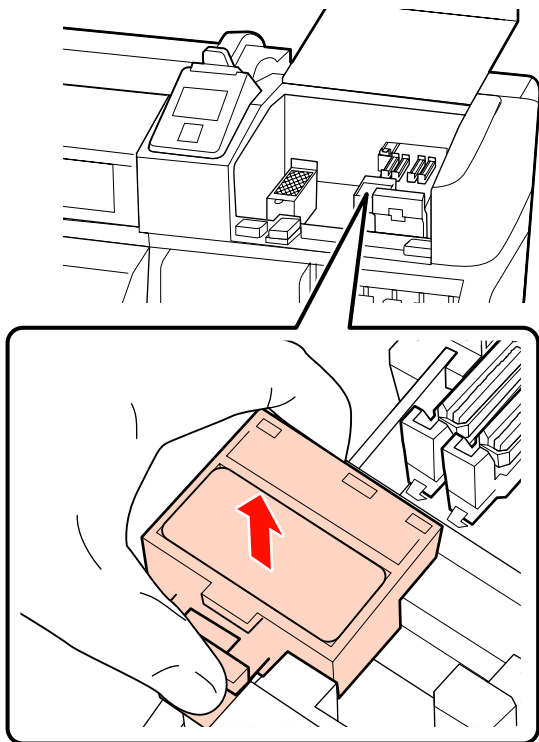

- 2** Dampen a new cleaning stick with ink cleaner.  
[“Using Ink Cleaner” on page 89](#)

- 3** Remove lint or dust adhered to the rear surface of the wiper cleaner using the tip of a cleaning stick.

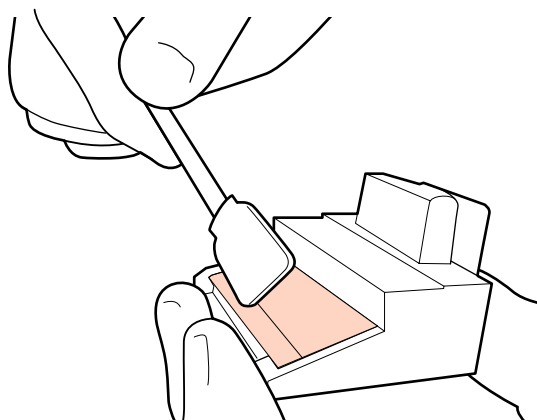

If the ink has solidified and cannot be removed, we recommend exchanging the wiper cleaner with a new one.

[“Replacing the Wiper and Wiper Cleaner” on page 104](#)

- 4** Wipe ink adhered to the wiper rail.

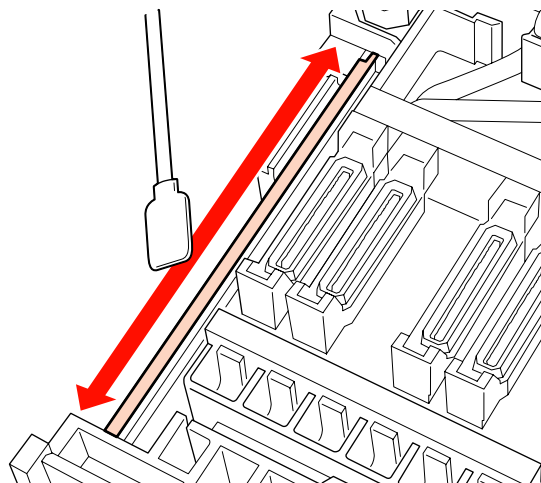

Use the cleaning stick perpendicularly to clean in the gap when ink is adhered to the side surface of the rail as well.

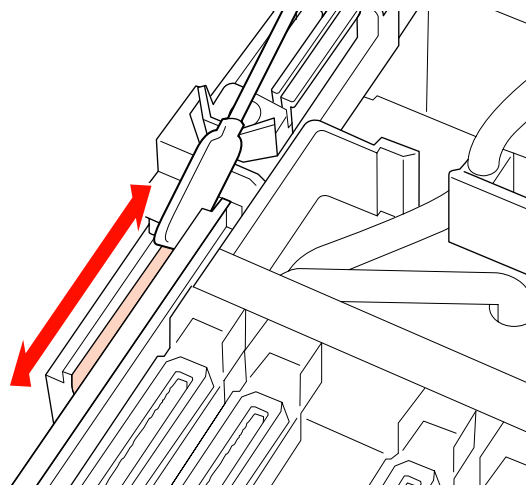

- 5** Attach the wiper cleaner.  
Place on the attachment point and press down until you hear a click.

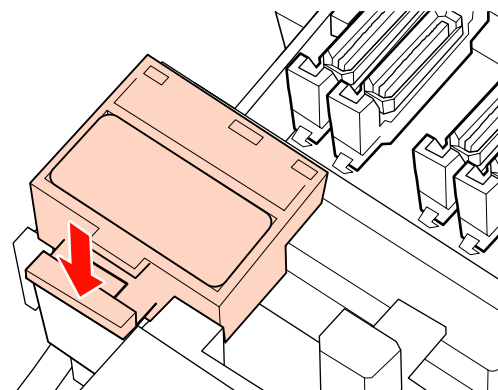

## Maintenance

On the SC-S70600 series and SC-S50600 series, clean the other wiper cleaner and wiper rail in the same manner.

- 6** After cleaning, close the right maintenance cover and press the OK button.

The menus will close when the print head returns to its normal position.

## Cleaning Inside the Printer

Lint, dust, and ink accumulate on the platen heater, pressure rollers, and media holding plates. Ink on these surfaces may be transferred to the media. Furthermore, if lint or dust is left accumulated inside the left maintenance cover, it may adhere around the print head.



**Caution:**

- ❑ The heaters and media holding plate may be hot; observe all necessary precautions. Failure to observe the necessary precautions could result in burns.
- ❑ Be careful not to trap your hands or fingers when opening or closing the front cover. Failure to observe this precaution could result in injury.



**Important:**

When cleaning inside the printer, do not use ink cleaner. Failure to observe this precaution could result in damaged parts.

- 1** Make sure the printer is turned off and the screen has turned off, and then unplug the power cable from the outlet.
- 2** Leave the printer for a minute.
- 3** Open the front cover.
- 4** Raise the media loading lever.

**5**

Remove stains on the pressure rollers using a dry, soft cloth.

**SC-S70600 series, SC-S50600 series**

Wipe while rotating the roller sections one by one.

**Important:**

Ensure the cloth does not touch the shaft above the rollers (gray area in the illustration) when wiping. Otherwise, grease will adhere to the cloth. If a stained cloth touches the roller, the roller is stained with grease.

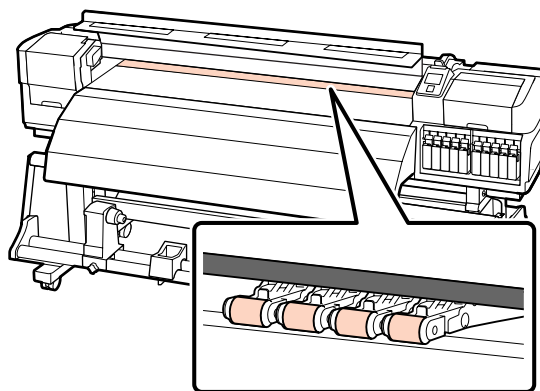

**SC-S30600 series**

Slide a dry cloth between the pressure rollers and the platen and over the upper part of the pressure rollers to wipe the area.

**Important:**

Do not press strongly on the rollers when wiping. This may detach the rollers.



**Maintenance**

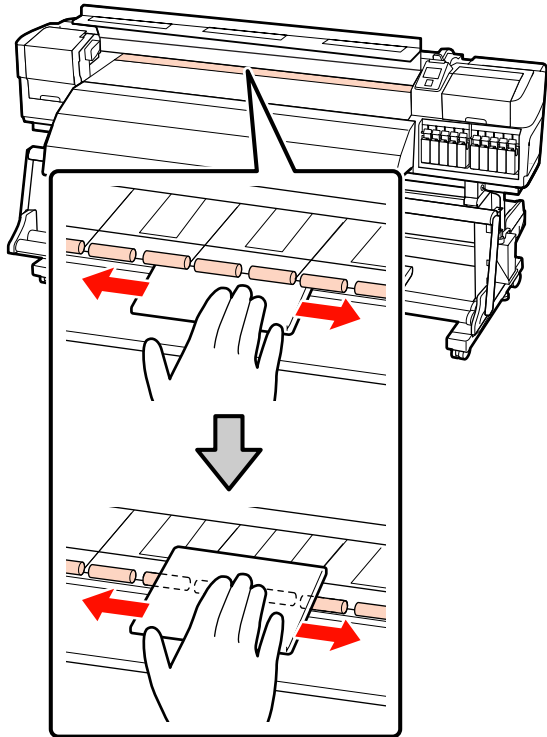

**6** Clean the platen heater and media holding plates.

Wipe lint, dust, and adhered ink with a brush or soft cloth that has been soaked in water and squeezed well.

**Platen heater**

Carefully remove lint and dust stuck in the groove of the platen.

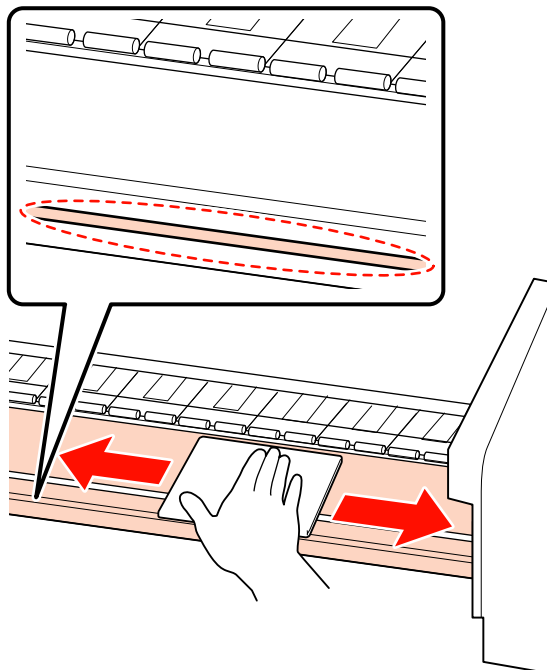

**Media holding plate**

Remove the media holding plates and wipe stains from the front and rear surfaces. If glue from media with glue on the rear side solidifies and remains, usage may result in the print head striking the media. Wipe away glue using a diluted neutral detergent.

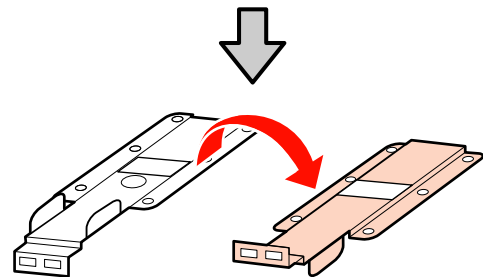
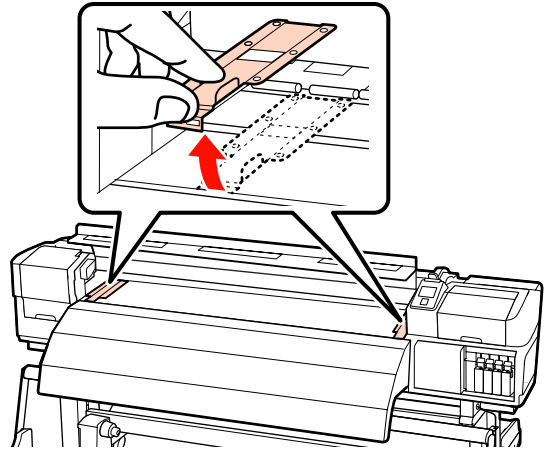

## Maintenance

- 7** Open the left maintenance cover and clean inside.

Wipe lint and dust with a brush or soft cloth that has been soaked in water and squeezed well.

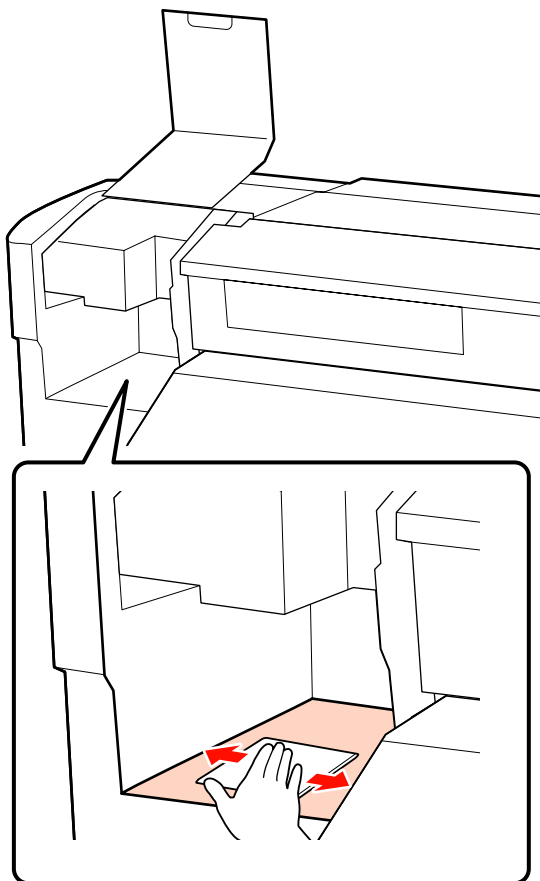

After cleaning, close the front cover and left maintenance cover.

### Cleaning the Flushing Pad

If lint or dust adhere to the surface of the flushing pad, it may contact the the print head and clog nozzles. Use the following procedure for cleaning.

- 1** Position the print head for maintenance and open the right maintenance cover.

[“Moving the Print Head” on page 89](#)

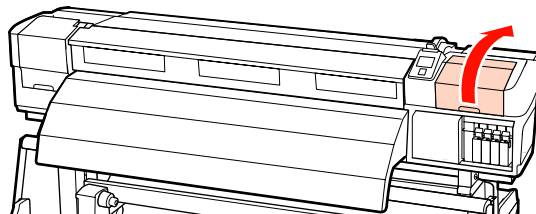

- 2** Dampen a new cleaning stick with ink cleaner.

[“Using Ink Cleaner” on page 89](#)

- 3** Clean the top surface of the flushing pad.

Wipe lint and dust with the tip of a cleaning stick.

**!** **Important:**  
Do not deform the metal section of the top surface. If they are deformed, they may damage the print head.

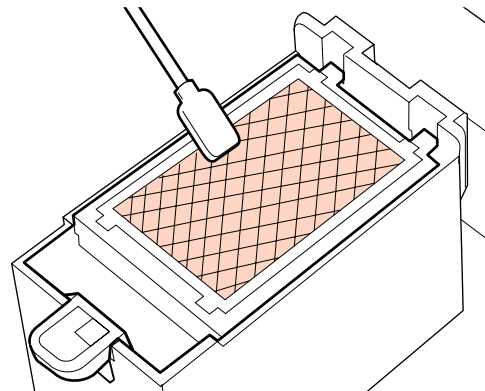

If the ink has solidified and lint and dust cannot be removed, we recommend exchanging the flushing pad with a new one.

[“Replacing the Flushing Pad” on page 105](#)

- 4** Close the maintenance cover and press the OK button twice.

The menus will close when the print head returns to its normal position.

Maintenance

# Regular Cleaning Check Sheet

Print this page to track maintenance tasks.

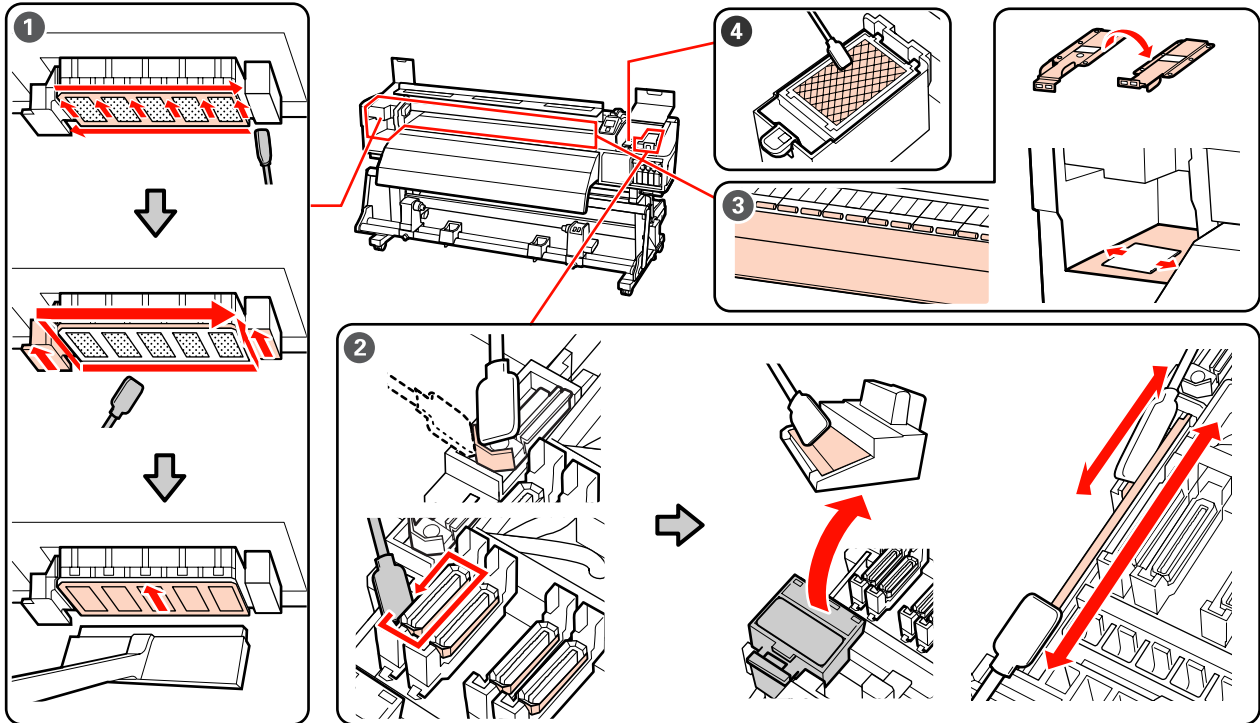

Component to be cleaned	Cleaned on date					Explanation
<b>①</b> Around the Print Head "Cleaning Around the Print Head" on page 90	/	/	/	/	/	<input type="checkbox"/> Solidified ink is difficult to remove so we recommend cleaning at the end of every workday. <input type="checkbox"/> Cleaning should also be performed if colors in the printout are faint or missing even after head cleaning has been performed.
	/	/	/	/	/	
	/	/	/	/	/	
	/	/	/	/	/	
<b>②</b> Around caps (wiper, caps, wiper cleaner, wiper rail) "Cleaning Around Caps" on page 91	/	/	/	/	/	
	/	/	/	/	/	
	/	/	/	/	/	
	/	/	/	/	/	
<b>③</b> Inside (platen heater, pressure rollers, media holding plates, and left maintenance cover interior) "Cleaning Inside the Printer" on page 96	/	/	/	/	/	<input type="checkbox"/> Aim to clean from once a week to once a month. <input type="checkbox"/> Clean if you notice ink, lint waste, or dust.
	/	/	/	/	/	
	/	/	/	/	/	
	/	/	/	/	/	

**Maintenance**

Component to be cleaned	Cleaned on date					Explanation
④ Flushing pad  <a href="#">"Cleaning the Flushing Pad" on page 98</a>	/	/	/	/	/	<input type="checkbox"/> Clean when it is not possible to remove nozzle clogs even after cleaning around the print head and around the caps.
	/	/	/	/	/	
	/	/	/	/	/	
	/	/	/	/	/	

## Maintenance

## Replacing Consumables

### Replacement and Shake of Ink Cartridges

If one of the installed ink cartridges is expended, printing cannot be performed. If an ink low warning is displayed, we recommend replacing the ink cartridge(s) as soon as possible.



**Important:**

If **Ink Cartridge Expended** appears when using spot color inks, replace the old ink cartridge with a new one promptly. If the ink expended warning is left displayed, the print head or other parts may be damaged.

If an ink cartridge is expended while printing, you can continue printing after replacing the ink cartridge. However, when replacing ink during a print job, you may see a difference in color tone depending on the drying conditions.

Supported ink cartridges [“Options and Consumable Products”](#) on page 145

Due to ink characteristics, the ink cartridges of this printer are prone to sedimentation (components settling to the bottom of the liquid). Shake a new ink cartridge before installing it. After installing it in the printer, remove and shake it periodically.

### Replacement and Shake Methods

You can use the same procedure to replace and shake all ink cartridges. In addition, you can use the same procedure to replace cleaning cartridges.



**Important:**

Epson recommends the use of genuine Epson ink cartridges. Epson cannot guarantee the quality or reliability of non-genuine ink. The use of non-genuine ink may cause damage that is not covered by Epson's warranties, and under certain circumstances, may cause erratic printer behavior. Information about non-genuine ink levels may not be displayed, and use of non-genuine ink is recorded for possible use in service support.

1

Make sure the printer is on.

2

Lift the lock lever for the cartridge you intend to replace.

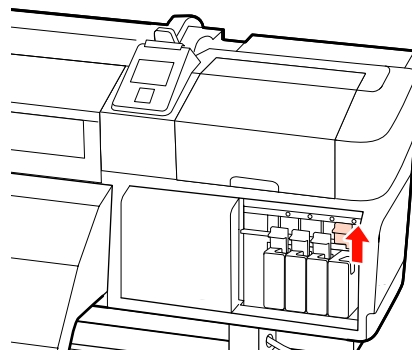

3

Insert a finger into the depression on the top of the cartridge and pull the cartridge straight toward you.

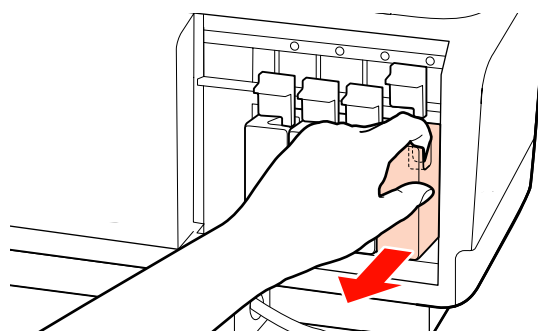

**Important:**

Removed ink cartridges may have ink around the ink supply port, so be careful not to get any ink on the surrounding area when removing the cartridges.

**Maintenance**

**4** As shown in the illustration, hold the cartridge horizontally and shake it in both directions about 5 cm each.

When replacing a cartridge, remove it from the bag and then shake it.

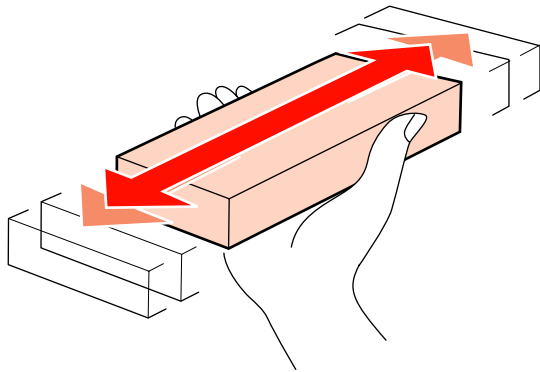

The following chart shows the number of shakes and frequency by color.

**During replacement**

Orange, Spot color ink	About 50 times within 15 seconds
Others	About 15 times within 5 seconds

**During shake**

Spot color Inks	About 15 times within 5 seconds once every 24 hours
Others	About 15 times within 5 seconds once every 3 weeks

**5** Fully insert the cartridge, keeping the color label to the front.

Match the color of the cartridge to the color of the label on the printer.

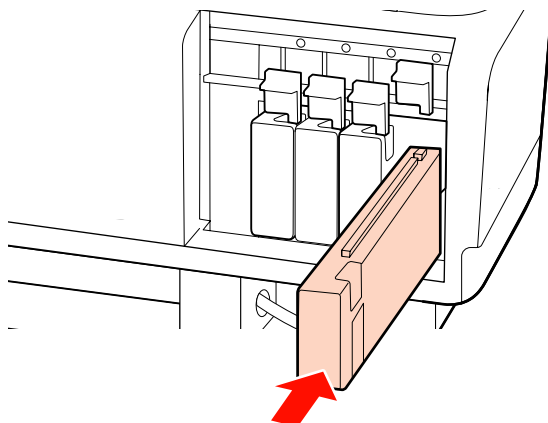

**6** Lower the lock lever to engage the latch.

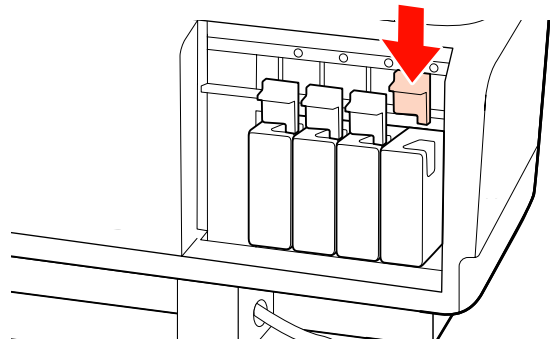

Repeat steps 2 to 6 to replace other ink cartridges.

**! Important:**  
 Fill all slots using ink or replacement cartridges (replacement cartridges are required in 8 and 4 color modes). You cannot print if any of the slots are empty.

Disposal "Disposal of used consumables" on page 106

**Disposing of Waste Ink**

**When to Dispose of Waste Ink**

Be sure to replace the waste ink bottle when the following message is displayed in the control panel.

- Prepare empty waste ink\_bottle.
- Replace waste ink bottle and press OK.

Leave the waste ink in the waste ink bottle for disposal; do not transfer it to another container.

## Maintenance

### **Caution:**

- ❑ Store waste ink in a location out of reach of children.
- ❑ Wear protective eyewear and gloves when replacing waste ink bottle.

*Should waste ink contact your skin or enter your eyes or mouth, immediately take the following actions:*

- ❑ If fluid adheres to your skin, immediately wash it off using large volumes of soapy water. Consult a physician if the skin appears irritated or is discolored.
- ❑ If fluid enters your eyes, rinse immediately with water. Failure to observe this precaution could result in bloodshot eyes or mild inflammation.
- ❑ If fluid is swallowed, consult a physician immediately; do not induce vomiting.
- ❑ After replacing waste ink bottle, wash your hands and gargle thoroughly.

### **Important:**

*Never remove the waste ink bottle during printing, head cleaning, head washing, or pre-storage maintenance. Failure to observe this precaution could cause ink to leak.*

## Waste Ink Counter

The printer uses the waste ink counter to track waste ink and displays a message when the counter reaches the warning level. If you follow the message instructions and replace the waste ink bottle, the waste ink counter is cleared automatically.

If you replace the waste ink bottle before being prompted by a message, run the Waste Ink Counter option in the Maintenance menu after replacement.

 [“The Maintenance Menu” on page 127](#)

### **Important:**

*If you replace the waste ink bottle before being prompted by a message, always clear the waste ink counter. Otherwise, the replacement interval for the waste ink bottle will no longer be notified correctly from the next message.*

## Replacing the Waste Ink Bottle

1

Remove the waste ink bottle from the waste ink bottle holder.

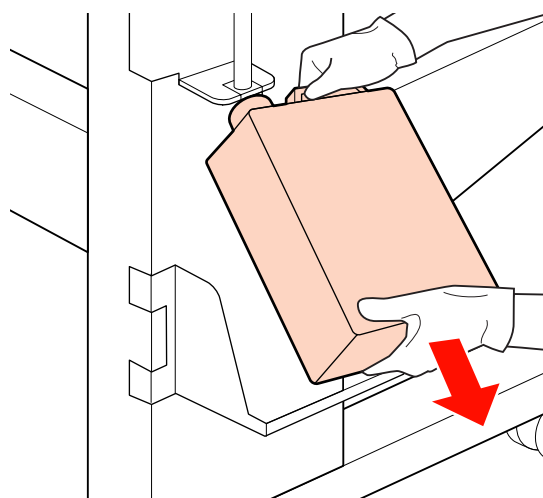
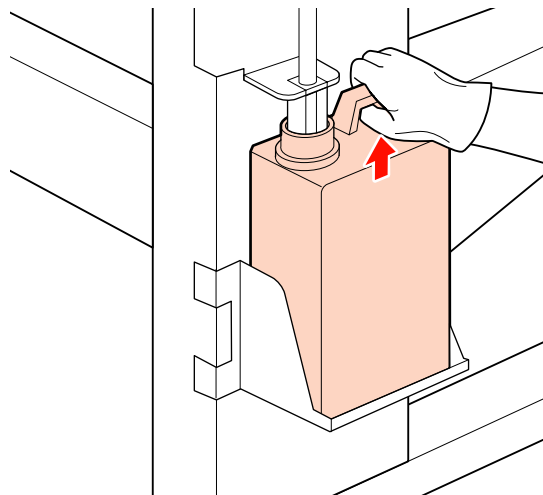

2

Insert the waste ink tube into the mouth of the new waste ink bottle and place the waste ink bottle in the holder.

Tightly seal the lid on the used waste ink bottle.

## Maintenance

**! Important:**

- ❑ Be sure to confirm that the waste ink tube is inserted in the mouth of the waste ink bottle. Ink will spill onto the surrounding area if the tube is not inserted in the bottle.
- ❑ You will need the lid for the waste ink bottle when disposing of waste ink. Keep the lid in a safe place; do not throw it out.

**3** Press the OK button.

**4** Check again to confirm that a fresh waste ink bottle is correctly placed and then press the OK button to reset the waste ink counter.

Disposal of used waste ink bottles  [“Disposal” on page 106](#)

## Replacing the Wiper and Wiper Cleaner

**1** Position the print head for maintenance and open the right maintenance cover.

 [“Moving the Print Head” on page 89](#)

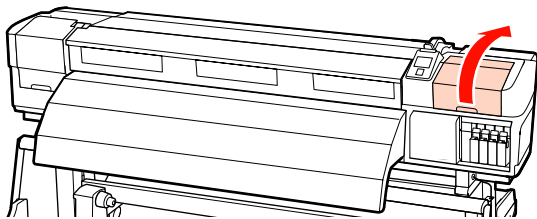

**2** Remove the wiper cleaner.

Grasp the cleaner as shown and lift it from the printer.

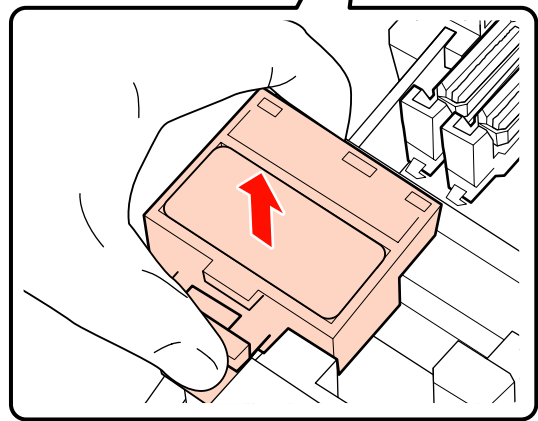
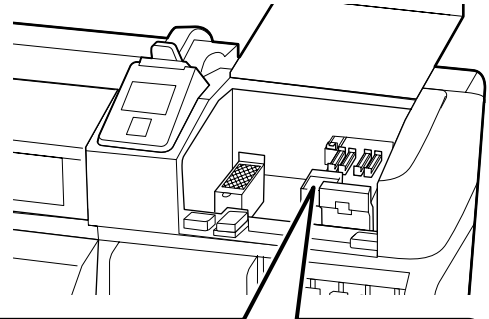

**3** Insert a new wiper cleaner.

Place on the attachment point and press down until you hear a click.

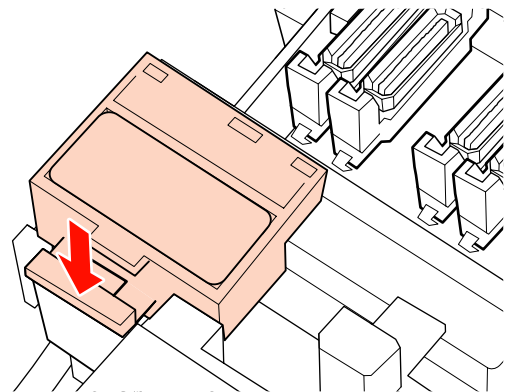



## Maintenance

### 4 Remove the wiper.

Holding the wiper by the attachment point, tilt it left and lift it out.

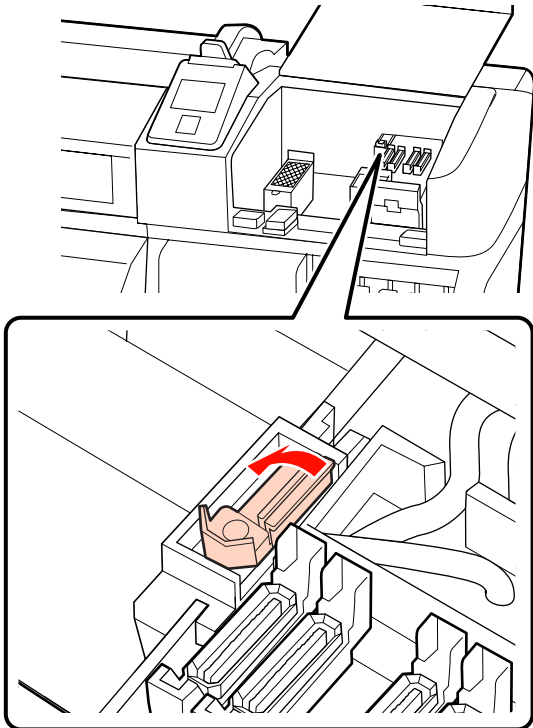

### 5 Insert new wiper.

Place on the attachment point and press down until you hear a click.

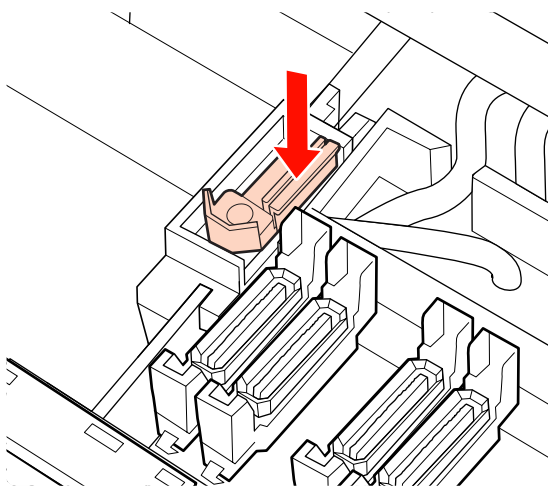

Users of the SC-S70600 series or SC-S50600 series will need to return to Step 2 and replace the remaining wiper.

### 6 When the maintenance cover is closed, the setup menu closes.

If the OK button is pressed once, the wiper moves to the inner side. If the OK button is pressed again, the print head returns to its normal position and the menu closes.

Disposal of used wipers and wiper cleaners  [“Disposal” on page 106](#)

## Replacing the Flushing Pad

### 1 Position the print head for maintenance and open the right maintenance cover.

 [“Moving the Print Head” on page 89](#)

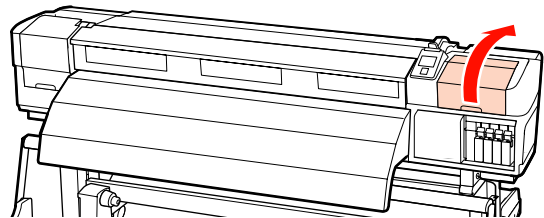

### 2 Remove the flushing pad.

Grasp the tab as shown below and lift the pad out of the printer.

## Maintenance

Wait until ink stops dripping from the bottom surface of the flushing pad. Remove the pad and then place it in the metal tray.

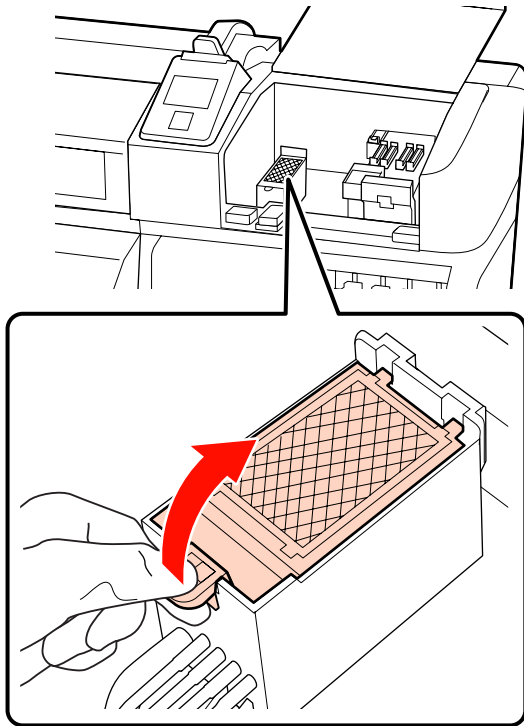

### 3 Insert a new flushing pad.

Insert the two hooks on the flushing pad into the slots as shown and press the tab down until the pad clicks into place.

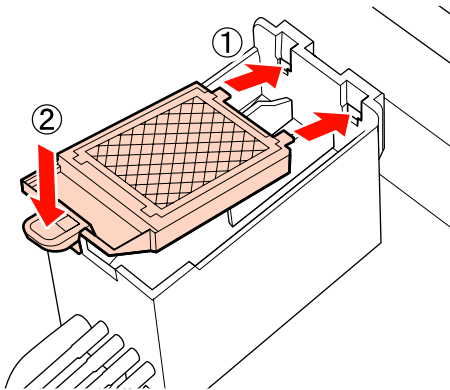

### 4 When the maintenance cover is closed, the setup menu closes.

If the OK button is pressed once, the wiper moves to the inner side. If the OK button is pressed again, the print head returns to its normal position and the menu closes.

Disposal of used flushing pads  [“Disposal” on page 106](#)

## Disposal of used consumables

### Disposal

Used waste ink bottles, and ink stained wipers, wiper cleaners, flushing pads and post-printing media are industrial waste.

Dispose of items according to local laws and regulations. For example, contract a industrial waste disposal company for disposal. In such cases, submit the safety data sheet to the industrial waste disposal company.

You can download it at your local Epson Web site.

Maintenance

# Consumable Replacement Check Sheet

Print this page to track maintenance tasks.

Purchase consumables when the maintenance kit included with the printer has been completely used or for replacement waste ink bottles.

 "Options and Consumable Products" on page 145

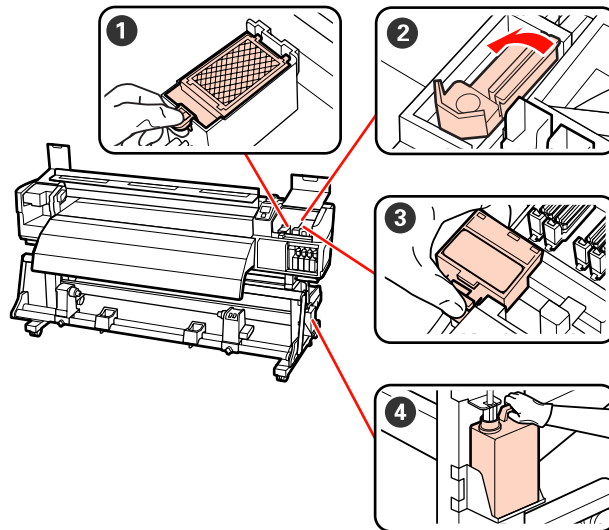

Component to be replaced	Cleaned on date					Explanation
	1	2	3	4	5	
❶ Flushing pad	/	/	/	/	/	<input type="checkbox"/> We recommend that this component be replaced once every six months. <input type="checkbox"/> Replace when ink stains appear on the media or when lint or dust on the front of the flushing pad is stuck by ink and cannot be removed.
	/	/	/	/	/	
	/	/	/	/	/	
	/	/	/	/	/	
❷ Wiper	/	/	/	/	/	<input type="checkbox"/> We recommend that this component be replaced once every six months. <input type="checkbox"/> Replace when the wiper section is worn or deteriorated. <input type="checkbox"/> Replace at the same time as the wiper cleaner.
	/	/	/	/	/	
	/	/	/	/	/	
	/	/	/	/	/	
❸ Wiper cleaner	/	/	/	/	/	<input type="checkbox"/> We recommend that this component be replaced once every six months. <input type="checkbox"/> Replace when the absorbent section are stained with adhered ink. <input type="checkbox"/> Replace at the same time as the wiper.
	/	/	/	/	/	
	/	/	/	/	/	
	/	/	/	/	/	

**Maintenance**

Component to be replaced	Cleaned on date					Explanation
<b>4</b> Waste ink bottle*	/	/	/	/	/	Place a new waste ink bottle when waste ink reaches the line on the current waste ink bottle.
	/	/	/	/	/	
	/	/	/	/	/	
	/	/	/	/	/	

\*Leave the waste ink in the waste ink bottle for disposal; do not transfer it to another container.

## Maintenance

# Other maintenance

## Checking for clogged nozzles

We recommend that you check the nozzles for clogs each time you print to ensure quality results.

### Ways to Check for Clogs

There are three ways to check for clogs.

#### ❑ Auto Nozzle Check

The printer automatically checks for clogs at specified intervals by scanning a test pattern with a sensor as it is being printed. If a clog is detected, the printer will perform a pre-selected option, either **Stop Printing** or **Continue Printing**.

🔗 “Printer Setup Menu” on page 124

#### Note:

**Auto Nozzle Check** is not available under the following conditions:

- ❑ White ink is used in 10 color mode (SC-S70600 series) or 5 color mode (SC-S50600 series). The check can still be performed with other colors.
  - ❑ The media is transparent or colored.
  - ❑ The printer is exposed to direct sunlight or interference from other ambient light sources.
- Shade the printer from sources of interference.
- ❑ 2.5 is selected for **Platen Gap** in the setup menu.

Choose another option for **Platen Gap**.

#### ❑ Print Nozzle Pattern

At specified intervals, the printer prints a test pattern at the start of normal printing. When printing is complete, you can visually inspect the pattern to determine whether there may be faint or

missing colors in the preceding or following printout.

Use **Print Nozzle Pattern** with media not suited to **Auto Nozzle Check** or if you feel that **Auto Nozzle Check** would take too long.

🔗 “Printer Setup Menu” on page 124

#### ❑ On-Demand Nozzle Pattern

Nozzle patterns can be printed as required and inspected visually to determine whether the nozzles are clogged.

This section explains how to print and inspect a check pattern.

Buttons that are used in the following settings

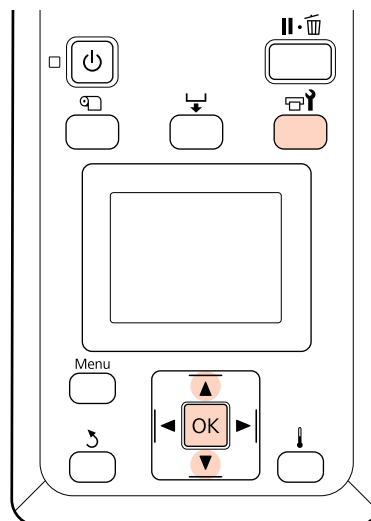

- 1 After confirming that the printer is ready, press the button.

The Maintenance menu will be displayed.

- 2 Select **Nozzle Check** and press the OK button.

- 3 A nozzle pattern will be printed.



## Maintenance

**3** Choose the nozzles to be cleaned.

### All Nozzles

Choose this option if all patterns in the printed nozzle check results contain faint or missing segments. If you select **All Nozzles**, proceed to Step 5.

### Selected Nozzles

Choose this option if only some of the numbered patterns (nozzle arrays) in the printed nozzle check results contained faint or missing segments. You can select multiple nozzle arrays.

**4** Choose the nozzle arrays to be cleaned.

- Use the ▼/▲ buttons to choose the nozzle arrays with faint or missing segments in the nozzle check pattern and press the OK button.
- After selecting the arrays you wish to clean, select **Proceed** and press the OK button.

**5** Select a cleaning level and press the OK button.

**6** Head cleaning will be performed.

The menu will close when cleaning is complete. Print a nozzle pattern and inspect the results to determine whether the problem has been resolved.

[“Checking for clogged nozzles” on page 109](#)

If you paused the printer in Step 1, printing will resume when head cleaning is complete; check the printout to confirm whether the problem has been resolved.

If nozzle clogs cannot be cleared even after repeated head cleaning, the area around the print head maybe stained. See the following sections and clean each part.

[“Cleaning Around the Print Head” on page 90](#)

[“Cleaning Around Caps” on page 91](#)

[“Cleaning the Flushing Pad” on page 98](#)

If nozzle clogs cannot be cleared by cleaning, perform **Head Washing** in the Maintenance menu.

[“The Maintenance Menu” on page 127](#)

On the SC-S70600 series or SC-S50600 series, if only one print head has a nozzle clog that cannot be cleared by **Head Washing**, you can continue printing with the unclogged head using the **Head Mode** setting in the Printer Setup menu.

[“Printer Setup Menu” on page 124](#)

## Ink Circulation and Ink Refresh

When you notice uneven colors (areas of uneven density) in print results for spot color inks, run **Ink Circulation**.

When you notice uneven colors in print results of spot color inks once the printer is turned on following a period of disuse, run Ink Refresh.

Buttons that are used in the following settings

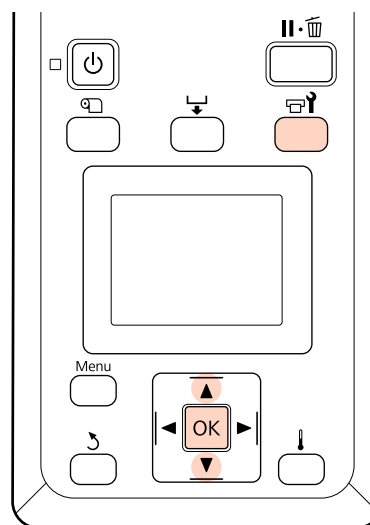

**1** Pressing the  button when the printer is ready displays the Maintenance menu.

**2** Use the ▼/▲ buttons to select the menu item to run and press the OK button.

### Ink Circulation

Select **Ink Circulation**.

## Maintenance

### Ink Refresh

For the SC-S70600 series, select **WH, MS Ink Refresh**. For the SC-S50600 series, select **WH, WH Ink Refresh**.

The printer will perform Ink Circulation or Ink Refresh.

## Long-term Storage (Pre-storage Maintenance)

If the printer will not be used for an extended period (and switched off), perform **Pre-Storage Maint.** before storage. Failure to perform pre-storage maintenance causes permanent clogs.

Use cleaning cartridges (available separately) during **Pre-Storage Maint.**

The following chart shows the storage interval guidelines for **Pre-Storage Maint.** and the necessary number of cleaning cartridges by printer model.

### SC-S70600 series (10 colors)

Interval	Cartridges	Colors
7 to 13 days*	2	WH/MS
2 weeks or more	10	All Nozzles (All colors)

\* If the storage interval is short, you can perform **Pre-Storage Maint.** for spot color ink only.

### SC-S70600 series (8 colors)

Interval	Cartridges	Colors
2 weeks or more	8	All Nozzles (All colors)

### SC-S50600 series (5 colors)

Interval	Cartridges	Colors
7 to 20 days*	2	WH/WH
3 weeks or more	10	All Nozzles (All colors)

\* If the storage interval is short, you can perform **Pre-Storage Maint.** for spot color ink only.

### SC-S50600 series (4 colors)

Interval	Cartridges	Colors
3 weeks or more	8	All Nozzles (All colors)

### SC-S30600 series

Interval	Cartridges	Colors
1 month or more	4	All Nozzles (All colors)



#### Important:

After performing **Pre-Storage Maint.** for spot color ink only, you must charge spot color ink if you want to change **Pre-Storage Maint.** to **All Nozzles**.

## Pre-Storage Operations

Buttons that are used in the following settings

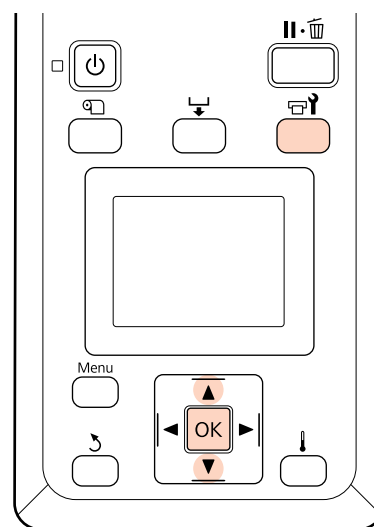



1

Confirm that the printer is on and press .

The Maintenance menu will be displayed.

2

Use the / buttons to select **Pre-Storage Maint. - All Nozzles** and press the OK button.

When using spot color inks, you can select **WH/MS** (SC-S70600 series)/**WH/WH** (SC-S50600 series) or **All Nozzles** according to the storage interval.

Follow the instructions on the screen.



## Maintenance

Observe the following cautions when storing the printer and ink cartridges that were removed during use.

 [“Notes when not using the printer” on page 25](#)

 [“Notes on handling ink cartridges” on page 26](#)

### Restarting use of the printer



**Important:**

*When restarting use of the printer, charge the printer with ink. When charging using removed ink cartridges, have new ink cartridges on hand as a precaution.*

Switch on the power and follow the on-screen instructions.

When first printing after restarting use, perform a nozzle check and check that there are no clogs.

 [“Checking for clogged nozzles” on page 109](#)

## Parts That Are Periodically Replaced

The following parts require periodic replacement.

**Print head:** The time until the print head needs to be replaced varies with the conditions of use.

When replacing the print head, you will also need to replace the dumper kit and carriage encoder.

The message **Print head is nearing end of its service life** is displayed in the control panel as the time for replacement draws near. The printer can still be used while this message is displayed.

**Note:**

*The message might not be displayed depending on your area.*

Print head life varies with operating conditions. Base the decision to replace the print head on the quality of the print results.

Contact your dealer or Epson Support for information on replacing components.

Component status can be printed by selecting **Print Status Sheet** in the setup menu.

 [“The Printer Status Menu” on page 129](#)

Using the Control Panel Menu

# Using the Control Panel Menu

## Menu Operations

The menus are used as shown below.

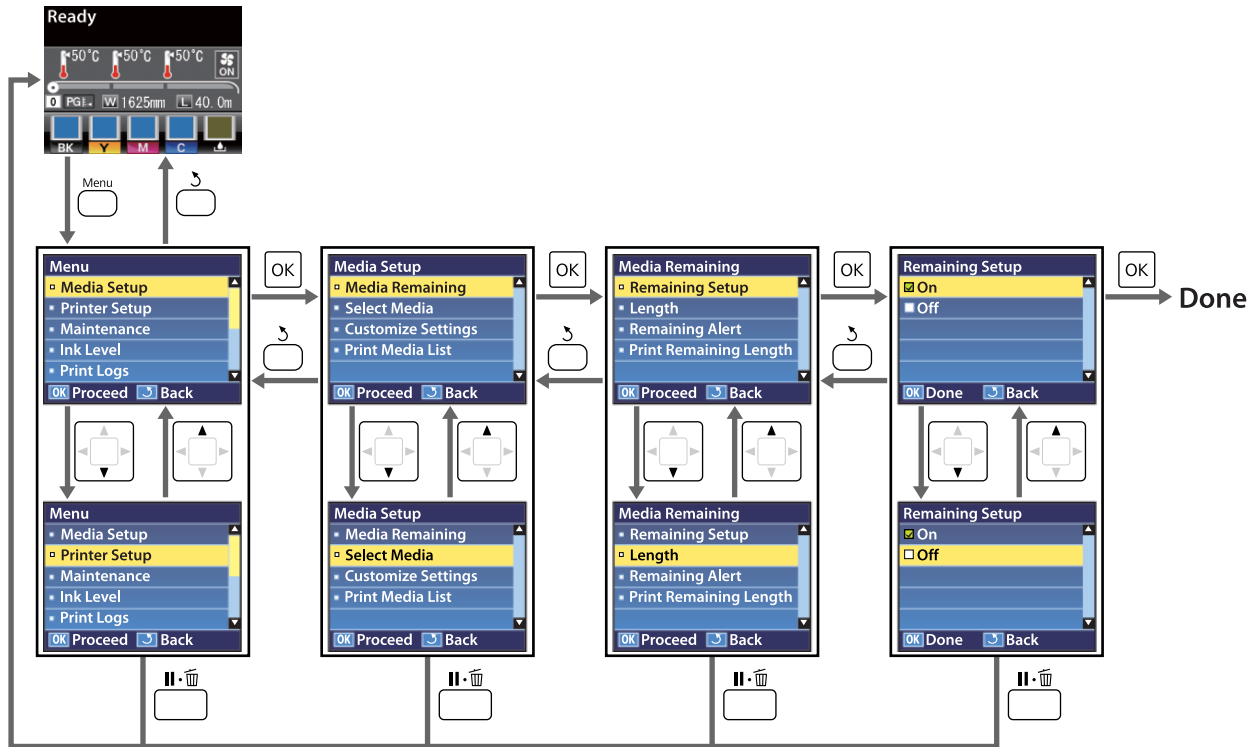

## Using the Control Panel Menu

# Menu List

The following items and parameters can be set and executed in the Menu. See the reference pages for more details on each item.

Setting items and setting values marked with asterisks indicate the following printer models.

\*1: SC-S70600 series and SC-S50600 series only supported \*2: SC-S50600 series only supported \*3: SC-S30600 series only supported \*4:SC-S70600 series only supported

Menu	Item	Parameter
Media Setup  <a href="#">"The Media Setup Menu" on page 120</a>	Media Remaining	
	Remaining Setup	On, Off
	Length	1.0 to 999.5 m (3 to 3000 ft)
	Remaining Alert	1 to 15 m (4 to 50 ft)
	Print Remaining Length	Print
	Select Media	RIP Settings, 1 to 30 (media setting bank number)
	Customize Settings	
	Current Settings	Change settings for currently selected media. The options available depend on whether <b>RIP Settings</b> or a media setting bank is selected. More information on the options available can be found below in the entries for RIP Settings and media setting banks 1 to 30.
	RIP Settings	
	Platen Gap	1.5, 2.0, 2.5
	Head Alignment	
	Input thickness.	Auto(Uni-D), Auto(Bi-D), Auto(Dual Head) <sup>*1</sup> , Manual(Uni-D), Manual(Bi-D), Manual(Dual Head) <sup>*1</sup>
	Roll Type	Printable Side Out, Printable Side In
	Tension Measurement	Periodically, Every Page, Off
	Media Tension	0 to 40
	Restore Settings	Yes, No
	1 to 30 (media setting bank number)	
	Setting Name	Up to 22 half-size characters
	Feed Adjustment	Auto, Manual
	Platen Gap	1.5, 2.0, 2.5
	Head Alignment	Auto(Uni-D), Auto(Bi-D), Auto(Dual Head) <sup>*1</sup> , Manual(Uni-D), Manual(Bi-D), Manual(Dual Head) <sup>*1</sup>

### Using the Control Panel Menu

Menu	Item	Parameter
	Heating & Drying	
	Heater Temperature	Pre-heater/platen heater: 30 °C to 50 °C (86 °F to 122 °F) After heater: 30 °C to 55 °C (86 °F to 131 °F)
	Drying Time Per Pass	0 to 10sec
	After Heater Feed	Mode 1, Mode 2, Off
	Additional Dryer	On, Off
	Media Suction	0 to 10
	Head Movement	Data Width, Printer Full Width
	Multi-Strike Printing	Off, 2 to 8
	Roll Type	Printable Side Out, Printable Side In
	Tension Measurement	Periodically, Every Page, Off
	Media Tension	0 to 40
	Feed Speed	1, 2
	Restore Settings	Yes, No
	Print Media List	Print



## Using the Control Panel Menu

Menu	Item	Parameter	
Printer Setup  "Printer Setup Menu" on page 124	Side Margin(Right)	3 to 25 mm (0.12 to 1.00inch)	
	Side Margin(Left)	3 to 25 mm (0.12 to 1.00inch)	
	Print Start Position	0 to 800 mm (0.00 to 32.00 inch)	
	Media Size Check	On, Off	
	Media End Check	On, Off	
	Media Skew Check	On, Off	
	Head Strike Warning* <sup>2</sup>		
	Warning Options	On, Off	
	Warning Level Options	1 to 5	
	Auto Nozzle Check		
	Nozzle Check Cycle	Off, 1 to 10 pages	
	Options When Clogged	Continue Printing, Stop Printing	
	Print Nozzle Pattern	Off, 1 to 10 pages	
	Periodical Cleaning		
	Light	Off, 1 to 240 hours	
	Medium		
	Heavy		
	Power* <sup>3</sup>		
	Cleaning Cycle	Off, 1 to 10 pages	
	Heat Off Timer	15 to 240 minutes	
Head Mode* <sup>1</sup>	2 Heads Mode, Head 1, Head 2		
Restore Settings	Yes, No		

### Using the Control Panel Menu

Menu	Item	Parameter
Maintenance <a href="#">☞ "The Maintenance Menu" on page 127</a>	Nozzle Check	Print
	Cleaning	
	All Nozzles	Execute (Light), Execute (Medium), Execute (Heavy)
	Head 1/Head 2* <sup>1</sup> , Head 1* <sup>1</sup> , Head 2* <sup>1</sup>	
	Selected Nozzles	Execute (Light), Execute (Medium), Execute (Heavy)
	Head Maintenance	Move Head
	Waste Ink Counter	-
	Ink Circulation* <sup>1</sup>	Execute
	WH, XX Ink Refresh* <sup>1</sup>	Execute
	Head Washing	XX/XX (nozzle array number), All Nozzles* <sup>3</sup> , * <sup>4</sup> Head1 XX/XX (nozzle array number), Head2 XX/XX (nozzle array number), Head1 All Nozzles, Head2 All Nozzles, Head1,2 All Nozzles* <sup>2</sup>
Pre-Storage Maint.	WH/MS* <sup>4</sup> , WH/WH* <sup>2</sup> , All Nozzles	
Ink Level <a href="#">☞ "The Ink Level Menu" on page 129</a>		
Print Logs <a href="#">☞ "The Print Logs Menu" on page 129</a>	Print Job Log Sheet	Print
	Show Total Prints	XXXXXXm <sup>2</sup> (XXXXXX ft <sup>2</sup> )
Printer Status <a href="#">☞ "The Printer Status Menu" on page 129</a>	Print Status Sheet	Print
	myEpsonPrinter Status	Not Started, Disabled, Enabled Last Uploaded:, (Not Uploaded), MM/DD/YY HH:MM GMT
	Firmware Version	XXXXXXXX,X_XX,XXXX

## Using the Control Panel Menu

Menu	Item	Parameter
Network Setup  "The Network Setup Menu" on page 129	IP Address Setting	
	Auto	-
	Panel	IP: 000.000.000.000 – 255.255.255.255 SM: 000.000.000.000 – 255.255.255.255 DG: 000.000.000.000 – 255.255.255.255
	Bonjour	On, Off
	Print Status Sheet	Print
	Restore Settings	Yes, No
Preference  "The Preference Menu" on page 130	Date And Time	MM/DD/YY HH:MM
	Language	Japanese, English, French, Italian, German, Portuguese, Spanish, Dutch, Russian, Korean, Chinese
	Unit: Length	m, ft/in
	Unit: Temperature	°C, F
	Alert Sound Setting	On, Off
	Alert Lamp Setting	On, Off
Reset All Settings  "The Reset All Settings Menu" on page 131		Yes, No

## Using the Control Panel Menu

# Details of the Menu

Setting items and setting values marked with asterisks indicate the following printer models.

\*1: SC-S70600 series and SC-S50600 series only supported \*2: SC-S50600 series only supported \*3: SC-S30600 series only supported \*4:SC-S70600 series only supported

---

## The Media Setup Menu

The Media Setup menu can be accessed directly by pressing the  button.

 indicates default settings.

### Media Remaining

Item	Parameter	Explanation
Remaining Setup	On	Choose <b>On</b> to display and record, or <b>Off</b> to not display and not record, the amount of media remaining. <b>Length</b> , <b>Remaining Alert</b> , and <b>Print Remaining Length</b> options are available when <b>On</b> is selected. The display panel shows the amount of media remaining based on the value selected for <b>Length</b> and the amount of media used during printing.
	Off	
Length	1.0 to 999.5 m (3 to 3000 ft)	Enter a value for overall roll length between 5.0 and 999.5 m (15 to 3000 ft). You can set in 0.5m (1ft) increments.
Remaining Alert	1 to 15 m (4 to 50 ft)	An alert will be displayed if the amount of media remaining reaches this length. Choose from values between 1 and 15 m (4 and 50 ft). You can set in 0.5m (1ft) increments.
Print Remaining Length	Print	Use <b>Print Remaining Length</b> to print the amount of media remaining on the current roll before replacing it with another type of media. You can then enter this number as the media the length the next time the roll is used.

### Select Media

Parameter	Explanation
RIP Settings	Choose the media settings used for printing.
1 to 30 (media setting bank number)	If <b>RIP Settings</b> is selected, the media settings selected in the software RIP will be used.  Select a number between 1 and 30 to use the settings in the corresponding media setting bank. Use <b>Customize Settings</b> to create media setting banks.





## Using the Control Panel Menu

### Customize Settings

Item	Parameter	Explanation
Current Settings		Change settings for currently selected media. The options available depend on whether <b>RIP Settings</b> or a media setting bank is selected. More information on the options available can be found below in the entries for RIP Settings and media setting banks 1 to 30.

### RIP Settings

Item	Parameter	Explanation
Platen Gap	1.5	Change <b>Platen Gap</b> (the gap between the print head and the media) for the media setting bank selected in the software RIP.  The default setting of 1.5 is recommended in most situations. Choose 2.0 if printout is scratched or smudged. Select 2.5 only if print results are still smudged when 2.0 is selected. Choosing a larger gap than required may result in ink stains inside the printer, reduced print quality, or shorter product life.
	2.0	
	2.5	
Head Alignment		
Input thickness.	0.1 to 1.0 mm (4 to 40 mil)	Enter a value for media thickness of from 0.1 to 1.0 mm (4 to 60 mil).
	Auto(Uni-D)	Print  Select Head Alignment to realign the print head when print results seem grainy or out of focus. Auto adjustment aligns the head automatically using data collected by a sensor while a test pattern is printed.  <a href="#">"Head Alignment" on page 72</a>  In manual adjustment, you need to check the pattern and enter the optimum adjustment value for alignment.  <a href="#">"Head Alignment (Manual Adjustment)" on page 75</a>
	Auto(Bi-D)	
	Auto(Dual Head)*1	
	Manual(Uni-D)	
	Manual(Bi-D)	
	Manual(Dual Head)*1	
Roll Type	Printable Side Out	Choose <b>Printable Side Out</b> or <b>Printable Side In</b> according to how the media is rolled.
	Printable Side In	
Tension Measurement	Periodically	Choose <b>Periodically</b> or <b>Every Page</b> to have the printer automatically monitor and adjust media tension during printing for optimal results, <b>Off</b> to disable automatic tension adjustment.  <b>Periodically</b> is recommended in most circumstances.  The printer may however be unable to adjust tension appropriately for some media, resulting in excessive slack or other maladjustments that cause printing problems, in which case you should select <b>Off</b> . Note, however, that <b>Off</b> may result in unusually large margin between pages. In addition, printing may not stop and the inside of the printer may become stained. Observe the following precautions:  <input type="checkbox"/> Do not print at the end of a roll <input type="checkbox"/> Do not select <b>Off</b> for Media End Check.  Select <b>Every Page</b> for more precise tensioning, but note that print times will increase.
	Every Page	
	Off	

## Using the Control Panel Menu

Item	Parameter	Explanation
Media Tension	0 to 40	Increase tension if creases appear in the media during printing. The higher the value, the greater the tension.
Restore Settings	Yes	If <b>Yes</b> is selected, the content of configured RIP Settings are returned to the default settings.
	No	

### 1 to 30 (media setting bank number)

Item	Parameter	Explanation
Setting Name		Assign the media setting bank a name up to 22 half-size characters long. Using distinctive names makes it easier to select banks for use.
Feed Adjustment	Auto	Use this option if banding (horizontal banding, lines, or strips of uneven color) persists after head cleaning and head alignment have been performed.  Auto feed adjustment adjusts the feed automatically using data collected by a sensor while a test pattern is printed. <a href="#">☞ "Feed Adjustment" on page 71</a>  In manual feed adjustment, the user visually inspects print results and enters the adjustment value by hand. <a href="#">☞ "Feed Adjustment (Manual Feed Adjustment)" on page 77</a>
	Manual	
Platen Gap	1.5	Choose the platen gap (the distance between the print head and the media).  The default setting of 1.5 is recommended in most situations. Choose 2.0 if printout is scratched or smudged. Select 2.5 only if print results are still smudged when 2.0 is selected. Choosing a larger gap than required may result in ink stains inside the printer, reduced print quality, or shorter product life.
	2.0	
	2.5	
Head Alignment	Auto(Uni-D)	Select Head Alignment to realign the print head when print results seem grainy or out of focus. Auto adjustment aligns the head automatically using data collected by a sensor while a test pattern is printed. <a href="#">☞ "Head Alignment" on page 72</a>
	Auto(Bi-D)	
	Auto(Dual Head)*1	In manual adjustment, you need to check the pattern and enter the optimum adjustment value for alignment. <a href="#">☞ "Head Alignment (Manual Adjustment)" on page 75</a>
	Manual(Uni-D)	
	Manual(Bi-D)	
	Manual(Dual Head)*1	
Heating & Drying		

## Using the Control Panel Menu

Item	Parameter	Explanation	
Heater Temperature	Pre-heater/platen heater: 30 °C to 50 °C (86 °F to 122 °F) After heater: 30 °C to 55 °C (86 °F to 131 °F)	The temperatures for the pre-, platen, and after heaters can each be adjusted separately.	
	Drying Time Per Pass	0 to 10sec  Select the time the print head pauses to allow drying after each pass. Choose from values between 0.0 and 10.0 seconds. The time needed for the ink to dry varies with ink density and the media used. If the ink blurs on the media, set a longer time for drying the ink.  Increasing the drying time increases the time needed to print.	
	After Heater Feed	Mode 1	To feed media to the after heater after printing, choose <b>Mode 1</b> or <b>Mode 2</b> ; otherwise, choose <b>Off</b> .  If <b>Mode 1</b> is selected, the portion fed for drying will not be rewound before the next job starts. Select this option if the media will be cut before the next job starts.  If <b>Mode 2</b> is selected, the portion fed for drying will be rewound before the next job starts, eliminating unnecessary margin. Select this option if multiple jobs will be printed consecutively.
		Mode 2	
Off			
Additional Dryer	On	Select <b>On</b> to enable, or <b>Off</b> to disable, the additional print drying system (supplied with the SC-S50600 series; optional with other models). Note that even when <b>On</b> is selected, the additional print drying system will turn off with the heaters when the Heat Off Timer expires. The additional print drying system will turn back on when the heaters resume operation. Heat Off Timer  "Printer Setup Menu" on page 124  This item is displayed only when the additional print drying system (supplied with the SC-S50600 series; optional with other models) is installed.	
	Off		
Media Suction	0 to 10	Suction is required to maintain the correct distance between the media and the print head; the amount needed varies with the type of media. Excessive suction can increase the gap between the print head and thin or flexible media, potentially reducing print quality or preventing the media feeding normally. In such cases, you will need to lower media suction. The suction power is weakened when the parameter is lowered.	
Head Movement	Data Width	Choose the range in which the print head moves during printing.  <b>Data Width</b> restricts print head movement to the printed area. Restricting the extent of print head movement increases print speed.	
	Printer Full Width	If <b>Printer Full Width</b> is selected, the print head will move the full width of the largest media supported by the printer. Select this option for more even print results with less variation.	
Multi-Strike Printing	Off	Choose the number of times each line is printed.	
	2 to 8		
Roll Type	Printable Side Out	Choose <b>Printable Side Out</b> or <b>Printable Side In</b> according to how the media is rolled.	
	Printable Side In		

## Using the Control Panel Menu



Item	Parameter	Explanation
Tension Measurement	Periodically	<p>Choose <b>Periodically</b> or <b>Every Page</b> to have the printer automatically monitor and adjust media tension during printing for optimal results, <b>Off</b> to disable automatic tension adjustment.</p> <p><b>Periodically</b> is recommended in most circumstances.</p> <p>The printer may however be unable to adjust tension appropriately for some media, resulting in excessive slack or other maladjustments that cause printing problems, in which case you should select <b>Off</b>. Note, however, that <b>Off</b> may result in unusually large margin between pages. In addition, printing may not stop and the inside of the printer may become stained. Observe the following precautions:</p> <ul style="list-style-type: none"> <li><input type="checkbox"/> Do not print at the end of a roll</li> <li><input type="checkbox"/> Do not select <b>Off</b> for Media End Check.</li> </ul> <p>Select <b>Every Page</b> for more precise tensioning, but note that print times will increase.</p>
	Every Page	
	Off	
Media Tension	0 to 40	Increase tension if creases appear in the media during printing. The higher the value, the greater the tension.
Feed Speed	1 to 2	Choose a slower feed speed if thin media is creased or torn or sticks together during printing. The lower the value, the slower the speed.
Restore Settings	Yes	If <b>Yes</b> is selected, the setting content of selected media settings are returned to the default settings.
	No	

## Print Media List

Parameter	Explanation
Print	Print the contents of media setting banks 1 to 30.

## Printer Setup Menu

 indicates default settings.

Item	Parameter	Explanation
Side Margin(Right)	3 to 25 mm (0.12 to 1.00inch)	<p>Choose the width of the right margin when media is loaded in the printer. Margin widths vary with the model of printer used. See the following for more information.</p> <p> <a href="#">"Printable area" on page 80</a></p>
Side Margin(Left)	3 to 25 mm (0.12 to 1.00inch)	<p>Choose the width of the left margin when media is loaded in the printer. Margin widths vary with the model of printer used. See the following for more information.</p> <p> <a href="#">"Printable area" on page 80</a></p>

## Using the Control Panel Menu

Item	Parameter	Explanation
Print Start Position	0 to 800 mm (0.00 to 32.00 inch)	Adjust this parameter if you want to print from the near center of the media or if you want to shift the printed area left from the <b>Side Margin(Right)</b> setting. The area between the right edge of the media and <b>Print Start Position</b> is left blank. If a value is selected for <b>Side Margin(Right)</b> , an additional area corresponding to the width selected for <b>Side Margin(Right)</b> will be left blank. Margin widths vary with the model of printer used. See the following for more information.   <a href="#">"Printable area" on page 80</a>
Media Size Check	On	Choose whether the printer automatically detects ( <b>On</b> ), or does not automatically detect ( <b>Off</b> ), the edges of the media. Try <b>Off</b> if the printer displays a <b>Media Size Error</b> when the media is correctly loaded. Note, however, that the printer may print beyond the edges of the media when <b>Off</b> is selected. Ink used outside the edges of the media will stain the inside of the printer. We generally recommend to operate with this setting set to <b>On</b> .
	Off	
Media End Check	On	Choose whether the printer automatically detects ( <b>On</b> ) or does not automatically detect ( <b>Off</b> ), the end of the media. Try <b>Off</b> if the printer displays <b>Media Out</b> when the media is correctly loaded. We generally recommend to operate with this setting set to <b>On</b> .
	Off	
Media Skew Check	On	When skewed media is detected, the printer will either stop printing and display an error ( <b>On</b> ) or continue printing ( <b>Off</b> ). <b>On</b> is recommended in most circumstances, as skewed media may cause the printer to jam.
	Off	
Head Strike Warning* <sup>2</sup>		
Warning Options	Off	Choose whether the printer automatically detects (On) or does not automatically detect (Off), the media lifting during printing.  If On is selected, the printer will stop when the media lifts to prevent a head strike.  On is recommended if you will be performing other tasks and are unable to give the printer your full attention during printing.  The printer may fail to detect the media lifting in the following instances even when On is selected.  <input type="checkbox"/> Off is selected for <b>Media Size Check</b> <input type="checkbox"/> The <b>Platen Gap</b> is set to 2.5 <input type="checkbox"/> Transparent film media is used <input type="checkbox"/> The media has a high gloss
	On	
Warning Level Options	1 to 5	The higher the value, the more sensitive the printer to media lift. Choose lower values to reduce the number of stoppages.
Auto Nozzle Check		

## Using the Control Panel Menu



Item	Parameter	Explanation	
Nozzle Check Cycle	Off	<p>Choose the frequency with which the printer performs an <b>Auto Nozzle Check</b>: never (<b>Off</b>) or once every <b>1 to 10</b> pages. Auto nozzle checks will not be performed while <b>Off</b> is selected. If <b>1 to 10</b> is selected, the printer will automatically check for clogs at the specified interval by scanning a test pattern with a sensor as it is being printed.</p> <p>Note that <b>Auto Nozzle Check</b> is not capable of detecting all types of clog. In addition, <b>Auto Nozzle Check</b> is not available under the following conditions:</p> <ul style="list-style-type: none"> <li><input type="checkbox"/> The media is transparent or colored.</li> <li><input type="checkbox"/> The printer is exposed to direct sunlight or interference from other ambient light sources.</li> </ul> <p style="padding-left: 20px;">Shade the printer from sources of interference.</p> <li><input type="checkbox"/> <b>2.5</b> is selected for <b>Platen Gap</b> in the setup menu.</li> <p style="padding-left: 20px;">Choose another option for <b>Platen Gap</b>.</p>	
	1 to 10 pages		
Options When Clogged	Continue Printing	<p>Choose how the printer responds when an auto nozzle check detects clogged nozzles.</p> <p>If <b>Continue Printing</b> is selected, the printer will display <b>Nozzle Clog Detected</b> but keep printing. Stop printing and perform head cleaning if you judge it necessary on inspecting the print results.</p>	
	Stop Printing	<p>If <b>Stop Printing</b> is selected, the printer will display <b>Nozzle Clog Detected</b> and pause printing. Inspect the print results and choose whether to resume or suspend printing according to the extent of the clog.</p>	
Print Nozzle Pattern	Off	<p>Choose the frequency with which the printer prints a nozzle test pattern: never (<b>Off</b>) or once every <b>1 to 10</b> pages. Periodic test patterns will not be printed while <b>Off</b> is selected. To print a test pattern at the top of every 1 to 10 pages, select an option between <b>1</b> and <b>10</b>. When printing is complete, you can visually inspect the pattern to determine whether there may be faint or missing colors in the preceding or following printout.</p>	
	1 to 10 pages		
Periodical Cleaning			
Light	Off/1 to 240 hours	<p>Choose the frequency—never (<b>Off</b>) or after <b>1 to 240</b> hours—and strength with which the printer performs head cleaning. Periodical Cleaning will not be performed while <b>Off</b> is selected. If a value between <b>1</b> and <b>240</b> hours is selected, auto head cleaning will be performed after the specified number of hours. If printing is in progress or the printer is in sleep mode when the specified time has elapsed, Periodical Cleaning will only be performed after printing is complete or the printer is reactivated.</p> <p>The following reset the timer:</p> <ul style="list-style-type: none"> <li><input type="checkbox"/> Turning the printer on.</li> <li><input type="checkbox"/> Choosing another option for this item.</li> <li><input type="checkbox"/> Manually performing head cleaning using All Nozzles.</li> </ul> <p>Note that even when <b>Off</b> is selected for Periodical Cleaning, the printer will automatically clean the print head at a fixed interval after printing to keep the nozzle from clogging.</p>	
			Medium
			Heavy
			Power <sup>*3</sup>
Cleaning Cycle	Off	<p>Choose the frequency with which the printer performs auto head cleaning: never (<b>Off</b>) or once every <b>1 to 10</b> pages. Head cleaning will not be performed while <b>Off</b> is selected. Select <b>1 to 10</b> to perform head cleaning before the specified number of pages is printed.</p>	
	1 to 10 pages		

## Using the Control Panel Menu





Item	Parameter	Explanation
Heat Off Timer	15 to 240 minutes	<p>You can turn off the heaters automatically when no errors are detected and no print jobs are in progress. This option is used to choose the interval before the heaters turn off automatically.</p> <p>The printer will enter sleep mode when the Heat Off Timer expires. In sleep mode, the control panel turns off and the internal motors and other components consume less power. If an additional print drying system (supplied with the SC-S50600 series; optional with other models) is installed, it will turn off automatically.</p> <p>To reactivate the control panel display, press any button in the control panel except . The control panel display will however turn off again if no operations are performed for another 30 seconds under these conditions. The printer and heaters are only fully reactivated when a print job is received, the media loading lever is used, or another operation involving printer hardware is performed.</p>
Head Mode* <sup>1</sup>	2 Heads Mode	Use in <b>2 Heads Mode</b> in most situations.
	Head 1	<p>For example, if there is a clogged nozzle in a single print head and the clog cannot be cleared after repeated head cleaning, you continue printing using the unclogged print head. This feature is convenient because printing can continue during work time and head cleaning and other maintenance can be done after work.</p> <p>Check the check pattern printed in the <b>Nozzle Check</b>, and then select the unclogged head.</p>
	Head 2	
Restore Settings	Yes	Select <b>Yes</b> to restore all items in the <b>Printer Setup</b> menu to their default settings.
	No	

## The Maintenance Menu

The Maintenance menu can be accessed directly by pressing the  button.

Item	Parameter	Explanation	
Nozzle Check	Print	<p>A nozzle pattern will be printed. Inspect the pattern visually and perform head cleaning if you detect faint or missing colors.</p> <p> <a href="#">"Checking for clogged nozzles" on page 109</a></p>	
Cleaning			
All Nozzles	Execute (Light)/ Execute (Medium)/ Execute (Heavy)	<p>The options displayed vary with the model of printer used.</p> <p>Note the numbers of patterns that contain faint or missing colors and clean all or selected nozzles. Selecting <b>All Nozzles</b> cleans all nozzles (SC-S30600 series) or all nozzles in a selected print head (SC-S70600 series and SC-S50600 series). Choose <b>Selected Nozzles</b> to clean only the nozzles in selected arrays.</p>	
			Head 1/Head 2* <sup>1</sup>
			Head 1* <sup>1</sup>
			Head 2* <sup>1</sup>
Selected Nozzles	Execute (Light)/ Execute (Medium)/ Execute (Heavy)	<p>The level of cleaning can be selected from <b>Execute (Light)</b>, <b>Execute (Medium)</b>, and <b>Execute (Heavy)</b>. Select <b>Execute (Light)</b> first. If the problem persists after you have used <b>Execute (Light)</b>, choose <b>Execute (Medium)</b>. If the problem persists after you have used <b>Execute (Medium)</b>, choose <b>Execute (Heavy)</b>.</p> <p> <a href="#">"Head Cleaning" on page 110</a></p>	

## Using the Control Panel Menu

Item	Parameter	Explanation
Head Maintenance	Move Head	Position the print head for maintenance. Perform such maintenance as cleaning the wiper, caps, and the area around print head only after using this option to position the head for cleaning. Moving the print head manually could cause malfunction.  <a href="#">"Regular Cleaning" on page 90</a>
Waste Ink Counter	-	If you replace the waste ink bottle before being prompted by a message indicating the replacement interval of the waste ink bottle in the control panel, run the Waste Ink Counter option after replacement.
Ink Circulation* <sup>1</sup>		Run if you notice uneven colors (areas of uneven density) in print results for spot color inks.  <a href="#">"Ink Circulation and Ink Refresh" on page 111</a>
WH,MS Ink Refresh* <sup>1</sup> WH,WH Ink Refresh* <sup>1</sup>		Select this option should you notice uneven colors (areas of uneven density) once the printer is turned on following a period of disuse. <b>WH,MS Ink Refresh</b> is available when 10 color mode is selected for the SC-S70600 series, <b>WH,WH Ink Refresh</b> when 5 color mode is selected for the SC-S50600 series.  <a href="#">"Ink Circulation and Ink Refresh" on page 111</a>
Head Washing	XX/XX (nozzle array number), All Nozzles* <sup>3, *4</sup> Head1 XX/XX (nozzle array number), Head2 XX/XX (nozzle array number), Head1 All Nozzles, Head2 All Nozzles, Head1,2 All Nozzles* <sup>2</sup>	Perform when head cleaning and cleaning around the print head cannot remove nozzle clogs. Note the numbers of patterns that contain faint or missing colors, specify colors that include those numbers, and then perform head washing. Head washing requires cleaning cartridges (available separately). The required number of cleaning cartridges is provided below. <input type="checkbox"/> When specifying colors before cleaning: 2 <input type="checkbox"/> When performing All Nozzles cleaning: <input type="checkbox"/> SC-S70600 series 10 color mode: 10 <input type="checkbox"/> SC-S70600 series 8 color mode: 8 <input type="checkbox"/> SC-S50600 series 5 color mode: 10 (5) <input type="checkbox"/> SC-S50600 series 4 color mode: 8 (4) <input type="checkbox"/> SC-S30600 series: 4 The number in parentheses is the number of required cartridges when <b>Head1 All Nozzles</b> or <b>Head2 All Nozzles</b> is selected.  <a href="#">"Options and Consumable Products" on page 145</a>
Pre-Storage Maint.	WH/MS* <sup>4</sup> WH/WH* <sup>2</sup> All Nozzles	Always perform pre-storage maintenance if the printer will not be used for an extended period (and switched off.) If the storage interval is short, you can perform pre-storage maintenance for spot color ink only. Cleaning cartridges (available separately) are required for pre-storage maintenance. For details of the storage interval guidelines and number of cleaning cartridges necessary, see the following reference.  <a href="#">"Long-term Storage (Pre-storage Maintenance)" on page 112</a>



## Using the Control Panel Menu

### The Ink Level Menu

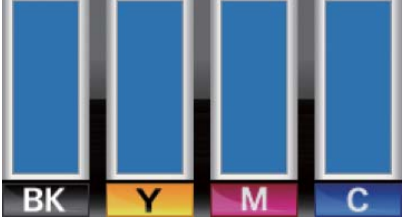
Item	Explanation
	You can see the level of each ink cartridge. When you replace an ink cartridge, the remaining ink level is automatically reset.

### The Print Logs Menu

These items are used to track consumables.

Item	Parameter	Explanation
Print Job Log Sheet	Print	You can print the job information saved in the printer (up to 10 jobs). The information includes the media and ink used in each job, making it easier to track the use of consumables.
Show Total Prints	XXXXXX m <sup>2</sup> (XXXXXX ft <sup>2</sup> )	Select Show Total Prints to view the total area of media printed (to a maximum of six figures).

### The Printer Status Menu

These items track printer use and settings.

Item	Parameter	Explanation
Print Status Sheet	Print	Print a status sheet showing current printer settings, and the status of periodical replacement parts. Use this option to view a variety of information about the printer on a single sheet and help schedule the periodic replacement of parts.
myEpsonPrinter Status	Not Started, Disabled, Enabled	You can see if myEpsonPrinter is enabled or disabled. If it is enabled, the last uploaded time is displayed. This function is not supported in some areas and some countries.
	Last Uploaded:, (Not Uploaded), MM/DD/YY HH:MM GMT	
Firmware Version	XXXXXXXX,X_XX,XXXX	View the printer Firmware Version.

### The Network Setup Menu

 indicates default settings.

Item	Parameter	Explanation
IP Address Setting		

## Using the Control Panel Menu

Item	Parameter	Explanation
Auto Panel	-	Choose whether IP addresses are obtained automatically ( <b>Auto</b> ) or manually ( <b>Panel</b> ) using DHCP. If <b>Panel</b> is selected, enter an IP address, subnet mask, and default gateway address. Contact your system administrator for detailed information.
	IP: XXX.XXX.XXX.XXX	
	SM: XXX.XXX.XXX.XXX	
	DG: XXX.XXX.XXX.XXX	
Bonjour	On	Choose whether Bonjour is used ( <b>On</b> ), or is not used ( <b>Off</b> ), in the network interface.
	Off	
Print Status Sheet	Print	Use Network Setup to print the current network status. Use this information for a complete overview of network settings.
Restore Settings	Yes	Select <b>Yes</b> to restore all items in the Network Setup menu to their default settings.
	No	

## The Preference Menu

 indicates default settings.

Item	Parameter	Explanation
Date And Time	MM/DD/YY HH:MM	Set the printer's built-in clock. The time provided by the clock is used when printing logs and status sheets.
Language	Japanese	Select the language used in the control panel display.
	English	
	French	
	Italian	
	German	
	Portuguese	
	Spanish	
	Dutch	
	Russian	
	Korean	
	Chinese	
Unit: Length	m	Choose the units of lengthh used in the control panel display and when printing test patterns.
	ft/in	
Unit: Temperature	°C	Choose the temperature units used in the control panel display.
	°F	

### Using the Control Panel Menu

Item	Parameter	Explanation
Alert Sound Setting	On	Enable ( <b>On</b> ) or disable ( <b>Off</b> ) the buzzer that sounds when an error occurs.
	Off	
Alert Lamp Setting	On	Enable ( <b>On</b> ) or disable ( <b>Off</b> ) the alert lamp that lights when an error occurs.
	Off	

---

## The Reset All Settings Menu











Parameter	Explanation
Yes	Select <b>Yes</b> to reset all settings in the Preference menu except <b>Date And Time, Language, Unit: Length, and Unit: Temperature.</b>
No	

## Problem Solver

# Problem Solver

## When a Message is Displayed



If one of the following messages is displayed, read and follow the instructions below.

Messages	What to do
Prepare empty waste ink_bottle.	The waste ink bottle is getting full. Ready a new waste ink bottle.  <a href="#">"Options and Consumable Products" on page 145</a>
Ink Cartridge Error Ink cartridge cannot be recognized. Insert again or replace ink cartridge.	<ul style="list-style-type: none"> <li><input type="checkbox"/> Remove and reinsert the ink cartridge. If the message persists, insert a new ink cartridge (do not reinsert the ink cartridge that caused the error).  <a href="#">"Replacement and Shake Methods" on page 101</a></li> <li><input type="checkbox"/> Remove and reinsert the replacement cartridge. If this message appears in the control panel again, contact your dealer or Epson Support.</li> <li><input type="checkbox"/> Condensation may have formed inside the cartridge. Leave it at room temperature for at least four hours before installing the cleaning cartridge.  <a href="#">"Notes on handling ink cartridges" on page 26</a></li> </ul>
Ink Cartridge Error Ink cartridge cannot be detected. Insert again or replace ink cartridge.	
Ink Cartridge Error Replace cleaning cartridge.	<ul style="list-style-type: none"> <li><input type="checkbox"/> Remove and reinsert the Cleaning cartridge. If the message persists, insert a new Cleaning cartridge (do not reinsert the Cleaning cartridge that caused the error).  <a href="#">"Replacement and Shake Methods" on page 101</a></li> <li><input type="checkbox"/> Condensation may have formed inside the cartridge. Leave it at room temperature for at least four hours before installing the cleaning cartridge.</li> </ul>
Ink Low	The ink is low. Ready a new ink cartridge.  <a href="#">"Options and Consumable Products" on page 145</a>
Warming Up... OK Force to start printing	One or more heaters is still being warmed to the specified temperature. To start printing without waiting for the heater to warm up, press the OK button.
Command Error Check print settings on RIP.	<ul style="list-style-type: none"> <li><input type="checkbox"/> Press  and select <b>Job Cancel</b>. Check that the installed software RIP is compatible with the printer.</li> <li><input type="checkbox"/> This error may be displayed if white ink is used with a <b>Platen Gap of 2.0</b> on a SC-S50600 series printer. Press the  button and select <b>Job Cancel</b> to stop printing, then select a <b>Platen Gap of 1.5</b> or change RIP settings before resuming printing.</li> </ul>
Unit Matching Error Check combination of Media Feeding Unit and Auto Take-up Reel Unit. Then restart printer.	The standard media feeding unit is used only with the standard auto take-up reel unit, the heavy roll media feeding unit only with the heavy roll auto take-up reel unit. If you have mismatched the feeding and take-up reel units, turn the printer off and install the correct equipment.  <a href="#">Setup Guide</a>  <a href="#">Heavy Media Roll System Setup Guide</a>
Nozzle Clog Detected Head cleaning is recommended.	Stop printing and perform head cleaning if you judge it necessary on inspecting the print results.  <a href="#">"Head Cleaning" on page 110</a>

## Problem Solver

Messages	What to do
F/W Install Error Firmware update failed. Restart the printer.	Turn the printer off, wait for a few minutes, and then turn on the printer again. Use EPSON LFP Remote Panel 2 to update the firmware again. If this message appears on the LCD panel again, contact your dealer or Epson Support.
Print head is nearing end of service life.	The print head requires periodic replacement. The current print head is nearing the end of its service life. <a href="#">☞ "Parts That Are Periodically Replaced" on page 113</a>
Auto Take-up Reel Unit stopped.	Media is not correctly attached to the auto take-up reel unit. Press the <b>II</b> button and select <b>Job Cancel</b> to cancel printing. Flip the Auto switch on the auto take-up reel unit to Off, then flip it back and reattach the media to the auto take-up reel unit. <a href="#">☞ "Media Loading" on page 62</a>
Media Size Error Load correct size media.	The media currently loaded is not the correct width. Raise the media loading lever and remove the media. The narrowest width supported by the printer is 300 mm*. Be sure the media is at least 300 mm wide. If this message is displayed even though the media is the correct width, the printer may print if <b>Off</b> is selected for <b>Media Size Check</b> . <a href="#">☞ "Printer Setup Menu" on page 124</a> * The minimum supported width for ink layering is 508 mm. Ink layering <a href="#">☞ "High Print Quality" on page 23</a>
Media Sensor Error Loaded media or print out has a problem. Refer to documentation for details.	Press <b>II</b> to clear the message from the display. If the message was displayed during auto head alignment, auto feed adjustment, or auto nozzle check, check the following. <ul style="list-style-type: none"> <li><input type="checkbox"/> Is the current media not supported? The above options do not produce the desired results with transparent or colored media, or tracing paper.</li> <li><input type="checkbox"/> Are outside light sources interfering with the process? If the printer is exposed to direct sunlight or interference from other ambient light sources, shade the printer from these sources.</li> <li><input type="checkbox"/> Is <b>2.5</b> is selected for <b>Platen Gap</b> in the setup menu? The above options are not available when <b>2.5</b> is selected for <b>Platen Gap</b>.</li> <li><input type="checkbox"/> Are the nozzles clogged (auto head alignment, auto feed adjustment)? Perform head cleaning. <a href="#">☞ "Head Cleaning" on page 110</a></li> </ul> If this error is displayed under conditions other than those listed above, confirm that the printer supports the current media.

## Problem Solver

Messages	What to do
<p>Pressure Roller Error Pressure rollers are positioned incorrectly. Release media loading lever and reposition rollers.</p>	<p>One of the following has occurred. Reposition the rollers as described in "Printable Area".</p> <ul style="list-style-type: none"> <li><input type="checkbox"/> None of the rollers is positioned inside the bounds of the black labels.</li> <li><input type="checkbox"/> Only one of the rollers is positioned inside the bounds of the black labels.</li> <li><input type="checkbox"/> The rollers at the edges of the media are not the same type. (A high pressure roller is at one edge, a low pressure roller at the other.)</li> <li><input type="checkbox"/> On is selected for Media Size Check in the printer settings menu and a roller is positioned in a black label that is not over the media.</li> <li><input type="checkbox"/> Two rollers are positioned inside the bounds of the same black label.</li> </ul> <p> <a href="#">"Printable area" on page 80</a></p>
<p>Ink Layering Error Pressure rollers are positioned incorrectly. Reposition rollers.</p>	<p>You are using the low pressure rollers. Use the high pressure rollers for ink layering. Ink layering  <a href="#">"High Print Quality" on page 23</a></p>

## When a Maintenance Call/Service Call Occurs

Error messages	What to do
<p>Maintenance Request Replace Part Soon/Replace Part Now XXXXXXXX</p>	<p>A part used in the printer is nearing the end of its service life. Contact your dealer or Epson Support and tell them the maintenance request code. You cannot clear the maintenance request until the part is replaced. A service call occurs if you continue to use the printer.</p>
<p>Call For Service XXXX Error XXXX Power off and then on. If this doesn't work, note the code and call for service.</p>	<p>A call for service occurs when:</p> <ul style="list-style-type: none"> <li><input type="checkbox"/> The power cable is not connected securely</li> <li><input type="checkbox"/> An error that cannot be cleared occurs</li> </ul> <p>When a call for service has occurred, the printer automatically stops printing. Turn off the printer, disconnect the power cable from the outlet and from the AC inlet on the printer, and then reconnect. Turn on the printer again multiple times. If the same call for service is displayed on the LCD panel, contact your dealer or EpsonSupport for assistance. Tell them the call for service code is "XXXX".</p>

### Call-for-Service Request Error Codes

The portions indicated by asterisks ("\*") vary depending on the type of error.

Carriage error	11**
Media feed error	12**, 15A*, 161*
Circuit error	00**, 13**, 1A**, 1E**, 20**, 3000, Dx**, Fx**
Ink system error	14**, 162*
Component has reached end of service life	110*, 143*
Mechanical error	15**
Heater error	19**

## Problem Solver

## Troubleshooting

### You cannot print (because the printer does not work)

#### The printer does not turn on.

■ **Is the power cable plugged into the electrical outlet or the printer?**

Make sure the power cable is securely plugged into the printer.

■ **Is there any problem with the electrical outlet?**

Make sure your outlet works by connecting the power cable for another electric product.

#### The printer is not communicating with the computer.

■ **Is the cable plugged in properly?**

Make sure the printer's interface cable is securely plugged into the correct terminal of the computer and the printer. Also, make sure the cable is not broken nor bent. If you have a spare cable, try connecting with the spare cable.

■ **Does the interface cable specification match the specifications for the computer?**

Make sure the interface cable specifications match the specifications for the printer and the computer.

 ["Specifications Table" on page 153](#)

■ **When using a USB hub, is it being used correctly?**

In the USB specification, daisy-chains of up to five USB hubs are possible. However, we recommend that you connect the printer to the first hub connected directly to the computer. Depending on the hub you are using, the operation of the printer may become unstable. If this should occur, plug the USB cable directly into your computer's USB port.

■ **Is the USB hub recognized correctly?**

Make sure the USB hub is recognized correctly on the computer. If it has, disconnect the USB hub from the computer and connect the computer directly to the printer. Ask the USB hub manufacturer about USB hub operation.

### You cannot print under the network environment.

■ **Are the network settings correct?**

Ask your network administrator for the network settings.

■ **Connect the printer directly to the computer using a USB cable, and then try to print.**

If you can print via USB, there are some problems on the network environment. Ask your system administrator, or refer to the manual for your network system. If you cannot print via USB, see the appropriate section in this User's Guide.

#### The printer has an error.

■ **Confirm if errors have occurred in the printer by checking the lights and messages on the printer's control panel.**

 ["Control panel" on page 19](#)

 ["When a Message is Displayed" on page 132](#)

### The printer sounds like it is printing, but nothing prints

#### The print head moves, but nothing prints.

■ **Confirm the printer operation.**

Print a test pattern. Test patterns can be printed without connecting the printer to a computer and hence can be used to check printer function and status.  ["Checking for clogged nozzles" on page 109](#)

Refer to the following section for information on what to do if the pattern does not print correctly.

■ **Is the message Motor Self Adjustment displayed on the control panel's screen?**

The printer adjusts the internal motor. Wait for a while without turning off the printer.

## Problem Solver

### Test Pattern Does Not Print Correctly

- Perform head cleaning.**  
 The nozzles may be clogged. Print a test pattern again after performing head cleaning.  
 ↗ "Head Cleaning" on page 110

- Has the printer been left unused for a long time?**  
 If the printer has not been used for a long time, the nozzles may have dried up and have been clogged. Steps to take when the printer has not been used for a long time ↗ "Notes when not using the printer" on page 25

---

### The prints are not what you expected

#### Print quality is poor, uneven, too light, or too dark.

- Are the print head nozzles clogged?**  
 If the nozzles are clogged, specific nozzles do not fire ink and the print quality declines. Try printing a test pattern.  
 ↗ "Checking for clogged nozzles" on page 109

- Was Head Alignment performed?**  
 Select Head Alignment to realign the print head when print results seem grainy or out of focus.  
 ↗ "Head Alignment (Manual Adjustment)" on page 75

- Have you tried Feed Adjustment?**  
 Large discrepancies in the feed amount cause banding (horizontal banding, lines, or strips of uneven color). Perform Feed Adjustment according to the media used.  
 ↗ "Feed Adjustment" on page 71

- Are you using a genuine Epson ink cartridge?**  
 This printer is developed for use with Epson ink cartridges. If you use non-Epson ink cartridges, printouts may be faint, or the color of the printed image may be changed because the remaining ink level is not correctly detected. Be sure to use the correct ink cartridge.

- Are you using an old ink cartridge?**  
 The print quality declines when an old ink cartridge is used. Replace the old ink cartridge with a new one. Use all the ink in the cartridge before the date printed on the package or within six months of opening, whichever is sooner.

- Are the heaters at the correct temperature?**  
 Raise the temperature if the print results are blurred or smudged or the ink clots. Note, however, that raising the temperature too high can cause the media to shrink, wrinkle, or deteriorate.  
  
 In addition, the heaters may require some time to reach the desired temperature if the ambient temperature is low. The heaters may also not have the desired effect after reaching the selected temperature if the media is too cold. Allow the media to warm to room temperature before use.

- Are media settings correct?**  
 Confirm that the media settings in the software RIP or on the printer match the media actually in use.

- Is Data Width selected for Head Movement?**  
 Selecting **Data Width** for **Head Movement** in the setup menu increases print speed but may slightly reduce print quality. For better quality results, select **Printer Full Width** for **Head Movement**. ↗ "Printer Setup Menu" on page 124

- Have you compared the printing result with the image on the display monitor?**  
 Since monitors and printers produce colors differently, printed colors will not always match on-screen colors perfectly.

- Was a printer cover opened during printing?**  
 Opening covers during printing causes the print head to stop abruptly, resulting in uneven colors. Do not open the covers while printing is in progress.

- Is Ink Low displayed on the control panel's screen?**  
 The print quality may decline when the ink is low. We recommend replacing the ink cartridge with a new one. If there is a difference in color after replacing the ink cartridge, try performing head cleaning a few times.



## Problem Solver

### ■ Are you printing with white or metallic silver ink?

Components may have sedimented from (settled to the bottom of) the white or metallic silver ink. Shake the cartridge thoroughly and perform **Ink Circulation** several times.

If the problem persists, select **WH,MS Ink Refresh** or **WH,WH Ink Refresh**.

Shaking ink cartridges  ["Replacement and Shake Methods" on page 101](#)

 ["Ink Circulation and Ink Refresh" on page 111](#)

## The print is not positioned properly on the media.

### ■ Is the media loaded correctly and are the margins correct?

If the media is not loaded correctly, the results may be off center or part of the data may not be printed. You should also check whether the correct options are selected for **Side Margin** and **Print Start Position** in the setup menu.

 ["Loading Media \(SC-S70600 series, SC-S50600 series\)" on page 36](#)

 ["Loading Media \(SC-S30600 series\)" on page 48](#)

 ["Printer Setup Menu" on page 124](#)

### ■ Is the media skewed?

If **Off** is selected for **Media Skew Check** in the setup menu, printing will continue when the media is skewed and data will appear outside the print area. Set **Media Skew Check** to **On** in the Menu.

 ["Printer Setup Menu" on page 124](#)

### ■ Is the media wide enough for the print data?

Although printing normally stops if the print image is wider than the media, data will be printed beyond the edges of the media if **Off** is selected for **Media Size Check** in the setup menu. Choose **On** for **Media Size Check** in the setup menu.

 ["Printer Setup Menu" on page 124](#)

## Vertical ruled lines are misaligned.

### ■ Is the print head misaligned? (in bidirectional printing)

With bidirectional printing, the print head prints while moving left and right. If the print head is misaligned, ruled lines may be misaligned accordingly. If vertical ruled lines are misaligned with bidirectional printing, perform Head Alignment.

 ["Head Alignment \(Manual Adjustment\)" on page 75](#)

## The printed surface is scuffed or soiled.

### ■ Is the media too thick or too thin?

Check media specifications to confirm that it is compatible with the printer. If you are using a software RIP, contact the manufacturer for information on the settings and media that can be used.

### ■ Is the media wavy?

Certain types of media may develop waves under some conditions (humidity and temperature) while installed in the printer. If a wave has developed, press the **▼** button in the control panel to feed the media and avoid the affected area. We recommend that you lower the temperature and humidity to prevent waves developing.

### ■ Is the media creased or folded?

Media that is creased or folded may rise from the platen and contact the print head, resulting in smudges or uneven colors.

### ■ Are the wiper, caps, or print head stained?

Ink clots, lint or dust around the wiper, caps, or print head may result in stains caused by ink drops. Clean the affected area.

 ["Regular Cleaning" on page 90](#)

### ■ Is the print head striking the printed surface?

Smear caused by the print head striking the media can be prevented by adjusting the **Platen Gap** to suit the media.

It may also be prevented by choosing a high value for **Media Tension**.

 ["Platen Gap" on page 72](#)

 ["Media Tension" on page 74](#)

## Problem Solver

### Areas secured by pressure rollers are stained.

- **Are the pressure rollers stained?**  
Clean the pressure rollers.  
 ["Cleaning Inside the Printer" on page 96](#)

### Nozzle clogs cannot be cleared



- **Is cleaning being performed regularly?**  
If lint or dust adheres to the area around the print head, caps, wiper, or flushing pad, nozzle clogs may occur during printing. Moreover, if the lint or dust is left adhered, nozzle clogs cannot be cleared even after repeated head cleaning. Clean the affected area.  
 ["Regular Cleaning" on page 90](#)

### Ink drops



- **Is media being handled appropriately?**  
If the following points are not observed when handling media, small amounts of dust and lint may stick to the media surface and cause ink drops in the print results.
  - Do not place exposed media directly on the floor.  
Media should be rewound and inserted in its original packaging for storage.
  - Do not carry media with the media surface pressed against clothing.  
Handle media in its individual packaging until just before setting the media in the printer.

### Horizontal lines or strips of uneven color (banding)

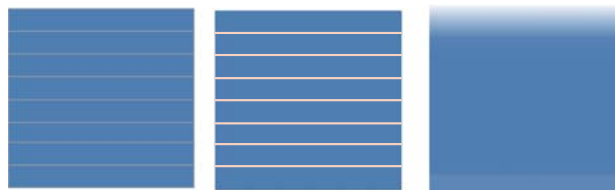

#### Multiple causes are possible.

Perform the following sequence until the print results have improved.

Before starting work, always perform a nozzle check and head alignment (manual adjustment). If nozzles are clogged or the head is misaligned, no measures will result in improvements.

 ["Checking for clogged nozzles" on page 109](#)

 ["Head Alignment \(Manual Adjustment\)" on page 75](#)

1

Check the attachment of the media holding plates

If a media holding plate is not installed correctly, media feeding may be disturbed. See the following reference and reattach the media holding plates.

 ["Loading and Exchanging Media" on page 32](#)

If installing the media holding plate correctly still does not resolve the problem, perform the following measure.

2

Resolving ink sedimentation

Sedimentation (components settling to the bottom of the liquid) may occur inside the printer. Perform head cleaning using the following steps.

- Select **All Nozzles - Head1/Head2** (SC-S70600 series and SC-S50600 series only) - **Execute (Heavy)**.
- Repeat the previous step.

 ["Head Cleaning" on page 110](#)

## Problem Solver

If performing head cleaning twice does not resolve the problem, perform the following measure.

### 3 Feed Adjustment

Feed adjustment may be required independently depending on the media used. If the roll width is different, independent adjustment is required even with the same media. Perform feed adjustment as described below.

- Print the Adjustment Pattern using **Manual - 500mm Pattern**.
- When entering an adjustment value, use the value recorded for the distance between the + symbols in the center only.

[🔗 “Feed Adjustment \(Manual Feed Adjustment\)” on page 77](#)

If feed adjustment does not resolve the problem, perform the following measure.

### 4 Resolving ink drying time differences

During bidirectional printing, print head movement may cause an ink drying time difference. Firstly, perform unidirectional printing from RIP. If this improves the print results, change the **Heater Temperature** or **Drying Time Per Pass**, and adjust so that stripes and unevenness are improved during bidirectional printing.

[🔗 “The Media Setup Menu” on page 120](#)

First, configure **Heater Temperature** as described below.

- 1) Configure temperature settings for the pre-, platen, and after heaters to a temperature higher than the normal setting temporarily.
- 2) Perform bidirectional printing and check if the print results have improved.
- 3) If the problem is not resolved, set temperature settings for the pre-, platen, and after heaters slightly lower.

Repeat Steps 2 and 3 until print results are improved.

If changing the **Heater Temperature** does not resolve the problem, adjust **Drying Time Per Pass** in the following manner.

- 1) Set the setting value to **0.1**.
- 2) Perform bidirectional printing and check if the print results have improved.
- 3) If the problem is not resolved, raise the setting value further.

Repeat Steps 2 and 3 until print results are improved.

If the measures above do not resolve the problem, perform the following measure.

### 5 Checking the microweave (M/W) setting

The microweave (M/W) setting may be inappropriate.

Refer to the microweave (M/W) setting and banding association table researched by Epson, change the settings according to the media being used, and then check for improvement.

Microweave (M/W) setting and banding association table researched by Epson [🔗 “Microweave \(M/W\) setting and banding association table” on page 151](#)

## Stains Due to Head Striking



**The media and print head are contacting during printing.**

Perform the following sequence until the print results have improved.

## Problem Solver

### 1 Cut sections of media with wrinkles or waviness

If media is stored inappropriately or left loaded in the printer, wrinkles and waviness may occur. If media is used in this state, the print head and the raised surface of the media may contact and cause staining. Cut sections with wrinkles or waviness before using media.

Furthermore, store media as described in the manual accompanying the printer and load media in the printer just before printing.

If the problem is not resolved even when printing on sections without wrinkles or waviness, perform the following measure.

### 2 Loading the media in the printer correctly and configuring the media settings appropriately

If the media loading method, heating temperature, tension, suction and other settings are inappropriate, wrinkles and waviness occur on the media. Make sure the loading method and settings are correct.

 [“Loading and Exchanging Media” on page 32](#)

 [“Recommended values for leading media types” on page 70](#)

If the measures above do not resolve the problem, perform the following measure.

### 3 Adjusting the **Heater Temperature**

The heater temperature setting may be too high.

Configure **Heater Temperature** as described below.

- 1) Configure the temperature setting of each heater to the following temperatures temporarily.

Pre-heater: **30**, platen heater: **30**, after heater: **40**

 [“The Media Setup Menu” on page 120](#)

- 2) Print and see if waviness has improved.

If the waviness of the media improved, the heater temperature setting was too high.

- 3) While gradually raising the pre-heater, platen heater, and after heater temperature settings, repeat test printing until the optimal state is reached.

If the problem is not resolved after performing 1), return **Heater Temperature** to the original setting, and then perform the following measure.

### 4 Adjusting **Media Tension**

Adjustment of **Media Tension** differs by the media used.

**When using vinyl, transparent film or canvas**  
Use the following procedure to adjust **Media Tension**.

- 1) Set the setting value to **2** temporarily.

 [“The Media Setup Menu” on page 120](#)

- 2) Print and check if the print results have improved.
- 3) If the problem is not resolved, raise the setting value one level.

Repeat Steps 2 and 3 until print results are improved in the range up to a setting value of **5**.

- If you are using SC-S70600 series or SC-S50600 series and adjusting the **Media Tension** does not resolve the problem, perform the following measure.

- 1) Set **Feed Speed** to **1**.

 [“The Media Setup Menu” on page 120](#)

- 2) Set the **Media Tension** setting value to **2** temporarily.
- 3) Print and check if the print results have improved.

## Problem Solver

- 4) If the problem is not resolved, raise the setting value one level.

Repeat Steps 3 and 4 until print results are improved in the range up to a setting value of 5.

If the measures above do not resolve the problem, return the **Media Tension** setting to default and perform the following measure.

- On the SC-S30600 series, if adjusting **Media Tension** does not resolve the problem, return the **Media Tension** setting to default and perform the following measure.

### When using banners

Find the procedure for your printer model below and adjust **Media Tension**.

- When using the SC-S70600 series or SC-S50600 series

- 1) Set the setting value to **2** temporarily.

 [“The Media Setup Menu” on page 120](#)

- 2) Print and check if the print results have improved.
- 3) If the problem is not resolved, raise the setting value one level.

Repeat Steps 2 and 3 until print results are improved in the range up to a setting value of 5.

If changing **Media Tension** does not resolve the problem, return the **Media Tension** setting to default and perform the following measure.

- When using SC-S30600 series

- 1) Set the setting value to **40**.

 [“The Media Setup Menu” on page 120](#)

- 2) Print and check if the print results have improved.

If changing **Media Tension** does not resolve the problem, return the **Media Tension** setting to default and perform the following measure.

## 5

Checking that the media is loaded correctly in the auto take-up reel unit

If the method to attach the media to the take up roll core or the method to attach the counterweights is inappropriate, media may move around during take-up, which may cause wrinkles and raised sections.

Check if the following actions were performed correctly: attachment of media on the auto take-up reel unit and attachment of counterweights.

 [“Media Loading” on page 62](#)

 [“Counterweight Loading” on page 67](#)

If the measures above do not resolve the problem, perform the following measure.

## 6

Adjusting **Media Suction**

Media may rise because the media suction is weak.

Adjust **Media Suction** in the following manner.

- 1) Set the setting value to **10** temporarily.

 [“The Media Setup Menu” on page 120](#)

- 2) Print and check if creasing is improved.

If the creasing of media has improved, media suction was too low.

- 3) While gradually lowering the **Media Suction** setting, repeat test printing until the optimal state is reached.

## Problem Solver

### Media

#### Media Is Creased

- **Are the Media Tension and Feed Speed options in the setup menu correct for the current media?**

If these options are not correctly adjusted for the current media, the media may be creased or torn during printing.

🔗 ["Media Tension" on page 74](#)

🔗 ["Feed Speed" on page 74](#)

- **Are the heaters set too high?**

Adjust heater temperature to suit the media.

- **Try selecting Off for Tension Measurement in the setup menus.**

Automatic tensioning may fail to maintain some types of media at the appropriate tension, resulting in excessive slack or other tensioning problems that interfere with printing.

🔗 ["Tension Measurement" on page 74](#)

#### Media Jams

- **Is the media creased or folded?**

Media with a strong curl or that is folded back on its leading edge or creased may cause jams or other media feed problems. Do not use media affected by these types of problems.

- **Is the media too thick or too thin?**

Check the media specifications to determine whether it can be used in the printer. If you are using a software RIP, contact the manufacturer for information on the settings and media that can be used.

- **Is Media Suction set too high?**

Reduce Media Suction. 🔗 ["Media Suction" on page 73](#)

#### Printing does not stop when the roll ends

- **Is Off selected for Tension Measurement?** Periodically is recommended in most circumstances.

🔗 ["Tension Measurement" on page 74](#)

### Removing Jammed Media

Follow the steps below to remove jammed media.



**Caution:**

Be careful not to trap your hands or fingers when opening or closing the front cover. Failure to observe this precaution could result in injury.

1

Open the front cover.

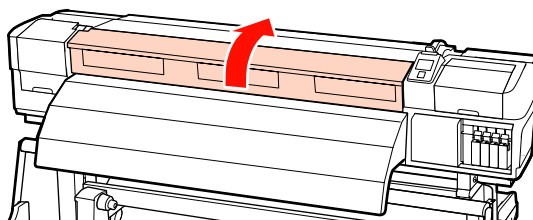

2

Turn off the printer.

If a message is displayed and the printer will not turn off, unplug both power cables.

3

Remove the media holding plates, if installed.

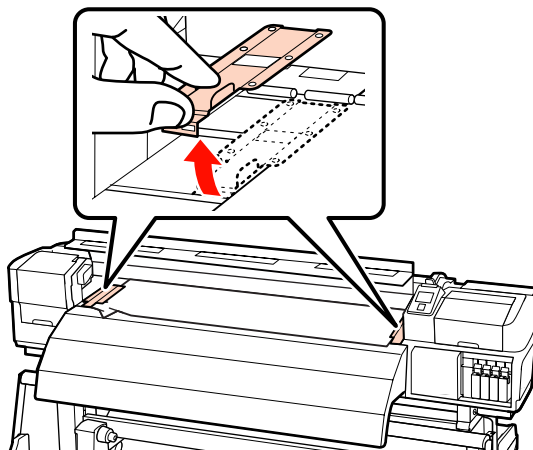

**Important:**

Cease use of the printer if the media holding plates are deformed. Continued use could damage the pressure rollers or print head.

Contact your dealer or Epson Support.

**Problem Solver**

- 4** If the print head is over the media, move it away from the jam.

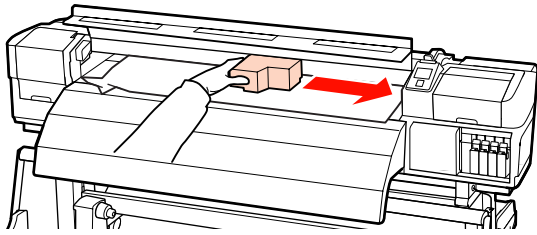

**! Important:**  
 Move the print head only after removing the media holding plates. Contact with deformed media holding plates could damage the print head.

- 5** Raise the media loading lever.



- 6** Pull the media to the cutter groove and use a cutter to remove torn or creased portions.

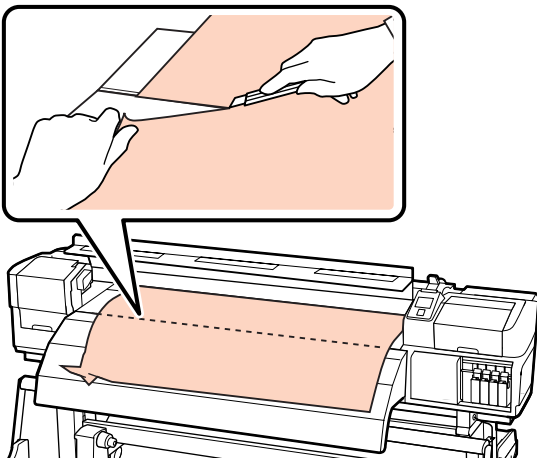

- 7** Manually rewind the cut media.

- 8** Remove any media that remains inside the printer.

- 9** Turn the printer on.

**! Important:**  
 If the printer is left off for an extended period, the print head will be left uncapped and dry out, and will not print properly when printing resumes.  
 Turning the printer on automatically caps the print head.

Reload the media and resume printing.

[“Loading Media \(SC-S70600 series, SC-S50600 series\)” on page 36](#)

[“Loading Media \(SC-S30600 series\)” on page 48](#)

**Others**

**Heaters Turn off or the Optional Additional Print Drying System Stops**

■ The pre-, platen, and after heaters will turn off if no print job is received for some time and no error occurs. The time before the heaters turn off automatically can be selected using the **Heat Off Timer** option in the setup menu. [“Printer Setup Menu” on page 124](#)  
 The heaters will be reactivated when a print job is received, the media loading lever is used, or another operation involving printer hardware is performed.  
 An additional print drying system is supplied with the SC-S50600 series.

**The control panel display keeps turning off.**

■ **Is the printer in sleep mode?**  
 The printer enters sleep mode when the **Heat Off Timer** expires and the heaters turn off. The time before the heaters turn off can be selected in the Printer Setup menu.  
[“Printer Setup Menu” on page 124](#)  
 The heaters will be reactivated and sleep mode will end when a print job is received, the media loading lever is used, or another operation involving printer hardware is performed.

## Problem Solver

### The red light is on inside the printer.



**This is not a failure.**

The red light is a light inside the printer.



## Appendix

---

# Appendix

---

## Options and Consumable Products

The following options and consumable products are available for use with this printer. (as of July 2013)

For the latest information, see the Epson Web site.

### Ink cartridges\*

Printer model	Product	Part number	
SC-S70600	Ink cartridges	Black	T7131
		Cyan	T7132
		Magenta	T7133
		Yellow	T7134
		Light Cyan	T7135
		Light Magenta	T7136
		Light Black	T7137
		Orange	T7138
		White	T713A
		Metallic Silver	T713B
SC-S70610	Ink cartridges	Black	T7141
		Cyan	T7142
		Magenta	T7143
		Yellow	T7144
		Light Cyan	T7145
		Light Magenta	T7146
		Light Black	T7147
		Orange	T7148
		White	T714A
		Metallic Silver	T714B

## Appendix

Printer model	Product	Part number	
SC-S70670	Ink cartridges	Black	T7151
		Cyan	T7152
		Magenta	T7153
		Yellow	T7154
		Light Cyan	T7155
		Light Magenta	T7156
		Light Black	T7157
		Orange	T7158
		White	T715A
		Metallic Silver	T715B
SC-S70680	Ink cartridges	Black	T7161
		Cyan	T7162
		Magenta	T7163
		Yellow	T7164
		Light Cyan	T7165
		Light Magenta	T7166
		Light Black	T7167
		Orange	T7168
		White	T716A
		Metallic Silver	T716B
SC-S50600	Ink cartridges	Black	T6871
		Cyan	T6872
		Magenta	T6873
		Yellow	T6874
		White	T713A
SC-S50610	Ink cartridges	Black	T6881
		Cyan	T6882
		Magenta	T6883
		Yellow	T6884
		White	T714A

## Appendix



Printer model	Product		Part number
SC-S50670	Ink cartridges	Black	T6891
		Cyan	T6892
		Magenta	T6893
		Yellow	T6894
		White	T715A
SC-S50680	Ink cartridges	Black	T6901
		Cyan	T6902
		Magenta	T6903
		Yellow	T6904
		White	T716A
SC-S30600	Ink cartridges	Black	T6871
		Cyan	T6872
		Magenta	T6873
		Yellow	T6874
SC-S30610	Ink cartridges	Black	T6881
		Cyan	T6882
		Magenta	T6883
		Yellow	T6884
SC-S30670	Ink cartridges	Black	T6891
		Cyan	T6892
		Magenta	T6893
		Yellow	T6894
SC-S30680	Ink cartridges	Black	T6901
		Cyan	T6902
		Magenta	T6903
		Yellow	T6904

\* Epson recommends the use of genuine Epson ink cartridges. Epson cannot guarantee the quality or reliability of nongenuine ink. The use of non-genuine ink may cause damage that is not covered by Epson's warranties, and under certain circumstances, may cause erratic printer behavior. Information about non-genuine ink levels may not be displayed, and use of non-genuine ink is recorded for possible use in service support.

 ["Replacement and Shake Methods" on page 101](#)

## Appendix

### Others

Product	Part number	Explanation
Cleaning cartridge	T6990	Use for print head washing, pre-storage maintenance, and so on.
Maintenance Kit	T7241	Contains the cleaning sticks, gloves, wiper, wiper cleaner, flushing pad and cleaning wiper required for printer maintenance.  <a href="#">"Regular Cleaning" on page 90</a>
Ink Cleaner	T6993	Use when wiping ink stains.  <a href="#">"Regular Cleaning" on page 90</a>
Waste Ink Bottle	T7240	Identical to the waste ink bottle supplied with the printer.
Cleaning Wiper	S090012	Identical to the maintenance kit items supplied with the printer.
Cleaning Stick	S090013	
Clean Room Wiper*1	S090016	
Flushing Pad*2	S090014	
Wiper Kit*2	S090015	Wiper and wiper cleaner set identical to items supplied with the printer.
Media Holding Plate	C12C890891	Identical to the media holding plate supplied with the printer.
Additional Print Drying System	C12C890751	Uses a fan to blow air over the media and assist drying. Supplied with SC-S50600 series printers.  <a href="#">"The Media Setup Menu" on page 120</a>
Heavy Roll Media System	C12C890761	A media feeding unit and auto take-up reel for heavy rolls (up to 80 kg).

\*1 Not available for purchase in some countries and regions. We recommend BEMCOT M-3II by Asahi Kasei Corporation when purchasing commercial products.

\*2 Not available for purchase in some countries and regions.

## Appendix

## Supported Media

The following media can be used with the printer.

Print quality is greatly affected by the type and quality of media used. Choose a media suited to the task at hand. For information on use, refer to the documentation supplied with the media or contact the manufacturer. We recommend that you print a test run and check the results before purchasing media in large quantities.



**Important:**

*Do not use media that is wrinkled, scuffed, torn, or dirty.*

**Note:**

*Ink layering is not available with some media types, such as banner and canvas.*

### Standard Roll Media System

Roll core size	2 or 3 inch
Roll outer diameter	Up to 250mm
Media width	300* to 1626 mm (64 inch)
Media thickness	Up to 1 mm
Roll weight	Up to 40 kg

\* Minimum media width for ink layering is 508 mm.

Ink layering ["High Print Quality" on page 23](#)

### Heavy Roll Media System

Roll core size	2 or 3 inch
Roll outer diameter	Up to 300 mm
Media width	300* to 1626 mm (64 inch)
Media thickness	Up to 1 mm
Roll weight	Up to 80 kg

\* Minimum media width for ink layering is 508 mm.

Ink layering ["High Print Quality" on page 23](#)

## Moving and Transporting the Printer

This section describes how to move and transport the product.

### Moving the Printer

This section assumes that the product is being moved to another location on the same floor without traversing stairs, ramps, or lifts. See below for information on moving the printer between floors or to another building.

["Transport" on page 150](#)



**Caution:**

*Do not tilt the product more than 10 degrees forward or back while moving it. Failure to observe this precaution could result in the printer falling over, causing accidents.*



**Important:**

*Do not remove the ink cartridges. Failure to observe this precaution could cause the print head nozzles to dry out.*

### Getting Ready

- 1 Confirm that the printer is off.
- 2 Remove the waste ink bottle.  
 ["Replacing the Waste Ink Bottle" on page 103](#)
- 3 Disconnect the power cords and all other cables.
- 4 Remove media from the media feeding unit and auto take-up reel unit.

## Appendix

- 5** Unlock the stand.

Release the caster locks on the left and right legs and fully raise the adjusters.

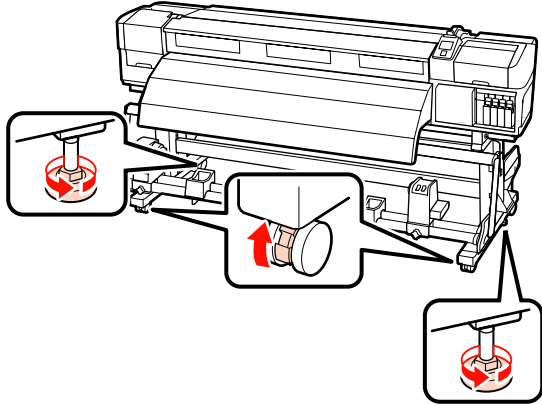

- 6** Move the printer.

**!** **Important:**  
 Use the casters on the dedicated printer stand to move the printer indoors a short distance over a level floor. They can not be used for transport.

## Post-Move Setup

After moving the printer, follow the steps below to ready it for use.

- 1** Check that the new location is appropriate.  
 ↗ [Setup Guide](#)
- 2** Plug in the power cables and turn the printer on.  
 ↗ [Setup Guide](#)
- 3** Perform a nozzle check to check for clogged nozzles.  
 ↗ [“Checking for clogged nozzles” on page 109](#)
- 4** Perform Head Alignment and check print quality.  
 ↗ [“Head Alignment” on page 72](#)

## Transport

Before transporting the printer, contact your dealer or Epson Support.

Appendix

# Microweave (M/W) setting and banding association table

Before looking at the table, check the following illustrations.

\* Speed is media feed speed (ips).

Stripe banding example

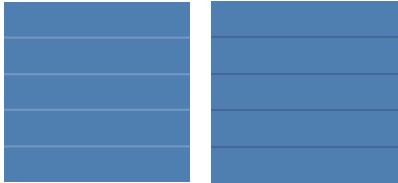

Tint unevenness example



## SC-S70600 series

Resolution (dpi)	Number of passes	M/W level	Speed *	Result	Recommendation
Banner					
720×720	6	1	2.9	Stripe banding less likely	✓
		2		Tint unevenness less likely	
Vinyl					
720×720	8	3	2.9	Stripe banding less likely	
		4		Tint unevenness less likely, but stripe banding more likely	
		5	1	Stripe banding less likely	✓
		6		Tint unevenness less likely, but stripe banding more likely	
All media (Including Banner/Vinyl)					
720×1440	12	3	1	Stripe banding less likely	✓
		4		Tint unevenness less likely	

## SC-S50600 series

Resolution (dpi)	Number of passes	M/W level	Speed *	Result	Recommendation
Banner					

**Appendix**

Resolution (dpi)	Number of passes	M/W level	Speed *	Result	Recommendation
720×720	4	1	2.9	Stripe banding less likely	
		2		Tint unevenness less likely, but stripe banding more likely	
		3		Stripe banding less likely	✓
		4		Tint unevenness less likely, but stripe banding more likely	
Vinyl					
720×1440	6	0	2.9	Stripe banding less likely	✓
		1		Tint unevenness less likely, but stripe banding more likely	
All media (Including Banner/Vinyl)					
720×1440	8	2	2.9	Stripe banding less likely	
		3	1	Tint unevenness less likely	✓

**SC-S30600 series**

Resolution (dpi)	Number of passes	M/W level	Speed *	Result	Recommendation
Banner					
720×720	4	2	1	Tint unevenness less likely	
		3		Stripe banding less likely	✓
Vinyl					
720×1440	6	0	1	Tint unevenness less likely	
		1		Stripe banding less likely	✓
All media (Including Banner/Vinyl)					
720×1440	8	3	1	Tint unevenness less likely	
		4		Stripe banding less likely	✓



## Appendix

# System Requirements

Consult the documentation for your software RIP.

## Specifications Table

Printer Specifications	
Printing method	On-demand ink jet
Nozzle configuration	<p>SC-S70600 series: 360 nozzles × 2 rows × 10 colors (Metallic Silver, Light Black, Black, Cyan, Magenta, Yellow, Orange, Light Cyan, Light Magenta, White)</p> <p>SC-S50600 series: 360 nozzles × 2 × 2 rows × 5 colors (White, Black, Cyan, Magenta, Yellow)</p> <p>SC-S30600 series: 360 nozzles × 2 rows × 4 colors (Black, Cyan, Magenta, Yellow)</p>
Resolution (maximum)	1440 × 1440 dpi
Control code	ESC/P raster (undisclosed command)
Media feed method	Friction feed
Built-in memory	512 MB for Main 128 MB for Network
Interface	Hi-Speed USB-Compatible with the USB 2.0 Specification. 100Base-TX/1000Base-T*1
Rated voltage (#1, #2, #3*2)	AC 100 to 120V AC 200 to 240V
Rated frequency (#1, #2, #3*2)	50 to 60Hz
Rated current (#1, #2)	10A (AC 100 to 120V) 5A (AC 200 to 240V)
Rated current (#3 <sup>2</sup> )	1A (AC 100 to 120V) 0.5A (AC 200 to 240V)

Printer Specifications	
Power consumption	<p>SC-S70600 series (total for numbers 1 and 2) Printing: Approx. 800 W Ready mode: Approx. 580 W Sleep mode: Approx. 12 W Power off: 0.6 W or less</p>
	<p>SC-S50600 series (total for numbers 1, 2, and 3*2) Printing: Approx. 895 W Ready mode: Approx. 775 W Sleep mode: Approx. 14 W Power off: 0.9 W or less</p>
	<p>SC-S30600 series (total for numbers 1 and 2) Printing: Approx. 650 W Ready mode: Approx. 520 W Sleep mode: Approx. 10 W Power off: 0.6 W or less</p>
Temperature	<p>Operating: 15 to 35 °C/59 to 95 °F (20 to 32 °C/68 to 90 °F recommended)</p> <p>Storage: -20 to 40°C (-4 to 104 °F) (within a month at 40°C (104 °F))</p>
Humidity	<p>Operating: 20 to 80% (40 to 60% recommended) (without condensation)</p> <p>Storage: 5 to 85% (without condensation)</p>

**Appendix**

Printer Specifications	
<p>Operation temperature and humidity range</p>	
Dimension	<p>Storage (minimum) dimensions: 2620 (W) × 963 (D) × 1311 (H) mm</p> <p>Maximum dimensions: 2620 (W) × 1259 (D) × 1650 (H) mm</p>
Weight*3	<p>SC-S70600 series: Approx. 229 kg</p> <p>SC-S50600 series: Approx. 238 kg</p> <p>SC-S30600 series: Approx. 219 kg</p>

\*1 Use a shielded twisted pair cable (category 5 or better).  
 \*2 For additional print drying system supplied with SC-S50600 series  
 \*3 Supplied media system installed; ink cartridges not included

Ink Specifications	
Type	Special ink cartridges
Pigment ink	<p>SC-S70600 series: Metallic Silver, Light Black, Black, Cyan, Magenta, Yellow, Orange, Light Cyan, Light Magenta, White</p> <p>SC-S50600 series: White, Black, Cyan, Magenta, Yellow</p> <p>SC-S30600 series: Black, Cyan, Magenta, Yellow</p>
Use by date	See the date printed on the package (at normal temperature)
Print quality guarantee expiry	Six months (from date package containing ink cartridge is opened)
Storage temperature	<p>Uninstalled: -20 to 40°C (within a month at 40°C)</p> <p>Installed: -10 to 40°C (maximum four days at 40°C)</p> <p>Transporting: -20 to 60°C (within a month at 40°C, within 72 hours at 60°C)</p>
Cartridge dimensions	(W) 40 x (D) 305 x (H) 110 mm
Capacity	<p>White: 600 ml</p> <p>Metallic Silver: 350 ml</p> <p>Other colors: 700 ml</p>

 **Important:**  
Do not refill the ink.

**Standards and Approvals**

Safety	UL 60950-1	
	CSA C22.2 No.60950-1	
	Low Voltage Directive 2006/95/EC	EN 60950-1

**Appendix**

EMC	FCC part 15 subpart B Class A	
	CAN/CSA-CEI/IEC CISPR 22 Class A	
	AS/NZS CISPR 22 Class A	
	EMC Directive 2004/108/EC	EN 55022 Class A
		EN 55024
EN 61000-3-2		
EN 61000-3-3		



**Warning:**

*This is a class A product. In a domestic environment this product may cause radio interference in which case the user may be required to take adequate measures.*

## Where To Get Help

---

# Where To Get Help

---

## Technical Support Web Site

Epson's Technical Support Web Site provides help with problems that cannot be solved using the troubleshooting information in your product documentation. If you have a Web browser and can connect to the Internet, access the site at:

<http://support.epson.net/>

If you need the latest drivers, FAQs, manuals, or other downloadables, access the site at:

<http://www.epson.com>

Then, select the support section of your local Epson Web site.

## Contacting Epson Support

---

### Before Contacting Epson

If your Epson product is not operating properly and you cannot solve the problem using the troubleshooting information in your product documentation, contact Epson support services for assistance. If Epson support for your area is not listed below, contact the dealer where you purchased your product.

Epson support will be able to help you much more quickly if you give them the following information:

- Product serial number  
(The serial number label is usually on the back of the product.)
- Product model
- Product software version  
(Click **About**, **Version Info**, or similar button in the product software.)
- Brand and model of your computer
- Your computer operating system name and version
- Names and versions of the software applications you normally use with your product

## Where To Get Help

### Help for Users in North America

Epson provides the technical support services listed below.

#### Internet Support

Visit Epson's support website at <http://epson.com/support> and select your product for solutions to common problems. You can download drivers and documentation, get FAQs and troubleshooting advice, or e-mail Epson with your questions.

#### Speak to a Support Representative

Dial: (562) 276-1300 (U.S.), or (905) 709-9475 (Canada), 6 am to 6 pm, Pacific Time, Monday through Friday. Days and hours of support are subject to change without notice.

Before you call Epson for support, please have the following information ready:

- Product name
- Product serial number
- Proof of purchase (such as a store receipt) and date of purchase
- Computer configuration
- Description of the problem



**Important:**

*For help using any other software on your system, see the documentation for that software for technical support information.*

#### Purchase Supplies and Accessories

You can purchase genuine Epson ink cartridges, ribbon cartridges, paper, and accessories from an Epson authorized reseller. To find the nearest reseller, call 800-GO-EPSON (800-463-7766). Or you can purchase online at <http://www.epsonstore.com> (U.S. sales) or <http://www.epson.ca> (Canadian sales).

### Help for Users in Europe

Check your **Pan-European Warranty Document** for information on how to contact Epson support.

### Help for Users in Australia

Epson Australia wishes to provide you with a high level of customer service. In addition to your product documentation, we provide the following sources for obtaining information:

#### Your Dealer

Don't forget that your dealer can often help identify and resolve problems. The dealer should always be the first call for advice on problems; they can often solve problems quickly and easily as well as give advice on the next step to take.

#### Internet URL

<http://www.epson.com.au>

Access the Epson Australia World Wide Web pages. Worth taking your modem here for the occasional surf! The site provides a download area for drivers, Epson contact points, new product information and technical support (e-mail).

#### Epson Helpdesk

Epson Helpdesk is provided as a final backup to make sure our clients have access to advice. Operators on the Helpdesk can aid you in installing, configuring and operating your Epson product. Our Pre-sales Helpdesk staff can provide literature on new Epson products and advise where the nearest dealer or service agent is located. Many types of queries are answered here.

The Helpdesk numbers are:

Phone: 1300 361 054

Fax: (02) 8899 3789

## Where To Get Help

We encourage you to have all the relevant information on hand when you ring. The more information you prepare, the faster we can help solve the problem. This information includes your Epson product documentation, type of computer, operating system, application programs, and any information you feel is required.

---

### Help for Users in Singapore

Sources of information, support, and services available from Epson Singapore are:

#### World Wide Web

(<http://www.epson.com.sg>)

Information on product specifications, drivers for download, Frequently Asked Questions (FAQ), Sales Enquiries, and Technical Support via e-mail are available.

#### Epson HelpDesk

(Phone: (65) 65863111)

Our HelpDesk team can help you with the following over the phone:

- Sales enquiries and product information
- Product usage questions or problems
- Enquiries on repair service and warranty

---

### Help for Users in Thailand

Contacts for information, support, and services are:

#### World Wide Web

(<http://www.epson.co.th>)

Information on product specifications, drivers for download, Frequently Asked Questions (FAQ), and e-mail are available.

#### Epson Hotline

(Phone: (66)2685-9899)

Our Hotline team can help you with the following over the phone:

- Sales enquiries and product information
- Product usage questions or problems
- Enquiries on repair service and warranty

---

### Help for Users in Vietnam

Contacts for information, support, and services are:

Epson Hotline (Phone): 84-8-823-9239

Service Center: 80 Truong Dinh Street,  
District 1, Hochiminh City  
Vietnam

---

### Help for Users in Indonesia

Contacts for information, support, and services are:

#### World Wide Web

(<http://www.epson.co.id>)

- Information on product specifications, drivers for download
- Frequently Asked Questions (FAQ), Sales Enquiries, questions through e-mail

#### Epson Hotline

- Sales enquiries and product information
- Technical support

Phone (62) 21-572 4350

Fax (62) 21-572 4357

#### Epson Service Center

Jakarta Mangga Dua Mall 3rd floor No 3A/B  
Jl. Arteri Mangga Dua,  
Jakarta

Phone/Fax: (62) 21-62301104

## Where To Get Help

Bandung	Lippo Center 8th floor Jl. Gatot Subroto No.2 Bandung  Phone/Fax: (62) 22-7303766
Surabaya	Hitech Mall It IIB No. 12 Jl. Kusuma Bangsa 116 – 118 Surabaya  Phone: (62) 31-5355035 Fax: (62)31-5477837
Yogyakarta	Hotel Natour Garuda Jl. Malioboro No. 60 Yogyakarta  Phone: (62) 274-565478
Medan	Wisma HSBC 4th floor Jl. Diponegoro No. 11 Medan  Phone/Fax: (62) 61-4516173
Makassar	MTC Karebosi Lt. III Kav. P7-8 Jl. Ahmad Yani No.49 Makassar  Phone: (62)411-350147/411-350148

---

## Help for Users in Hong Kong

To obtain technical support as well as other after-sales services, users are welcome to contact Epson Hong Kong Limited.

### Internet Home Page

Epson Hong Kong has established a local home page in both Chinese and English on the Internet to provide users with the following information:

- Product information
- Answers to Frequently Asked Questions (FAQs)
- Latest versions of Epson product drivers

Users can access our World Wide Web home page at:

<http://www.epson.com.hk>

## Technical Support Hotline

You can also contact our technical staff at the following telephone and fax numbers:

Phone: (852) 2827-8911

Fax: (852) 2827-4383

---

## Help for Users in Malaysia

Contacts for information, support, and services are:

### World Wide Web

(<http://www.epson.com.my>)

- Information on product specifications, drivers for download
- Frequently Asked Questions (FAQ), Sales Enquiries, questions through e-mail

### Epson Trading (M) Sdn. Bhd.

Head Office.

Phone: 603-56288288

Fax: 603-56288388/399

### Epson Helpdesk

- Sales enquiries and product information (Infoline)

Phone: 603-56288222

- Enquiries on repair services & warranty, product usage and technical support (Techline)

Phone: 603-56288333

---

## Help for Users in India

Contacts for information, support, and services are:

## Where To Get Help

### World Wide Web

(<http://www.epson.co.in>)

Information on product specifications, drivers for download, and products enquiry are available.

### Epson India Head Office - Bangalore

Phone: 080-30515000

Fax: 30515005

### Epson India Regional Offices:

Location	Telephone number	Fax number
Mumbai	022-28261515 / 16/17	022-28257287
Delhi	011-30615000	011-30615005
Chennai	044-30277500	044-30277575
Kolkata	033-22831589 / 90	033-22831591
Hyderabad	040-66331738/ 39	040-66328633
Cochin	0484-2357950	0484-2357950
Coimbatore	0422-2380002	NA
Pune	020-30286000 / 30286001 / 30286002	020-30286000
Ahmedabad	079-26407176 / 77	079-26407347

### Helpline

For Service, Product info or to order a cartridge - 18004250011 (9AM - 9PM) - This is a Toll-free number.

For Service (CDMA & Mobile Users) - 3900 1600 (9AM - 6PM) Prefix local STD code

## Help for Users in the Philippines

To obtain technical support as well as other after sales services, users are welcome to contact the Epson Philippines Corporation at the telephone and fax numbers and e-mail address below:

Trunk Line: (63-2) 706 2609

Fax: (63-2) 706 2665

Helpdesk Direct Line: (63-2) 706 2625

E-mail: [epchelpdesk@epc.epson.com.ph](mailto:epchelpdesk@epc.epson.com.ph)

### World Wide Web

(<http://www.epson.com.ph>)

Information on product specifications, drivers for download, Frequently Asked Questions (FAQ), and E-mail Enquiries are available.

**Toll-Free No. 1800-1069-EPSON(37766)**

Our Hotline team can help you with the following over the phone:

- Sales enquiries and product information
- Product usage questions or problems
- Enquiries on repair service and warranty



**Software License Terms**

---

# Software License Terms

---

## Open Source Software Licenses

---

### Bonjour

This printer product includes the open source software programs which apply the Apple Public Source License Version 1.2 or its latest version ("Bonjour Programs").

We provide the source code of the Bonjour Programs pursuant to the Apple Public Source License Version 1.2 or its latest version until five (5) years after the discontinuation of same model of this printer product. If you desire to receive the source code of the Bonjour Programs, please see the "Contacting Customer Support" in Appendix or Printing Guide of this User's Guide, and contact the customer support of your region.

You can redistribute Bonjour Programs and/or modify it under the terms of the Apple Public Source License Version 1.2 or its latest version.

These Bonjour Programs are WITHOUT ANY WARRANTY; without even the implied warranty of MERCHANTABILITY AND FITNESS FOR A PARTICULAR PURPOSE.

The Apple Public Source License Version 1.2 is as follows. You also can see the Apple Public Source License Version 1.2 at <http://www.opensource.apple.com/apsl/>.

APPLE PUBLIC SOURCE LICENSE  
Version 2.0 - August 6, 2003

1. General; Definitions. This License applies to any program or other work which Apple Computer, Inc. ("Apple") makes publicly available and which contains a notice placed by Apple identifying such program or work as "Original Code" and stating that it is subject to the terms of this Apple Public Source License version 2.0 ("License"). As used in this License:

1.1 "Applicable Patent Rights" mean: (a) in the case where Apple is the grantor of rights, (i) claims of patents that are now or hereafter acquired, owned by or assigned to Apple and (ii) that cover subject matter contained in the Original Code, but only to the extent necessary to use, reproduce and/or distribute the Original Code without infringement; and (b) in the case where You are the grantor of rights, (i) claims of patents that are now or hereafter acquired, owned by or assigned to You and (ii) that cover subject matter in Your Modifications, taken alone or in combination with Original Code.

1.2 "Contributor" means any person or entity that creates or contributes to the creation of Modifications.

1.3 "Covered Code" means the Original Code, Modifications, the combination of Original Code and any Modifications, and/or any respective portions thereof.

1.4 "Externally Deploy" means: (a) to sublicense, distribute or otherwise make Covered Code available, directly or indirectly, to anyone other than You; and/or (b) to use Covered Code, alone or as part of a Larger Work, in any way to provide a service, including but not limited to delivery of content, through electronic communication with a client other than You.

1.5 "Larger Work" means a work which combines Covered Code or portions thereof with code not governed by the terms of this License.

## Software License Terms

1.6 "Modifications" mean any addition to, deletion from, and/or change to, the substance and/or structure of the Original Code, any previous Modifications, the combination of Original Code and any previous Modifications, and/or any respective portions thereof. When code is released as a series of files, a Modification is: (a) any addition to or deletion from the contents of a file containing Covered Code; and/or (b) any new file or other representation of computer program statements that contains any part of Covered Code.

1.7 "Original Code" means (a) the Source Code of a program or other work as originally made available by Apple under this License, including the Source Code of any updates or upgrades to such programs or works made available by Apple under this License, and that has been expressly identified by Apple as such in the header file(s) of such work; and (b) the object code compiled from such Source Code and originally made available by Apple under this License

1.8 "Source Code" means the human readable form of a program or other work that is suitable for making modifications to it, including all modules it contains, plus any associated interface definition files, scripts used to control compilation and installation of an executable (object code).

1.9 "You" or "Your" means an individual or a legal entity exercising rights under this License. For legal entities, "You" or "Your" includes any entity which controls, is controlled by, or is under common control with, You, where "control" means (a) the power, direct or indirect, to cause the direction or management of such entity, whether by contract or otherwise, or (b) ownership of fifty percent (50%) or more of the outstanding shares or beneficial ownership of such entity.

2. Permitted Uses; Conditions & Restrictions. Subject to the terms and conditions of this License, Apple hereby grants You, effective on the date You accept this License and download the Original Code, a world-wide, royalty-free, non-exclusive license, to the extent of Apple's Applicable Patent Rights and copyrights covering the Original Code, to do the following:

2.1 Unmodified Code. You may use, reproduce, display, perform, internally distribute within Your organization, and Externally Deploy verbatim, unmodified copies of the Original Code, for commercial or non-commercial purposes, provided that in each instance:

(a) You must retain and reproduce in all copies of Original Code the copyright and other proprietary notices and disclaimers of Apple as they appear in the Original Code, and keep intact all notices in the Original Code that refer to this License; and

(b) You must include a copy of this License with every copy of Source Code of Covered Code and documentation You distribute or Externally Deploy, and You may not offer or impose any terms on such Source Code that alter or restrict this License or the recipients' rights hereunder, except as permitted under Section 6.

2.2 Modified Code. You may modify Covered Code and use, reproduce, display, perform, internally distribute within Your organization, and Externally Deploy Your Modifications and Covered Code, for commercial or non-commercial purposes, provided that in each instance You also meet all of these conditions:

(a) You must satisfy all the conditions of Section 2.1 with respect to the Source Code of the Covered Code;

(b) You must duplicate, to the extent it does not already exist, the notice in Exhibit A in each file of the Source Code of all Your Modifications, and cause the modified files to carry prominent notices stating that You changed the files and the date of any change; and

(c) If You Externally Deploy Your Modifications, You must make Source Code of all Your Externally Deployed Modifications either available to those to whom You have Externally Deployed Your Modifications, or publicly available. Source Code of Your Externally Deployed Modifications must be released under the terms set forth in this License, including the license grants set forth in Section 3 below, for as long as you Externally Deploy the Covered Code or twelve (12) months from the date of initial External Deployment, whichever is longer. You should preferably distribute the Source Code of Your Externally Deployed Modifications electronically (e.g. download from a web site).

## Software License Terms

2.3 Distribution of Executable Versions. In addition, if You Externally Deploy Covered Code (Original Code and/or Modifications) in object code, executable form only, You must include a prominent notice, in the code itself as well as in related documentation, stating that Source Code of the Covered Code is available under the terms of this License with information on how and where to obtain such Source Code.

2.4 Third Party Rights. You expressly acknowledge and agree that although Apple and each Contributor grants the licenses to their respective portions of the Covered Code set forth herein, no assurances are provided by Apple or any Contributor that the Covered Code does not infringe the patent or other intellectual property rights of any other entity. Apple and each Contributor disclaim any liability to You for claims brought by any other entity based on infringement of intellectual property rights or otherwise. As a condition to exercising the rights and licenses granted hereunder, You hereby assume sole responsibility to secure any other intellectual property rights needed, if any. For example, if a third party patent license is required to allow You to distribute the Covered Code, it is Your responsibility to acquire that license before distributing the Covered Code.

3. Your Grants. In consideration of, and as a condition to, the licenses granted to You under this License, You hereby grant to any person or entity receiving or distributing Covered Code under this License a non-exclusive, royalty-free, perpetual, irrevocable license, under Your Applicable Patent Rights and other intellectual property rights (other than patent) owned or controlled by You, to use, reproduce, display, perform, modify, sublicense, distribute and Externally Deploy Your Modifications of the same scope and extent as Apple's licenses under Sections 2.1 and 2.2 above.

4. Larger Works. You may create a Larger Work by combining Covered Code with other code not governed by the terms of this License and distribute the Larger Work as a single product. In each such instance, You must make sure the requirements of this License are fulfilled for the Covered Code or any portion thereof.

5. Limitations on Patent License. Except as expressly stated in Section 2, no other patent rights, express or implied, are granted by Apple herein. Modifications and/or Larger Works may require additional patent licenses from Apple which Apple may grant in its sole discretion.

6. Additional Terms. You may choose to offer, and to charge a fee for, warranty, support, indemnity or liability obligations and/or other rights consistent with the scope of the license granted herein ("Additional Terms") to one or more recipients of Covered Code. However, You may do so only on Your own behalf and as Your sole responsibility, and not on behalf of Apple or any Contributor. You must obtain the recipient's agreement that any such Additional Terms are offered by You alone, and You hereby agree to indemnify, defend and hold Apple and every Contributor harmless for any liability incurred by or claims asserted against Apple or such Contributor by reason of any such Additional Terms.

7. Versions of the License. Apple may publish revised and/or new versions of this License from time to time. Each version will be given a distinguishing version number. Once Original Code has been published under a particular version of this License, You may continue to use it under the terms of that version. You may also choose to use such Original Code under the terms of any subsequent version of this License published by Apple. No one other than Apple has the right to modify the terms applicable to Covered Code created under this License.

## Software License Terms

8. NO WARRANTY OR SUPPORT. The Covered Code may contain in whole or in part pre-release, untested, or not fully tested works. The Covered Code may contain errors that could cause failures or loss of data, and may be incomplete or contain inaccuracies. You expressly acknowledge and agree that use of the Covered Code, or any portion thereof, is at Your sole and entire risk. THE COVERED CODE IS PROVIDED "AS IS" AND WITHOUT WARRANTY, UPGRADES OR SUPPORT OF ANY KIND AND APPLE AND APPLE'S LICENSOR(S) (COLLECTIVELY REFERRED TO AS "APPLE" FOR THE PURPOSES OF SECTIONS 8 AND 9) AND ALL CONTRIBUTORS EXPRESSLY DISCLAIM ALL WARRANTIES AND/OR CONDITIONS, EXPRESS OR IMPLIED, INCLUDING, BUT NOT LIMITED TO, THE IMPLIED WARRANTIES AND/OR CONDITIONS OF MERCHANTABILITY, OF SATISFACTORY QUALITY, OF FITNESS FOR A PARTICULAR PURPOSE, OF ACCURACY, OF QUIET ENJOYMENT, AND NONINFRINGEMENT OF THIRD PARTY RIGHTS. APPLE AND EACH CONTRIBUTOR DOES NOT WARRANT AGAINST INTERFERENCE WITH YOUR ENJOYMENT OF THE COVERED CODE, THAT THE FUNCTIONS CONTAINED IN THE COVERED CODE WILL MEET YOUR REQUIREMENTS, THAT THE OPERATION OF THE COVERED CODE WILL BE UNINTERRUPTED OR ERROR-FREE, OR THAT DEFECTS IN THE COVERED CODE WILL BE CORRECTED. NO ORAL OR WRITTEN INFORMATION OR ADVICE GIVEN BY APPLE, AN APPLE AUTHORIZED REPRESENTATIVE OR ANY CONTRIBUTOR SHALL CREATE A WARRANTY. You acknowledge that the Covered Code is not intended for use in the operation of nuclear facilities, aircraft navigation, communication systems, or air traffic control machines in which case the failure of the Covered Code could lead to death, personal injury, or severe physical or environmental damage.

9. LIMITATION OF LIABILITY. TO THE EXTENT NOT PROHIBITED BY LAW, IN NO EVENT SHALL APPLE OR ANY CONTRIBUTOR BE LIABLE FOR ANY INCIDENTAL, SPECIAL, INDIRECT OR CONSEQUENTIAL DAMAGES ARISING OUT OF OR RELATING TO THIS LICENSE OR YOUR USE OR INABILITY TO USE THE COVERED CODE, OR ANY PORTION THEREOF, WHETHER UNDER A THEORY OF CONTRACT, WARRANTY, TORT (INCLUDING NEGLIGENCE), PRODUCTS LIABILITY OR OTHERWISE, EVEN IF APPLE OR SUCH CONTRIBUTOR HAS BEEN ADVISED OF THE POSSIBILITY OF SUCH DAMAGES AND NOTWITHSTANDING THE FAILURE OF ESSENTIAL PURPOSE OF ANY REMEDY. SOME JURISDICTIONS DO NOT ALLOW THE LIMITATION OF LIABILITY OF INCIDENTAL OR CONSEQUENTIAL DAMAGES, SO THIS LIMITATION MAY NOT APPLY TO YOU. In no event shall Apple's total liability to You for all damages (other than as may be required by applicable law) under this License exceed the amount of fifty dollars (\$50.00).

10. Trademarks. This License does not grant any rights to use the trademarks or trade names "Apple", "Apple Computer", "Mac", "Mac OS", "QuickTime", "QuickTime Streaming Server" or any other trademarks, service marks, logos or trade names belonging to Apple (collectively "Apple Marks") or to any trademark, service mark, logo or trade name belonging to any Contributor. You agree not to use any Apple Marks in or as part of the name of products derived from the Original Code or to endorse or promote products derived from the Original Code other than as expressly permitted by and in strict compliance at all times with Apple's third party trademark usage guidelines which are posted at <http://www.apple.com/legal/guidelinesfor3rdparties.html>.

11. Ownership. Subject to the licenses granted under this License, each Contributor retains all rights, title and interest in and to any Modifications made by such Contributor. Apple retains all rights, title and interest in and to the Original Code and any Modifications made by or on behalf of Apple ("Apple Modifications"), and such Apple Modifications will not be automatically subject to this License. Apple may, at its sole discretion, choose to license such Apple Modifications under this License, or on different terms from those contained in this License or may choose not to license them at all.

12. Termination.

12.1 Termination. This License and the rights granted hereunder will terminate:

(a) automatically without notice from Apple if You fail to comply with any term(s) of this License and fail to cure such breach within 30 days of becoming aware of such breach;

(b) immediately in the event of the circumstances described in Section 13.5(b); or

## Software License Terms

(c) automatically without notice from Apple if You, at any time during the term of this License, commence an action for patent infringement against Apple; provided that Apple did not first commence an action for patent infringement against You in that instance.

12.2 Effect of Termination. Upon termination, You agree to immediately stop any further use, reproduction, modification, sublicensing and distribution of the Covered Code. All sublicenses to the Covered Code which have been properly granted prior to termination shall survive any termination of this License. Provisions which, by their nature, should remain in effect beyond the termination of this License shall survive, including but not limited to Sections 3, 5, 8, 9, 10, 11, 12.2 and 13. No party will be liable to any other for compensation, indemnity or damages of any sort solely as a result of terminating this License in accordance with its terms, and termination of this License will be without prejudice to any other right or remedy of any party.

### 13. Miscellaneous.

13.1 Government End Users. The Covered Code is a "commercial item" as defined in FAR 2.101. Government software and technical data rights in the Covered Code include only those rights customarily provided to the public as defined in this License. This customary commercial license in technical data and software is provided in accordance with FAR 12.211 (Technical Data) and 12.212 (Computer Software) and, for Department of Defense purchases, DFAR 252.227-7015 (Technical Data -- Commercial Items) and 227.7202-3 (Rights in Commercial Computer Software or Computer Software Documentation). Accordingly, all U.S. Government End Users acquire Covered Code with only those rights set forth herein.

13.2 Relationship of Parties. This License will not be construed as creating an agency, partnership, joint venture or any other form of legal association between or among You, Apple or any Contributor, and You will not represent to the contrary, whether expressly, by implication, appearance or otherwise.

13.3 Independent Development. Nothing in this License will impair Apple's right to acquire, license, develop, have others develop for it, market and/or distribute technology or products that perform the same or similar functions as, or otherwise compete with, Modifications, Larger Works, technology or products that You may develop, produce, market or distribute.

13.4 Waiver; Construction. Failure by Apple or any Contributor to enforce any provision of this License will not be deemed a waiver of future enforcement of that or any other provision. Any law or regulation which provides that the language of a contract shall be construed against the drafter will not apply to this License.

13.5 Severability. (a) If for any reason a court of competent jurisdiction finds any provision of this License, or portion thereof, to be unenforceable, that provision of the License will be enforced to the maximum extent permissible so as to effect the economic benefits and intent of the parties, and the remainder of this License will continue in full force and effect. (b) Notwithstanding the foregoing, if applicable law prohibits or restricts You from fully and/or specifically complying with Sections 2 and/or 3 or prevents the enforceability of either of those Sections, this License will immediately terminate and You must immediately discontinue any use of the Covered Code and destroy all copies of it that are in your possession or control.

13.6 Dispute Resolution. Any litigation or other dispute resolution between You and Apple relating to this License shall take place in the Northern District of California, and You and Apple hereby consent to the personal jurisdiction of, and venue in, the state and federal courts within that District with respect to this License. The application of the United Nations Convention on Contracts for the International Sale of Goods is expressly excluded.

13.7 Entire Agreement; Governing Law. This License constitutes the entire agreement between the parties with respect to the subject matter hereof. This License shall be governed by the laws of the United States and the State of California, except that body of California law concerning conflicts of law.

Where You are located in the province of Quebec, Canada, the following clause applies: The parties hereby confirm that they have requested that this License and all related documents be drafted in English.

Les parties ont exigé que le présent contrat et tous les documents connexes soient rédigés en anglais.

## Software License Terms

### EXHIBIT A.

"Portions Copyright (c) 1999-2003 Apple Computer, Inc. All Rights Reserved.

This file contains Original Code and/or Modifications of Original Code as defined in and that are subject to the Apple Public Source License Version 2.0 (the 'License'). You may not use this file except in compliance with the License. Please obtain a copy of the License at <http://www.opensource.apple.com/apsl/> and read it before using this file.

The Original Code and all software distributed under the License are distributed on an 'AS IS' basis, WITHOUT WARRANTY OF ANY KIND, EITHER EXPRESS OR IMPLIED, AND APPLE HEREBY DISCLAIMS ALL SUCH WARRANTIES, INCLUDING WITHOUT LIMITATION, ANY WARRANTIES OF MERCHANTABILITY, FITNESS FOR A PARTICULAR PURPOSE, QUIET ENJOYMENT OR NON-INFRINGEMENT. Please see the License for the specific language governing rights and limitations under the License."

## Other Software Licenses

---

### Info-ZIP copyright and license

This is version 2007-Mar-4 of the Info-ZIP license. The definitive version of this document should be available at <ftp://ftp.info-zip.org/pub/infozip/license.html> indefinitely and a copy at <http://www.info-zip.org/pub/infozip/license.html>.

Copyright © 1990-2007 Info-ZIP. All rights reserved.

For the purposes of this copyright and license, "Info-ZIP" is defined as the following set of individuals:

Mark Adler, John Bush, Karl Davis, Harald Denker, Jean-Michel Dubois, Jean-loup Gailly, Hunter Goatley, Ed Gordon, Ian Gorman, Chris Herborth, Dirk Haase, Greg Hartwig, Robert Heath, Jonathan Hudson, Paul Kienitz, David Kirschbaum, Johnny Lee, Onno van der Linden, Igor Mandrichenko, Steve P. Miller, Sergio Monesi, Keith Owens, George Petrov, Greg Roelofs, Kai Uwe Rommel, Steve Salisbury, Dave Smith, Steven M. Schweda, Christian Spieler, Cosmin Truta, Antoine Verheijen, Paul von Behren, Rich Wales, Mike White.

Permission is granted to anyone to use this software for any purpose, including commercial applications, and to alter it and redistribute it freely, subject to the above disclaimer and the following restrictions:

1. Redistributions of source code (in whole or in part) must retain the above copyright notice, definition, disclaimer, and this list of conditions.
2. Redistributions in binary form (compiled executables and libraries) must reproduce the above copyright notice, definition, disclaimer, and this list of conditions in documentation and/or other materials provided with the distribution. The sole exception to this condition is redistribution of a standard UnZipSFX binary (including SFXWiz) as part of a self-extracting archive; that is permitted without inclusion of this license, as long as the normal SFX banner has not been removed from the binary or disabled.

### Software License Terms

3. Altered versions--including, but not limited to, ports to new operating systems, existing ports with new graphical interfaces, versions with modified or added functionality, and dynamic, shared, or static library versions not from Info-ZIP--must be plainly marked as such and must not be misrepresented as being the original source or, if binaries, compiled from the original source. Such altered versions also must not be misrepresented as being Info-ZIP releases--including, but not limited to, labeling of the altered versions with the names "Info-ZIP" (or any variation thereof, including, but not limited to, different capitalizations), "Pocket UnZip," "WiZ" or "MacZip" without the explicit permission of Info-ZIP. Such altered versions are further prohibited from misrepresentative use of the Zip-Bugs or Info-ZIP e-mail addresses or the Info-ZIP URL(s), such as to imply Info-ZIP will provide support for the altered versions.
4. Info-ZIP retains the right to use the names "Info-ZIP," "Zip," "UnZip," "UnZipSFX," "WiZ," "Pocket UnZip," "Pocket Zip," and "MacZip" for its own source and binary releases.