

# INSTALLATION GUIDE

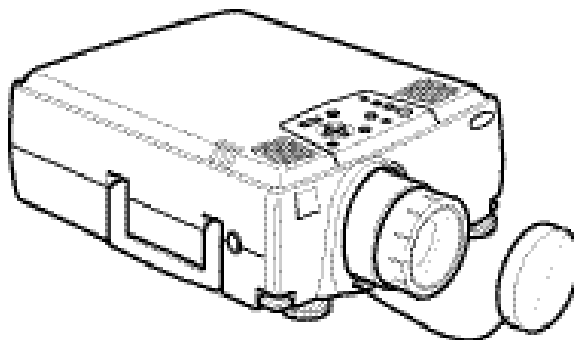

**EPSON®**

# Contents

- 1.Safety Instructions .....5
- 2.Installation .....7
  - 2-1.Projection distance between projector and screen .....7
    - 2-1-1.When using the standard lens .....7
      - <Model EMP-8000> .....8
    - 2-1-2.When using the long zoom lens ELPLL02 (optional) .....9
    - 2-1-3.When using the long zoom lens ELPLL01 (optional) .....10
      - Attaching the LONG THROW ZOOM LENS .....11
    - 2-1-4.When using the wide conversion lens (ELPCW01) .....16
    - 2-1-5.When using the wide zoom lens ELPLW01 (optional) .....17
  - 2-2.Cabling .....20
    - 2-2-1.Connecting to a computer .....20
      - Projecting the computer image .....20
        - <Connecting two computers> .....21
        - <Projecting the projector image on a monitor display> .....22
        - <Outputting the computer voice from the projector> .....23
        - <Connecting a computer directly to external audio equipment> .....23
        - <Outputting the computer voice input to the projector from external audio equipment> ...24
      - <Connecting to a workstation> .....25
        - <If the workstation is a 5BNC port (1):> .....26
        - <If the workstation is a 5BNC port (2):> .....26
    - 2-2-2.Connecting to a video source .....27
      - Inputting the composite video signal .....27
      - Inputting the S-Video signal .....27
      - Inputting the component (color-difference) video signal .....28
      - Inputting the composite video signal .....29
      - Inputting the S-Video signal .....29
      - Inputting the component (color-difference) video signal .....30
      - Setting the BNC terminal entry mode .....31
  - 2-3.Mounting Position and Location .....32
    - 2-3-1.Positioning the projector and screen .....32
      - Positioning the projector and screen .....32
    - 2-3-2.Assembly and Mounting .....33
      - Projector Mounting .....33
      - Installing on the Ceiling .....33
    - 2-3-3.Adjustment Function .....34
    - 2-3-4.Example of mounting to ceiling .....35
      - For concrete ceilings .....35
    - 2-3-5.Ceiling Plate and Pipe Configurations .....36
      - Ceiling plate configuration .....36
      - Pipe configurations .....36
      - Securing the Ceiling Plate to the Ceiling .....37
      - Installing the Pipe .....37
      - Installing to the Ceiling .....37
    - 2-3-6.Using the ceiling mounting bracket fixture and pipe .....39
      - Installing the Flange .....39

2-3-7.Adjustment Function	.42
• Using the ceiling-hung projector	.43
• Projecting the image from the behind of the screen	
using the ceiling-hung projector	.44
2-3-8.Checking that the projector is operational	.45
3.Installing the stack multi-screen(Model EMP-8000 only)	.46
3-1.The following tips should be kept in mind when you install the	
stack multi-screen:	.46
3-2.Connection for stack projection of the computer image	.47
3-2-1.If the computer has a 15-pin micro-D-style (BNC) output port	.47
3-2-2.Adjustment before stack projection	.49
<Adjusting the color with the test pattern>	.49
• For Windows users:	.49
• Using the lens shift function	.50
• Color setting	.51
3-3.Operating/controlling the stack-connected projectors	.52
3-3-1.Establishing the stack-connection	.52
• For Macintosh users:	.52
3-3-2.Operating the stack-connected projectors	.56
• Turn on all projectors at a time	.56
3-3-3.Alert message on the Installer specific setting window	.56
3-3-4.Using the setting menu	.57
• For Windows users:	.57
• For Macintosh users:	.58
3-3-5.Operations and restrictions on the stack-connection	.60
• Operations	.60
4.Installing the remote control receiver	.61
4-1.Installing	.61
5.Maintenance	.62
5-1.Replacing the lamp	.63
5-1-1.Model EMP-7350/EMP-7250/EMP-5350	.63
5-1-2.Model EMP-8000	.65
5-2.Replacing the air filter	.67
5-2-1.Model EMP-7350/EMP-7250/EMP-5350	.67
5-2-2.Model EMP-8000	.68
6.Product specifications	.69
6-1.Projector specifications	.69
6-1-1.Model EMP-7350/EMP-7250/EMP-5350	.69
6-1-2.Model EMP-8000	.70
6-2.Lens specifications	.71
6-2-1.Long zoom lens (ELPLL02)	.71
6-2-2.Wide conversion lens (ELPCW01)	.71
6-3.Using the control panel on the projector	.72
6-3-1.Model EMP-7350/EMP-7250/EMP-5350	.72
6-3-2.Model EMP-8000	.74
6-4.Using the remote control	.76

6-4-1.Front	.76
6-4-2.Inside of the cover	.77
6-5.I/O terminals	.78
6-5-1.Model EMP-7350/EMP-7250/EMP-5350	.78
6-5-2.Model EMP-8000	.80
6-6.Dimensional diagram	.82
6-6-1.Projector<Model EMP-8000>	.82
6-6-2.I/O panel	.84
6-7.Connector pin assignments	.85
6-7-1.Computer1/2 In	.85
6-7-2.Audio1 In	.85
6-7-3.Audio Out	.86
6-7-4.Computer Out(Model EMP-800:Monitor Out)	.86
6-7-5.S-Video In	.87
6-7-6.L-Audio-R	.87
6-7-7.L-Audio2-R	.87
6-7-8.Video	.87
6-7-9.Mouse/Com	.88
6-7-10.Remote	.88
6-8.Main cable	.89

# 1.Safety Instructions



## Warning

- The installation procedure described in this manual is written for your dealer with who has the adequate know-how and skill to install the projector.
- In the following situations turn off the projector, and unplug it from the wall outlet.
  - If smoke is detected, or if an unusual smell or noise is present.
  - If the projector does not work properly due to a failure including no image and no sound on the screen.
  - If liquid or foreign matter has been entered into the projector.
  - If the projector has been dropped or the housing has been damaged.Failure to do so may result in fire or electric shock.
- Never open the cabinet of the projector except for your dealer or qualified service personnel. Do not disassemble or modify the projector under any circumstances. Dangerous electrical voltages inside the projector can cause fire, electric shock, or injury.
- Use the type of power source indicated on the projector. Failure to do so may result in fire or electric shock.
- Use the power cable supplied with the projector. Failure to do so may result in fire or electric shock.
- Do not use the damaged power cable. Failure to do so may result in fire or electric shock. Always take the following precautions when handling the power cable.
  - Do not work on the power cable.
  - Do not place a heavy object on the power cable.
  - Do not bend, twist or pull the power cable by forcing.
  - Do not lay the power cable near a heater.Replace the damaged power cable with the new one.
- Never look into the projector lens when the lamp is switched on. The bright light can damage your eyes.
- Extra special care must be taken on handling the power plug/power connector. Failure to do so may result in fire or electric shock. Always take the following precautions when handling the power plug/power connector.
  - Avoid the star-burst connection.
  - Ensure that the power plug/power connector is free of dust before inserting it into a socket.
  - Ensure that the power plug/power connector is inserted into the socket securely.
  - Do not insert or disconnect the power plug/power connector with wet hands.
  - Do not pull the power cable to disconnect the power plug/power connector. Always disconnect the power plug holding the plug or connector itself.
- A lot of glass components such as a lens and lamp are employed in the projector. If any of the components is broken, handle it so you do not cut yourself. Refer all servicing to the EPSON Service Center.
- Do not place a vase, container filled with water, or chemicals on the projector. Failure to do so may result in fire or electric shock due to spillover or entry of water or chemicals.
- Do not insert or drop objects of any kind including a metal, flammable material, and foreign matter into the openings such as the vent hole on the projector. Failure to do so may result in fire or electric shock.
- Do not place the projector or remote control with batteries inserted in an extremely heated place, such as a car with all windows closed, an area exposed to direct sunlight, and an air flap of an air conditioner/heater. It may result in deformation due to heat, or the adverse effect on the components inside the projector which may lead to fire.
- Do not step on the projector or place a heavy object on it.

- Failure to do so may result in injury due to falling or breakage.
- Do not place the projector on an unstable place such as a wobbly or inclined stand.  
Failure to do so may result in injury due to dropping or breakage.
- Install or keep the projector out of the reach of children.  
Failure to do so may result in injury due to dropping or breakage.
- Do not place the projector on a humid or dusty place, or near a place with greasy fumes/steam given off such as a cookware or humidifier.  
Failure to do so may result in fire or electric shock.
- Do not block the intake fan/exhaust fan on the projector. They provide ventilation and prevent the projector from overheating which may lead to fire. Do not place the projector in a place as follows:
  - In an enclosed area such as a closet and bookcase.
  - On a rug, bedding or blanket.
  - Do not cover a cloth such as a blanket, curtain and tablecloth over the projector.
 Keep the clearance of 20 cm or more between the wall and the projector if wall-mounted.
- Turn off the projector, unplug it from the wall outlet, and ensure that all cabling is disconnected before moving the projector.  
Failure to do so may result in fire or electric shock.
- Never remove the lamp immediately after turning off the projector.
  - Failure to do so may result in burns or injury due to heat.  
Let the projector cool for about 60 minutes after turning off it. Ensure that the projector is sufficiently cooled down before replacing the lamp.
- Misuse of a battery can result in fire, injury, or corrosion on the projector due to explosion or liquid leakage. Always take the following precautions when using a battery safely.
  - Do not use batteries different in kind or old and new batteries together.
  - Always use the type of battery indicated in the instruction manual.
  - Wipe off liquid leaked from a battery with a cloth, and replace it with the new one.
  - Replace a dead battery with the new one immediately.
  - Remove batteries if you will not use the projector for an extended time.
  - Do not heat s battery or dispose of it in fire or water.
  - Check the polarity (+, -) before inserting a battery.
  - Wash your hands immediately if leaked liquid has contacted to them.
 Dispose of an old battery following the local regulations.
- Disconnect the power plug/power connector from the wall outlet before cleaning.  
Failure to do so may result in electric shock.

## 2.Installation

### 2-1.Projection distance between projector and screen

First of all, determine the projection distance between the projector and the screen. Then, place the projector the correct distance from the screen.

#### 2-1-1.When using the standard lens

##### <Model EMP-7350/EMP-7250/EMP-5350>

- Adjust the distance between the projector lens and screen so that the desired image size is obtained.
- The projectors that can be mounted with this bracket are equipped with 1.3X zoom lenses. Thus, the maximum enlargement of the projected image size is 1.3 times the minimum enlargement. The relationship between projection distance and screen size is as shown in the table below. Ideal images are obtained with a projection distance of from 1.6m to 16.7m.

\* If a screen size other than those shown above is used, determine the correct distance between

Scrrin size (cm)	Approximate Projector Distace (m)	Dimension A (see fig. below) (cm)	Dimension B (see fig. below) (cm)
300inch(610x457)	12.4-16.7	437.0	23.0
200inch(406x305)	8.3-11.1	285.0	15.0
100inch(203x152)	4.1-5.5	142.5	7.5
80inch(163x122)	3.3-4.4	114.0	6.0
60inch(122x91)	2.5-3.3	85.5	4.5
40inch(81x61)	1.6-2.1	58.0	3.1
30inch(61x46)	1.6	43.7	2.3

the projector and the screen according to the following expression.

Maximum screen size(cm)=0.612 X Projector to screen(cm) + 3.877

Minmun screen size(cm)=0.456 X Projector to screen(cm) + 2.898

Maximun Projector to screen(cm) =2.195 X screen size(cm) - 6.361

Minmun Projector to screen(cm) =1.633 X screen size(cm) - 6.330

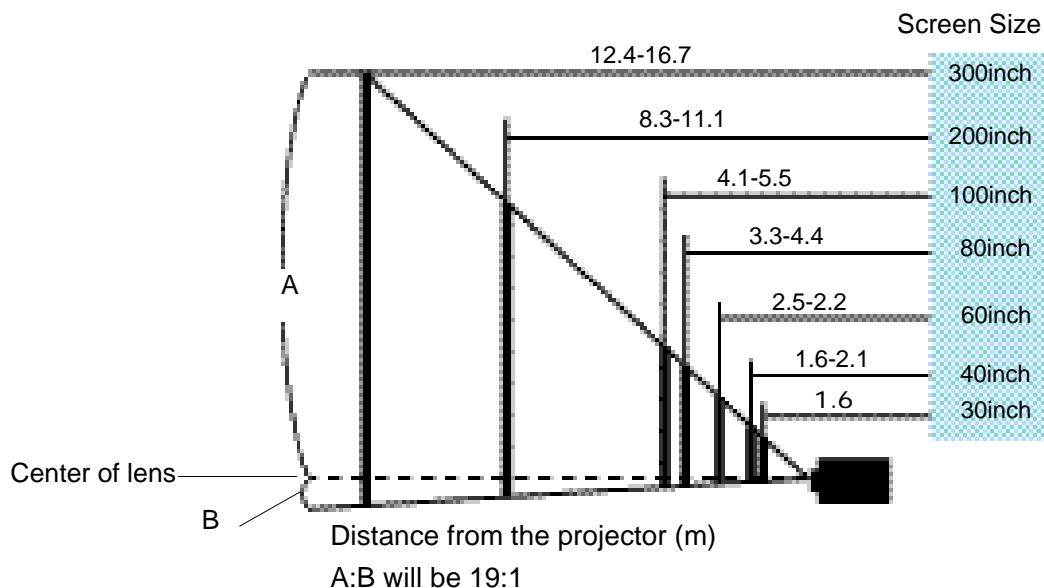

**<Model EMP-8000/EMP-9000>**

- Adjust the distance between the projector lens and screen so that the desired image size is obtained.
- The projectors that can be mounted with this bracket are equipped with 1.4X zoom lenses. Thus, the maximum enlargement of the projected image size is 1.4 times the minimum enlargement. The relationship between projection distance and screen size is as shown in the table below. Ideal images are obtained with a projection distance of from 1.1m to 15.6m.

Screen size (cm)	Approximate Projector Distace (m)	Dimension A (see fig. below) (cm)	Dimension B (see fig. below) (cm)
300inch(610x457)	11.2-15.6	460	230
200inch(406x305)	7.5-10.4	300	150
100inch(203x152)	3.7-5.1	150	75
80inch(163x122)	3.0-4.1	120	60
60inch(122x91)	2.2-3.0	90	45
40inch(81x61)	1.5-2.0	61	30.5
30inch(61x46)	1.1-1.4	46	23

\* If a screen size other than those shown above is used, determine the correct distance between the projector and the screen according to the following expression.

Maximum screen size(cm)=0.676 X Projector to screen(cm) + 5.824

Minmun screen size(cm)=0.483 X Projector to screen(cm) + 4.163

Maximun Projector to screen(cm) =2.070 X screen size(cm) - 1.334

Minmun Projector to screen(cm) =1.480 X screen size(cm) - 1.334

**10:1**

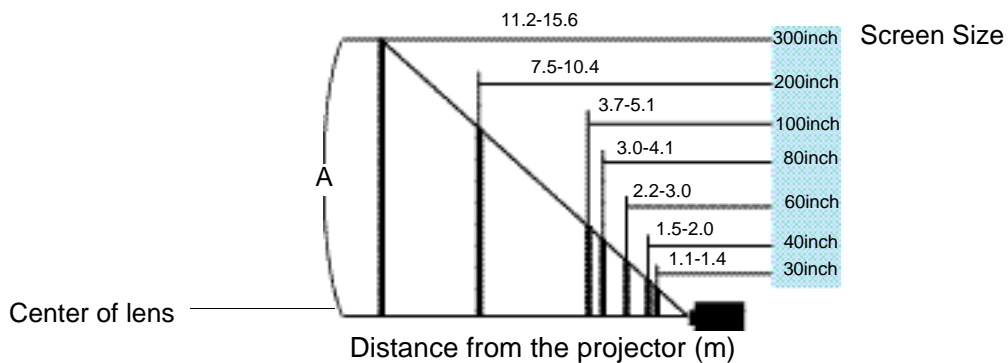

**5:5**

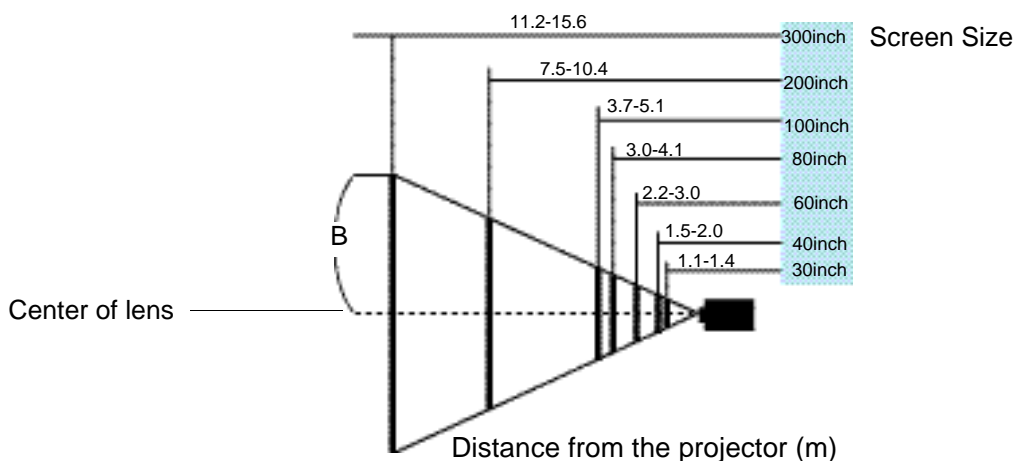



## 2-1-2. When using the long zoom lens ELPLL02 (optional)

### <ELP-8000>

The screen image in the maximum zoom in mode is projected at a size 1.7 times larger than that in the minimum zoom in mode as an 1.7:1 zoom lens is fitted as optional.

We recommend that the projection distance between the projector and the screen is set to 4.1 m to 17.6 m at installation. The following table shows the guidelines to adjust to the correct distance.

The remote control supplied with the projector offers the remote operation up to 10 m from the projector. If you want to operate the projector at a distance of 10 m or more from it, it is necessary to install and use the optional [remote control receiver ELPST02](#).

Screen size (cm)	Approximate Projector Distance (m)	
	Wide	Tele
300inch(610x457)	15.6	-
200inch(406x305)	10.4	17.6
100inch(203x152)	5.1	8.7
80inch(163x122)	4.1	6.9
60inch(122x91)	-	5.1

\* If a screen size other than those shown above is used, determine the correct distance between the projector and the screen according to the following expression.

Maximum screen size(cm)=0.487 X Projector to screen(cm) + 5.933

Minimum screen size(cm)=0.286 X Projector to screen(cm) + 3.703

Maximum Projector to screen(cm) =3.492 X screen size(cm) - 2.004

Minimum Projector to screen(cm) =2.053 X screen size(cm) - 1.888

### 2-1-3. When using the long zoom lens ELPLL01 (optional)

#### <Model EMP-7350/7250/5350>

The screen image in the maximum zoom in mode is projected at a size 1.7 times larger than that in the minimum zoom in mode as an 1.7:1 zoom lens is fitted as optional.

We recommend that the projection distance between the projector and the screen is set to 1.9 m to 25.8 m at installation. The following table shows the guidelines to adjust to the correct distance.

The remote control supplied with the projector offers the remote operation up to 10 m from the projector. If you want to operate the projector at a distance of 10 m or more from it, it is necessary to install and use the optional [remote control receiver ELPST02](#).

Screen size (cm)	Approximate Projector Distance (m)	
	Wide	Tele
300inch(610x457)	15.4	25.8
200inch(416x305)	10.5	17.5
100inch(203x152)	5.1	8.7
80inch(163x122)	4.0	6.8
60inch(122x91)	3.0	5.1
40inch(81x61)	1.9	3.3

\* If a screen size other than those shown above is used, determine the correct distance between the projector and the screen according to the following expression.

Maximum screen size(cm)=0.474 X Projector to screen(cm) + 8.252

Minimum screen size(cm)=0.285 X Projector to screen(cm) + 4.818

Maximum Projector to screen(cm) =3.509 X screen size(cm) - 16.908

Minimum Projector to screen(cm) =2.109 X screen size(cm) - 17.404

## • Attaching the LONG THROW ZOOM LENS

### Warning

- The lens is sold under the condition that it is attached by a dealer with sufficient skill and technical ability.
- Tighten the screws securely.
- Incorrect attachment of the lens may result in it falling and causing accidents if the projector is suspended.

### Memo

- Always attach or remove the lenses in a clean dust-free room. Dust inside the projector can cause malfunctions.

### <Model EMP-7350/EMP-7250/EMP-5350>

(1) Remove the rear interface panel.

- Remove the four screws and detach the interface panel.

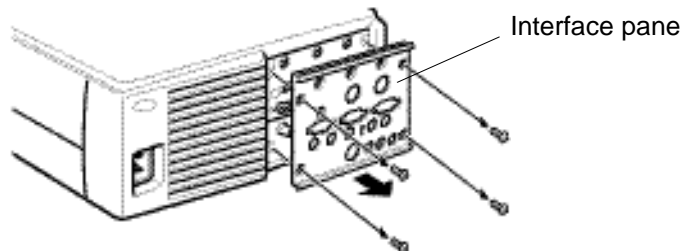

(2) Remove the front case screws.

- Remove five screws: two each side and one at the rear.
- Remove two screws: one at the handle and one at the bottom.

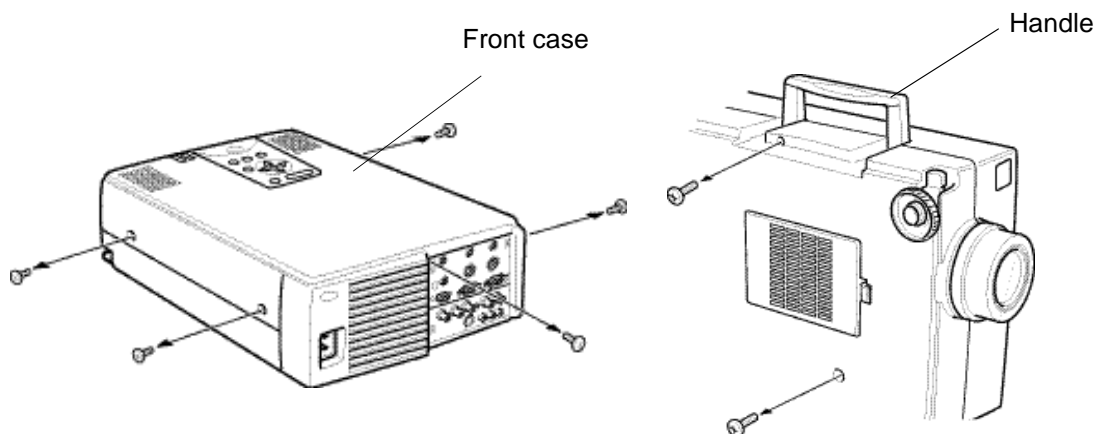

(3) Remove the operating panel lead circuit board and front case.

- Raise the front case gently to a position where the lead circuit board's connections can be checked.
- Release the connector lock and remove the lead circuit board.
- Remove the front case.

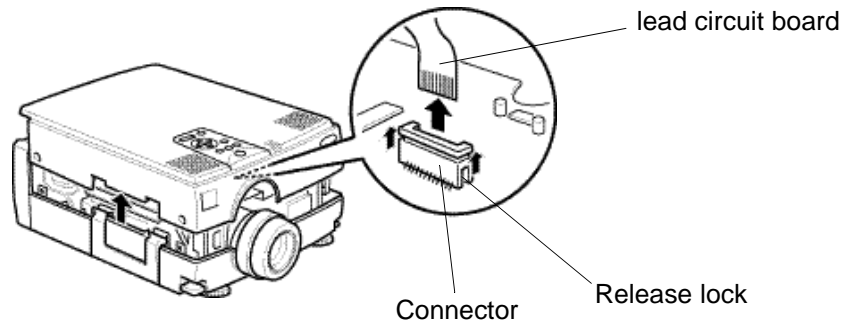

**Memo**

Be sure to remove the front case only after releasing the lead circuit board lock. Otherwise, you may damage the lead circuit board and connector.

(4) Remove the speaker unit at the left (facing to the lens).

- Remove a screw of the fixing plate for attaching the speaker unit.
- Gently lift up the speaker unit until the four screws fixing the lens can be seen.

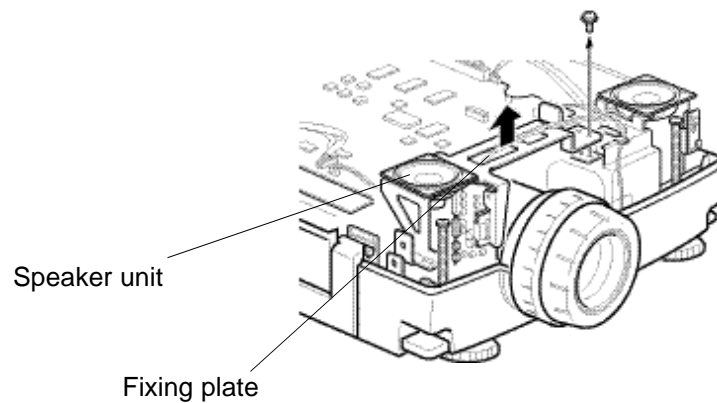

**Memo**

When moving the speaker unit, be sure to not break the wire.

(5) Removing the standard lens.

- Use the supplied screwdriver to remove the four screws, then detach the lens.

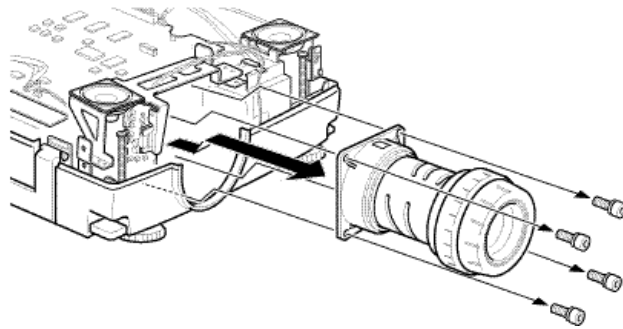

(7) Attach the LONG THROW ZOOM LENS

- Remove the lens cover attached to the lens mounting face.
- Use the supplied screwdriver to fix the lens in proper place with the four screws. Mount the lens with the seal top.

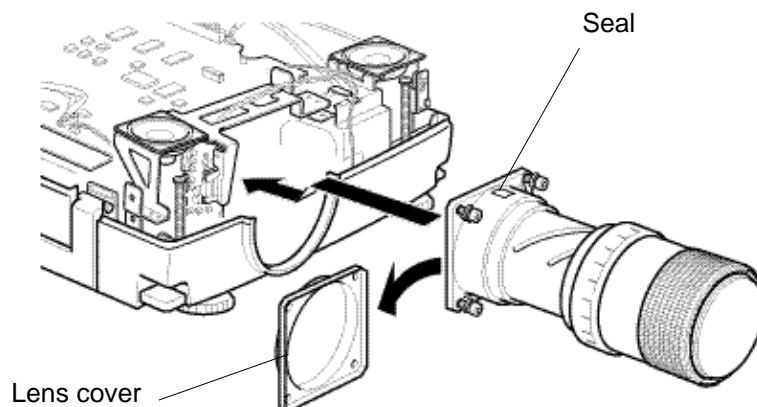

**Memo**

When re-attaching the standard lens, make sure that the seal appears on the top.

(8) Assembly

Reverse the removal procedure to attach the lens.

- Attach the speaker unit
- Insert the lead circuit board into the operating panel connector and lock it.
- Attach the front case and fasten it with the screws
- Attach the interface panel and fasten it with the screws. Assembly is now complete.
- Turn on the power to check that the [projector is operating normally](#).

**Memo**

To prevent melting of the lens cap, always remove the lens cap while the power is turned on.

**<Model EMP-8000>**

(1) Remove the rear interface panel.

- Remove the two screws and detach the interface panel.

**Memo**

Choose a Phillips screwdriver which suits the screws.

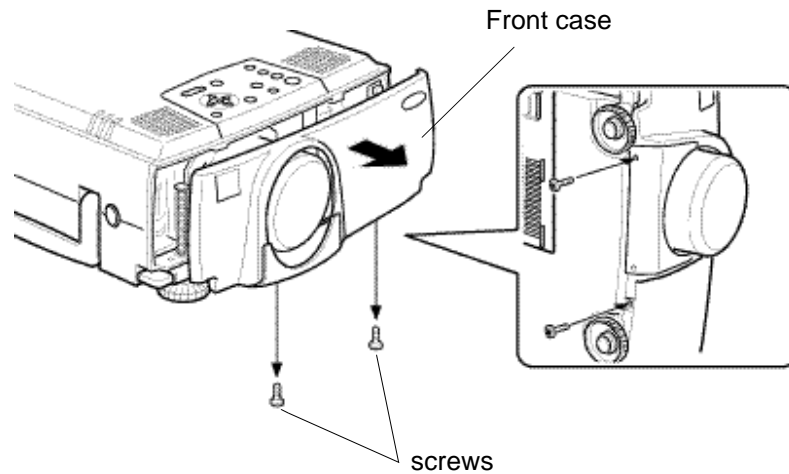

(2) Unscrew the four screws to remove the existing lens using a hexagon head screwdriver supplied with the long zoom lens.

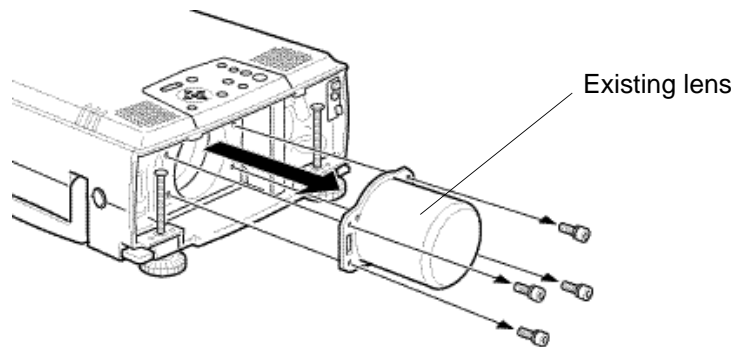

- (3) Remove the rear lens cap on the long zoom lens.
- (4) Install the long zoom lens with the four screws using a hexago head screwdriver supplied with it.  
Ensure that the arrow of the "UPPER" mark on the seal is placed up.

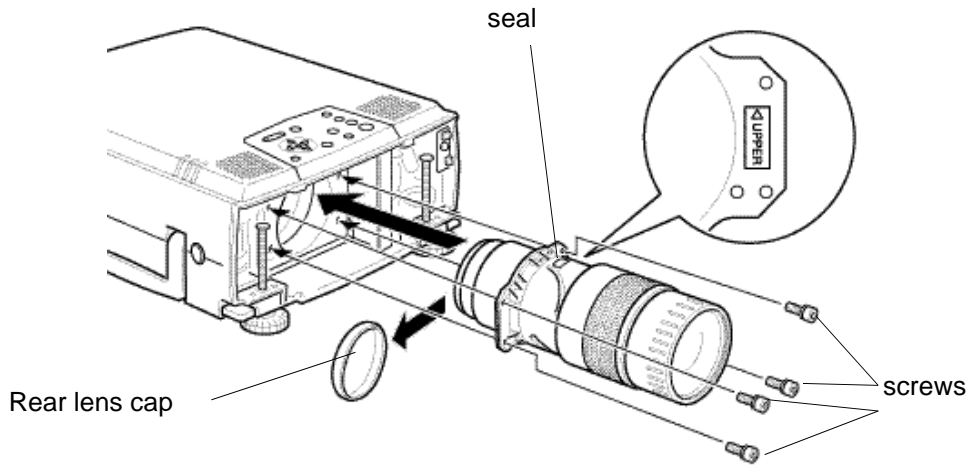

- (5) Set the front case, and secure it with two screws.

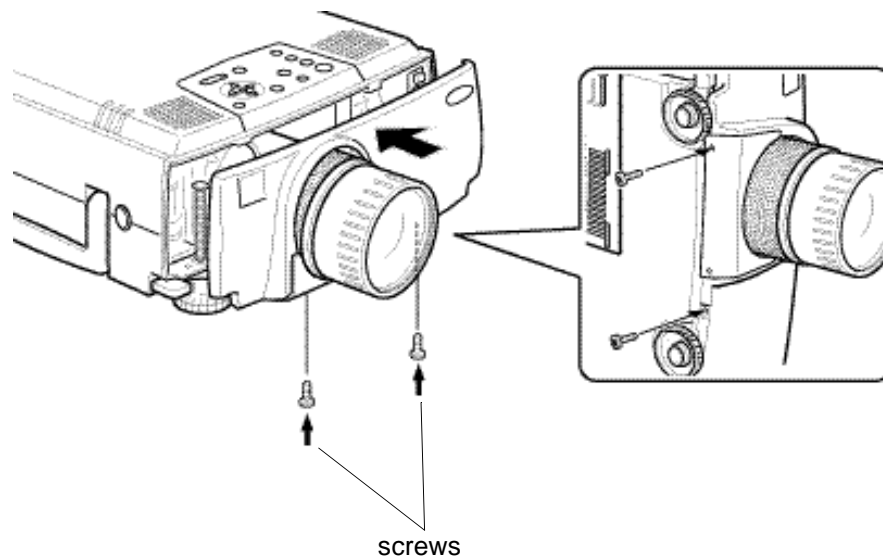

- (6) After replacing the lens is completed, checking that the projector operates properly as referring to the section ["Checking that the projector is operational"](#) .

## 2-1-4. When using the wide conversion lens (ELPCW01)

The wide conversion lens can be used by fitting it to the standard lens.

The projection distance when this lens is used is shorter than when the standard lens is used.

We recommend that the projection distance between the projector and the screen is set to 0.9 m to 12.6m at installation. The following table shows the guidelines to adjust to the correct distance.

Screen size (cm)	Approximate Projector Distance (m) EMP-7350/7250/5350
300inch(610x457)	9.5-12.6
200inch(416x305)	6.3-8.4
100inch(203x152)	3.1-4.2
80inch(163x122)	2.5-3.3
60inch(122x91)	1.9-2.5
40inch(81x61)	1.2-1.6
30inch(61x41)	0.9-1.1
23inch(47x35)	0.9

\* If a screen size other than those shown above is used, determine the correct distance between the projector and the screen according to the following expression.

Maximum screen size(cm)=0.795 X Projector to screen(cm) + 6.670

Minimum screen size(cm)=0.600 X Projector to screen(cm) + 4.437

Maximum Projector to screen(cm) =1.666 X screen size(cm) - 1.145

Minimum Projector to screen(cm) =1.258 X screen size(cm) - 1.300



## 2-1-5. When using the wide zoom lens ELPLW01 (optional)

### <ELP-8000/ELP-9000>

The screen image in the maximum zoom in mode is projected at a size 1.2 times larger than that in the minimum zoom in mode as an 1.2:1 zoom lens is fitted as optional.

We recommend that the projection distance between the projector and the screen is set to 1.7 m to 6.8 m at installation. The following table shows the guidelines to adjust to the correct distance.

Screen size (cm)	Approximate Projector Distance (m)		Dimension A (see fig. below) (cm)
	Wide	Tele	
200inch(406x305)	10.4	17.6	0-153
100inch(203x152)	5.1	8.7	0-76
80inch(163x122)	4.1	6.9	0-61
60inch(122x91)	-	5.1	0-46

\* If a screen size other than those shown above is used, determine the correct distance between the projector and the screen according to the following expression.

Maximum screen size(cm)=0.876 X Projector to screen(cm) + 9.634

Minimum screen size(cm)=0.730 X Projector to screen(cm) + 7.694

Maximum Projector to screen(cm) =1.142 X screen size(cm) - 1.705

Minimum Projector to screen(cm) =1.369 X screen size(cm) - 1.633

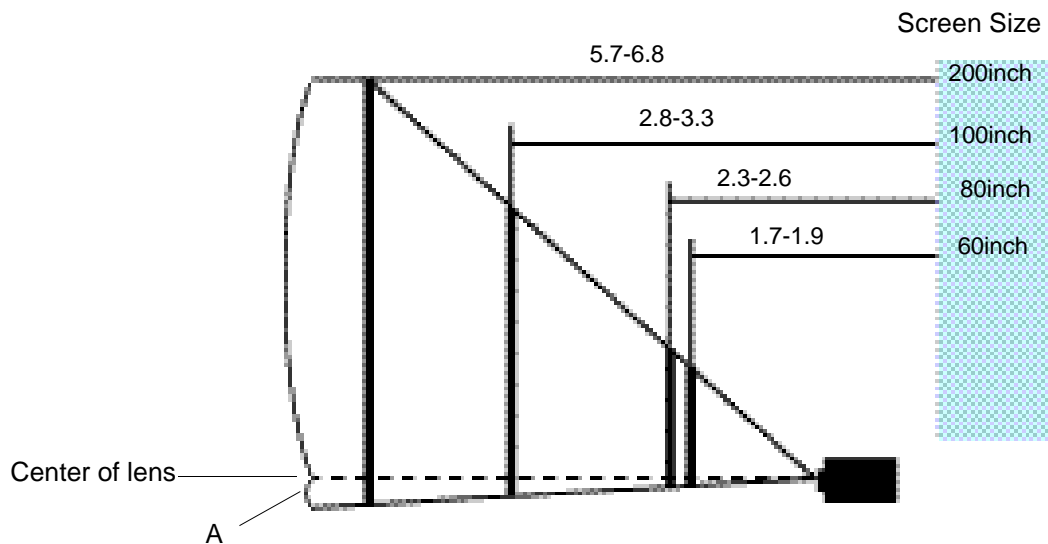

<Model EMP-7350/7250, PowerLite 7350/7250>

 **Warning**

- Be sure to screw the wide conversion lens and adapter ring down completely. Unless they are securely screwed on, they could fall off and cause damage or injury (especially when the projector is ceiling-mounted).

- (1) Remove the rear lens cap.
- (2) Screw the wide conversion lens into the standard lens.
- (3) Rotate it in the direction of the arrow below until it is secure.

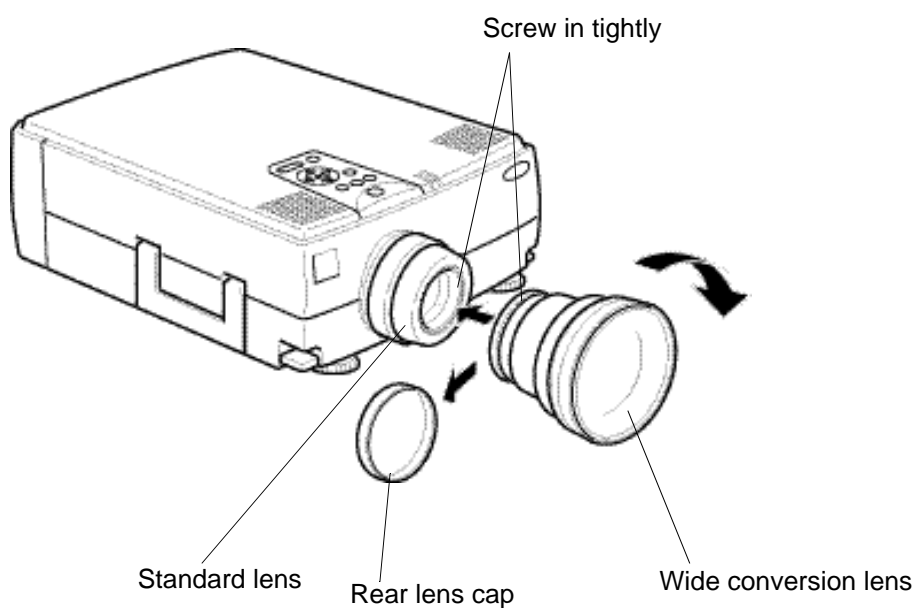

**<Model EMP-5350, PowerLite 5350>**

- (1)Screw the adapter ring into the standard lens.
- (2)Rotate the adapter ring in the direction of the arrow below until it is secure.
- (3)Remove the rear lens cap from the wide conversion lens.
- (4)Screw the wide conversion lens into the adapter ring.
- (5)Rotate it in the direction of the arrow below until it is secure.

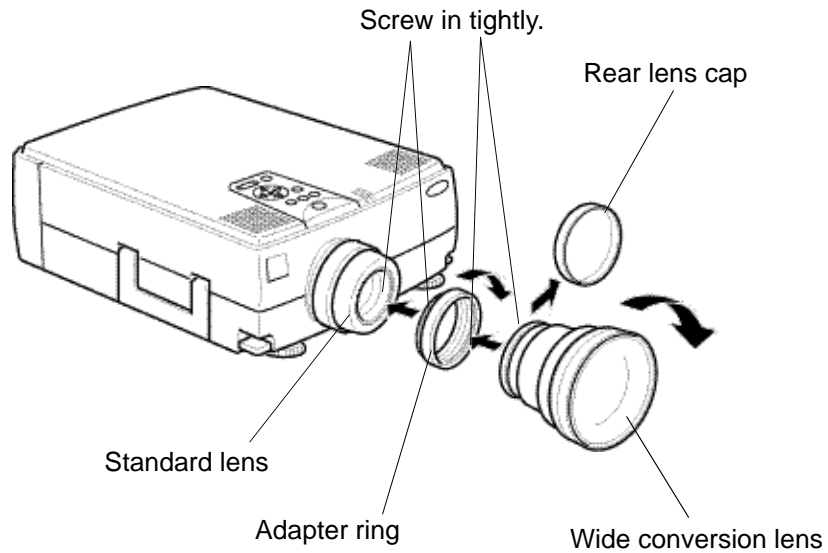

## 2-2.Cabling

### 2-2-1.Connecting to a computer

<Model EMP-7350/EMP-5350/EMP-8000>

#### • Projecting the computer image

The computer cable supplied with the projector can be used to connect to a computer.

#### Note:

- If the projector is located at a distance from a computer, an optional 3 m computer cable ELPKC09 can be used to connect to the computer.
- Except for a computer with the "15-pin micro-D-style" port, an adapter can be used to connect to a computer.
- To connect a Macintosh desktop computer or PowerBook, the MAC monitor adapter supplied with the projector can be used to connect to it.

#### Caution:

- If a universal extension cable is used to connect to a computer, always use a coaxial cable with a coaxial wire for the H Sync and V Sync of the Video signal to avoid an unnecessarily long cabling. The long cabling may cause image noise.
- Never tie the computer cable and power cable together. It may cause malfunction.

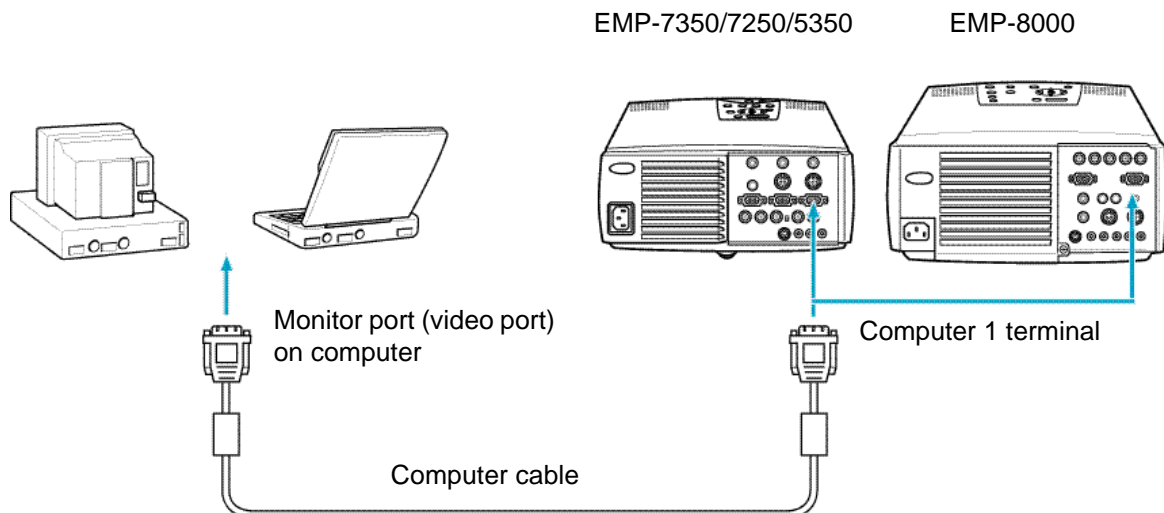

### <Connecting two computers>

In addition to the computer cable supplied with the projector, an optional 1.8 m (ELPKC02) or 3 m (ELPKC09) computer cable is required to connect to a computer.

### Memo

Prepare a cable with the connector at the end of the computer mating to the output terminal of it.

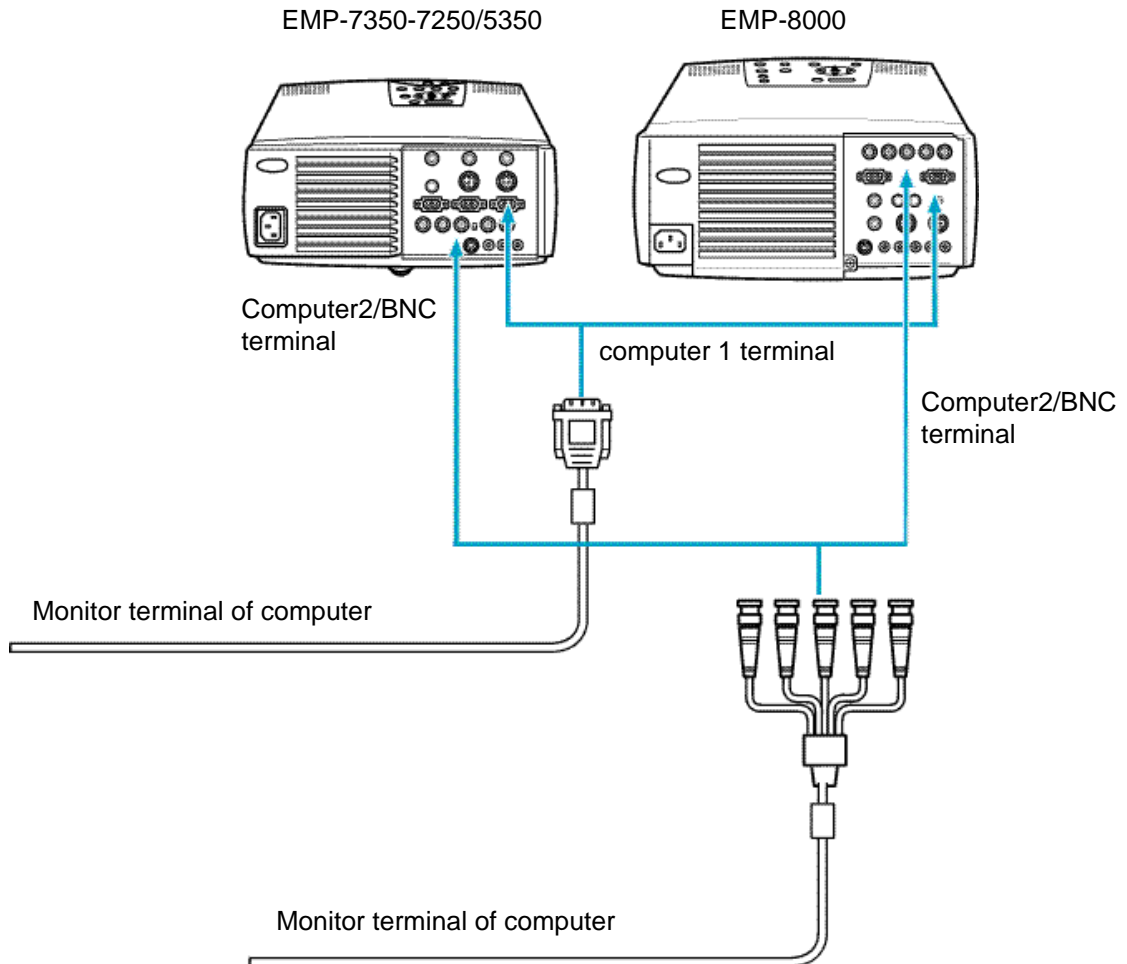

### <Projecting the projector image on a monitor display>

The following figure shows the cable connection to project the projector image on a monitor display.

#### Note:

- Except for a computer with the "15-pin micro-D-style" port, an adapter can be used to connect to a computer.
- To connect a Macintosh desktop computer or PowerBook, the MAC monitor adapter supplied with the projector can be used to connect to it.

#### Caution:

- If the projector is located at a distance from a monitor, a universal extension cable is used to connect to it. Avoid an unnecessarily long cabling. The long cabling may cause image noise.
- Never tie the monitor cable and power cable together. It may cause image noise.

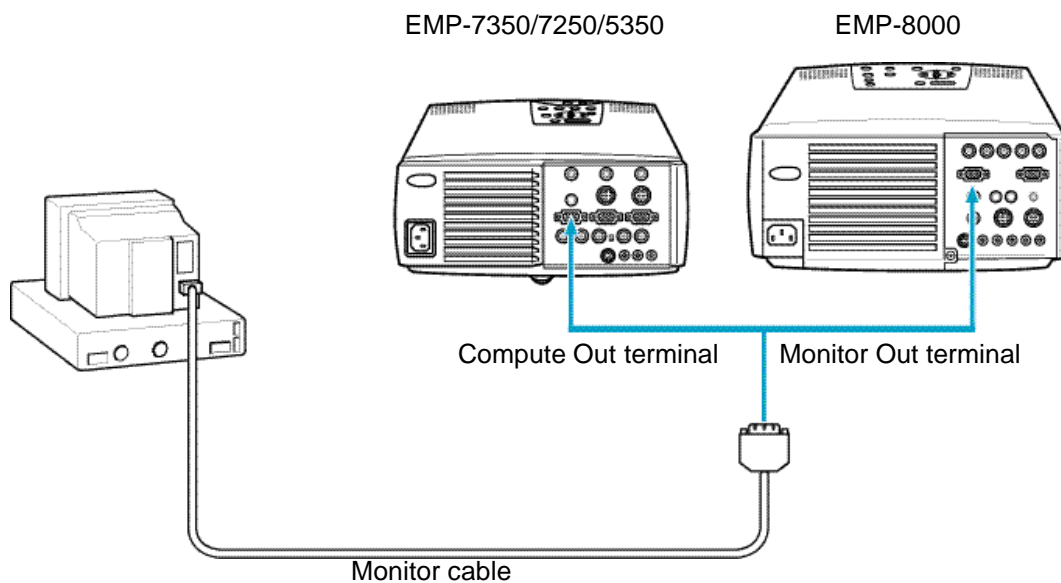

### <Outputting the computer voice from the projector>

An 3W x 2 (output) amplifier is built into the projector.

#### Note:

- If the projector is located at a distance from a computer, a commercially available audio cable (with a 3.5 mm stereo mini plug at the end of projector) can be used to connect to the computer.

#### Caution:

- If a commercially available universal extension cable is used to connect to a computer, install a cabling as short as possible. The unnecessarily long cabling may cause image noise.

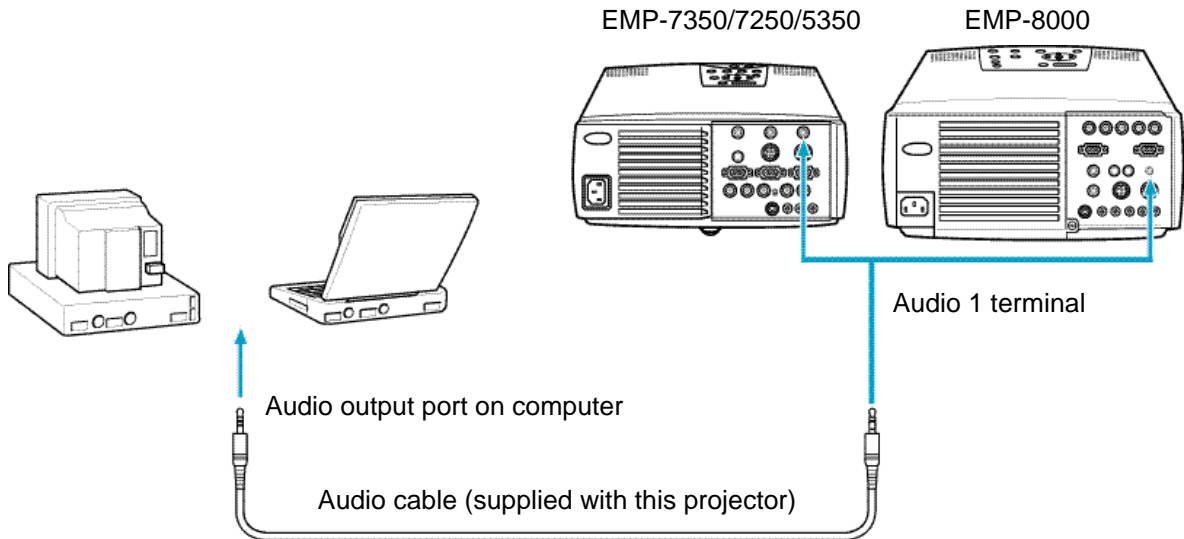

### <Connecting a computer directly to external audio equipment>

The audio output port of the computer can be connected to external output equipment.

#### Note:

- To determine the necessary audio connecting cable, check the types of connection ports on the computer and external audio equipment to be connected.
- Install a cabling as short as possible. The unnecessarily long cabling may cause image noise.

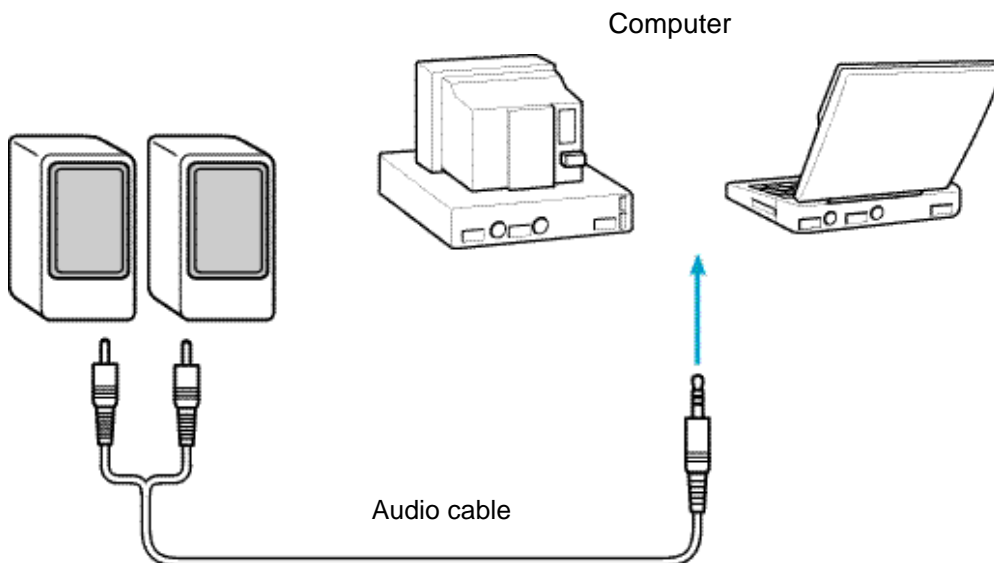

### <Outputting the computer voice input to the projector from external audio equipment>

A commercially available audio cable can be used to output the computer voice from external audio equipment.

#### Note:

- When an audio cable is plugged in the Audio Output terminal on the projector, the computer voice is automatically output to external audio equipment. In this case, no voice is output from the speaker of the projector proper.
- To determine the necessary audio connecting cable, check the type of connection port of the external audio equipment to be connected. A 3.5 mm stereo mini plug can be connected at the end of the projector.
- Install a cabling as short as possible. The unnecessarily long cabling may cause image noise.

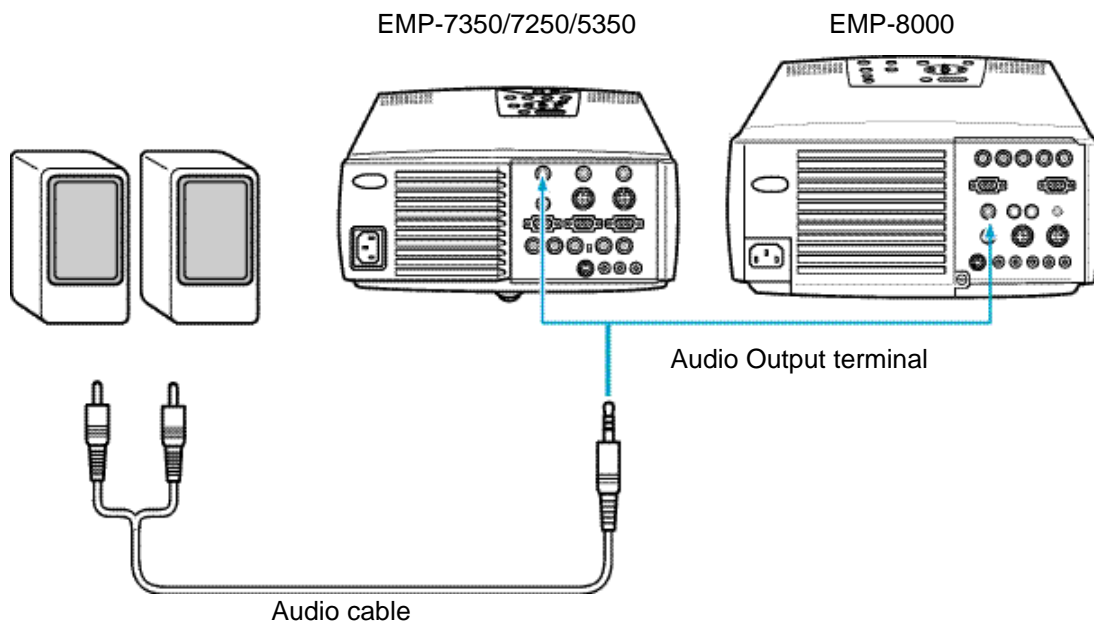



## <Connecting to a workstation>

### Note:

- If the projector is located at a distance from a workstation, a universal extension cable can be used to connect to the workstation. Avoid an unnecessarily long cabling. The unnecessarily long cabling may cause image noise.
- Never tie the EWS cable and power cable together. It may cause image noise.
- To project the computer image using the BNC terminal, make the necessary settings as referring to the section "[Setting the BNC terminal entry mode](#)" described below.

If the workstation has a 13w3 port:

With the projector, an optional 3.0 m (ELPKC12) "13w3-5BNC" cable can be used to connect to a workstation.

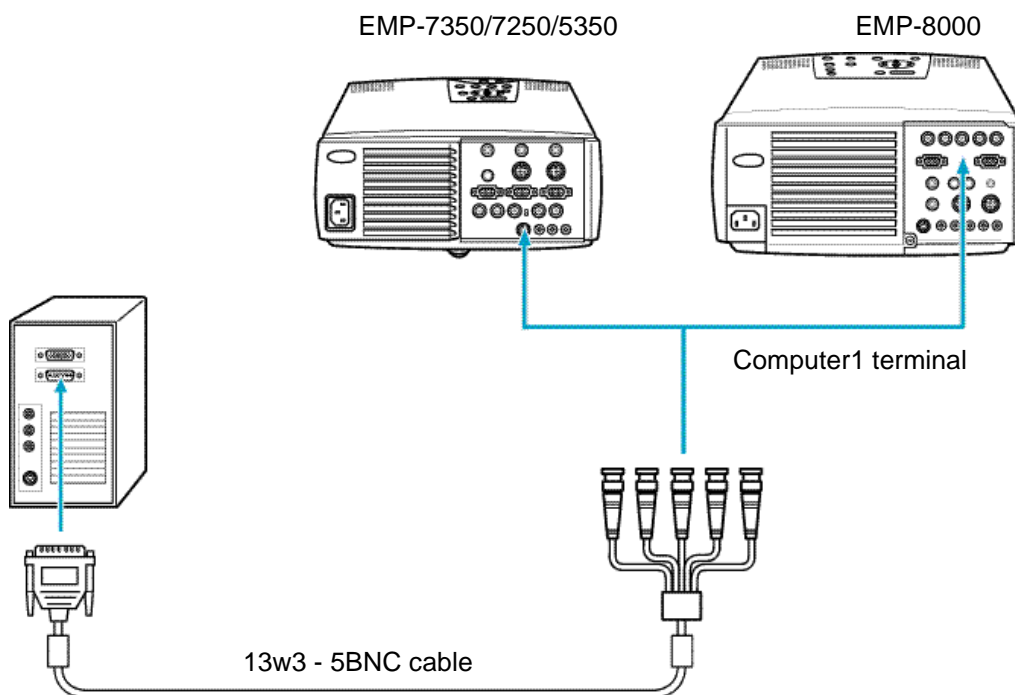

**<If the workstation is a 5BNC port (1):>**

For EMP-7350/7250/5350, a commercially available "15-pin micro-D-style - 5BNC" cable can be used to connect to a workstation.

For EMP-8000, the computer cable supplied with this projector (15-pin micro-D-style - 5BNC) can be used to connect to a workstation.

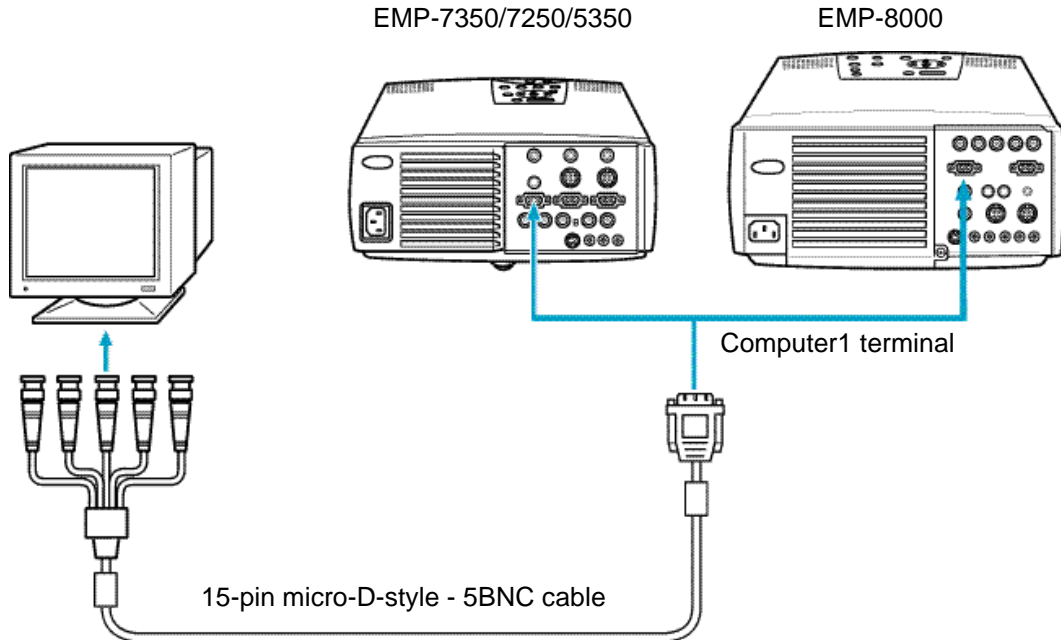

**<If the workstation is a 5BNC port (2):>**

A commercially available "5BNC - 5BNC" cable can be used to connect to a workstation.

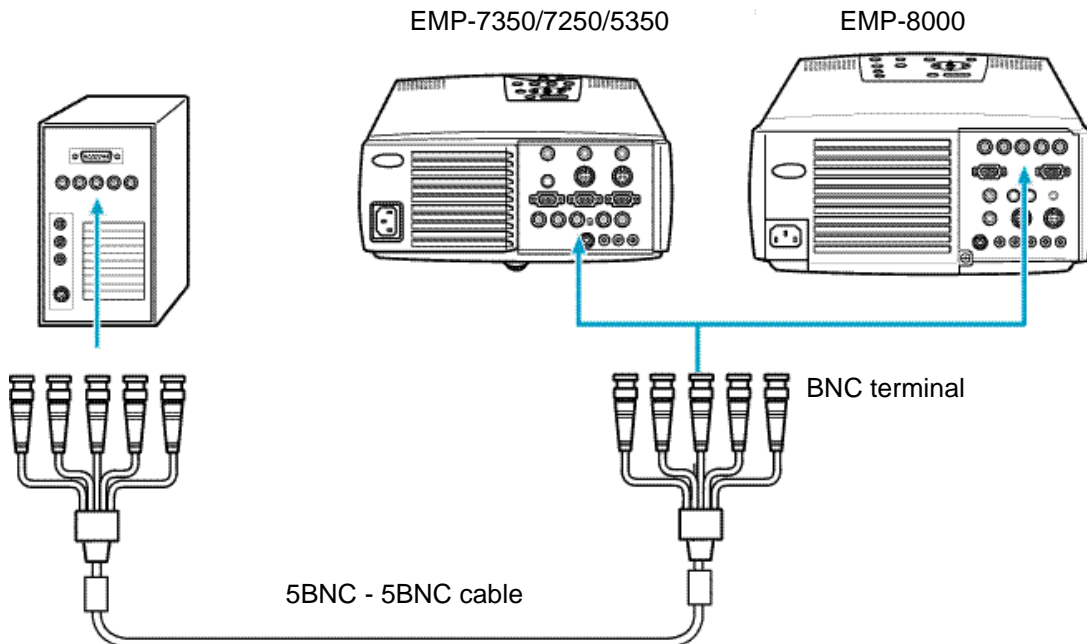

**2-2-2.Connecting to a video source**  
**<Model EMP-7350/EMP-7250/EMP-5350>**

**Note:**

- If the projector is located at a distance from a video source, a universal extension cable can be used to connect to a workstation. Avoid an unnecessarily long cabling. The unnecessarily long cabling may cause image noise.
- Never tie the A/V cable and power cable together. It may cause image noise.
- Inputting the composite video signal

**• Inputting the composite video signal**

The A/V cable supplied with this projector can be used to connect to a video source.

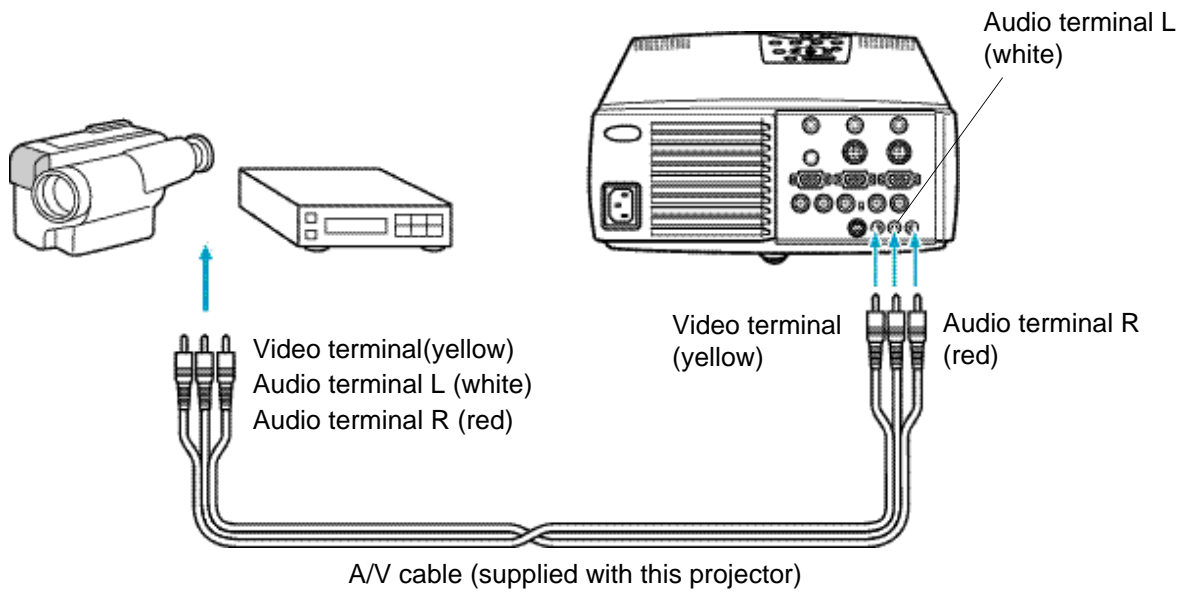

**• Inputting the S-Video signal**

A commercially available S-Video cable can be used to connect to a video source as it is not supplied with the projector.

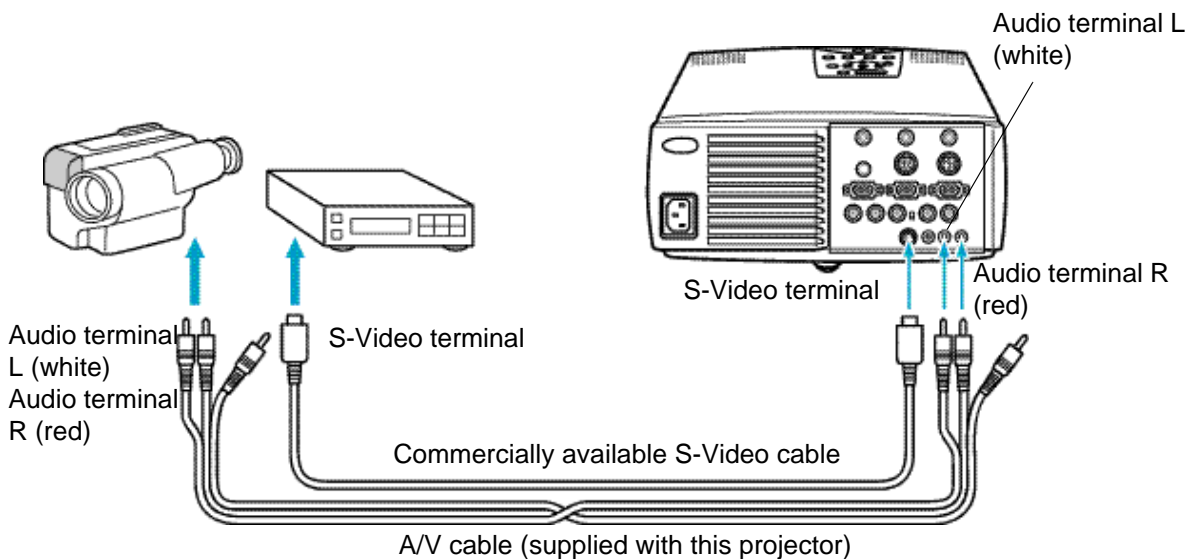

• **Inputting the component (color-difference) video signal**

**Note:**

- Connect the projector to a video source as follows:

Video source	Projector
R-Y	R/R-Y
Y	G-R (G Sync)
B-Y	B/B-Y

- To project the computer image using the BNC terminal, make the necessary settings as referring to the section "[Setting the BNC terminal entry mode](#)" described below.

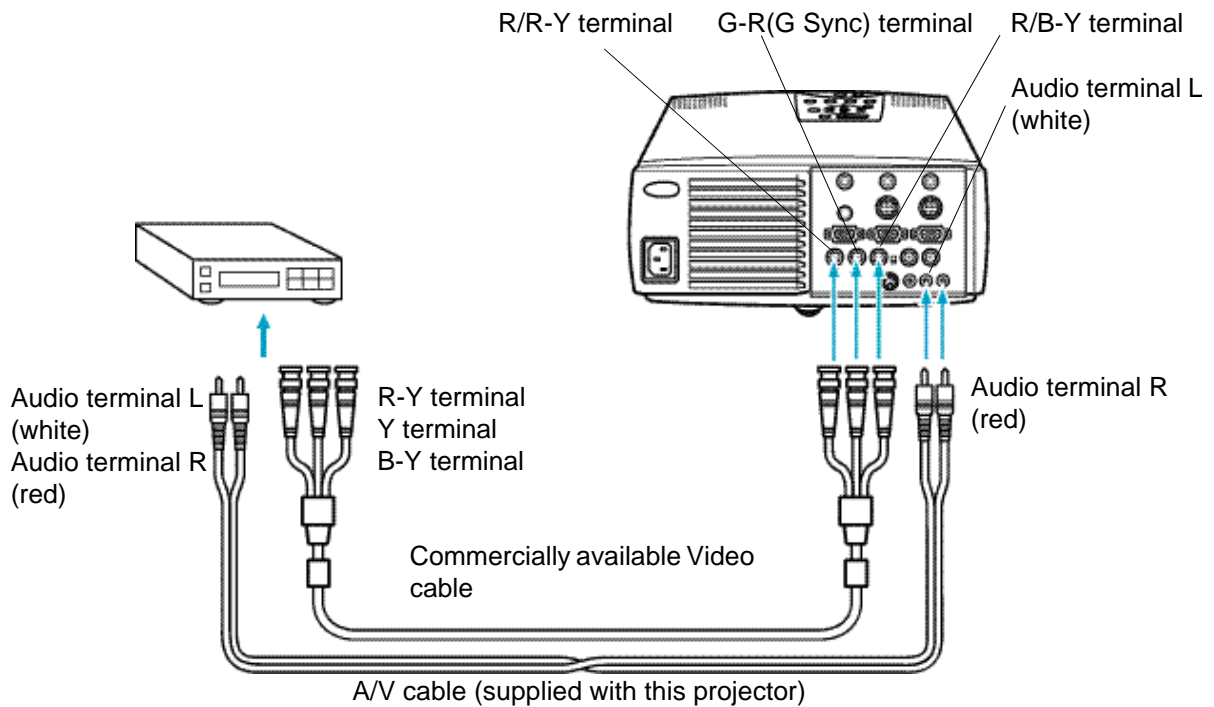

<Model EMP-8000>

• Inputting the composite video signal

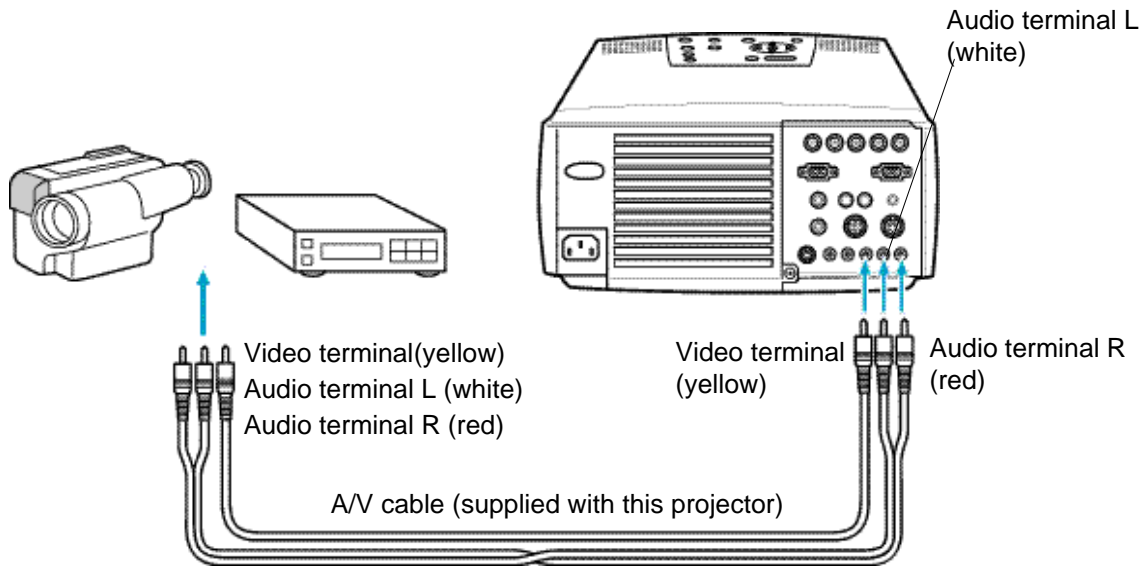

• Inputting the S-Video signal

A commercially available S-Video cable can be used to connect to a video source as it is not supplied with the projector.

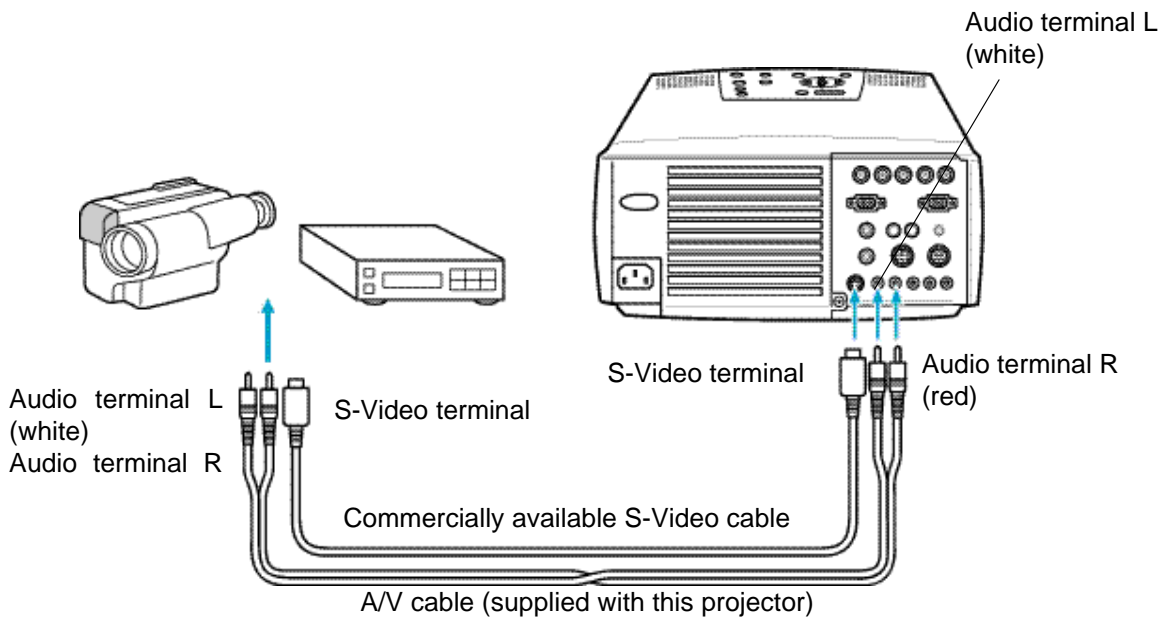

- **Inputting the component (color-difference) video signal**

**Note:**

- Connect the projector to a video source as follows:

Video source	Projector
R-Y	R/R-Y
Y	G-R (G Sync)
B-Y	B/B-Y

- To project the computer image using the BNC terminal, make the necessary settings as referring to the section "[Setting the BNC terminal entry mode](#)" described below.

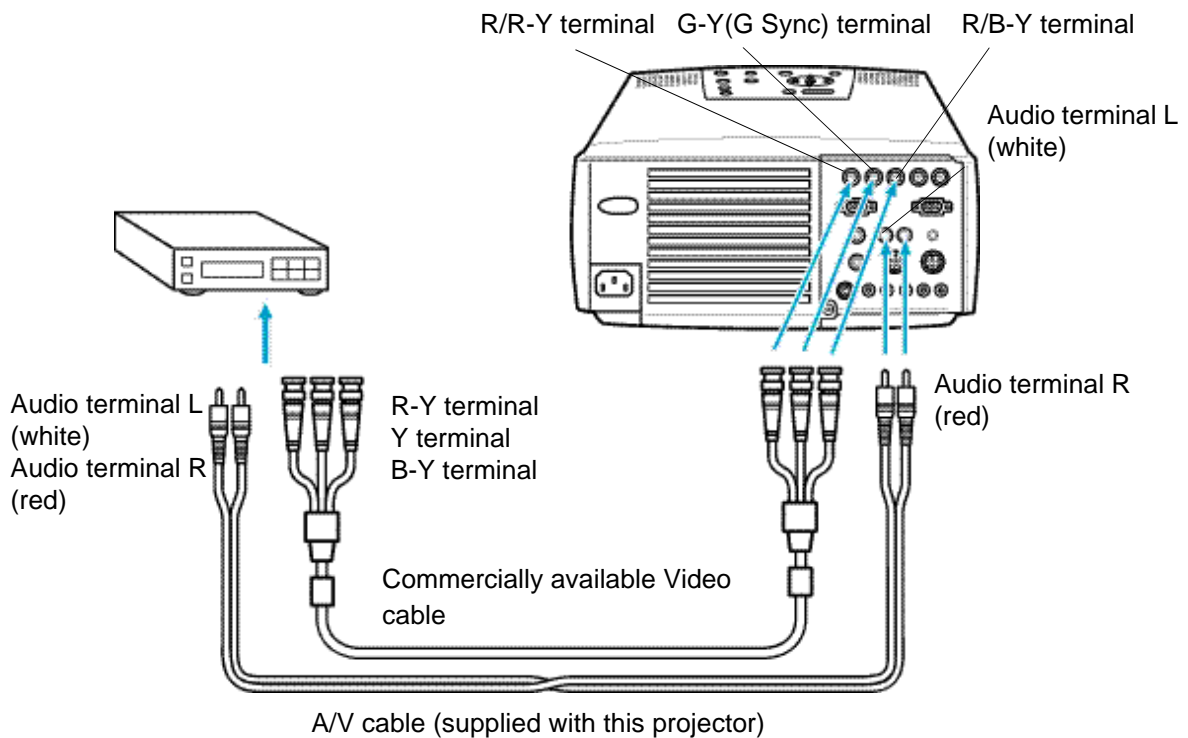

- **Setting the BNC terminal entry mode**

To use the BNC terminal, set the input video signal mode as described below.

- (1) Press [Menu] button to display the Main menu. Press [Sync +, -](control panel) or [Enter](remote control) button on the Main menu to select Setting.

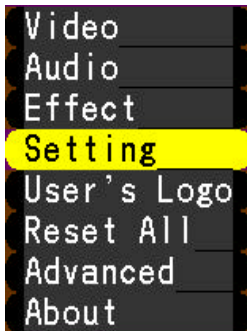

- (2) Press [Enter] (control panel) or [Enter] (remote control). Press [Sync +, -](control panel) or [Enter](remote control) button to select "BNC".

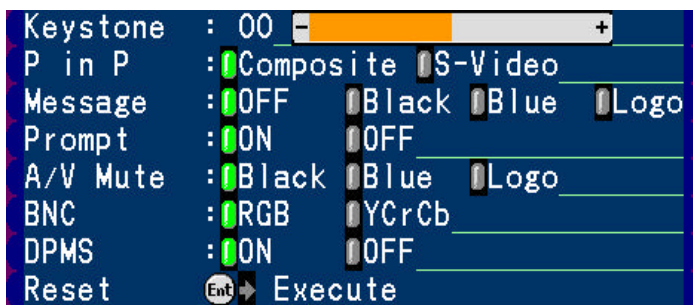

- (3) Press [Tracking +, -] (control panel) or [Enter] (remote control) button to select RGB.



RGB : When the computer signal is used.  
YcrCb : When the video signal is used.

- (4) Press Menu button to close the menu.
- (5) Place the BNC switch of the I/O terminal at the back of the projector to the "BNC" side.
- (6) For EMP-7350/EMP-7250/EMP-5350, place the BNC switch of the I/O terminal at the back of the projector to the "BNC" side.

## 2-3.Mounting Position and Location

- This Ceiling Mount is used to mount Epson Multi-Media Projectors directly on the ceiling.
- The design of the actual product may not be identical to that shown in the illustration.
- Specifications are subject to change without notice.

### Safety Cautions

The warning mark shown below is used throughout this instruction manual to ensure correct usage and to prevent personal injury or property damage. Please read the instructions carefully and understand the contents before proceeding.

#### 2-3-1.Positioning the projector and screen

##### • Positioning the projector and screen

Mount the projector and screen as shown in the figure below.

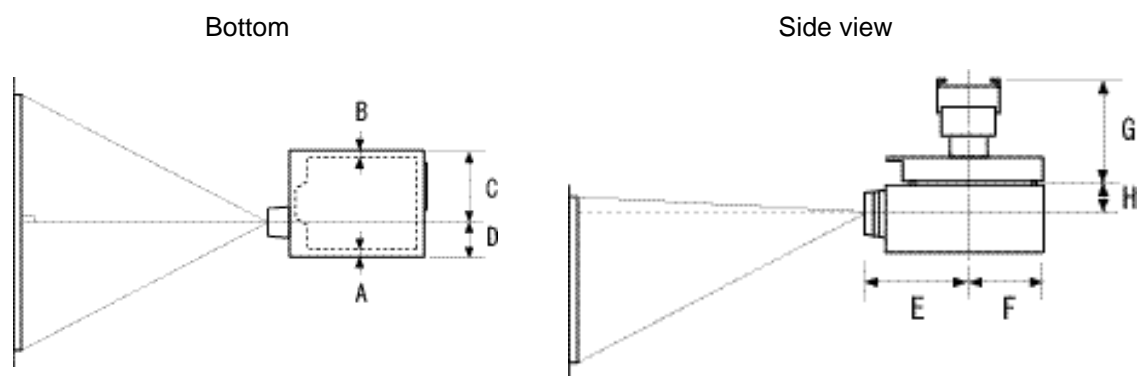

The ideal position is with the projector mounted perpendicular to the screen.

Mount the projector so that the operation switches are on the bottom.

Unit:mm	A	B	C	D	E	F	G	H
EMP-7350 EMP-7250 EMP-5350	10	10	186	114	236	166	213	56
EMP-8000	12	12	185	118	294	181	213	69-79 It can be adjusted with the lens shift function.

\* Dimensions are for reference only and need not be exact.



## 2-3-2.Assembly and Mounting

### • Projector Mounting

- (1) Turn the projector upside down, so that the side with the control switches is facing down.
- (2) Set the projector mounting bracket and tighten using 4 projector lock screws.

Projector is to be mounted with the lens facing the same direction as the longer side of the mounting bracket.

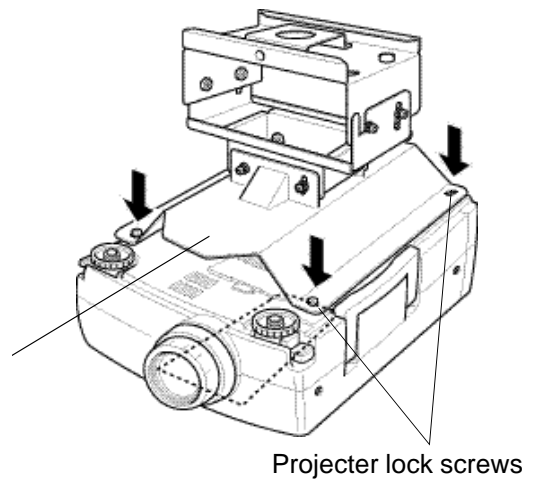

### • Installing on the Ceiling

Fasten the mounting bracket fixture to the ceiling with nuts and bolts that fit the anchor bolt, etc., using the four elongated holes.

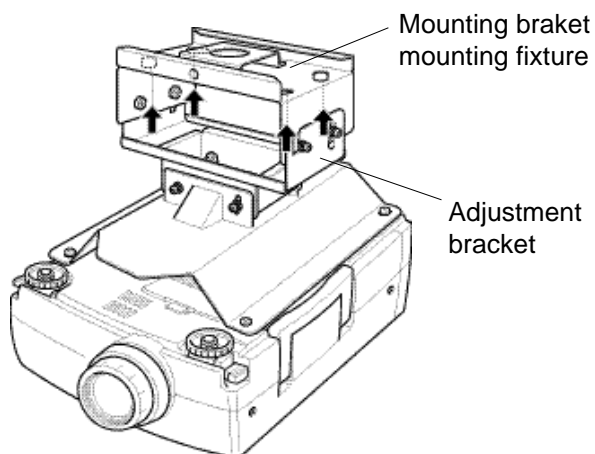

Ceiling contact surface dimensions  
Unit: mm

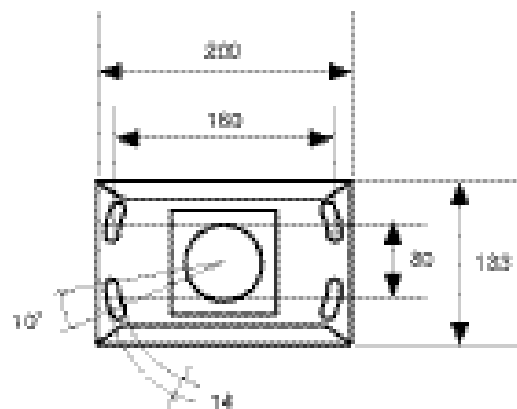

First, mount only the ceiling mounting bracket. Then the assembled adjustment bracket and projector may be installed.

### Warning

- All screws have not been tightened completely at the time of purchase. Tighten all screws completely before installing to ceiling. Failure to do so may result in the unit falling.

## 2-3-3.Adjustment Function

### Warning

- Support from the bottom while adjusting. After adjustment, completely retighten all of the screws. Can result in dropping.

#### (1)Tilt adjustment (adjustable range: approx. 5 degrees up/down)

If the projected image is at an angle on the screen, loosen the tilt adjustment screws then adjust the projector by moving it vertically.

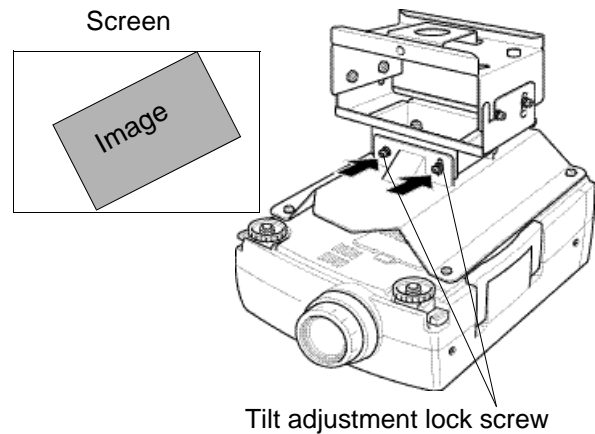

#### (2)Horizontal angle adjustment: (adjustable range: approx. 5 degrees right/left)

If the image is shifted to the left or right in relation to the screen, loosen the mounting bracket fixture screws and adjust by rotating the projector to the left or right.

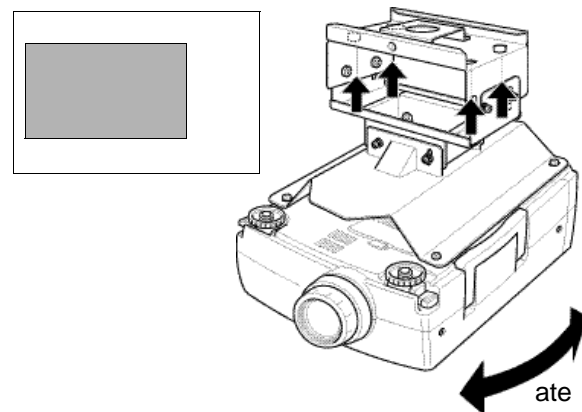

#### (3)Vertical angle adjustment: (adjustable range: approx. 5 degrees up / 10 degrees down)

To move the projected image on the screen vertically, loosen the vertical angle adjustment screws then adjust by turning the unit.

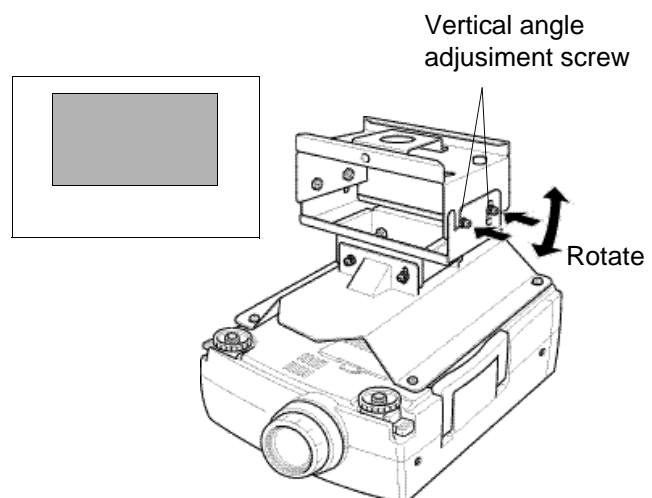

## 2-3-4.Example of mounting to ceiling

- For concrete ceilings

(1) Mount common anchor and bolts (available in stores) to the concrete ceiling.

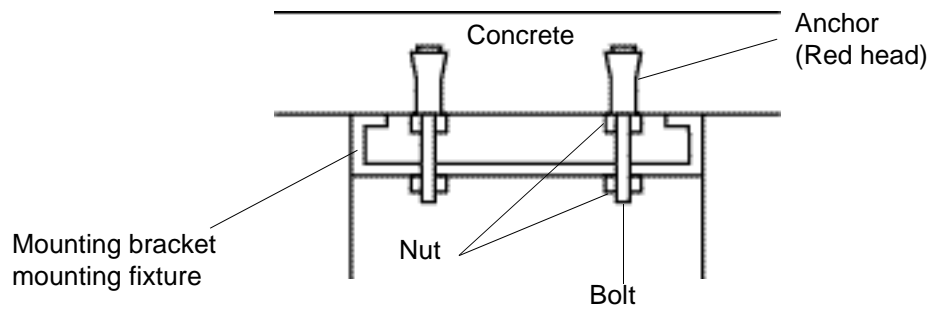

(2) Mount the ceiling mounting bracket using common nuts (available in stores).

- In case there is another layer below the concrete or if mounting cannot be made directly, use the separately sold pipe.

### Warning

- When mounting to ceiling, set parts so that they can withstand the weight of the projector main unit and ceiling mounting bracket, as well as rocking to prevent unit from dropping.
- Epson will not be liable for any accidents occurring from the unit dropping due to improper mounting, etc.

**2-3-5.Ceiling Plate and Pipe Configurations**

**• Ceiling plate configuration**

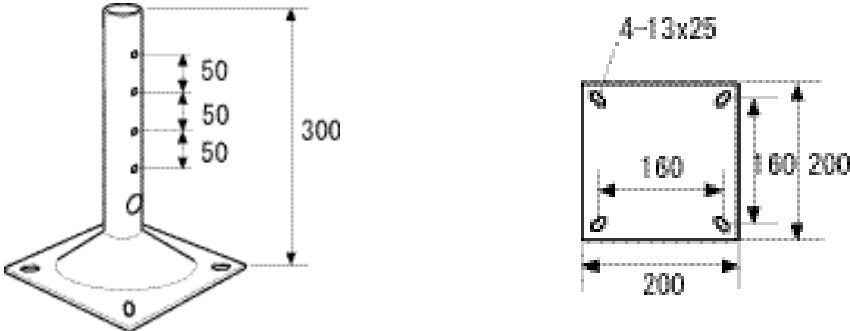

units : mm

**• Pipe configurations**

- L dimension
- Pipe 370(ELPFE01) 370mm
  - Pipe 570(ELPFE02) 570mm
  - Pipe 770(ELPFE03) 770mm

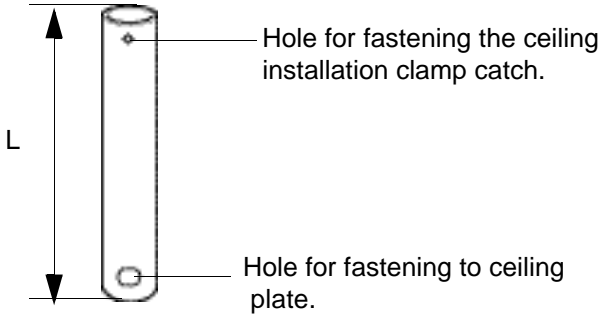

- It is not possible to directly connect two pipes together.

- **Securing the Ceiling Plate to the Ceiling**

Fasten to a structural member with 4 slots (elongated holes) and having sufficient strength in the ceiling.

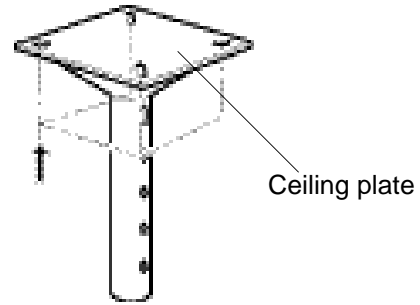

- **Installing the Pipe**

- (1) First of all, set the ornamental cap on the pipe as shown in the drawing. At this point, fasten with the ornamental cap setscrew located below the hole for inserting the pipe thru-hole bolt.
- (2) Next, set the pipe into the ceiling plate and secure by using the pipe thru-hole bolt and pipe set-nut as shown.
- (3) Change the ornamental cap position according to the height of the ceiling and fasten securely with the setscrew.

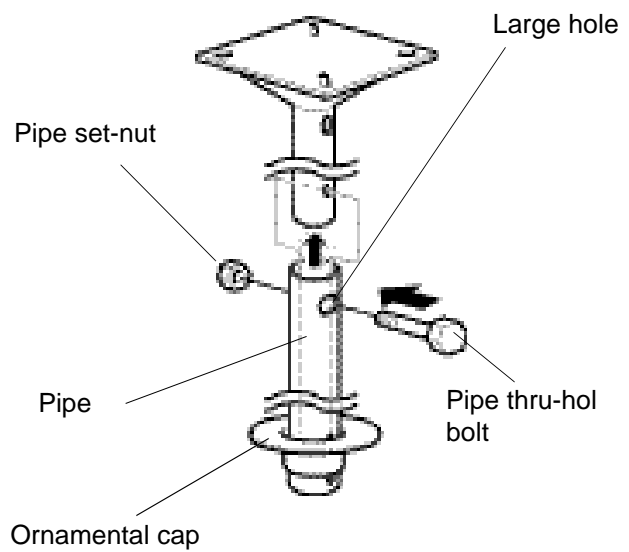

- **Installing to the Ceiling**

<When Attaching to Concrete>

- (1) Drill a hole so the pipe can penetrate the ceiling.
- (2) Fasten the anchors (available in stores) to the concrete as shown in the drawing.
- (3) Fasten the ceiling plate body with the installation bolts (available in stores).

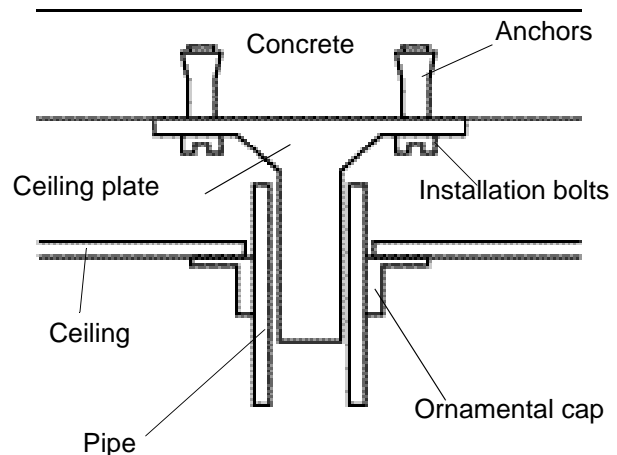

<When Attaching to a Steel Fram>

- (1) Drill a hole so the pipe can penetrate the ceiling.
- (2) Prepare an installation plate that matches the steel frame (see drawing) and secure it to the steel frame as shown.
- (3) Fasten the ceiling plate body to the installation plate with the installation bolts (available in stores).

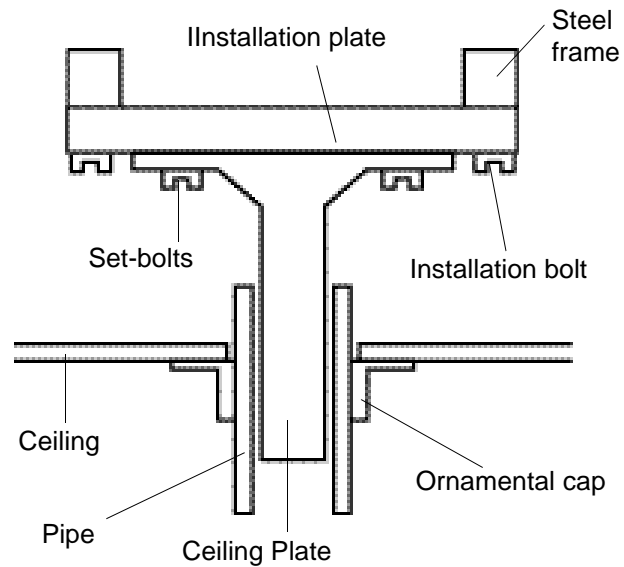

### **WARNING**

- When mounting in the ceiling, install each part so it can withstand the weight of the projector body, ceiling suspension clamps, ceiling plate and pipe weight and also so it withstand side sway. Failure to take this into account may cause the projector and hardware to drop to the floor.
- Our company can bear absolutely no responsibility for accidents, damage or injury due to dropping or falling of equipment due to an installation of insufficient strength.
- This product is not of the rotating type and should never be rotated after the position has been adjusted and the screws tightened.  
Any attempt to rotate can cause the projector to fall. After installation, any change in the direction or angle should be made by a specialist.
- Never loosen any of the bolts, screws or nuts after installation.
- People must never hang from the projector.

## 2-3-6.Using the ceiling mounting bracket fixture and pipe

The projector can also be mounted using the optional ceiling plate and pipe as described below.

### • Installing the Flange

- Assemble the flange and mounting bracket using the dimensions shown in the diagram below.
- Install so that the optical axis of the projector lens is perpendicular to the screen.
- Refer to page 13 and projector for information concerning the distance from the screen.

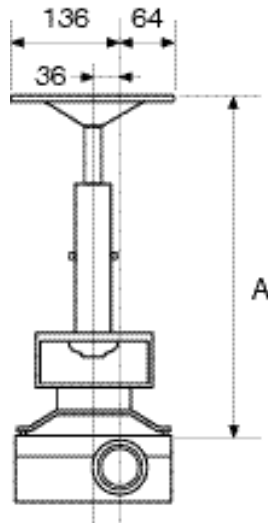

Pipe		A dimension
Pipe370	ELPFP01	600-750
Pipe570	ELPFP02	800-900
Pipe770	ELPFP03	1000-1150

Pipe is adjustable in increments of 50mm.

You can use one of the following 2 methods to set the pipe in the mounting bracket fixture:

1. Set the ceiling mounting bracket onto the pipe after first finishing all assembly of the ceiling mounting bracket and projector, etc.
2. Mount only the ceiling mounting bracket onto the pipe, then assemble all the other components including the projector.

Assemble as follows using either of the above 2 methods.



**Warning:**

- Each part must carry a weight of each of the projector proper, ceiling mount, and ceiling plate and pipe, and withstand lateral vibration adequately. Failure to do so may result in injury due to falling.
- Neither SEIKO EPSON CORPORATION nor its affiliates shall be liable to the purchaser of this product or third parties for damages, losses, costs, or expenses incurred by purchaser or third parties as a result of falling.
- The projector is not rotatable. Never turn the projector after it is adjusted to the proper direction. Rotating the projector can result in injury due to falling. Refer all works including correction to the direction and angle of the projector to your dealer after installation.
- Never loosen bolts, screws, and nuts after the projector is mounted properly.
- Never allow anybody to hang from the projector.

**Fastening the Pipe, and Ceiling Mounting Bracket**

(1) Set the ceiling mounting bracket onto the pipe.

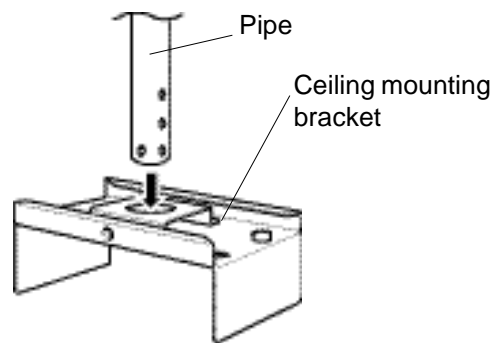

(2) Mount the ceiling mounting bracket catch as shown below and secure with the catch set-bolt and nut.

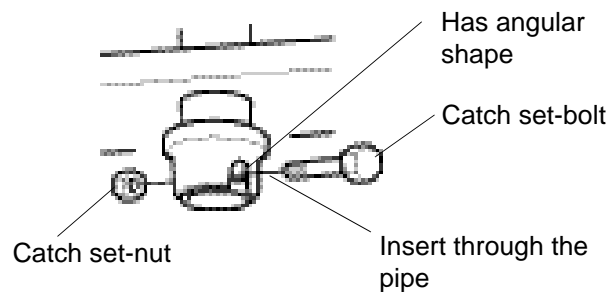
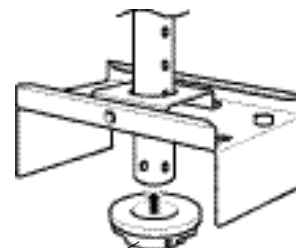



- (3) Lower the ceiling mount fixture onto the ceiling mount fixture catch. Position the projector so that the optical axis of the lens is perpendicular to the screen and tighten the pipe screw.

Pipe lock screw

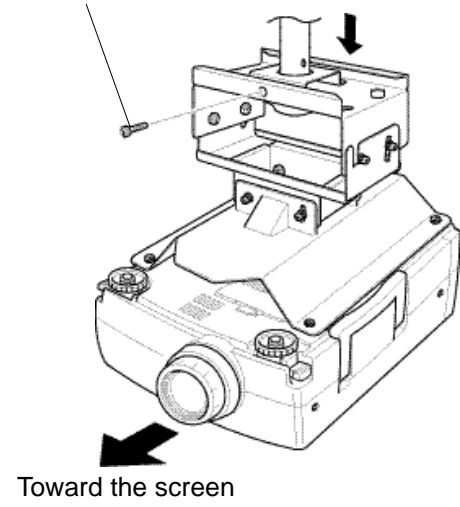

## 2-3-7.Adjustment Function

### Warning

- Support from the bottom while adjusting. After adjustment, completely retighten all of the screws.
- Provide sufficient support when removing the pipe through bolt. Can result in dropping.

#### (1)Horizontal angle adjustment

If the image is shifted to the left or right in relation to the screen, loosen the pipe screw and adjust by rotating to the left or right.

Pipe lock screw

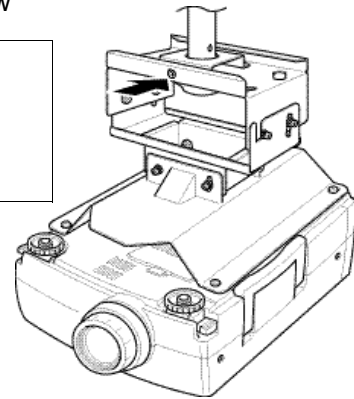

#### (2)Height adjustment

When making large changes in the vertical position of the image on the screen, remove the pipe through bolt and pipe lock nut, and adjust by sliding the pipe. Adjust using the table and drawing shown at right. Use the mounting bracket to fine tune the vertical adjustment and tilt.

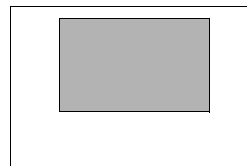

Pipe lock nut

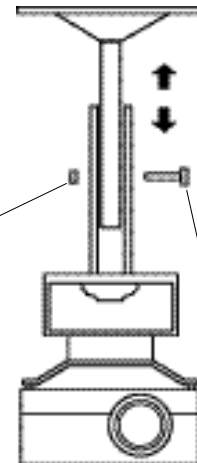

Pipe through bolt

### • Using the ceiling-hung projector

When the projector is hung upside-down from the ceiling, the projected image is mirrored vertically (top-bottom) and horizontally (left-right). Make the necessary settings according to the following steps.

- (1) Press [Menu] button to display the Main menu. Press [Sync +, -] (control panel) or [Enter] (remote control) button on the Main menu to select "Advanced".



- (2) Press [Enter] (control panel) or [Enter] (remote control).
- (3) Press [Sync +, -] (control panel) or [Enter] (remote control) button to select "Ceiling".

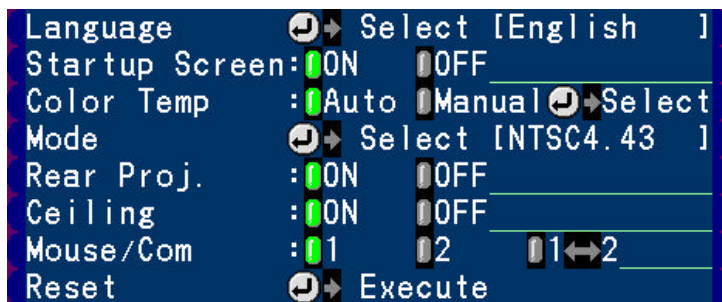

- (4) Press [Tracking +, -] (control panel) or [Enter] (remote control) button to select "ON".



- (5) Press [Menu] button to close the menu.

- **Projecting the image from the behind of the screen using the ceiling-hung projector**

- (1) Press [Menu] button to display the Main menu. Press [Sync +, -] (control panel) or [Enter] (remote control) button on the Main menu to select "Advanced".



- (2) Press [Enter] (control panel) or [Enter] (remote control).
- (3) Press [Sync +, -] (control panel) or [Enter] (remote control) button to select "Rear Proj.".

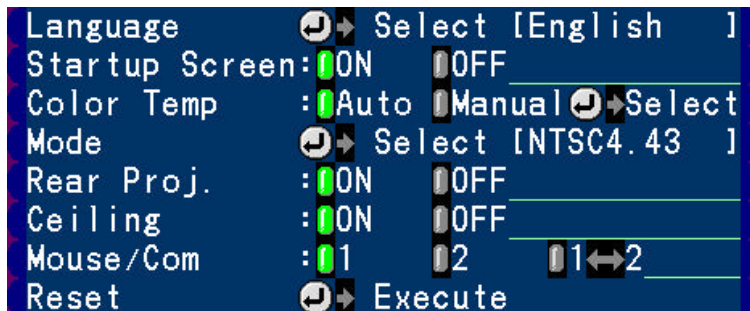

- (4) Press [Tracking +, -] (control panel) or [Enter] (remote control) button to select "ON".



- (5) Press [Menu] button to close the menu.

### 2-3-8. Checking that the projector is operational

- (1) Make the necessary connection to the power supply, computer, and video source.
- (2) Remove the projector lens cap.



#### Caution:

If the projector is used with the lens cap installed, it may be melted due to heat.

- (3) Place the RC ON OFF switch on the remote control to "ON".

#### Note:

If the RC ON OFF switch on the remote control is not placed to "ON", you cannot operate the projector with the remote control.



- (4) Press the Power button on the remote control to turn on the projector.

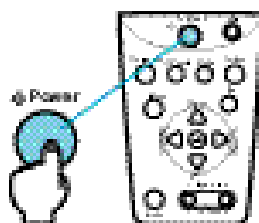

ELP-7350/7250/5350

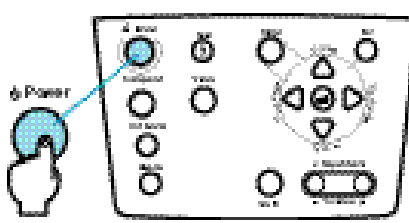

ELP-8000

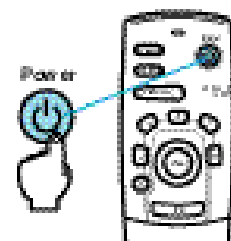

Remote control

- (5) Input the computer or video signal to check that the image is projected properly. If you cannot input the computer or video signal, press [Menu] button to check that the menu displayed is projected properly.

#### Note:

If necessary, check the activation of the projector and functions such as Zoom in and Zoom out.

### **3.Installing the stack multi-screen(Model EMP-8000 only)**

The stack multi-screen can be used to project the image at about double brightness by installing two projectors of the same model vertically and projecting the same image simultaneously.

It uses the stack fitting and the lens shift function provided with EMP-8000.

#### **3-1.The following tips should be kept in mind when you install the stack multi-screen:**

- Projectors of the same model must be used.
- Lenses of the same type must be used.
- The same video sources must be used.
- Projectors must be mounted using the stack kit.  
If they are mounted without the stack kit, the adjustment can not be made easily.
- It is recommended to project the computer image as a stack. However, if the video signal is projected, refer to the section "Projecting the video image as a stack" for details.

## 3-2.Connection for stack projection of the computer image

In case of the stack-connection, the first projector is connected as a master , and the next projector is connected as a slave projector 1. Up to 4 projectors including the master projector can be connected on the stack-connection.

### 3-2-1.If the computer has a 15-pin micro-D-style (BNC) output port

Prepare the necessary number of 15-pin micro-D-style cables for connecting the projectors to be used.

(1)Connect the one end of the 15-pin micro-D-style (BNC) connector to the monitor port of a computer.

#### Note:

- Except for a computer with the "15-pin micro-D-style" port, an adapter supplied with a computer or a commercially available adapter can be used to connect to the computer.
- To connect a Macintosh desktop computer or PowerBook, the MAC disk top adapter and MAC monitor adapter supplied with the projector may be required to connect to it.
- The following illustration shows the cabling using the "15-pin micro-D-style" cable. If the computer has a BNC monitor port, install a cabling as referring to the instruction manual supplied with the computer.
- The cable from the computer can be connected to the BNC on the master projector. In this case, make the necessary settings as referring to the section "Setting the BNC terminal entry mode" described below.

#### Caution:

- If a universal extension cable is used to connect to a computer, always use a coaxial cable with a coaxial wire for the H Sync and V Sync of the Video signal to avoid an unnecessarily long cabling. The long cabling may cause image noise.
- Never tie the computer cable and power cable together. It may cause malfunction.

(2)Connect the other one end of the 15-pin micro-D-style connector to the "Computer1" of the master projector.

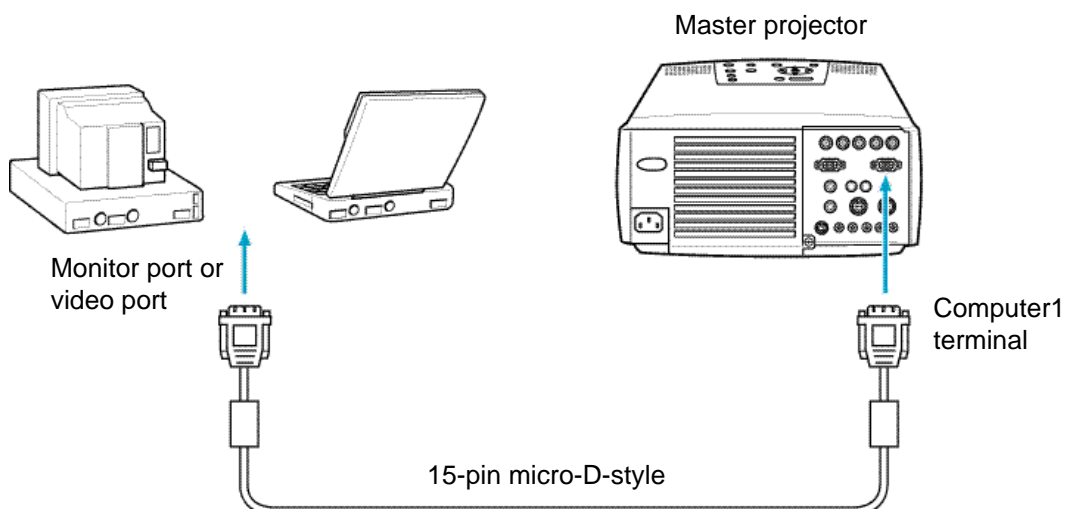

(3) Connect the "Monitor Out" of the master projector to the "Computer1" of the slave projector 1 using the 15-pin micro-D-style cable.

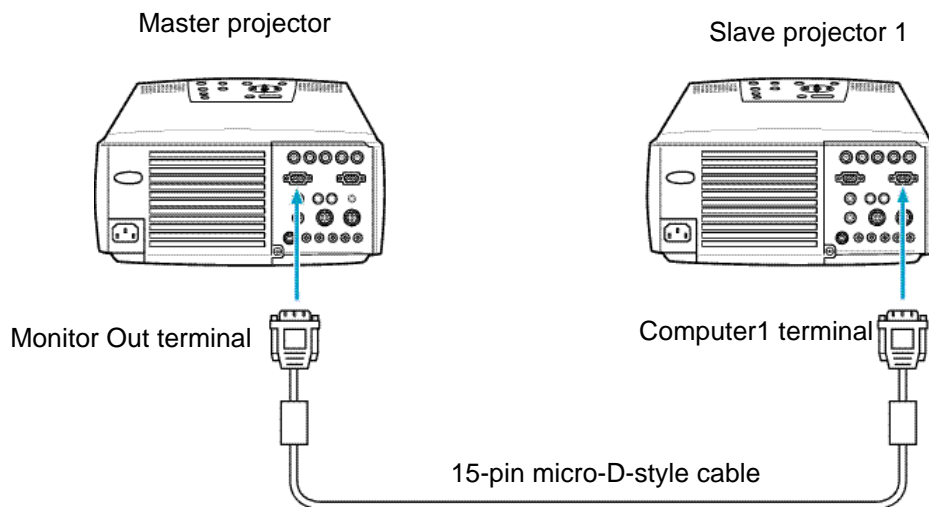

(4) If the slave projector 2 or 3 is used, repeat the step 3.

### Example

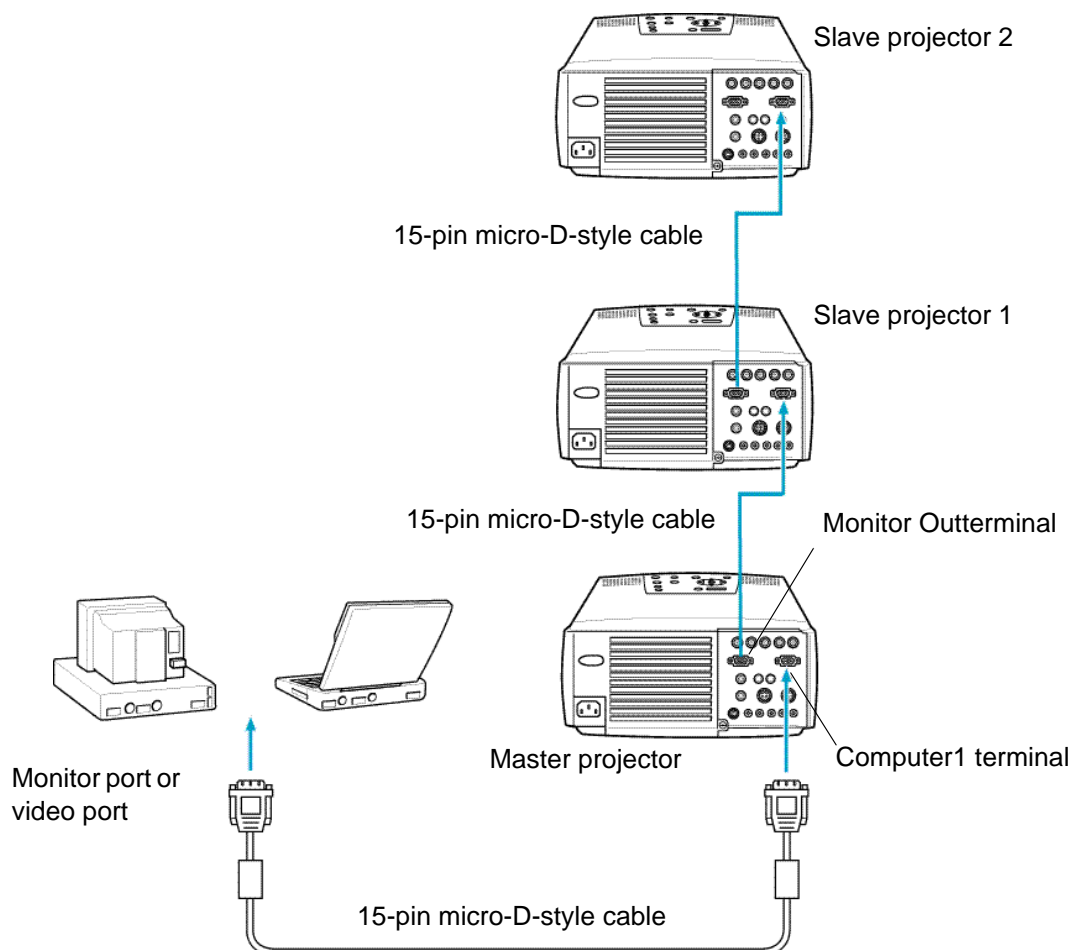



### 3-2-2.Adjustment before stack projection

If two or more projectors are used to project images, it is required to make the necessary adjustment including a superimposing of one image upon another and the color temperature.

#### <Adjusting the color with the test pattern>

The test pattern allows you to adjust the stack position color by projecting it on the screen. To project the test pattern on the screen, a computer with the operating system (OS) of Window95/98/NT4.0 or MAC OS 7.5 or later installed is required.

#### • For Windows users:

- (1) Turn off the projector and computer.
- (2) Turn on the projector, and then turn on the computer again.

#### Note:

- The message "Image signal is not input" is displayed until the video signal is output from the computer side.

This message may not be displayed depending on the settings.

- (3) Press [Computer] (control panel) or [Comp1] or [BNC] (remote control) button to select the terminal connected to the computer of which image is projected. The [Computer] button switches between [Computer1] and [Computer2] every time it is pressed.
- (4) Turn on the computer, and start Windows. Insert the floppy disk labeled "Test Pattern Disk" supplied with the projector in the floppy disk drive.

#### Note:

The test pattern disk includes an application for displaying the color pattern, not for changing the settings such as the display driver.

- (5) Wait for about 15 minutes to stabilize the system for correct adjustment.
- (6) Project the test pattern.
  - <1> Click Start button on the task bar. The popup menu appears. Click Run on the popup menu.
  - <2> Type the drive name and "\TESTPAT.EXE" in half size of character. Click OK button.

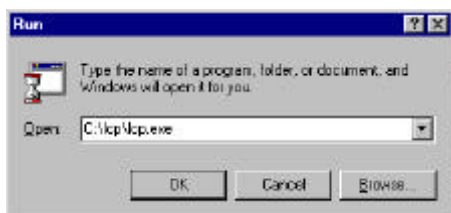

\* The Run dialog box above appears for Windows98 users when the test pattern disk is inserted in the Drive A.

(7) The test pattern is projected after about 20 seconds.

**Note:**

- If you use a monitor with the resolution lower than 1,208 x 1,024 dots, the display of the test pattern is slightly different.
- Move the mouse pointer to the low end of the screen. If the mouse pointer is not located at the required position, the adjustment may not be made properly.
- Similarly, move an item such an icon and tool bar to the low end of the screen if it is displayed.

**Using the lens shift function**

The lens shift function can be used to move the projected image up and down. To use this function, adjust the side position of the projected image with the stack fitting. Then, rotate the lens shift knob to superimpose one image on another.

**Note:**

- The menu can be used to adjust the projection position horizontally and vertically. It is noted that the adjustment can be changed due to the image signals (changes in output mode and display color, etc.) from the computer.
- The stack fitting can be used to adjust a superimposing of one image upon another horizontally.

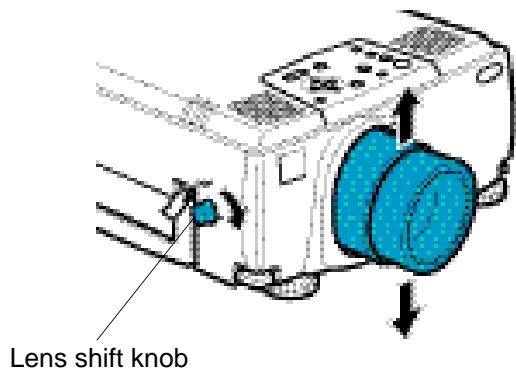

• **Color setting**

If two projectors are mounted with the stack, set the color temperature, and black and white levels so that they provide the same color temperature.

- (1) Press [Menu] button to display the Main menu. Press [Sync +, -] (control panel) or [Enter] (remote control) button on the Main menu to select "Advanced".



- (2) Press [Enter] (control panel) or [Enter] (remote control). Press [Menu] button. Press [Sync +, -] (control panel) or [Enter] (remote control) button to select "Color Temp.".

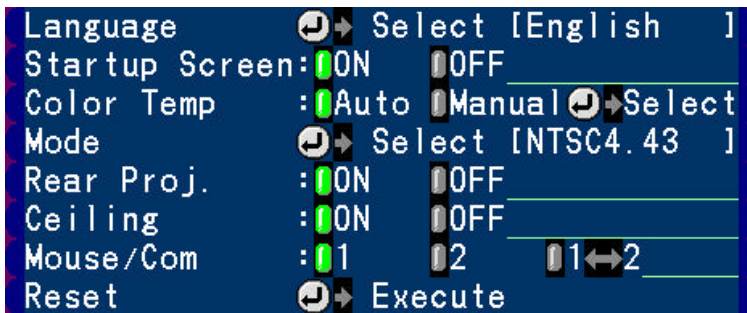

- (3) Press [Tracking +, -] (control panel) or [Enter] (remote control) button to select "Manual".
  - If "Auto" is selected, the color adjustment is made automatically. Proceed to the step 6



- (4) Press [Enter] (control panel) or [Enter] (remote control).
- (5) Press [Tracking +, -] (control panel) or [Enter] (remote control) button to set the color.

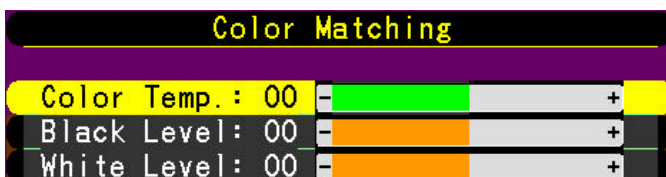

- (6) Press [Menu] button to close the menu.

### 3-3. Operating/controlling the stack-connected projectors

To establish or release the stack-connection, use the "application software ELP-Link IV" which is installed in a computer.

For further information about the installation of ELP-Link IV, refer to the Owner's manual supplied with the projector.

#### 3-3-1. Establishing the stack-connection

(1) Connect the master projector to a computer.

**Caution:**

Extending the main cable for connection may cause malfunction. If extending a cabling, a serial cable must be extended.

- For IBM PC/AT compatible machine (DOS/V PC), NEC PC-98 or compatible machine users
- \* For NEC PC-98 or compatible machine users, an adapter supplied with a computer or a commercially available adapter is required to connect to it.

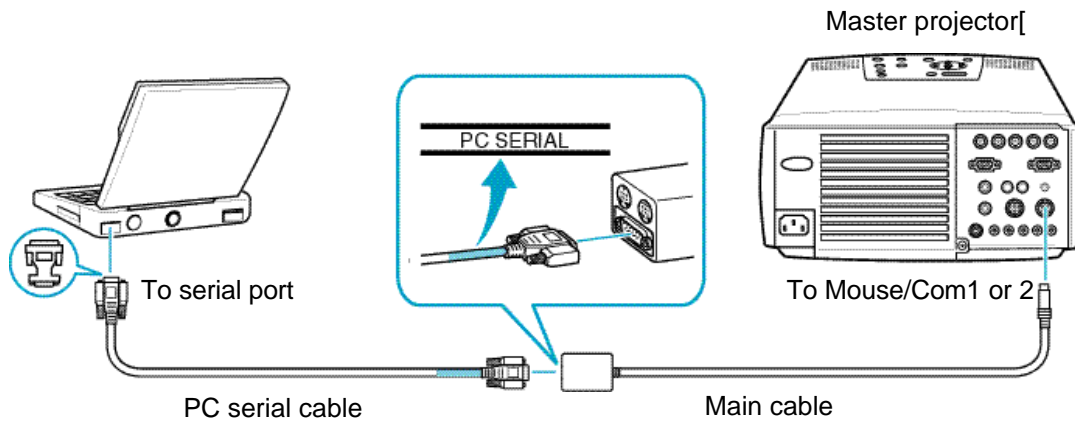

• For Macintosh users:

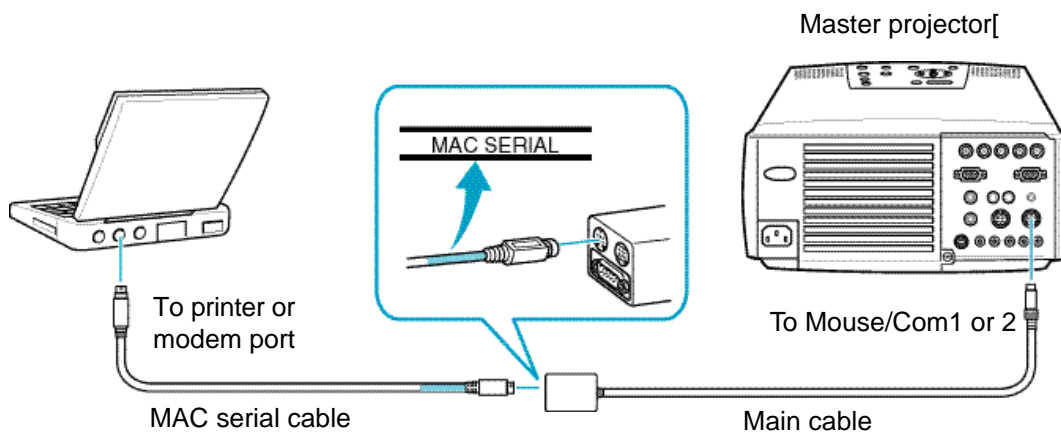

(2) Plug all stack-connected projectors in the wall outlet, place them in the standby mode. (The orange power indicator comes on.)

- (3) Turn on the computer connected to the master projector, and start "ELP-Link IV".
- (4) When "ELP-Link IV" is started, the following window is displayed. Always select "No" on the window.

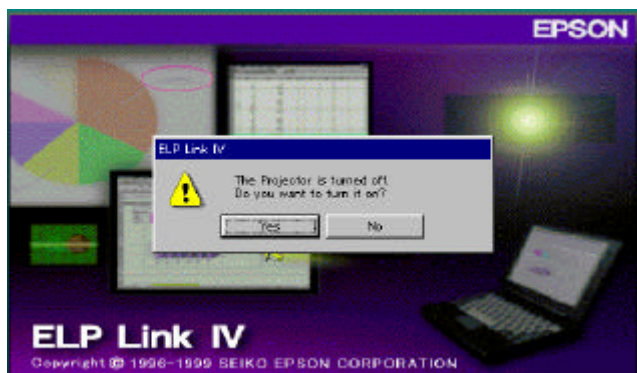

- (5) Select the menu item as follows.
  - For Windows users: Select "About ELP-Link IV" on the pull-down menu appeared by clicking Help.
  - For Macintosh users: Select "About ELP-Link IV" on the pull-down menu appeared by clicking the apple mark "?".



The version information window appears.

- (6) Assign a password as follows.
  - For Windows users: Press [Ctrl] + [I] key.
  - For Macintosh users: Press [Command] + [I] key.

The version information window disappears, and the window to enter a password appears.

- (7) To assign a password, type the password, and click OK button.  
 (A password must be up to 16 alphanumeric characters.)  
 If you do not want to assign a password, just click OK button without any entry.  
 \*No password is entered at installation.

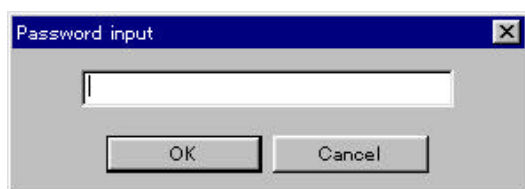

- (8) The Installer specific setting window appears.

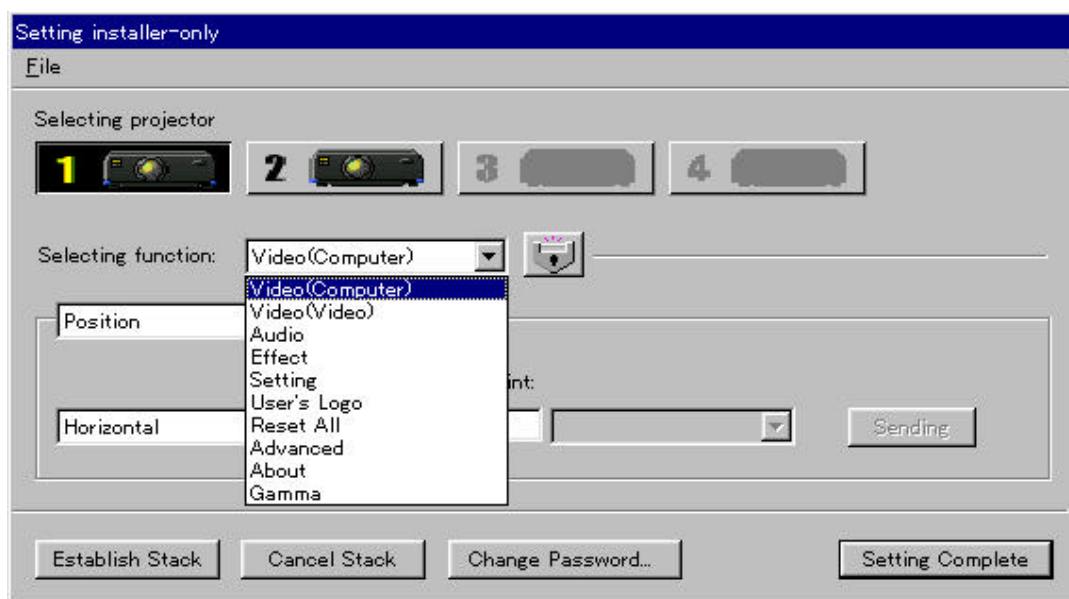
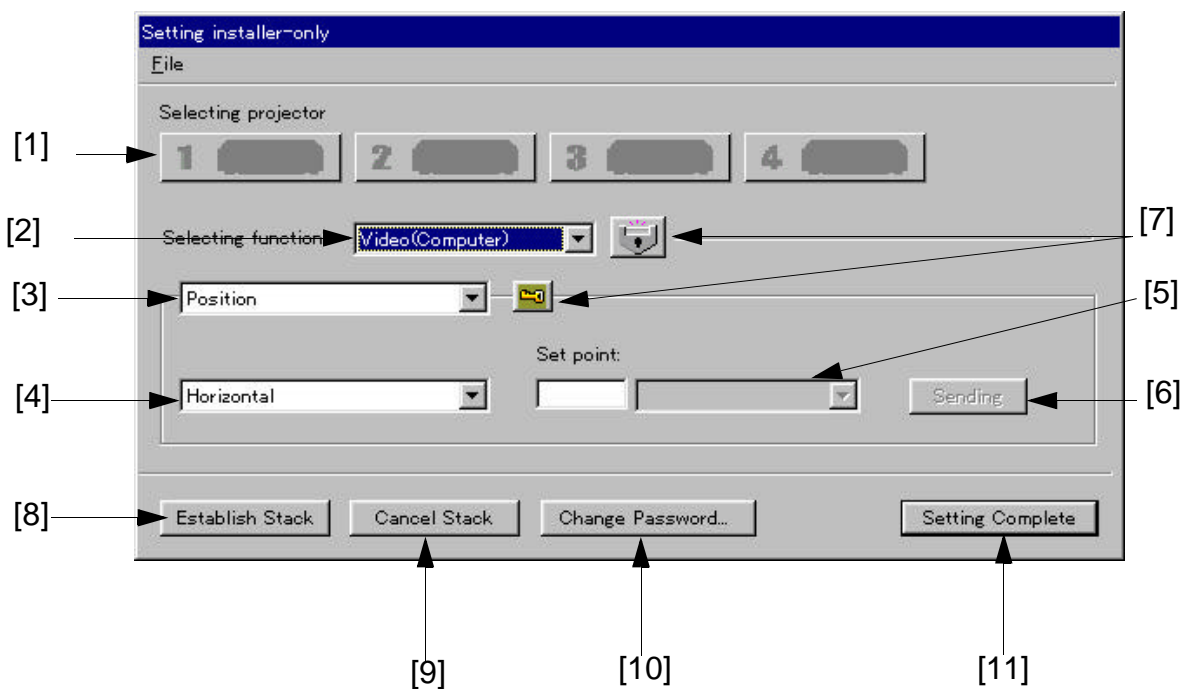

The following table shows the buttons/boxes on the Installer specific setting window and the respective description/function.

Button/box	Description/function
[1]Projector select button	Select a projector to be set. It works in the same manner as with the projector control window. It disables all buttons on projector 1 to 4 on a standalone connection.
[2]Function select combobox (pop-up menu)	Selects a function. Generally, it adapts to the OSD on the projector. The items displayed include Image (computer), Image (video), Audio, Effects, Setting, User logo, and Advanced.
[3]Setting item combobox (pop-up menu)	Changes the function of this control with this box. Generally, it adapts to the OSD on the projector.
[4]Subsetting item combobox (pop-up menu)	This box can be used if there is a menu entry below the setting item. If not, disable this box. It prevents the effects function setting from being changed (only lock/unlock can be possible).
[5]Setting entry area	Consists of the edit box and combobox (pop-up menu). For an numerical setting item, the edit box is enabled. For a selection item, the combobox (pop-up menu) is enabled.
[6]Send button	Sends the setting displayed to the projector after this button is pressed if any value is entered (or selected) in the Setting entry area. It is disabled if not.
[7]Lock/unlock button	Disables all setting items and controls in the group box if clicking the Large key button. It enables them by clicking it again. This button disables the Subsetting item combobox currently displayed (pop-up menu), Setting entry area, and Send button if clicking the Small key button. It enables them by clicking it again. It disables the Initialize all tabs button on the projector control if all initialization is locked. It enables or disables the projector control items of the ELP-LINK IV itself according to the current status.
[8]Stack setup button	Establishes the stack-connection by clicking this button.
[9]Stack release button	Releases the stack-connection by clicking this button.
[10>Password change button	Changes the password to move to the Installer specific setting window. The password change window appears by <a href="#">clicking this button</a> .
[11]Stop setting button	Terminates the Installer specific settings. It returns to the normal projector control window, and enables each item on the function select combobox (pop-up menu) by clicking this button.

(9) Click Stack setup button.

When the stack-connection is established, the window indicating that the stack-connection is made successfully appears.



(10) Click OK button.

### 3-3-2. Operating the stack-connected projectors

When the stack-connection is established successfully, you can operate them using the control panels on the projectors, remote control and ELP-Link IV.

- **Turn on all projectors at a time**

Pressing the Power button on the remote control, or sending the power-on command through ELP-Link IV turns on all stack-connected projectors.

- **Turn off all projectors at a time**

Pressing the Power button on the remote control, or sending the power-off command through ELP-Link IV turns off all stack-connected projectors.

- **Releasing the stack-connected projectors**

Click the ? Stack release button on the ELP-Link IV Installer specific setting window releases all stack-connected projectors, returns them to the standalone connection.

When the projectors are successfully released, the window indicating the stack-connection is released appears.

This function can release the projectors only with the lamp off.

- **Changing the password**

To change the password, enter the old password, new password, and new one for confirmation correctly without any fail.

If any of them is entered incorrectly, the alert message appears, and all edit entries are cleared. A password must be up to 16 alphanumeric characters. If you enter a password using 17 or more characters, it sounds a beep as an error warning.

The password entered is displayed in the form of "\*" in Windows, and "." in Macintosh.



### 3-3-3. Alert message on the Installer specific setting window

The following alert messages are shown on the Installer specific setting window.

For alert messages other than those below, refer to the projector specific or common alert messages.

Alert condition	Alert message	Button
If the stack setup button is pressed, and the stack-connection is established.	Stack-connection is established.	OK
If the stack release button is pressed, and the stack-connection is released.	Stack-connection is released.	OK
If the password is changed successfully.	Password is changed.	OK
If the password is entered incorrectly, or if no password is entered.	Password is incorrect.	OK



### 3-3-4.Using the setting menu

- For Windows users:

A pull-down menu appears by clicking Menu on the Installer specific setting window.

Menu title	Menu item	Status	Description
File (F)	Open (O) Ctrl + O	Enabled	Opens up the file select dialog*1. It can open a projector control file (with a filename extension elp). Opening a file sends the setting (tracking base, lamp on time, PC frequency) to projectors. Sync polarity, preset, and input resolution are excluded. Lock/unlock setting is also sent. While opening a file and changing projector settings, the dialog "Please wait ..." appears.
	Save (S) Ctrl + S	Enabled	Saves the current projector settings. It saves the setting of the projector.
	Save as (A)....	Enabled	Opens up the file select dialog to save the projector settings with a different name. A file with a filename extension elp can be used to save the setting of the projector.

\*1 At default (at the first start-up) the ELP-Link IV install folder is displayed. At the 2nd onward the folder previously selected is displayed.

• **For Macintosh users:**

A pull-down menu appears by clicking Menu on the Installer specific setting window.

Menu title	Menu item	Status	Description
	About ELP-Link IV	Enabled	Indicates version information.
File	New Command + N	Disabled	
	Open Command + O	Enabled	Opens up the file select dialog*1. It can open a projector control file (with a filename extension elp). Opening a file sends the setting (tracking base, lamp on time, PC frequency) to projectors. Sync polarity, preset, and input resolution are excluded. Lock/unlock setting is also sent. While opening a file and changing projector settings, the dialog "Please wait ..." appears.
	Close Command + W	Disabled	
	Save Command + S	Enabled	Saves the current projector settings. It saves the setting of the projector.
	Save as	Enabled	Opens up the file select dialog to save the projector settings with a different name. A projector control file can be used to save the setting of the projector.
	Exit Command + Q	Disabled	
Edit	Cancel Command + Z	Disabled	
	Cut Command + X	Disabled	
	Copy Command + C	Disabled	
	Paste Command + V	Disabled	
	Select All Command + A	Disabled	
Option	Support presentation Command + G	Disabled	
	Open setting window	Disabled	
	Always start under no connection	Disabled	
	Select port for reconnection	Disabled	
	Set test pattern...	Disabled	
Projector	Send user logo	Disabled	
	Send cursor/stamp	Disabled	
Help (OS8 or later)	ELP-Link IV Help	Disabled	

Menu title	Menu item	Status	Description
 (Sysytem7.*)	ELP-Link IV Help		

\*1 Adjust the folder to the setting on the control panel.

### 3-3-5.Operations and restrictions on the stack-connection

Some operations available on the stack-connection are different from those on the standalone connection, and some restrictions are imposed on them.

#### • Operations

Operation	Description
Resize	This operation is performed from the master projector. Then, the slave projectors are displayed against a dark background. However, if using the control panel on the slave projector, it operates individually in the same manner as with the standalone connection.
Menu[	Displays or hide the menu using the Menu button on the remote control. If three projectors are stack-connected, they are activated or deactivated in the following order every time the Menu button is pressed; the master projector activated - slave projector 1 activated - slave projector 2 activated - master projector deactivated ..... However, if using the control panel on the slave projector, it operates individually in the same manner as with the standalone connection.
P In P	Project the computer image as a parent, and the Video image as a child on the screen. However, the slave projectors are displayed against a dark background.
Mute	This operation is performed from the master projector. Then, the slave projectors are displayed against a dark background. However, if using the control panel on the slave projector, it operates individually in the same manner as with the standalone connection.
E-Zoom	This operation is performed from the master projector. Then, the slave projectors are displayed against a dark background.

## 4.Installing the remote control receiver

### 4-1.Installing

The remote control receiver is required if you want to operate the projector at a distance of 10 m or more from it, or if the remote control cannot be pointed towards the remote control sensor on the projector due to impediments.

#### Caution:

- The distance between the remote control receiver and the remote control must be kept within 8 m.
- Do not extend the remote control receiver cord with an extension cord. Extension may cause malfunction.
- Do not place the remote control receiver in an area exposed to direct sunlight or a fluorescent light.

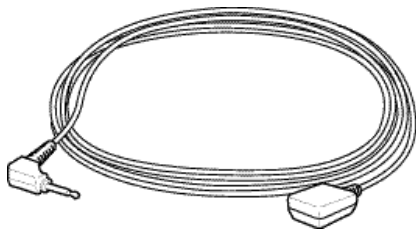

(1) Turn off the projector and computer.

(2) Plug the remote control receiver cord in the "Remote" at the back of the projector.

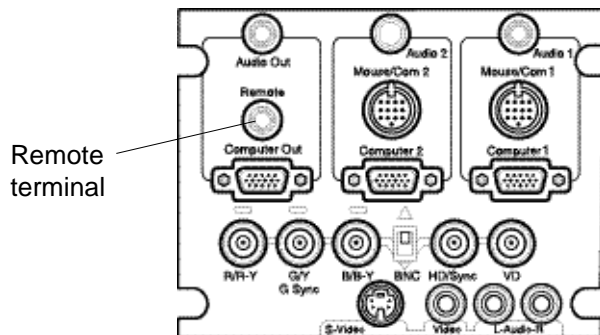

EMP-7350/7250/5350

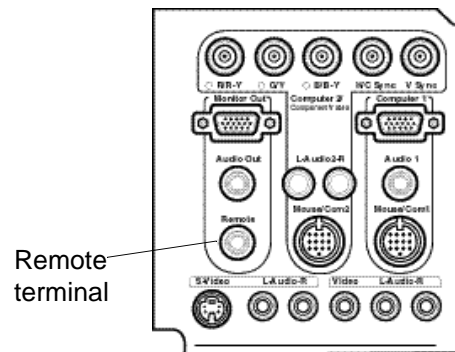

EMP-8000

(3) Place the remote control receiver at a place where it can be operated by the remote control.

## 5.Maintenance



### **Warning:**

- Never open the cabinet of the projector except for your dealer or qualified service personnel. Dangerous electrical voltages inside the projector can cause electric shock.
- Extra special care must be taken on handling the power plug/power connector. Always take the following precautions when handling the power plug and power connector. Failure to do so may result in fire or electric shock.
  - Ensure that the power plug/power connector is free of dust before inserting it into a socket.
  - Ensure that the power plug/power connector is inserted into the socket securely.
  - Do not insert or disconnect the power plug/power connector with wet hands.



### **Caution:**

- Never remove the lamp immediately after turning off the projector.
  - Failure to do so may result in burns or injury.
  - Let the projector cool for about 60 minutes after turning off it. Ensure that the projector is sufficiently cooled down before replacing the lamp.
- Unplug the projector from the wall outlet before cleaning.
  - Failure to do so may result in electric shock.

## 5-1.Replacing the lamp

### Caution

- Insert the lamp and fasten the lamp cover securely to turn on the projector without fail. For safety, the projector turn itself off if the lamp cover is open.

### Note:

- The total lamp usage time is automatically reset to 0 when the lamp is replaced with the new one.
- Replace the air filter with the new one supplied with lamp after replacing the lamp as well.

### 5-1-1.Model EMP-7350/EMP-7250/EMP-5350

Replace the lamp as described below.

Use only replacement lamp part number ELPLP05 (optional).

(1)Turn off the projector. Unplug the power cable from the wall outlet after the projector is cooled down sufficiently.

- The time required to cool down the projector varies with an ambient temperature.

(2)Lift off the lamp cover after the projector is cooled down sufficiently.

- It takes about 60 minutes to cool down the projector sufficiently.
- Use a screwdriver, coin, or similar object to loosen the two retaining screws on the lamp cover.

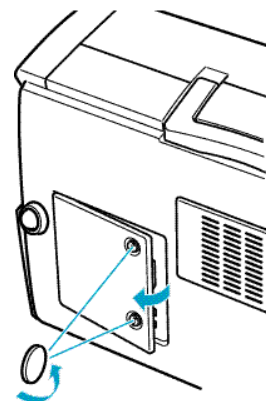

(3)Pull out the lamp.

- Use a screwdriver, coin, or similar object to loosen the two screws holding the lamp in position. Lift up the handle.

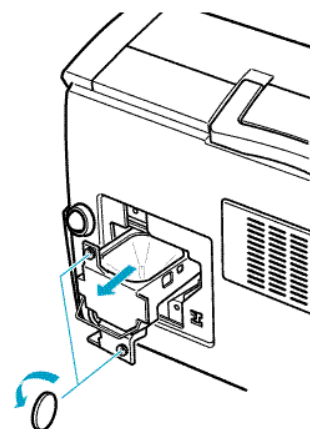

(4) Gently insert the new lamp by lowering it into position.

- Align the lamp, and push it as far as it will go. Use a screwdriver, coin, or similar object to tighten the screws you loosened in step 3.

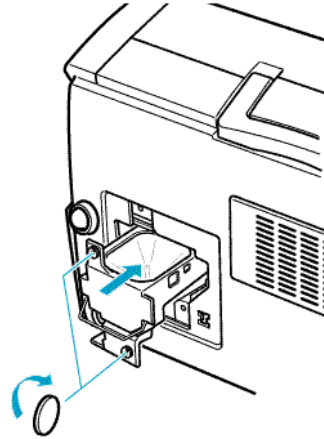

(5) Replace the lamp cover.

- Align the lamp cover, and push it. Use a screwdriver, coin, or similar object to tighten the screws you loosened in step 2.

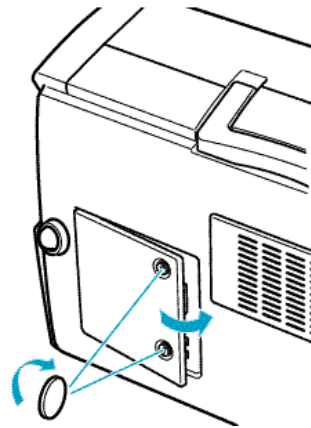



## 5-1-2.Model EMP-8000

Replace the lamp as described below.

Use only replacement lamp part number ELPLP08 (optional).

(1) Turn off the projector. Unplug the power cable from the wall outlet after the projector is cooled down sufficiently.

- The time required to cool down the projector varies with an ambient temperature.

(2) Remove the fan after the projector is cooled down sufficiently.

- It takes about 60 minutes to cool down the projector sufficiently.
- Use a screwdriver supplied with the optional lamp to loosen the two retaining screws on the fan.

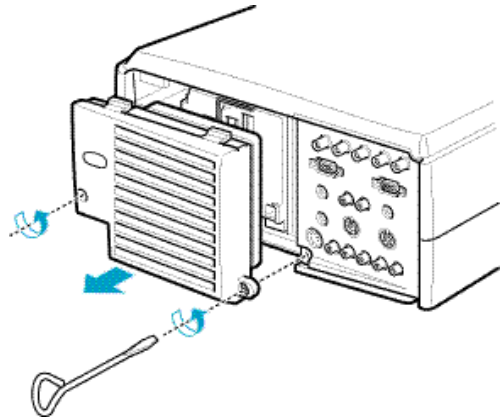

(3) Pull out the lamp.

- Use a screwdriver supplied with the optional lamp to loosen the three screws holding the lamp in position. Lift up the handle.

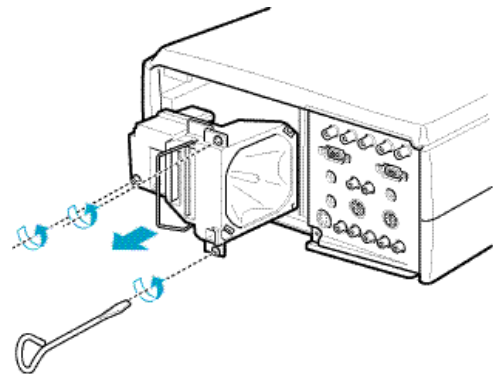

(4) Gently insert the new lamp by lowering it into position.

- Align the lamp, and push it as far as it will go. Use a screwdriver supplied with the optional lamp to tighten the screws you loosened in step 3.

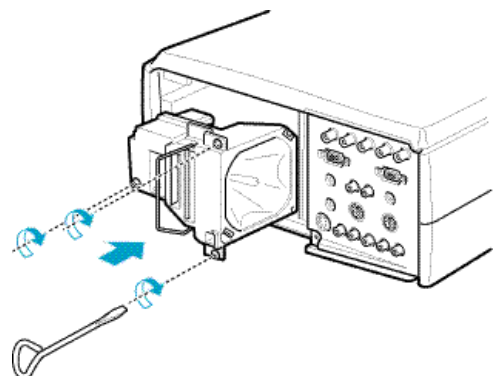

(5) Replace the fan.

- Align the lamp cover, and push it. Use a screwdriver supplied with the optional lamp to tighten the screws you loosened in step 2.

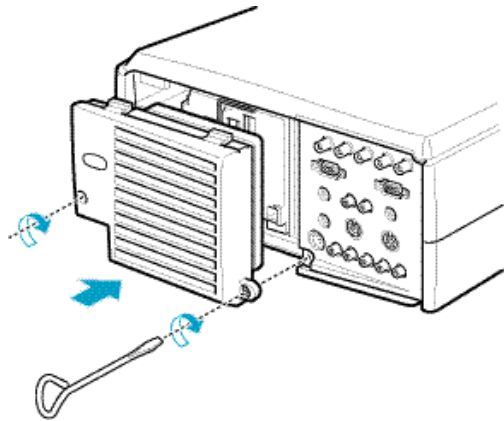

## 5-2.Replacing the air filter

Replace the air filter with the new one supplied with lamp after replacing the lamp as well.

### Caution:

Stand the projector with the handle at the top to prevent dust from entering the projector.

### 5-2-1.Model EMP-7350/EMP-7250/EMP-5350

(1)Turn off the projector. Unplug the power cable from the wall outlet after the projector is cooled down sufficiently.

- The time required to cool down the projector varies with an ambient temperature.

(2)Lift off the air filter cover.

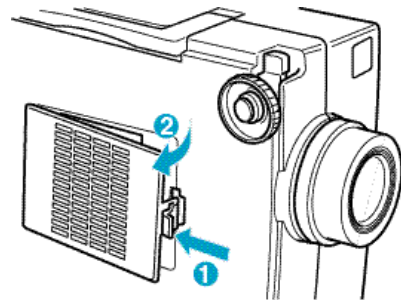

(3)Take out the air filter.

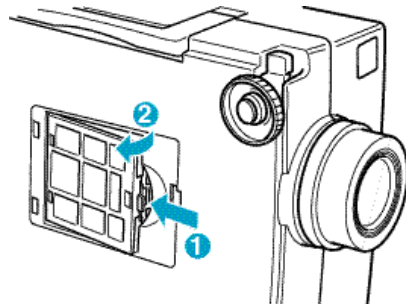

(4)Insert the new air filter.

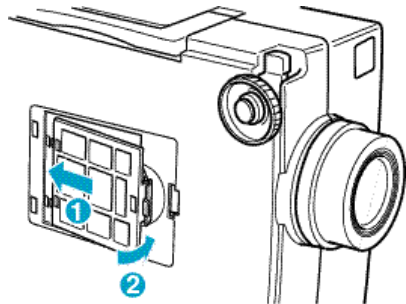

(5)Replace the air filter cover.

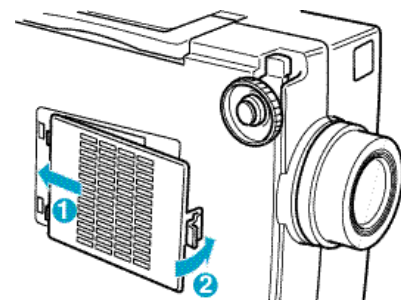

## 5-2-2.Model EMP-8000

(1) Turn off the projector. Unplug the power cable from the wall outlet after the projector is cooled down sufficiently.

- The time required to cool down the projector varies with an ambient temperature.

(2) Lift off the air filter cover.

- \* Stand the projector with the handle at the top to prevent dust from entering the projector.

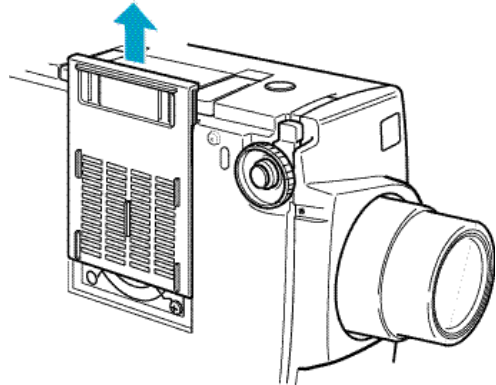

(3) Insert the new air filter.

- \* Replace the filter cover by engaging the retaining lug first, and then pressing the hook.

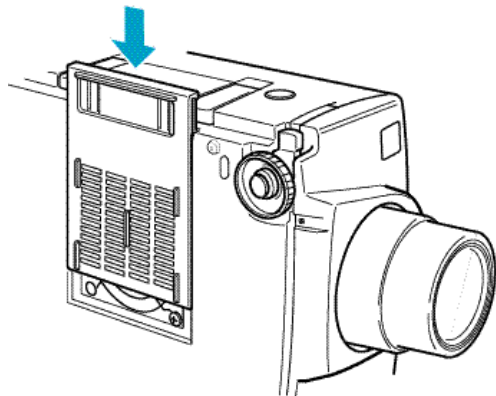

## 6.Product specifications

### 6-1.Projector specifications

#### 6-1-1.Model EMP-7350/EMP-7250/EMP-5350

Product name	Multimedia projector		
Model name	EMP-7350/ EMP-7250/ EMP-5350		
Dimension	300 [W] x 129 [H] x 400 [D] mm (lens foot included)		
Size of panel corner to the lower right corner])	1.3 inches (27 mm [W] x 20 mm [H] x 34 mm [from the upper left		
Type of display	Poly-silicon TFT		
Drive	<EMP-7350/EMP-7250> Full line 12-phase block sequential writing		
	< EMP-5350> Full line 6-phase block sequential writing		
Resolution	<EMP-7350/EMP-7250> 2,359,296 pixels (1024 (horizontal) x 768 (vertical) dots x 3)		
	<EMP-5350> 1,440,000 pixels (800 (horizontal) x 600 (vertical) dots x 3)		
Focus adjustment	Manual		
Zoom adjustment	Manual 1:approx. 1.3 E-Zoom with remote control 1:approx. 4		
(Light source) Lamp	UHE lamp Model ELPLP05, 150W rating		
Maximum audio output	3W x 2 stereo		
Internal speaker	2		
Power supply	120 VAC, 50/60 Hz		
Power consumption	approx. 200 W		
Operation temperature	+5 to +40°C(non-condensing)		
Storage temperature	-10 to +60°C(non-condensing)		
Weight	approx. 6.2 kg		
Connecting terminals	Computer	2 lines	High-density 15-pin micro-D-style (female)
	Computer Output	1 line	High-density 15-pin micro-D-style (female)
	Audio1 (for Computer1)	2 lines	Stereo mini jack
	Audio2 (for Computer2)	2 lines	Stereo mini jack
	Mouse/Com	2 lines	13-pin DIN jack
	Video	1 line	RCA pin jack
	S-Video	1 line	4-pin micro-DIN-style
	Audio input	2 lines	RCA pin jack x 2 (L, R)
	Remote	1 line	Stereo mini jack
	BNC	1 line	5BNC (female)
	Audio output	1 line	Stereo mini jack

## 6-1-2.Model EMP-8000

Product name	Multimedia projector		
Model name	EMP-8000		
Dimension	305 [W] x 157 [H] x 475 [D] mm (lens foot included)		
Size of panel corner to the lower right corner])	1.3 inches (27 mm [W] x 20 mm [H] x 34 mm [from the upper left		
Type of display	Poly-silicon TFT		
Drive	Full line 12-phase block sequential writing		
Resolution	2,359,296 pixels (1024 (horizontal) x 768 (vertical) dots x 3)		
Focus adjustment	Manual		
Zoom adjustment	Manual 1:approx. 1.3 E-Zoom with remote control 1:approx. 4		
(Light source) Lamp	UHE lamp Model ELPLP08, 220W rating		
Maximum audio output	3W x 2 stereo		
Internal speaker	2		
Power supply	120 VAC, 50/60 Hz		
Power consumption	approx. 360 W		
Operation temperature	+5 to +40°C(non-condensing)		
Storage temperature	-10 to +60°C (non-condensing)		
Weight	approx. 8.3 kg		
Connecting terminals			
	Computer	1 line	High-density 15-pin micro-D-style (female)
	Monitor	1 line	High-density 15-pin micro-D-style (female)
	Audio1 (for Computer1)	1 line	Stereo mini jack
	Audio2 (for Computer2)	2 lines	RCA pin jack x 2 (L, R)
	Mouse/Com	2 lines	Multipolar jack
	Video	1 line	RCA pin jack
	S-Video	1 line	4-pin micro-DIN-style
	Audio input	2 lines	RCA pin jack x 2 (L, R)
	Remote	1 line	Stereo mini jack
	BNC	1 line	5BNC (female)
	Audio output	1 line	Stereo mini jack

## 6-2.Lens specifications

### 6-2-1.Long zoom lens (ELPLL02)

Focal length	68.3 to 116.2 mm
Zoom ratio	1:1.7
F number	2.14 to 2.98
Projection size	40 to 300 inches
Weight	approx. 1900 g

### 6-2-2.Wide conversion lens (ELPCW01)

The projection distance when this lens is used is 0.765 times shorter than when the standard lens is used if the screen size is same.

Magnification	1:0.765
Size	100 (diameter) x 90 mm (length)
Weight	approx. 900 g

## 6-3. Using the control panel on the projector

### 6-3-1. Model EMP-7350/EMP-7250/EMP-5350

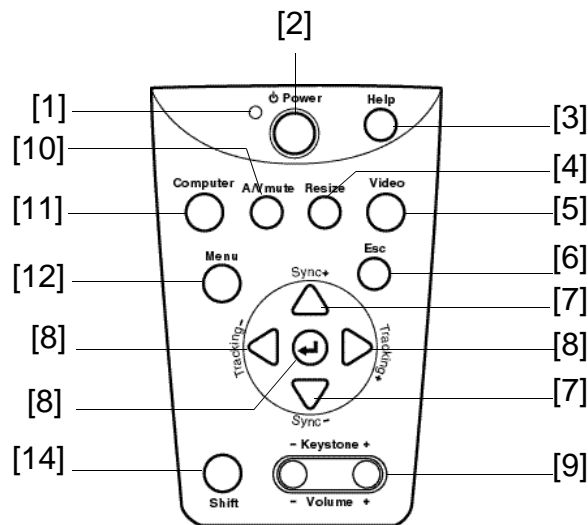

#### [1] Operation indicator

It tells you the projector's operating status.

#### [2] Power button

It is used to start or stop projection.

#### [3] Help button

It is used to describe how to handle a problem by item.

#### [4] Resize button

It switches the display dot mode and resize mode.

#### [5] Video button

It is used to switch to S-Video 1, Composite Video, or Component Video.

#### [6] >Esc button

It is used to terminate the function that is executed currently.

During menu or help operations, it is used to go back to the next higher layer.

#### [7] Sync button

It is used to adjust an overall image that is fuzzy or streaked.

During menu or help operations, it acts as a up or down arrow key.

#### [8] Tracking button

It is used to adjust an image with vertical fuzzy lines.

During menu or help operations, it acts as a right or left arrow key.

#### [9] Keystone (Volume) button

It is used to adjust an image with trapezoidal distortion. It can be used to adjust the volume with this key and Shift button pressed simultaneously.



**[10]A/V Mute button**

It is used to switch to S-Video 1, Composite Video, or Component Video.

**[11]Computer button**

It is used to switch to Computer 1, Computer 2, BNC (RGB), or Component Video.

**[12]Menu button**

It is used to display or hide the menu.

**[13]↵(Enter) button**

It is used to register a menu selection.

During menu or help operations, it is used to go forward to the next lower layer if any. If menu or help operations are not performed, the computer image is optimized.

The input resolution is switched to "Auto" if it is set to "Manual".

**[14]Shift button**

It can be used to adjust the volume with this key and Keystone (Volume) button pressed simultaneously.

## 6-3-2.Model EMP-8000

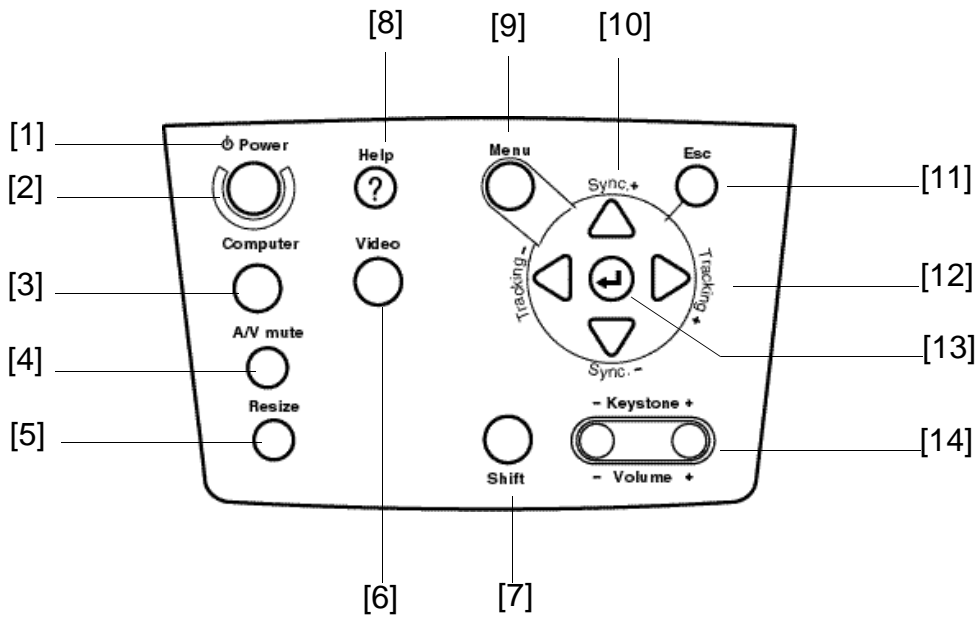

### [1]Operation indicator

It tells you the projector's operating status.

### [2]Power button

It is used to start or stop projection.

### [3]Computer button

It is used to switch to Computer 1, Computer 2, BNC (RGB), or Component Video.

### [4]A/V Mute button

It is used to cut off video and audio temporarily. You can project the user log during this time. The video and audio are restored when pressing this button again, or adjusting the volume.

### [5]Resize button

It switches the display dot mode and resize mode.

### [6]Video button

It is used to switch to S-Video, or Video.

### [7]Shift button

It can be used to adjust the volume with this key and Keystone (Volume) button pressed simultaneously.

### [8]Help button

It is used to describe how to handle a problem by item.

### [9]Menu button

It is used to display or hide the menu.

**[10]Sync button**

It is used to adjust an overall image that is fuzzy or streaked.  
During menu or help operations, it acts as a up or down arrow key.

**[11]Esc button**

It is used to terminate the function that is executed currently.  
During menu or help operations, it is used to go back to the next higher layer.

**[12]Tracking button**

It is used to adjust an image with vertical fuzzy lines.  
During menu or help operations, it acts as a right or left arrow key.

**[13]↵(Enter) button**

It is used to register a menu selection.  
During menu or help operations, it is used to go forward to the next lower layer if any. If menu or help operations are not performed, the computer image is optimized.  
The input resolution is switched to "Auto" if it is set to "Manual".

**[14]Keystone (Volume) button**

It is used to adjust an image with trapezoidal distortion. It can be used to adjust the volume with this key and Shift button pressed simultaneously.

## 6-4. Using the remote control

The remote control can be used commonly among all models.

### 6-4-1. Front

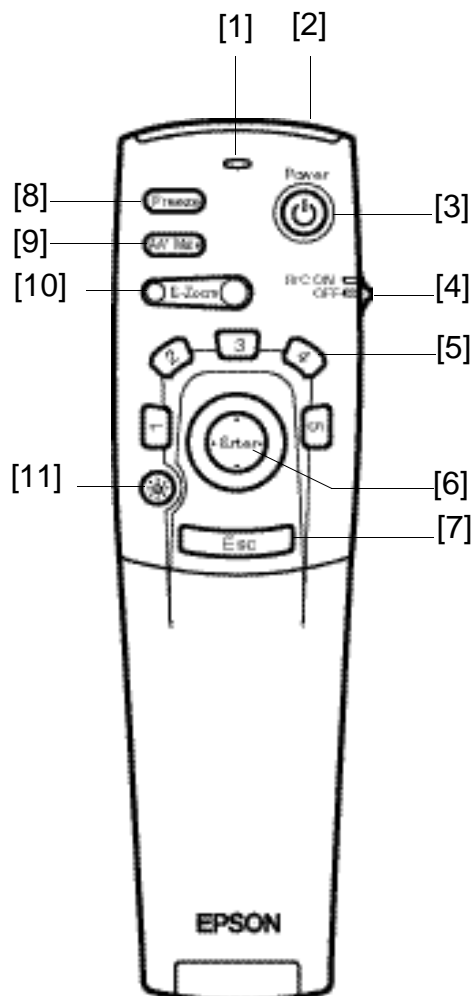

#### [1] Indicator

It comes on while the remote control signal is output.

#### [2] Remote control sender

It outputs the remote control signal.

#### [3] Power button

It is used to start or stop the projector.

#### [4] R/C ON OFF button

It is used to turn on or off the remote control.  
If this button is not set to "ON", you can not operate the remote control.

#### [5] Effects buttons

It is used to perform the special effect function assigned to each button.

#### [6] Enter button

- It is used to register a menu selection.
- It is used to go forward to the next lower layer if any.
- If the computer image is projected, it act as a left mouse click.
- It is used to use the remote as a mouse pointer.
- During menu operations, it is used to navigate the menus for selection of adjustment item.

#### [7] Esc button

It is used to terminate the function that is executed currently.  
During menu or help operations, it is used to go back to the next higher layer.  
If the computer image is projected, it act as a right mouse click.

#### [8] Freeze button

It is used to keep the current or video image on the screen temporarily. The image is unfreezed when pressing this button again.

#### [9] A/V Mute button

It is used to cut off video and audio temporarily. You can project the user log during this time. The video and audio are restored when pressing this button again, or pressing Volume button.

#### [10] E-Zoom button

It is used to perform the E-Zoom function.

#### [11] (Illumination) button

All buttons on the remote control are illuminated for about 10 seconds.

## 6-4-2. Inside of the cover

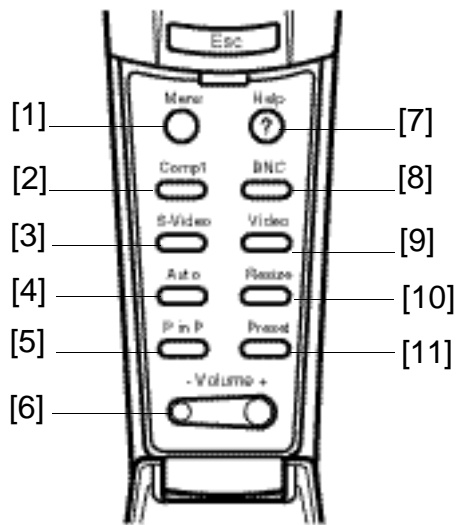

### [1] Menu button

It is used to display or hide the menu.

### [2] Comp1 button

It is used to switch to Computer1.

### [3] S-Video button

It is used to switch to S-Video.

### [4] Auto button

The computer image is optimized.

### [5] Pin P button

It is used to display the video image as a child image on the computer image.

### [6] Volume button

It is used to adjust the volume.

### [7] Help button

It is used to describe how to handle a problem by item.

### [8] Comp2/BNC button

It is used to switch to BNC.

To activate this button, place the BNC switch of the I/O terminal at the back of the projector to the "BNC" side (EMP-7350/EMP7250/EMP-5350).

### [9] Video button

It is used to switch to Video.

### [10] Resize button

If the computer image is projected, it switches the display dot mode and resize mode. If the video image is projected, switch the aspect ratio between 4:3 and 16:9.

### [11] Preset button

It is used to promptly adjust the display by invoking the preset value of the computer input signal.

## 6-5.I/O terminals

### 6-5-1.Model EMP-7350/EMP-7250/EMP-5350

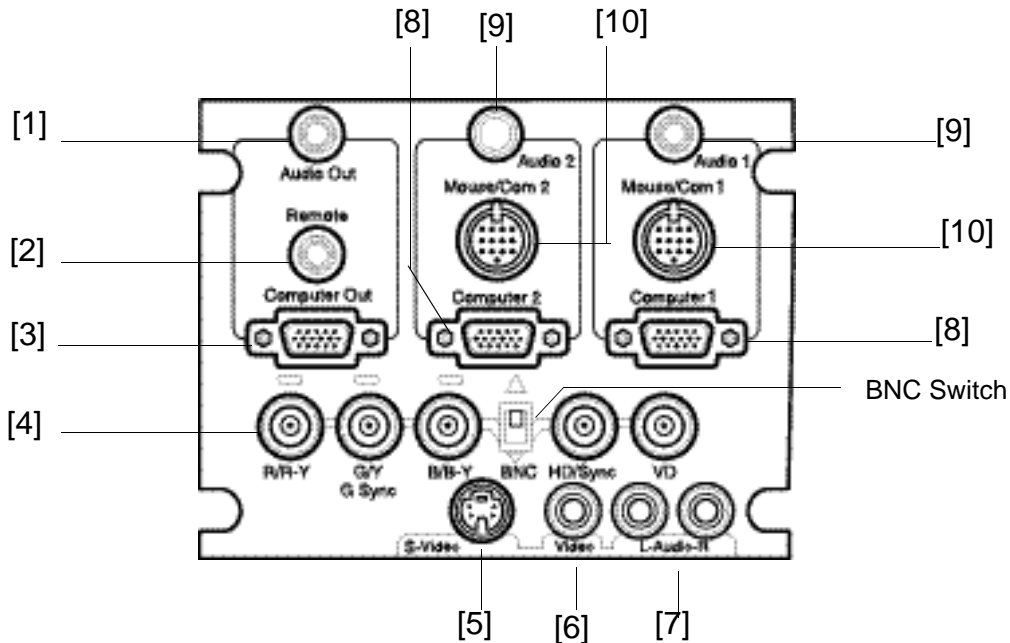

#### [1]Audio Out

It is used to output the audio signal from the projector.

#### [2]Remote

It is used to connect the optional remote control receiver.

#### [3]Computer Out

It is used to output the signal from the computer.

#### [4]BNC

- R/R-Y
- G/Y
- G Sync
- B/B-Y
- HD/Sync
- VD

It is used to input the BNC video signal from the workstation, or the component video signal (color-difference signal) from the video.

To use the image from this terminal, place the BNC switch of the I/O terminal at the back of the projector to the "BNC" side.

#### [5]S-Video

It is used to input the S-Video signal from the A/V equipment.

#### [6]Video

It is used to input the video signal from the A/V equipment.

**[7]L-Audio-R**

It is used to input the audio signal from the A/V equipment.

**[8]Computer1/2**

It is used to input the video signal from the computer.

**[9]GAudio1 /2**

It is used to input the audio signal from the A/V equipment through a stereo mini jack.

**[10]Mouse/Com1/2**

It is used to connect to the computer when using the remote control as a wireless mouse, or the Projector Software supplied with the projector.

## 6-5-2.Model EMP-8000

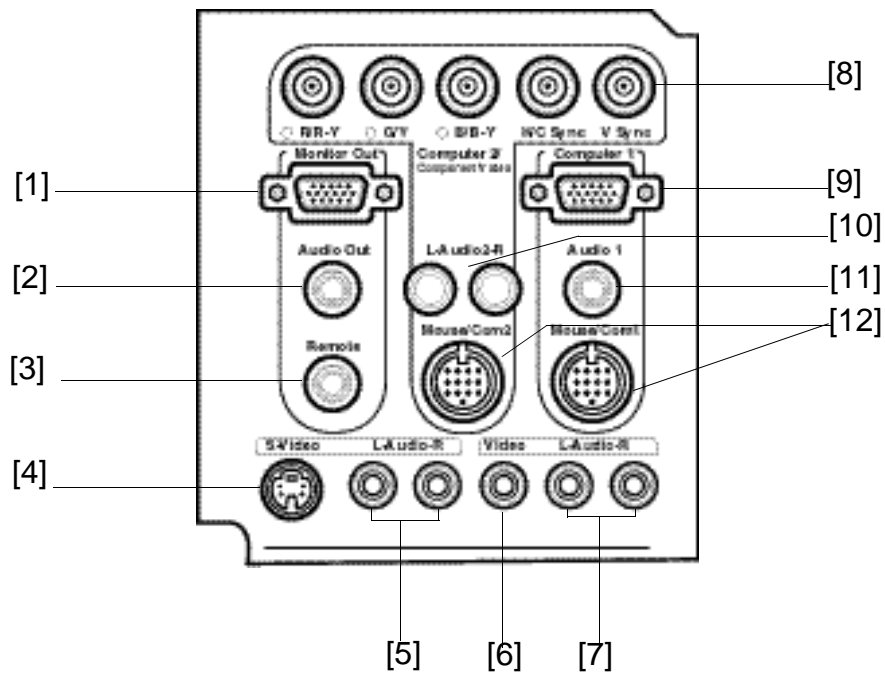

### [1] Monitor Out

It is used to output the video signal.

The signal input from the Computer and BNC terminals is output.

### [2] Audio Out

It is used to output the audio signal from the projector.

### [3] Remote

It is used to connect the optional remote control receiver.

### [4] S-Video

It is used to input the S-Video signal from the A/V equipment.

### [5] L-Audio-R

It is used to input the audio signal from the A/V equipment.

### [6] Video

It is used to input the video signal from the A/V equipment.

### [7] L-Audio-R

It is used to input the audio signal from the A/V equipment through a RCA pin jack.

### [8] BNC

- R/R-Y
- G/Y
- G Sync
- B/B-Y



- HD/Sync
- VD

It is used to input the BNC video signal from the workstation, or the component video signal (color-difference signal) from the video.

To use the image from this terminal, place the BNC switch of the I/O terminal at the back of the projector to the "BNC" side.

#### **[9]Computer1**

It is used to input the video signal from the computer.

#### **[10]L-Audio2-R**

It is used to input the audio signal from the A/V equipment through a RCA pin jack.

#### **[11]Audio1**

It is used to input the audio signal from the A/V equipment through a stereo mini jack.

#### **[12]Mouse/Com1/2**

It is used to connect to the computer when using the remote control as a wireless mouse, or the Projector Software supplied with the projector.

### 6-6. Dimensional diagram

#### 6-6-1. Projector <Model EMP-8000>

- Upeer sede

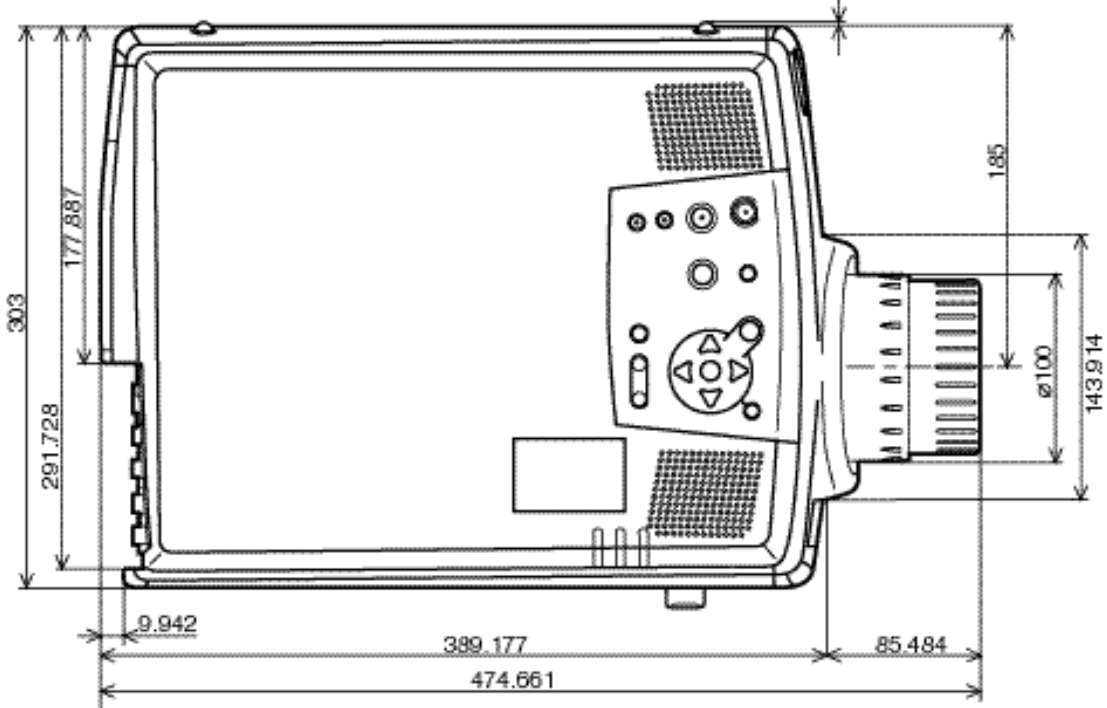

- Left Side

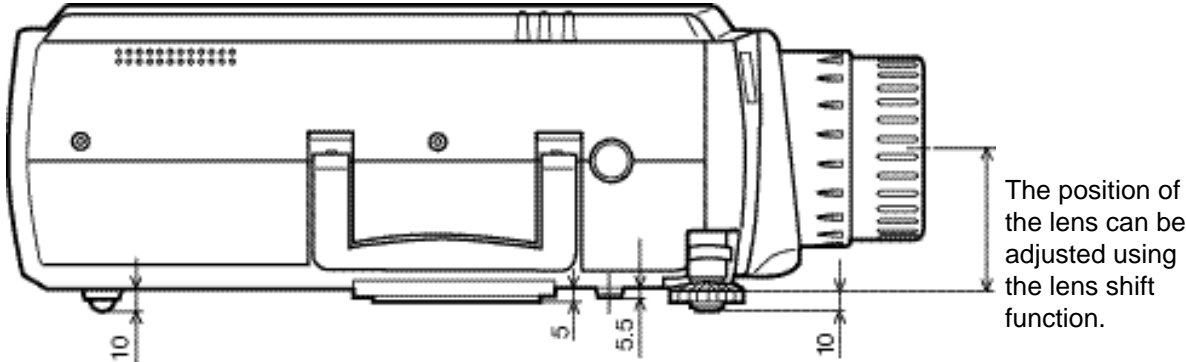

• Right Side

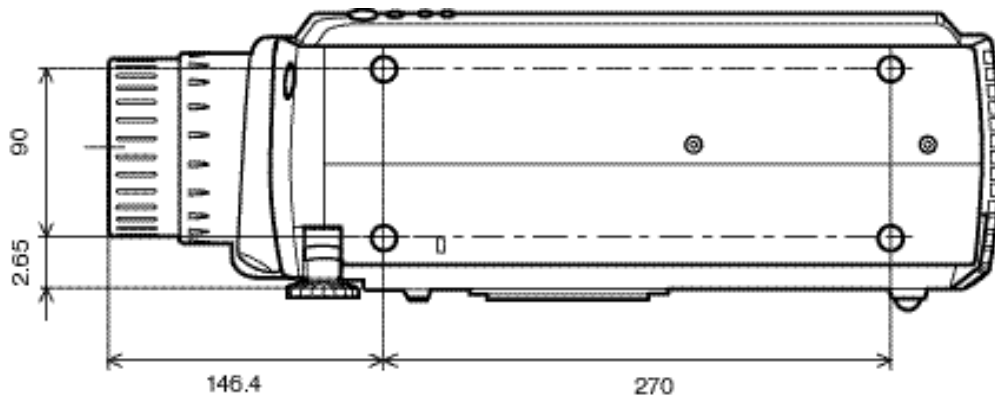

• Back Side

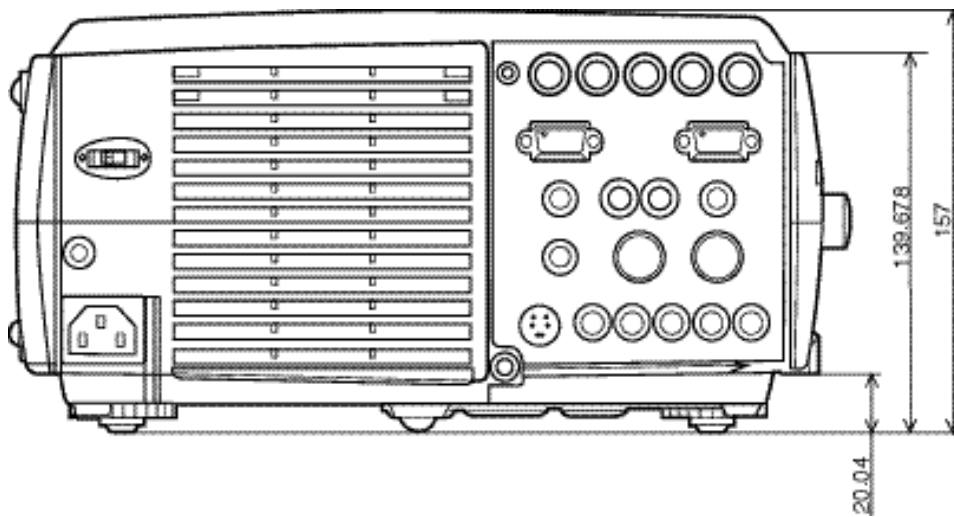

• Front Side

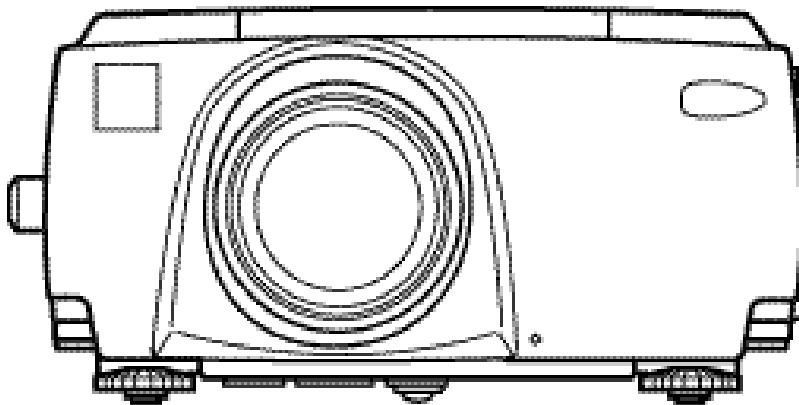

• Botom Side

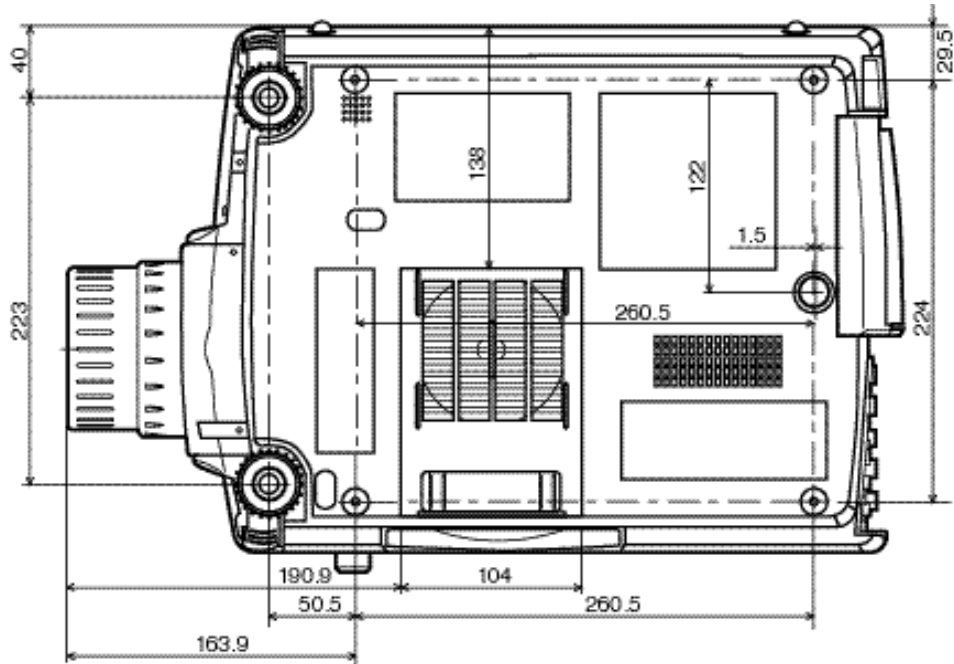

6-6-2.I/O panel

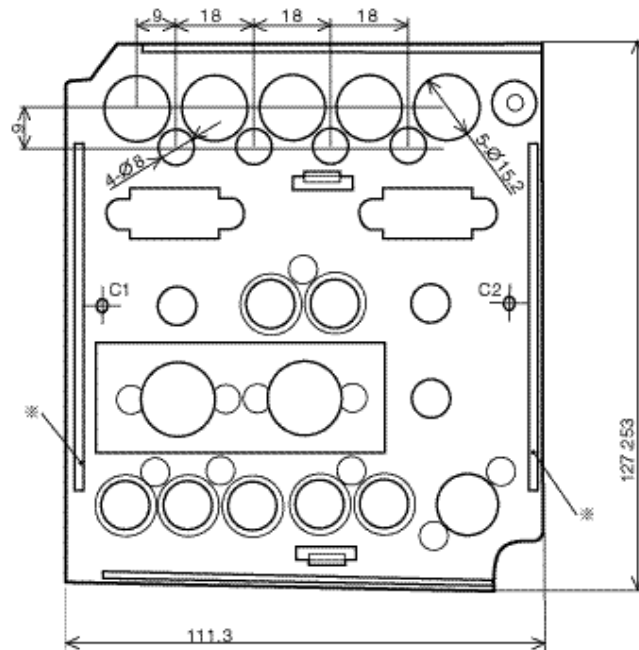

## 6-7.Connector pin assignments

### 6-7-1.Computer1/2 In

15-pin micro-D-style connector

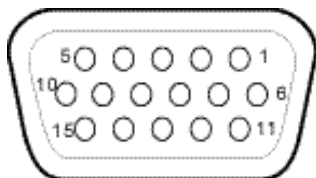

Pin No.	Signal
1	Red video input
2	Green video input
3	Blue video input
4	Monitor bit ID input (Bit 2)2
5	GND
6	Red video GND
7	Green video GND
8	Blue video GND

Pin No	Signal
9	NC
10	Sync GND
11	Monitor bit ID input (Bit 0)
12	SDA
13	Horizontal sync/composite sync input
14	Vertical sync input
15	SCL

### 6-7-2.Audio1 In

3.5 mm stereo mini jack

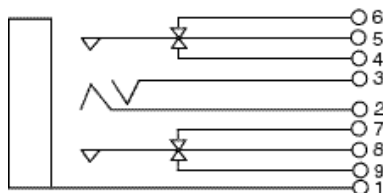

Pin No.	Signal
1	GND
2	Computer audio input L
3	Computer audio input R
4 to 9	NC

### 6-7-3.Audio Out

3.5 mm stereo mini jack

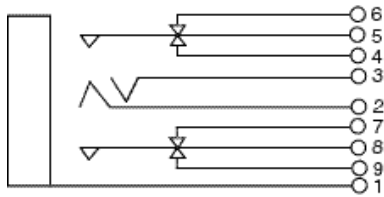

Pin No.	Signal
1, 6 to 9	GND
2	Audio output L
3	Audio output R
4	NC
5	Line out jack plug-in detection

### 6-7-4.Computer Out(Model EMP-800:Monitor Out)

15-pin micro-D-style connector

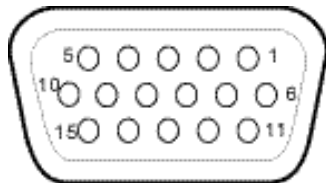

Pin No.	Signal	Pin No.	Signal
1	Red video output	9	Reserved
2	Green video output	10	GND
3	Blue video output	11	Reserved
4	Reserved	12	SDA
5	GND	13	Horizontal sync signal output
6	GND	14	Vertical sync signal output
7	GND	15	Vertical sync signal output
8	GND		

### 6-7-5.S-Video In

4-pin micro-DIN-style connector

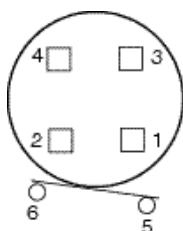

Pin No.	Signal
1, 2, 6	GND
3	Y signal input
4	C signal input
5	Input detection

### 6-7-6.L-Audio-R

RCA type pin jack

### 6-7-7.L-Audio2-R

RCA type pin jack

### 6-7-8.Video

RCA type pin jack

### 6-7-9.Mouse/Com

13-pin multi-mouse jack

The significance of the Mouse/Com pins varies with the mode used.

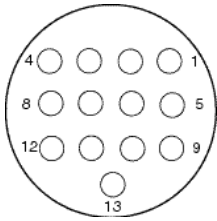

Pin No.	PS/2 mouse	Mac mouse	Serial mouse	PC serial/Mac serial mouse
1	XA	XA	Reserved	Reserved
2	XB	Reserved	Reserved	Reserved
3	Reserved	Reserved	TXD	Reserved
4	Reserved	Reserved	READY	Reserved
5	Reserved	Reserved	GND	Reserved
6	Reserved	Reserved	GND	Reserved
7	Reserved	Reserved	GND	Reserved
8	Reserved	Reserved	Reserved	TXD
9	Reserved	Reserved	Reserved	RXD
10	Reserved	Reserved	Reserved	DTR
11	Reserved	Reserved	Reserved	DSR
12	PCV(+5V)	PCV(+5V)	Reserved	Reserved
13	GND	GND	GND	GND

### 6-7-10.Remote

3.5 mm stereo mini jack

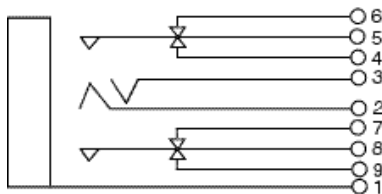

Pin No.	Signal
1, 2, 6	GND
2	Repeater detect signal
3	LED lamp



## 6-8.Main cable

