

Proof Sign-off:

K. Nishi

N.Nomoto

J.Hoadley

PapU

booklet.fm Rev. A

A5 size
4/28/99

BookletENew.fm
Pass 2

R

Hardware & Software Setup

EPSON®

24-Pin Dot Matrix Printer

LQ-2080

All rights reserved. No part of this publication may be reproduced, stored in a retrieval system, or transmitted in any form or by any means, electronic, mechanical, photocopying, recording, or otherwise, without the prior written permission of SEIKO EPSON CORPORATION. The information contained herein is designed only for use with this EPSON printer. EPSON is not responsible for any use of this information as applied to other printers.

Neither SEIKO EPSON CORPORATION nor its affiliates shall be liable to the purchaser of this product or third parties for damages, losses, costs, or expenses incurred by the purchaser or third parties as a result of: accident, misuse, or abuse of this product or unauthorized modifications, repairs, or alterations to this product, or (excluding the U.S.) failure to strictly comply with SEIKO EPSON CORPORATION's operating and maintenance instructions.

SEIKO EPSON CORPORATION shall not be liable for any damages or problems arising from the use of any options or any consumable products other than those designated as Original EPSON Products or EPSON Approved Products by SEIKO EPSON CORPORATION.

EPSON and EPSON ESC/P are registered trademarks and EPSON ESC/P 2 is a trademark of SEIKO EPSON CORPORATION.

Microsoft, Windows, and Windows NT are registered trademarks of Microsoft Corporation.

IBM is a registered trademark of International Business Machines Corporation.

General Notice: Other product names used herein are for identification purposes only and may be trademarks of their respective owners. EPSON disclaims any and all rights in those marks.

Copyright © 1999 by EPSON Deutschland GmbH, Düsseldorf.

Proof Sign-off:
K. Nishi
N.Nomoto
J.Hoadley

PapU
booklet.fm Rev. A

A5 size
4/28/99

BookletENew.fm
Pass 2

R

Declaration of Conformity

According to ISO/IEC Guide 22 and EN 45014

Manufacturer: SEIKO EPSON CORPORATION

Address: 3-5, Owa 3-chome, Suwa-shi,
Nagano-ken 392-8502 Japan

Representative: EPSON EUROPE B.V.

Address: Prof. J. H. Bavincklaan 5 1183
AT Amstelveen
The Netherlands

Declares that the Product:

Product Name: Dot Matrix Printer

Model: P911B

Conforms to the following Directive(s) and Norm(s):

Directive 73/23/EEC:
EN 60950

Directive 89/336/EEC:
EN 55022 Class B
EN 61000-3-2
EN 61000-3-3
EN 50082-1
IEC 801-2
IEC 801-3
IEC 801-4

April 1999

H. Horiuchi

President of EPSON EUROPE B.V.

Proof-Abzeichnung:

K. Nishi

N.Nomoto

J.Hoadley

**PapU
booklet.fm Rev. A**

A5-Format
4/28/99

BookletENew.fm
Durchlauf 2

R

■ **Contents**

Where to Find Information	4
Important Safety Instructions	5
ENERGY STAR Compliance	6
Symbols used in the Manual	6
Setting Up the Printer	7
Unpacking the Printer.	7
Choosing a Place for the Printer.	8
Positioning the continuous paper supply	9
Installing or Replacing the Ribbon Cartridge.	9
Attaching the Paper Guide and Paper Separator	13
Plugging in the Printer	15
Connecting the Printer to Your Computer	15
Installing the Printer Software	16
Loading Single Sheets in the Top Paper Slot	18
Printing	20
Using the Online Manuals	21
Installing the Adobe Acrobat Reader	22
Accessing the Online Manuals from CD-ROM	22
Accessing the Online Manuals from hard disk	23
Customer support	24

■ Where to Find Information

■ Hardware & Software Setup (this manual)

This guide provides you with information and instructions on how to unpack and set up your printer and how to install the printer software. Here you will find instructions on using the online documentation provided on CD-ROM.

■ Online Documentation

The CD-ROM shipped with your printer includes the following on-line documentation in PDF format.

User's Guide

This guide leads you through the printer setup and options installation and tells you how to use the printer. It also offers troubleshooting tips.

■ Online Help

The online help provides detailed information and instructions for the printer software that controls your printer (the online help is installed automatically together with the software).

Proof-Abzeichnung:

K. Nishi

N.Nomoto

J.Hoadley

PapU
booklet.fm Rev. A

A5-Format
4/28/99

BookletENew.fm
Durchlauf 2

R

■ Important Safety Instructions

Read all of these instructions and save them for later reference. Follow all warnings and instructions marked on the printer.

- Do not place the printer on an unstable surface or near a radiator or heat source.
- Place the printer on a flat surface. The printer will not operate properly if it is tilted or at an angle.
- Do not block or cover the openings in the printer's cabinet. Do not insert objects through the slots.
- Use only the type of power source indicated on the printer's label.
- Connect all equipment to properly grounded power outlets. Avoid using outlets on the same circuit as photocopiers or air control systems that regularly switch on and off.
- Do not use a damaged or frayed power cord.
- If you use an extension cord with the printer, make sure the total ampere rating of all devices plugged into the extension cord does not exceed the cord's ampere rating. Also, make sure the total of all devices plugged into the wall outlet does not exceed the wall outlet's ampere rating.
- Unplug the printer before cleaning, and clean it with a damp cloth only.
- Do not spill liquid on the printer.
- Except as specifically explained in this guide, do not attempt to service the printer yourself.
- Unplug the printer and refer servicing to qualified service personnel under the following conditions:
 - If the power cord or plug is damaged; if liquid has entered the printer; if the printer has been dropped or the cabinet damaged; or if the printer does not operate normally or exhibits a distinct change in performance. Adjust only those controls that are covered by the operating instructions.
-  Printer parts marked with this symbol may be hot. Turn off the printer and let it cool for a few minutes before you touch any printer part marked with this symbol.

- If you plan to use the printer in Germany, observe the following:

To provide adequate short-circuit protection and over-current protection for this printer, the building installation must be protected by a 16 Amp circuit breaker.

Note for German-speaking users:

Bei Anschluß des Druckers an die Stromversorgung muß sichergestellt werden, daß die Gebäudeinstallation mit einem 16 A-Überstromschalter abgesichert ist.

■ ENERGY STAR Compliance

As an ENERGY STAR Partner, EPSON has determined that this product meets the ENERGY STAR guidelines for energy efficiency.

The International ENERGY STAR Office Equipment Program is a voluntary partnership with the computer and office equipment industry to promote the introduction of energy-efficient personal computers, monitors, printers, fax machines, copiers, and scanners, in an effort to reduce air pollution caused by power generation.

■ Symbols used in the Manual**Warnings**

must be followed carefully to avoid bodily injury.

**Cautions**

must be observed to avoid damage to your equipment.

Notes

contain important information and useful tips on the operation of your printer.

Proof-Abzeichnung:

K. Nishi

N.Nomoto

J.Hoadley



PapU booklet.fm Rev. A

A5-Format
4/28/99

BookletENew.fm
Durchlauf 2

R

■ Setting Up the Printer

■ Unpacking the Printer

Besides this guide, your printer box should include EPSON printer software disk, a Notice Sheet, and the following items:

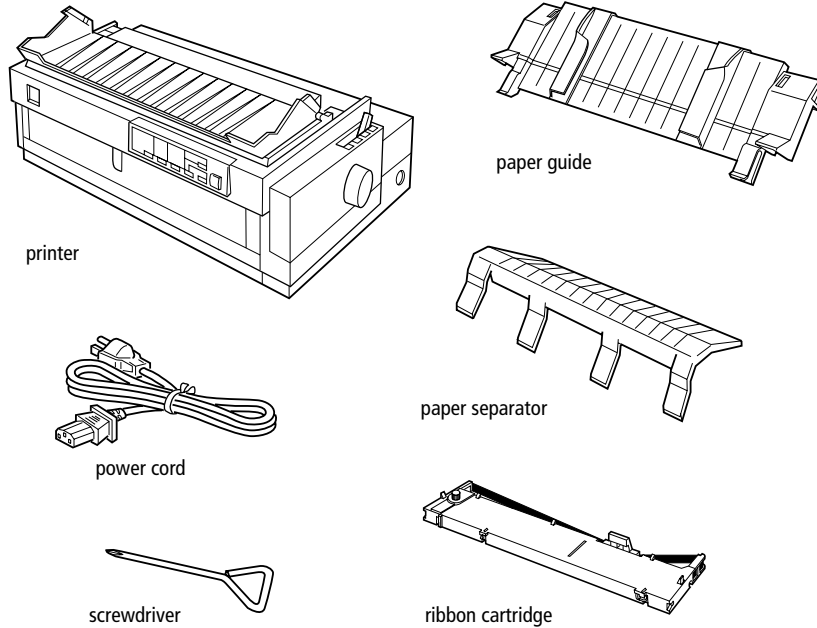

Note:

Depending on your printer model, the power cord may be permanently attached to the printer. Also, the shape of the power cord plug varies depending on the country in which you bought your printer; be sure the plug you have is the right one for your location.



Caution:

There are several models of the printer designed for different voltages, and it is not possible to adjust the printer for use with another voltage. If the label on the back of the printer does not show the correct voltage for your country, contact your dealer.

You must remove all protective materials packed around and inside your printer before you set it up and turn on the power. Follow the directions on the Notice Sheet (packed with the printer) to remove these materials. A screwdriver has been provided for removing the transportation screw.

Save all packing and protective materials, including the transportation screw and the protective locking clips on the paper tension unit, in case you need to ship the printer in the future. It should always be transported in its original packaging or equivalent materials.

■ Choosing a Place for the Printer

Follow the guidelines below when selecting a location for your printer.

- Place the printer on a flat, stable surface. The printer will not operate properly if it is tilted or at an angle.
- Place the printer where you can easily connect it to a network interface cable, if necessary.
- Leave adequate room around the printer for easy operation and maintenance.
- Avoid using or storing the printer in places subject to rapid changes in temperature and humidity. Also keep it away from direct sunlight, strong light, heat sources, or excessive moisture or dust.
- Avoid places subject to shocks and vibrations.
- Place the printer near a wall outlet where you can easily unplug the power cord.
- Avoid electrical outlets controlled by wall switches or automatic timers. An interruption in power can erase information in the memory of your printer or computer.
Also avoid outlets on the same circuit as large motors or other appliances that can cause voltage fluctuations.
- Keep the entire computer system away from potential sources of electromagnetic interference, such as loudspeakers or the base units of cordless telephones.
- Use a grounded power outlet; do not use an adapter plug.
- Make sure the paper path is clear and unobstructed before you print on continuous paper.
- If you plan to use a printer stand, follow these guidelines:
 - Use a stand that supports at least 26 kg (57.8 lb).
 - Never use a stand that tilts the printer. The printer should always be kept level.
 - Position your printer's power cord and interface cable so they do not interfere with paper feeding. If possible, secure the cables to a leg of the printer stand.

Proof-Abzeichnung:

K. Nishi

N.Nomoto

J.Hoadley



PapU booklet.fm Rev. A

A5-Format
4/28/99

BookletENew.fm
Durchlauf 2

R

■ Positioning the continuous paper supply

Before using continuous paper, make sure you line up your paper supply with the tractor feeder so the paper feeds smoothly into the printer, as shown below.

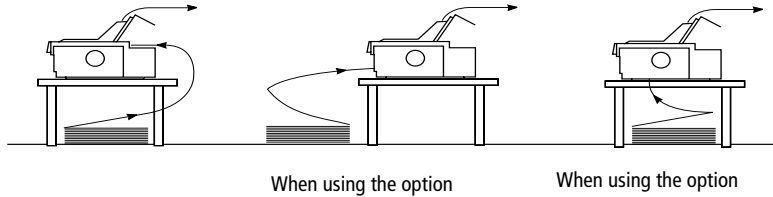

■ Installing or Replacing the Ribbon Cartridge

EPSON recommends using genuine EPSON ribbon cartridges (S015086). Products not manufactured by EPSON may cause damage to your printer not covered by EPSON's warranties.

1. Make sure the printer is turned off. The printer is off when the surface of the **Operate** button is even with the button protectors as shown.

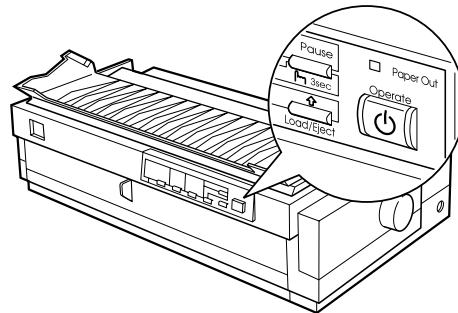

Caution:

Moving the print head while the printer is on may damage the printer.

2. If the printer is connected to an electrical outlet, unplug it from the outlet.

3. Lift the printer cover by its back edge and then pull it straight up and off.

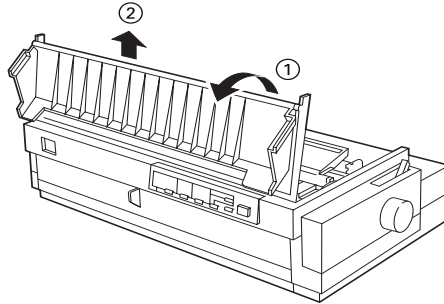

4. Slide the print head to the ribbon installation position (the indented portion of the paper tension unit) by hand.

Note:

When the pull tractor is installed, you can replace the ribbon cartridge when the print head is not in the ribbon installation position.

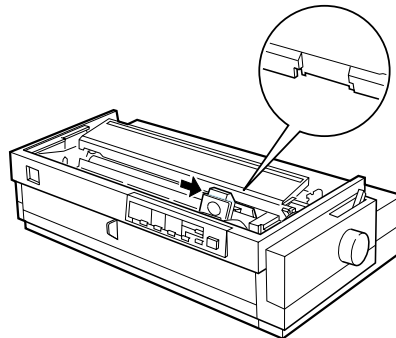



5. Remove the new ribbon cartridge from the package. Remove the separator from the middle of the ribbon cartridge and discard the separator. Then turn the ribbon-tightening knob in the direction of the arrow to remove any slack in the ribbon.

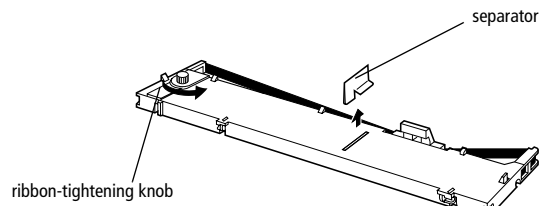

6. Hold the cartridge with the ribbon-tightening knob up. Fit the two front notches of the ribbon cartridge over the small pegs on each side of the printer as shown below. Then lay the cartridge flat.

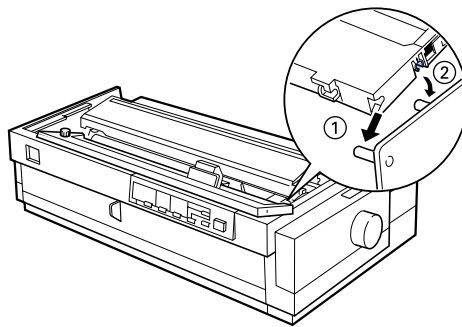

7. Make sure that the two rear notches of the cartridge fit over the small pegs on each side of the printer. Then gently press down the cartridge until both ends click into place.

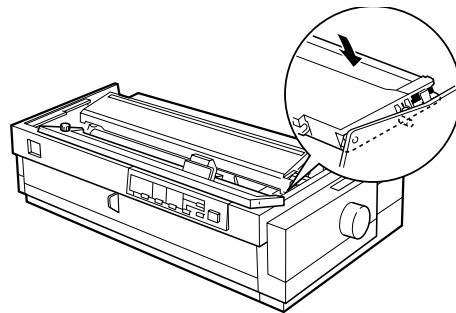

8. Lift the cartridge's ribbon guide (①) and insert it firmly over the metal pins behind the print head (②). Make sure the ribbon is not twisted or creased and that it is in place behind the print head. Then press down the guide until it clicks into place.

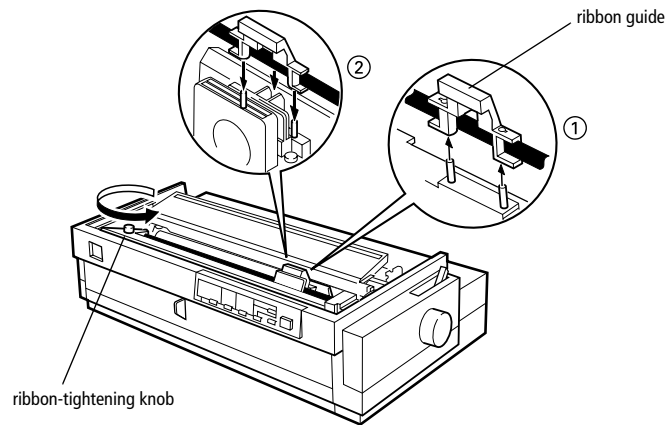

9. Turn the ribbon-tightening knob in the direction of the arrow to remove any slack in the ribbon, as shown above. Then slide the print head from side to side to make sure it moves smoothly.

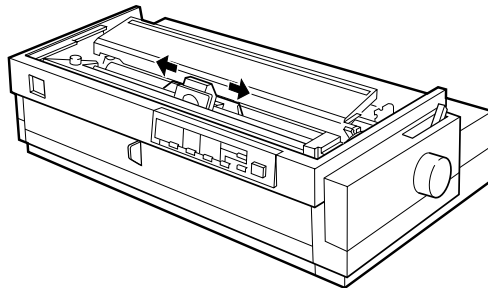

Proof-Abzeichnung:

K. Nishi
N.Nomoto
J.Hoadley



PapU booklet.fm Rev. A

A5-Format
4/28/99

BookletENew.fm
Durchlauf 2

R

10. Replace the printer cover by first inserting the front tabs into the slots on the printer and then lowering the cover until it clicks into place.

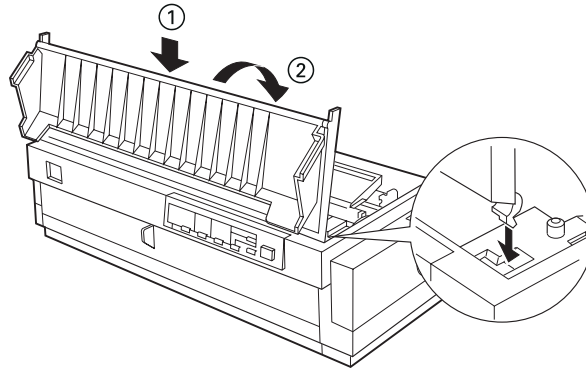

■ Attaching the Paper Guide and Paper Separator

1. Turn over the paper guide and insert the paper separator's tabs into the slots on the paper guide.

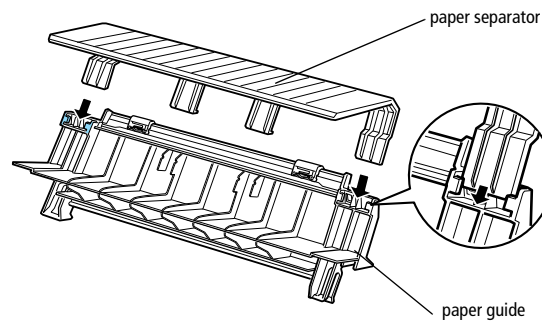



2. Make sure the paper guide cover is open as shown below. Attach the paper guide by sliding the slots on the bottom of the paper guide over the pegs behind the paper tension unit.

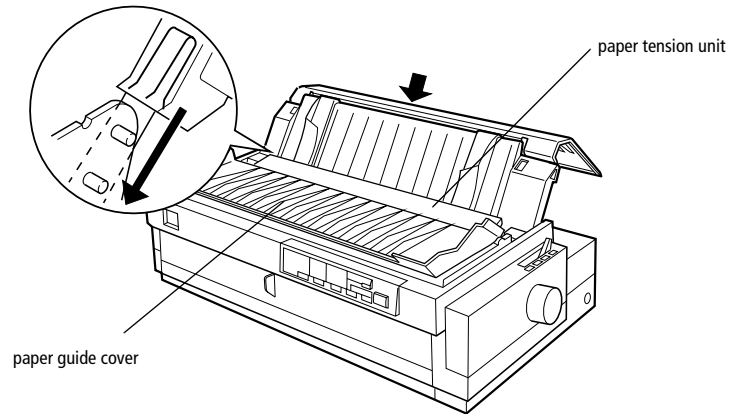

3. Close the paper guide cover.

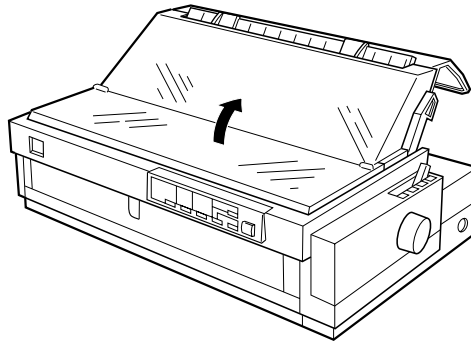



■ Plugging in the Printer

1. Make sure the printer is turned off. The printer is off when the surface of the **Operate** button is even with the button protectors as shown below.

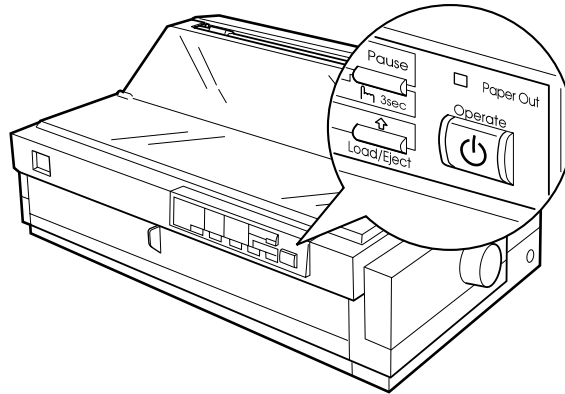

2. Check the label on the back of the printer to make sure its voltage matches that of your electrical outlet. Also make sure the plug on your printer's power cord matches your electrical outlet.



Caution:

It is not possible to change the printer's voltage. If the rated voltage and your outlet voltage do not match, contact your dealer for assistance. Do not plug in the power cord.

3. If the power cord is not attached to the printer, plug the appropriate end into the AC inlet on the back of the printer.
4. Plug the power cord into a properly grounded electrical outlet.

■ Connecting the Printer to Your Computer

To connect your computer to your printer's built-in parallel interface, you need a shielded, twisted-pair, parallel cable with a D-SUB, 25-pin, male connector for your computer and a 36-pin Centronics[®]-compatible connector for the printer.

1. Make sure both the printer and computer are turned off. The printer is off when the surface of the **Operate** button is even with the button protectors.

2. Plug the cable connector securely into the printer's interface connector, and squeeze the wire clips together until they lock in place on both sides of the connector.

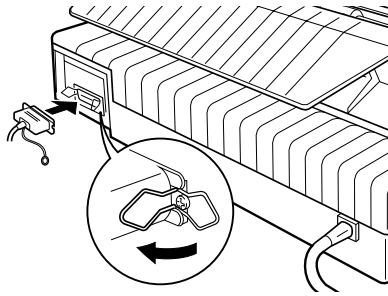

3. If your cable has a ground wire, connect it to the printer's ground connector as shown below.

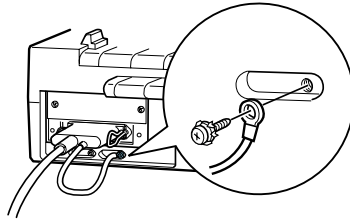

4. Plug the other end of the cable into the computer. (If the cable has a ground wire at the computer end, attach it to the ground connector at the back of the computer.)

After you connect the printer to your computer, install the printer software as described in the next section.

■ Installing the Printer Software

■ Installing the software for Windows 95/98 or NT 4.0

Note:

Installing the printer software for Windows NT[®] 4.0 may require network administration privileges. Ask your network administrator for more information.

1. Make sure that the printer and computer are switched off.
2. Switch the PC on. Windows starts automatically. Then switch the printer on.

3. Insert the CD-ROM containing the printer software into the CD-ROM drive. The AutoPlay function of the CD-ROM drive automatically starts the installation program on the CD-ROM.

If the installation program does not start automatically, click on Start and then on Run. In the Run dialog box, enter the drive letter of your CD-ROM drive in the command line (e.g. E:\), followed by the command START.EXE (e.g. E:\START.EXE) and click on the OK button.

Note:

If your CD-ROM drive has a drive letter other than "E", substitute the appropriate letter.

The installation program starts. The subsequent procedure is menu-driven, i.e., you can select the relevant options from a list simply by clicking with the mouse. The remainder of the installation is automatic and you do not need to enter any more information.

4. Select the desired options and follow the on-screen instructions.
5. After the printer software has been successfully installed, click on the button identified by a door icon to exit the installation program.

■ **Installing the software for Windows 3.1 or NT 3.5x**

Note:

Installing the printer software for Windows NT 3.5x may require network administration privileges. Ask your network administrator for more information.

1. Make sure Windows 3.1 is running and the Program Manager window is open.
2. Insert the EPSON printer software CD shipped with your printer in the CD-ROM drive.

Note:

If your system does not have a CD-ROM drive, you can make a floppy disk version from which to install the printer software.

3. From the File menu, choose Run. You see the Run dialog box. In the Command Line box, type E:\START and click OK.

Note:

If your CD-ROM drive has a drive letter other than "E", substitute the appropriate letter.

The installation program starts. The subsequent procedure is menu-driven, i.e., you can select the relevant options from a list simply by clicking with the mouse. The remainder of the installation is automatic and you do not need to enter any more information.

4. Select the desired options and follow the on-screen instructions.
5. After the printer software has been successfully installed, click on the button identified by a door icon to exit the installation program.

The installation program automatically selects this printer as the default printer for Windows applications.

■ Loading Single Sheets in the Top Paper Slot

To load paper in the top slot, follow these steps:

1. Make sure the paper guide is installed properly.
2. Open the paper guide cover. Slide the left edge guide until it locks in place next to the arrow on the paper guide. Next adjust the right edge guide to match the width of your paper.

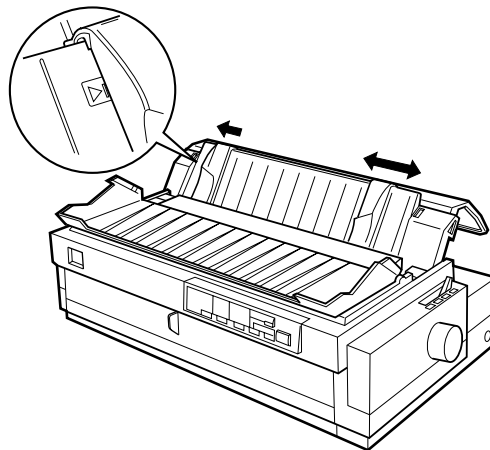

Proof-Abzeichnung:

K. Nishi

N.Nomoto

J.Hoadley



PapU booklet.fm Rev. A

A5-Format
4/28/99

BookletENew.fm
Durchlauf 2

R

3. Set the paper release lever to the single-sheet position. Also set the paper thickness lever (located under the printer cover) to the proper position for your paper's thickness.

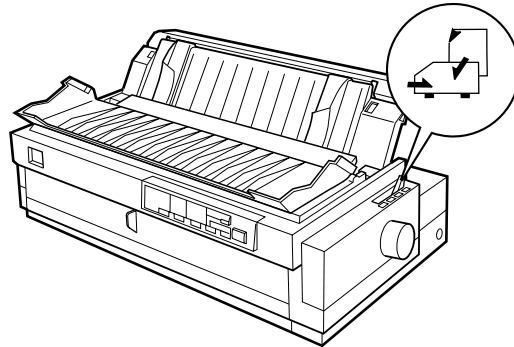

4. Close the paper guide cover.

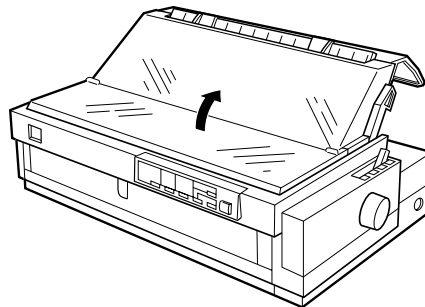

5. Press the **Operate** button to turn on the printer, if necessary.

6. Insert a sheet of paper printable side down between the edge guides until it meets resistance. The printer feeds the paper automatically and is ready to print.

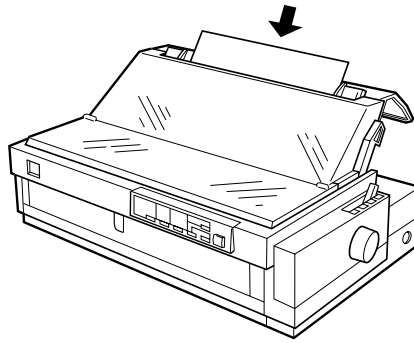
**Note:**

Always close the printer cover before printing.

7. Check the printer driver settings and change them if necessary. Then send a print job to the printer as described in the following chapter.

When the printer receives data, it prints the page and ejects it back onto the paper guide. To continue printing your document, remove the printed page and insert a new sheet of paper. If you need to eject a sheet, press the **Load/Eject** button.

**Caution:**

Never use the knob to adjust the top-of-form position or eject a sheet when the printer is on; this may damage the printer or cause it to lose the top-of-form position.

■ Printing

■ Printing under Windows 95/98 and NT 4.0

1. Select **Print Setup** or **Print** from the **File** menu of your application software. The **Print** or **Print Setup** dialog box appears.
2. Make sure that your printer is selected and then click **Printer, Setup, Properties,** or **Options.** (You may need to click a combination of these buttons.) The **Properties** or **Document Properties** window appears, and you see the **Paper** and **Graphics** menus (Windows 95/98) or the **Page Setup** and **Advanced** menus (Windows NT 4.0). These menus contain the printer driver settings.
3. To view a menu, click the corresponding tab at the top of the window.

4. When you finish making your printer driver settings, click **OK** to apply the settings, or click **Restore Defaults** (Windows 95/98) or **Cancel** (Windows NT) to return the settings to their previous values.
5. Click **Ok** in the **Print** or **Print Setup** dialog box to issue the print job.

■ Printing under Windows 3.1 and NT 3.5x

1. Select **Print Setup** or **Print** from the **File** menu of your application software. The **Print** or **Print Setup** dialog box appears.
2. Make sure that your printer is selected and then click **Printer**, **Setup**, or **Options**. (You may need to click a combination of these buttons.) The **Options** dialog box (Windows 3.1) or the **Document Properties** dialog box (Windows NT 3.5x) appears.
3. When you finish making your printer driver settings, click **OK** to apply the settings, or click **Cancel** to cancel your changes.
4. Click **Ok** in the **Print** or **Print Setup** dialog box to issue the print job.

■ Using the Online Manuals

The CD-ROM shipped with your printer includes online manuals in PDF format (PDF = Portable Document Format). PDF files can be used on various platforms (e.g. Windows, Macintosh, Unix etc.) and are electronic manuals with the same layout, illustrations, tables etc. to be found in a printed manual. You can display the online manuals on your computer screen and print them on any connected printer, if required.

The following manual is available:

■ User's Guide

This guide leads you through the printer setup and options installation and tells you how to use the printer. It also offers troubleshooting tips and customer support information.

To access the manuals you need to install the Adobe Acrobat Reader software, which is also provided on the CD-ROM.

Note:

The Adobe Acrobat Reader program is an easy-to-use application program for displaying and printing online manuals. It offers a wide range of features which allow you to use the online manuals without difficulty to find any desired information. You can read the information online on your computer screen or print it on your printer for later reference. If you need complete information on the Adobe Acrobat Reader, refer to its online help.

If the Acrobat Reader is already installed on your system, you can skip this section and continue with the next section.

Note:

If you are not sure whether the Acrobat Reader is installed on your system, please contact your system administrator or double-click on the menu item for reading the online manual in the setup program. If the Adobe Acrobat Reader is not installed on your system, the manual will not open and an error message will be displayed.

■ Installing the Adobe Acrobat Reader

1. Make sure Windows is running.
2. Insert the CD-ROM that comes with your printer into your computer's CD-ROM drive. The setup program on the CD-ROM will be started automatically and displays the start screen.

If the setup program is not started automatically, click the **Start** button, then click **Run** and enter the command **E:\Start.exe** to start the setup program.

Note:

E:\ represents the letter of your CD-ROM drive and may be different on your computer system.

3. Select the desired language.
4. Select the menu item **Online manuals**.
5. Select the menu item **Install Acrobat Reader** and follow the on-screen instructions.

After the Acrobat Reader has been installed on your system, you can access the online manuals.

The setup program on the CD-ROM offers two possibilities to access the online manuals:

■ Accessing the Online Manuals from CD-ROM

Follow these steps to access the online manuals from CD-ROM:

1. Make sure Windows is running.
2. Insert the CD-ROM that comes with your printer into your computer's CD-ROM drive. The setup program on the CD-ROM will be started automatically and displays the start screen.

If the setup program is not started automatically, click the **Start** button, then click **Run** and enter the command **E:\Start.exe** to start the setup program.

Note:

E: represents the letter of your CD-ROM drive and may be different on your computer system.

3. Select the desired language.
4. Select the menu item **Online manuals**.

The setup program displays a list of available online manuals.

5. Select the desired online manual.
6. Select **Display Read Manual**. The Acrobat Reader will be started automatically and the online manual opened.

■ Accessing the Online Manuals from hard disk

Note:

Before you can access the online manuals from your hard disk, you have to install them on the hard disk.

1. Make sure Windows is running.
2. Insert the CD-ROM that comes with your printer into your computer's CD-ROM drive. The setup program on the CD-ROM will be started automatically and displays the start screen.

If the setup program is not started automatically, click the **Start** button, then click **Run** and enter the command **E:\Start.exe** to start the setup program.

Note:

E: represents the letter of your CD-ROM drive and may be different on your computer system.

3. Select the desired language.
4. Select the menu item **Online manuals**.
5. Select the desired online manual.
6. Select the menu item **Install Online manual on the PC**. The setup program copies all the necessary files to your system's hard disk.

Note:

If you wish you can later delete the manual from the hard disk. To do this, click on the **Software** icon in the **Control Panel**, highlight **EPSON Printer Manuals** and click on **Add/Delete**.

To open and access an online manual, follow the steps below:

1. Click the **Start** button, point to **Programs**, then point to **EPSON Online manuals**.
2. Click on the name of the desired online manual.

The Acrobat Reader will be started automatically and the online manual opened.

■ Customer support

EPSON's Service and Support hotline is available should you require urgent help. You will find the telephone number and further important information for your country in the Service and Support brochure provided with your printer.