

4-bit Single Chip Microcomputer



- 4-bit Core CPU (2–6 clock / inst.)
- Dot-matrix Type LCD Driver
- Low Voltage Operation (1.8V Min.)
- Large Capacity RAM

■ DESCRIPTION

The E0C63404 is a CMOS 4-bit microcomputer composed of a CMOS 4-bit core CPU, ROM, RAM, dot-matrix type LCD driver and timer. E0C63404 features high speed operation and low current consumption, this makes it suitable for applications working with batteries. It is also suitable for caller ID and portable data bank systems because it has a large capacity of RAM built-in.

■ FEATURES

- CMOS LSI 4-bit parallel processing E0C63000 core CPU
- Main clock 32.768kHz (Typ.) Crystal oscillation or 60kHz (Typ.) CR oscillation
- Sub clock 1MHz (Typ.) CR or Ceramic oscillation
- Instruction set Basic instruction : 46 types (411 instructions with all)
Addressing mode : 8 types
- Instruction execution time During operation at 32.768kHz : 61μsec, 122μsec, 183μsec
During operation at 60kHz : 33μsec, 67μsec, 100μsec
During operation at 1MHz : 2μsec, 4μsec, 6μsec
- ROM capacity Code ROM : 4,096 words × 13 bits
Data ROM : 2,048 words × 4 bits
- RAM capacity Data memory : 2,688 words × 4 bits
Display memory : 200 words × 4 bits
- Input port 8 bits
- Output port 12 bits
- I/O port 12 bits
- LCD driver 40 segments × 8 / 16 / 17 commons
- Clock timer 1 ch.
- Stopwatch timer 1 ch.
- Programmable timer 8 bits × 2 ch.
- Watchdog timer Built-in
- Serial interface 8-bit clock synchronous system
- Sound generator With envelope and 1-shot output functions
- Supply voltage detection (SVD) circuit 16 values, programmable (1.85 to 3.30V)
- Interrupts External : Input port interrupt : 2 lines
Internal : Clock timer interrupt : 4 lines
: Stopwatch timer interrupt : 2 lines
: Programmable timer interrupt : 2 lines
: Serial interface interrupt : 1 line
- Package QFP8-128pin (plastic), QFP15-128pin (plastic), Die form
- Supply voltage 1.8 to 6.4V (Min. 2.2V when OSC3 and CR oscillation circuit are used)
- Current consumption HALT mode (32.768kHz, LCD off) : 0.8μA
OPERATING mode (32.768kHz, LCD on) : 10.0μA

■ BLOCK DIAGRAM

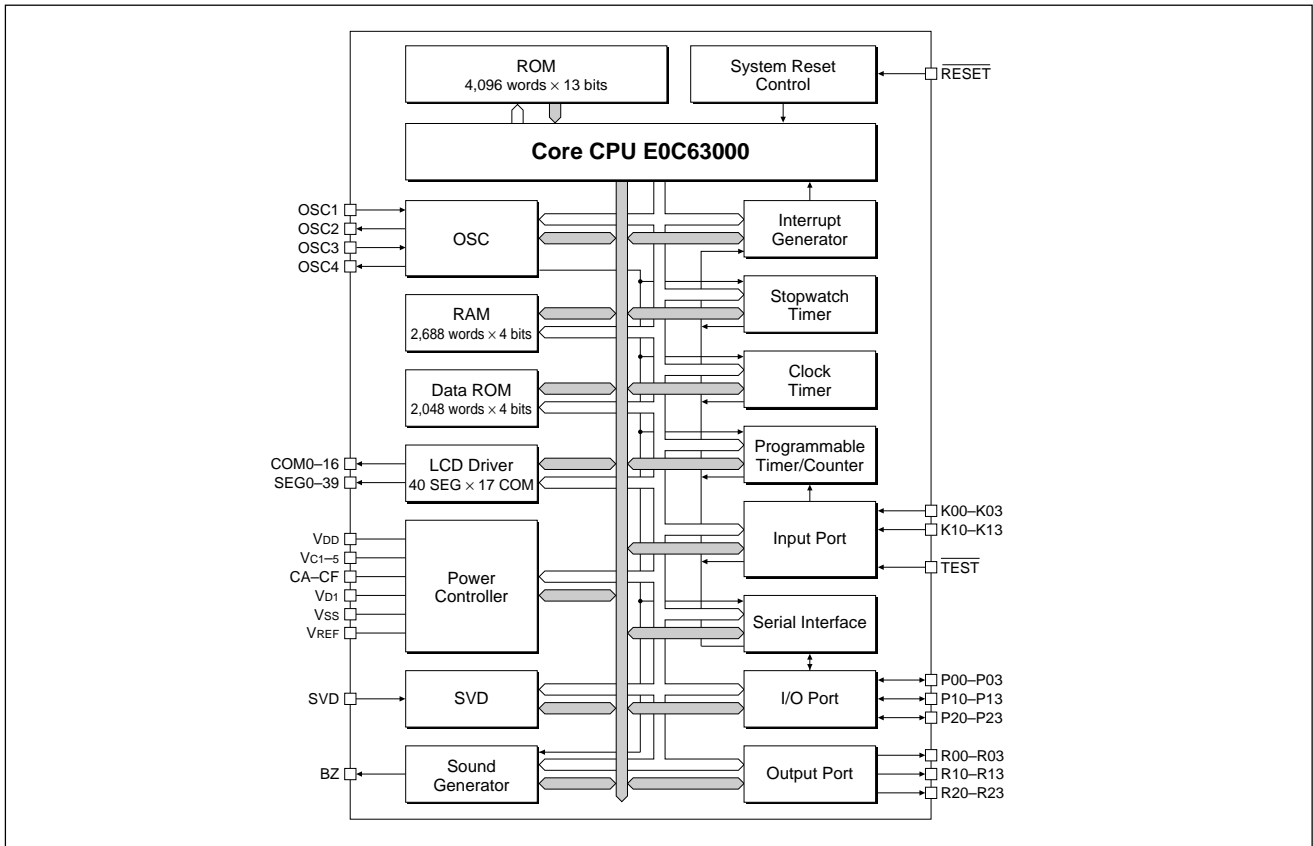

■ PIN CONFIGURATION

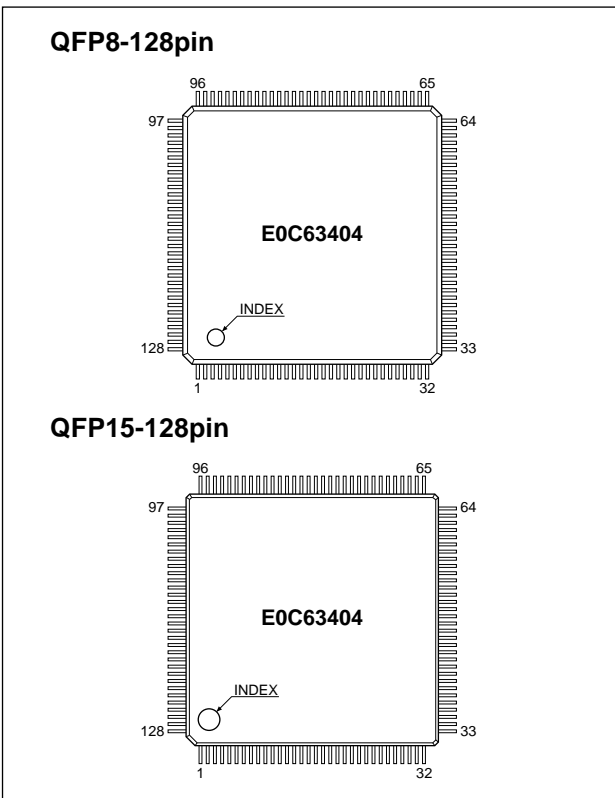

No.	Name	No.	Name	No.	Name	No.	Name
1	N.C.	33	R23	65	N.C.	97	N.C.
2	SEG3	34	R22	66	SVD	98	N.C.
3	SEG2	35	R21	67	N.C.	99	SEG32
4	SEG1	36	R20	68	N.C.	100	SEG31
5	SEG0	37	R13	69	Vc1	101	SEG30
6	COM7	38	R12	70	Vc2	102	SEG29
7	COM6	39	R11	71	Vc3	103	SEG28
8	COM5	40	R10	72	Vc4	104	SEG27
9	COM4	41	R03	73	Vc5	105	SEG26
10	COM3	42	R02	74	CF	106	SEG25
11	COM2	43	R01	75	CE	107	SEG24
12	COM1	44	R00	76	CD	108	SEG23
13	COM0	45	P23	77	CC	109	SEG22
14	N.C.	46	P22	78	CB	110	SEG21
15	N.C.	47	P21	79	CA	111	SEG20
16	N.C.	48	P20	80	COM8	112	SEG19
17	BZ	49	P13	81	COM9	113	SEG18
18	VSS	50	P12	82	COM10	114	SEG17
19	OSC1	51	P11	83	COM11	115	SEG16
20	OSC2	52	P10	84	COM12	116	SEG15
21	Vd1	53	P03	85	COM13	117	SEG14
22	OSC3	54	P02	86	COM14	118	SEG13
23	OSC4	55	P01	87	COM15	119	SEG12
24	VDD	56	P00	88	COM16	120	SEG11
25	N.C.	57	K13	89	SEG39	121	SEG10
26	N.C.	58	K12	90	SEG38	122	SEG9
27	N.C.	59	K11	91	SEG37	123	SEG8
28	RESET	60	K10	92	SEG36	124	SEG7
29	TEST	61	K03	93	SEG35	125	SEG6
30	VREF	62	K02	94	SEG34	126	SEG5
31	N.C.	63	K01	95	SEG33	127	SEG4
32	N.C.	64	K00	96	N.C.	128	N.C.

N.C. : No Connection

■ PIN DESCRIPTION

Pin name	Pin No.	In/Out	Function
VDD	24	-	Power (+) supply pin
VSS	18	-	Power (-) supply pin
VD1	21	-	Oscillation/internal logic system regulated voltage output pin
VC1-VC5	69-73	-	LCD system power supply pin 1/4 bias generated internally, 1/5 bias supplied externally (selected by mask option)
VREF	30	O	LCD system power supply testing pin
CA-CF	79-74	-	LCD system boosting/reducing capacitor connecting pin
OSC1	19	I	Crystal or CR oscillation input pin (selected by mask option)
OSC2	20	O	Crystal or CR oscillation output pin (selected by mask option)
OSC3	22	I	Ceramic or CR oscillation input pin (selected by mask option)
OSC4	23	O	Ceramic or CR oscillation output pin (selected by mask option)
K00-K03	64-61	I	Input port
K10-K13	60-57	I	Input port
P00-P03	56-53	I/O	I/O port
P10-P13	52-49	I/O	I/O port (switching to serial I/F input/output is possible by software)
P20	48	I/O	I/O port
P21	47	I/O	I/O port
P22	46	I/O	I/O port (switching to CL signal output is possible by software)
P23	45	I/O	I/O port (switching to FR signal output is possible by software)
R00	44	O	Output port
R01	43	O	Output port
R02	42	O	Output port (switching to TOUT signal output is possible by software)
R03	41	O	Output port (switching to FOUT signal output is possible by software)
R10-R13	40-37	O	Output port
R20-R23	36-33	O	Output port
COM0-COM16	13-6, 80-88	O	LCD common output pin (1/8, 1/16, 1/17 duty can be selected by software)
SEG0-SEG39	5-2, 127-99, 95-89	O	LCD segment output pin
BZ	17	O	Sound output pin
SVD	66	I	SVD external voltage input pin
RESET	28	I	Initial reset input pin
TEST	29	I	Testing input pin

■ ELECTRICAL CHARACTERISTICS

● Absolute Maximum Ratings

(VSS=0V)

Rating	Symbol	Value	Unit
Supply voltage	VDD	-0.5 to 7.0	V
Input voltage (1)	VI	-0.5 to VDD + 0.3	V
Input voltage (2)	VIosc	-0.5 to VD1 + 0.3	V
Permissible total output current *1	ΣIvDD	10	mA
Operating temperature	Topr	-20 to 70	°C
Storage temperature	Tstg	-65 to 150	°C
Soldering temperature / Time	Tsol	260°C, 10sec (lead section)	-
Permissible dissipation *2	Pd	250	mW

*1: The permissible total output current is the sum total of the current (average current) that simultaneously flows from the output pins (or is draw in).

*2: In case of plastic package (QFP8-128pin, QFP15-128pin).

● Recommended Operating Conditions

(Ta=-20 to 70°C)

Condition	Symbol	Remark	Min.	Typ.	Max.	Unit
Supply voltage	VDD	VSS=0V	1.8	3.0	6.4	V
		OSC3 oscillation OFF	2.2	3.0	6.4	V
		OSC1 CR oscillation OSC3 oscillation ON	2.2	3.0	6.4	V
Oscillation frequency	fosc1	Crystal oscillation	-	32.768	-	kHz
		CR oscillation	40	60	80	kHz
	fosc3	Duty 50±5%, VDC="1", VDD=2.2 to 6.5V	50	1,000	1,200	kHz
SVD terminal input voltage	SVD	VSS=0V, SVD≤VDD	0		6.4	V

● DC Characteristics

(Unless otherwise specified: V_{DD}=3.0V, V_{SS}=0V, f_{osc1}=32.768kHz, T_a=25°C, V_{D1}/V_{C1}/V_{C2}/V_{C4}/V_{C5} are internal voltage, C₁–C₈=0.2μF)

Characteristic	Symbol	Condition	Min.	Typ.	Max.	Unit
High level input voltage (1)	V _{IH1}	K00–03, K10–13 P00–03, P10–13, P20–23	0.8•V _{DD}		V _{DD}	V
High level input voltage (2)	V _{IH2}	RESET, TEST	0.9•V _{DD}		V _{DD}	V
Low level input voltage (1)	V _{IL1}	K00–03, K10–13 P00–03, P10–13, P20–23	0		0.2•V _D	V
Low level input voltage (2)	V _{IL2}	RESET, TEST	0		0.1•V _{DD}	V
High level input current	I _{IH}	V _{IH} =3.0V K00–03, K10–13 P00–03, P10–13, P20–23 RESET, TEST	0		0.5	μA
Low level input current (1)	I _{IL1}	V _{IL1} =V _{SS} No pull up K00–03, K10–13 P00–03, P10–13, P20–23 RESET, TEST	-0.5		0	μA
Low level input current (2)	I _{IL2}	V _{IL2} =V _{SS} With pull up K00–03, K10–13 P00–03, P10–13, P20–23 RESET, TEST	-16	-10	-6	μA
High level output current (1)	I _{OH1}	V _{OH1} =0.9•V _{DD} R00–03, R10–13, R20–23 P00–03, P10–13, P20–23			-0.9	mA
High level output current (2)	I _{OH2}	V _{OH2} =0.9•V _{DD} BZ			-0.9	mA
Low level output current (1)	I _{OL1}	V _{OL1} =0.1•V _{DD} R00–03, R10–13, R20–23 P00–03, P10–13, P20–23	3.6			mA
Low level output current (2)	I _{OL2}	V _{OL2} =0.1•V _{DD} BZ	3.6			mA
Common output current	I _{OH3}	V _{OH3} =V _{C5} -0.05V COM0–COM16			-30	μA
	I _{OL3}	V _{OL3} =V _{SS} +0.05V	30			μA
Segment output current	I _{OH4}	V _{OH4} =V _{C5} -0.05V SEG0–SEG39			-10	μA
	I _{OL4}	V _{OL4} =V _{SS} +0.05V	10			μA

(Unless otherwise specified: V_{DD}=5.0V, V_{SS}=0V, f_{osc1}=32.768kHz, T_a=25°C, V_{D1}/V_{C1}/V_{C2}/V_{C4}/V_{C5} are internal voltage, C₁–C₈=0.2μF)

Characteristic	Symbol	Condition	Min.	Typ.	Max.	Unit
High level input voltage (1)	V _{IH1}	K00–03, K10–13 P00–03, P10–13, P20–23	0.8•V _{DD}		V _{DD}	V
High level input voltage (2)	V _{IH2}	RESET, TEST	0.9•V _{DD}		V _{DD}	V
Low level input voltage (1)	V _{IL1}	K00–03, K10–13 P00–03, P10–13, P20–23	0		0.2•V _D	V
Low level input voltage (2)	V _{IL2}	RESET, TEST	0		0.1•V _{DD}	V
High level input current	I _{IH}	V _{IH} =5.0V K00–03, K10–13 P00–03, P10–13, P20–23 RESET, TEST	0		0.5	μA
Low level input current (1)	I _{IL1}	V _{IL1} =V _{SS} No pull up K00–03, K10–13 P00–03, P10–13, P20–23 RESET, TEST	-0.5		0	μA
Low level input current (2)	I _{IL2}	V _{IL2} =V _{SS} With pull up K00–03, K10–13 P00–03, P10–13, P20–23 RESET, TEST	-25	-15	-10	μA
High level output current (1)	I _{OH1}	V _{OH1} =0.9•V _{DD} R00–03, R10–13, R20–23 P00–03, P10–13, P20–23			-2.4	mA
High level output current (2)	I _{OH2}	V _{OH2} =0.9•V _{DD} BZ			-2.4	mA
Low level output current (1)	I _{OL1}	V _{OL1} =0.1•V _{DD} R00–03, R10–13, R20–23 P00–03, P10–13, P20–23	9.4			mA
Low level output current (2)	I _{OL2}	V _{OL2} =0.1•V _{DD} BZ	9.4			mA
Common output current	I _{OH3}	V _{OH3} =V _{C5} -0.05V COM0–COM16			-30	μA
	I _{OL3}	V _{OL3} =V _{SS} +0.05V	30			μA
Segment output current	I _{OH4}	V _{OH4} =V _{C5} -0.05V SEG0–SEG39			-10	μA
	I _{OL4}	V _{OL4} =V _{SS} +0.05V	10			μA

● Analog Circuit Characteristics

(Unless otherwise specified: V_{DD}=3.0V, V_{SS}=0V, f_{osc1}=32.768kHz, C_G=25pF, T_a=25°C, V_{D1}/V_{C1}/V_{C2}/V_{C4}/V_{C5} are internal voltage, C₁–C₈=0.2μF)

Characteristic	Symbol	Condition	Min.	Typ.	Max.	Unit			
LCD drive voltage (when V _{C1} standard is selected)	V _{C1}	Connect 1MΩ load resistor between V _{SS} and V _{C1} (No panel load)	LC0-3="0"	Typ.×0.88	0.975	Typ.×1.12	V		
			LC0-3="1"		0.990				
			LC0-3="2"		1.005				
			LC0-3="3"		1.020				
			LC0-3="4"		1.035				
			LC0-3="5"		1.050				
			LC0-3="6"		1.065				
			LC0-3="7"		1.080				
			LC0-3="8"		1.095				
			LC0-3="9"		1.110				
			LC0-3="10"		1.125				
			LC0-3="11"		1.140				
			LC0-3="12"		1.155				
			LC0-3="13"		1.170				
			LC0-3="14"		1.185				
				1.200					
	V _{C2}	Connect 1MΩ load resistor between V _{SS} and V _{C2} (No panel load)	2•V _{C1}		2•V _{C1} ×0.9	V			
	V _{C4}	Connect 1MΩ load resistor between V _{SS} and V _{C4} (No panel load)	3•V _{C1}		3•V _{C1} ×0.9	V			
	V _{C5}	Connect 1MΩ load resistor between V _{SS} and V _{C5} (No panel load)	4•V _{C1}		4•V _{C1} ×0.9	V			
LCD drive voltage (when V _{C2} standard is selected)	V _{C1}	Connect 1MΩ load resistor between V _{SS} and V _{C1} (No panel load)	1/2•V _{C2}		1/2•V _{C2} ×0.95	V			
			V _{C2}	Connect 1MΩ load resistor between V _{SS} and V _{C2} (No panel load)	LC0-3="0"	Typ.×0.88	1.95	Typ.×1.12	V
					LC0-3="1"		1.98		
					LC0-3="2"		2.01		
					LC0-3="3"		2.04		
					LC0-3="4"		2.07		
					LC0-3="5"		2.10		
					LC0-3="6"		2.13		
					LC0-3="7"		2.16		
					LC0-3="8"		2.19		
					LC0-3="9"		2.22		
					LC0-3="10"		2.25		
					LC0-3="11"		2.28		
					LC0-3="12"		2.31		
					LC0-3="13"		2.34		
LC0-3="14"	2.37								
LC0-3="15"	2.40								
	V _{C4}	Connect 1MΩ load resistor between V _{SS} and V _{C4} (No panel load)	3/2•V _{C2}		3/2•V _{C2} ×0.95	V			
	V _{C5}	Connect 1MΩ load resistor between V _{SS} and V _{C5} (No panel load)	2•V _{C2}		2•V _{C2} ×0.95	V			
SVD voltage	V _{SVD1}	SVDS0-3="0" (internal)	1.75	1.85	1.95	V			
			SVDS0-3="1"	1.80	1.90	2.00	V		
			SVDS0-3="2"	1.90	2.00	2.10	V		
			SVDS0-3="3"	2.00	2.10	2.20	V		
			SVDS0-3="4"	2.10	2.20	2.30	V		
			SVDS0-3="5"	2.20	2.30	2.40	V		
			SVDS0-3="6"	2.30	2.40	2.50	V		
			SVDS0-3="7"	2.40	2.50	2.60	V		
			SVDS0-3="8"	2.50	2.60	2.70	V		
			SVDS0-3="9"	2.60	2.70	2.80	V		
			SVDS0-3="10"	2.70	2.80	2.90	V		
			SVDS0-3="11"	2.80	2.90	3.00	V		
			SVDS0-3="12"	2.90	3.00	3.10	V		
			SVDS0-3="13"	3.00	3.10	3.20	V		
			SVDS0-3="14"	3.10	3.20	3.30	V		
SVDS0-3="15"	3.20	3.30	3.40	V					
SVD voltage (external) *1	V _{SVD2}	SVDS0-3="0" (external)	0.95	1.05	1.15	V			
SVD circuit response time	t _{SVD}				100	μS			

*1; Please input the voltage, which is within the range between V_{SS} and V_{DD}, into the SVD terminal.

● Current Consumption

(Unless otherwise specified: V_{DD}=3.0V, V_{SS}=0V, f_{OSC1}=32.768kHz, C_G=25pF, T_a=25°C, V_{D1}/V_{C1}/V_{C2}/V_{C4}/V_{C5} are internal voltage, C₁–C₈=0.2μF)

Characteristic	Symbol	Condition	Min.	Typ.	Max.	Unit	
Current consumption	I _{OP}	During HALT (32kHz crystal oscillation), LCD power OFF *1, *2, *3		0.8	2.0	μA	
		During HALT (32kHz crystal oscillation), LCD power ON (V _{C1} standard) *1, *2, *3		6.5	12.0	μA	
		During HALT (32kHz crystal oscillation), LCD power ON (V _{C2} standard) *1, *2, *3		4.5	8.0	μA	
		During HALT (60kHz CR oscillation), LCD power OFF *1, *3		21	54	μA	
		During HALT (60kHz CR oscillation), LCD power ON (V _{C1} standard) *1, *3		31	68	μA	
		During HALT (60kHz CR oscillation), LCD power ON (V _{C2} standard) *1, *3		26	61	μA	
		During execution (32kHz crystal oscillation), LCD power ON (V _{C1} standard) *1, *2, *3		10	19	μA	
		During execution (60kHz CR oscillation), LCD power ON (V _{C1} standard) *1, *3		48	90	μA	
		During execution (1MHz ceramic oscillation), LCD power ON (V _{C1} standard) *1		270	530	μA	
		During execution (900kHz CR oscillation), LCD power ON (V _{C1} standard) *1		290	530	μA	
		SVD circuit current (during supply voltage detection) V _{DD} =1.85 to 6.4V		2.0		10.0	μA
		SVD circuit current (during external voltage detection) V _{DD} =1.85 to 6.4V		0.5		3.0	μA

*1: No panel load. The SVD circuit is OFF.

*2: V_{DC}="0"

*3: OSC="0"

● Oscillation Characteristics

The oscillation characteristics change depending on the conditions (components used, board pattern, etc.). Use the following characteristics as reference values.

OSC1 crystal oscillation circuit

(Unless otherwise specified: V_{DD}=3.0V, V_{SS}=0V, f_{OSC1}=32.768kHz, C_G=25pF, C_D=built-in, T_a=25°C)

Characteristic	Symbol	Condition	Min.	Typ.	Max.	Unit
Oscillation start voltage	V _{sta}	t _{sta} ≤3sec (V _{DD})	1.8			V
Oscillation stop voltage	V _{stp}	t _{stp} ≤10sec (V _{DD})	1.8			V
Built-in capacitance (drain)	C _D	Including the parasitic capacity inside the IC (in chip)		14		pF
Frequency/voltage deviation	∂f/∂V	V _{DD} =0.9 to 6.4V	with V _{DC} switching		5	ppm
			without V _{DC} switching		10	
Frequency/IC deviation	∂f/∂IC		-10		10	ppm
Frequency adjustment range	∂f/∂C _G	C _G =5 to 25pF	30	40		ppm
Harmonic oscillation start voltage	V _{hho}	C _G =5pF (V _{DD})	6.4			V
Permitted leak resistance	R _{leak}	Between OSC1 and V _{SS}	200			MΩ

OSC1 CR oscillation circuit

(Unless otherwise specified: V_{DD}=3.0V, V_{SS}=0V, R_{CR1}=510kΩ, T_a=25°C)

Characteristic	Symbol	Condition	Min.	Typ.	Max.	Unit
Oscillation frequency dispersion	f _{OSC1}		-30	60kHz	30	%
Oscillation start voltage	V _{sta}	(V _{DD})	2.2			V
Oscillation start time	t _{sta}	V _{DD} =2.2 to 6.4V			3	mS
Oscillation stop voltage	V _{stp}	(V _{DD})	2.2			V

OSC3 CR oscillation circuit

(Unless otherwise specified: V_{DD}=3.0V, V_{SS}=0V, R_{CR2}=40.2kΩ, T_a=25°C)

Characteristic	Symbol	Condition	Min.	Typ.	Max.	Unit
Oscillation frequency dispersion	f _{OSC3}		-30	900kHz	30	%
Oscillation start voltage	V _{sta}	(V _{DD})	2.2			V
Oscillation start time	t _{sta}	V _{DD} =2.2 to 6.4V			3	mS
Oscillation stop voltage	V _{stp}	(V _{DD})	2.2			V

OSC3 ceramic oscillation circuit

(Unless otherwise specified: V_{DD}=3.0V, V_{SS}=0V, Ceramic oscillation: 1MHz, C_{Gc}=C_{Dc}=100pF, T_a=25°C)

Characteristic	Symbol	Condition	Min.	Typ.	Max.	Unit
Oscillation start voltage	V _{sta}	(V _{DD})	2.2			V
Oscillation start time	t _{sta}	V _{DD} =2.2 to 6.4V			5	mS
Oscillation stop voltage	V _{stp}	(V _{DD})	2.2			V

■ BASIC EXTERNAL CONNECTION DIAGRAM

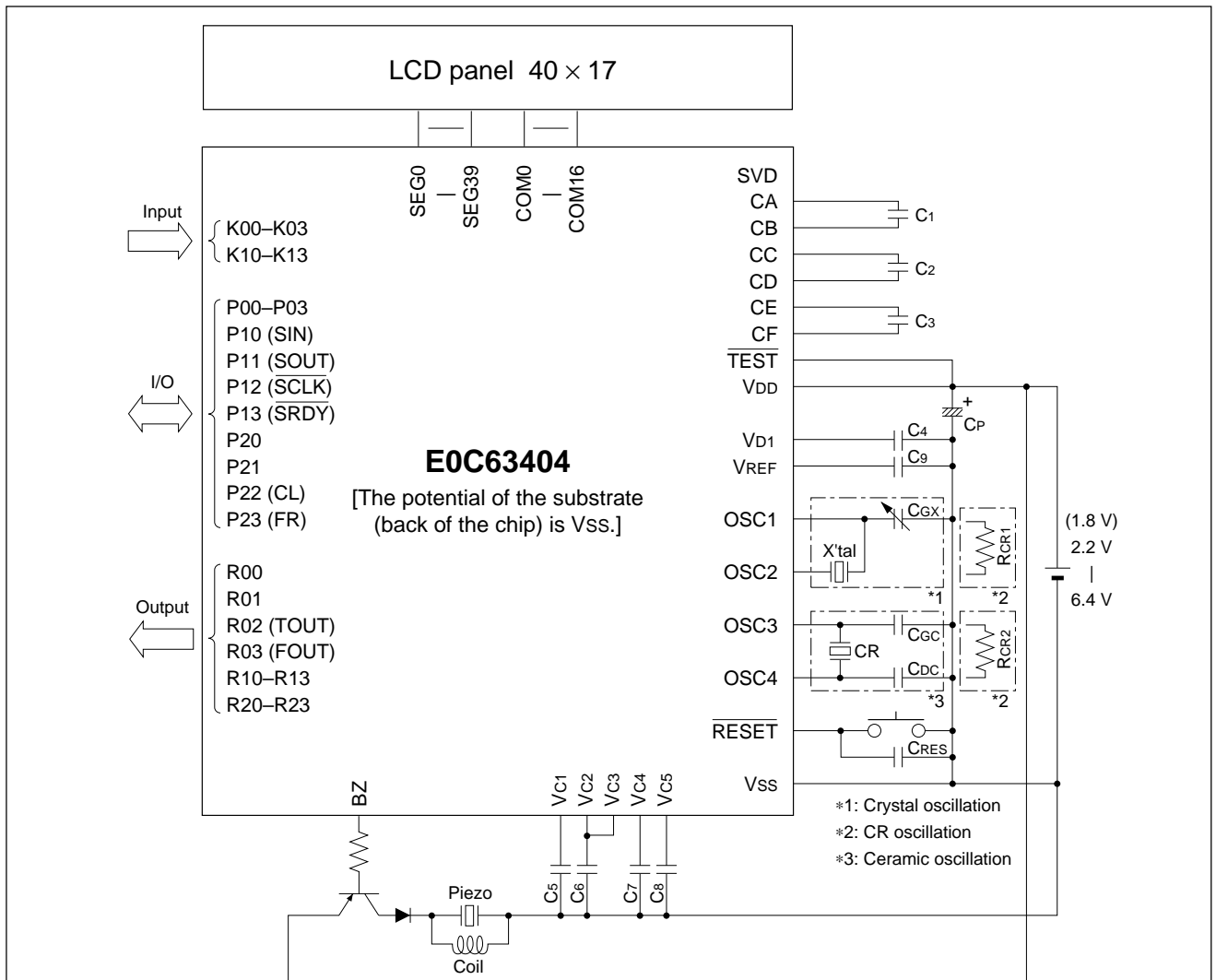

X'tal	Crystal oscillator	32.768 kHz, C _i (Max.) = 34 kΩ
CGX	Trimmer capacitor	5–25 pF
RCR1	Resistor for OSC1 CR oscillation	510 kΩ (60 kHz)
CR	Ceramic oscillator	1 MHz (3.0 V)
CGC	Gate capacitor	100 pF
CDC	Drain capacitor	100 pF
RCR2	Resistor for OSC3 CR oscillation	40.2 kΩ (1 MHz)
C1–C8	Capacitor	0.2 μF
C9	Capacitor	0.1 μF
CP	Capacitor	3.3 μF
CRES	RESET terminal capacitor	0.1 μF

Note: The above table is simply an example, and is not guaranteed to work.

NOTICE

No part of this material may be reproduced or duplicated in any form or by any means without the written permission of Seiko Epson. Seiko Epson reserves the right to make changes to this material without notice. Seiko Epson does not assume any liability of any kind arising out of any inaccuracies contained in this material or due to its application or use in any product or circuit and, further, there is no representation that this material is applicable to products requiring high level reliability, such as, medical products. Moreover, no license to any intellectual property rights is granted by implication or otherwise, and there is no representation or warranty that anything made in accordance with this material will be free from any patent or copyright infringement of a third party. This material or portions thereof may contain technology or the subject relating to strategic products under the control of the Foreign Exchange and Foreign Trade Control Law of Japan and may require an export license from the Ministry of International Trade and Industry or other approval from another government agency.

All product names mentioned herein are trademarks and/or registered trademarks of their respective companies.

©Seiko Epson Corporation 1998 All rights reserved.

SEIKO EPSON CORPORATION**ELECTRONIC DEVICES MARKETING DIVISION****Electronic Device Marketing Department
IC Marketing & Engineering Group**

421-8, Hino, Hino-shi, Tokyo 191-8501, JAPAN
Phone: +81-(0)42-587-5816 Fax: +81-(0)42-587-5624

ED International Marketing Department I (Europe & U.S.A.)

421-8, Hino, Hino-shi, Tokyo 191-8501, JAPAN
Phone: +81-(0)42-587-5812 Fax: +81-(0)42-587-5564

ED International Marketing Department II (Asia)

421-8, Hino, Hino-shi, Tokyo 191-8501, JAPAN
Phone: +81-(0)42-587-5814 Fax: +81-(0)42-587-5110

Electric Device Information of EPSON WWW server

<http://www.epson.co.jp>

