

# E0C332L01

## 32-bit Single Chip Microcomputer

- High-speed 32-bit RISC Core
- Multiply Accumulation
- Built-in LCD Controller
- 10-bit ADC
- Built-in ROM and RAM
- Twin-clock Oscillator

### ■ DESCRIPTION

The E0C332L01 is a CMOS 32-bit microcomputer composed of a CMOS 32-bit RISC core, ROM, RAM, DMA, timers, SIO, PLL, LCDC and other circuits. The E0C332L01 can be operated with high speed and spend little current. With the ADC, PWM and the MAC function, the E0C332L01 is suitable for voice applications and PDAs.

### ■ FEATURES

- CMOS LSI 32-bit parallel processing ..... E0C33000 RISC core
- Main clock ..... 50MHz (Max., up to 12.5MHz external clock input)
- Sub clock ..... 32.768kHz (Typ., crystal)
- Instruction set ..... 16-bit fixed length, 105 instructions  
(MAC instruction is included, 2 cycles)
- Internal ROM size ..... 128K bytes
- Internal RAM size ..... Data RAM : 8K bytes  
VRAM : 40K bytes
- LCD controller ..... SED1375 equivalent  
4/8-bit monochrome/color LCD interface  
Active-matrix TFT/D-TFD interface  
1, 2 or 4 bits/pixel; 2, 4, or 16-level gray-scale display  
1, 2, 4 or 8 bits/pixel; 2, 4, 16 or 256 color display
- Clock timer ..... 1 channel
- Programmable timer ..... 8 bits × 4 channels and 16 bits × 6 channels
- PWM timer ..... Realized with a 16-bit programmable timer
- Watchdog timer ..... Realized with a 16-bit programmable timer
- Serial interface ..... 2 channels  
Clock synchronization type and asynchronization type are selectable. Usable as an infrared ray (IrDA) interface.
- 10-bit A/D converter ..... Successive approximation type, 8 input channels
- High-speed DMA ..... 4 channels
- Intelligent DMA ..... 128 channels
- I/O port ..... Input port : 13 bits  
I/O port : 29 bits  
Pins are shared with the inputs and outputs of built-in peripheral circuits.
- Interrupt controller ..... External interrupts : 6 types  
Internal interrupts : 29 types
- External bus interface ..... 24-bit address bus, 16-bit data bus, 7 chip enable pins  
DRAM and burst ROM may be connected directly.
- Shipping form ..... QFP18-176pin or chip
- Supply voltage ..... Core voltage : 1.8 to 3.6V  
I/O voltage : 1.8 to 5.5V
- Power consumption ..... HALT state : TBD (3.3V, 32.768kHz)  
RUN state : TBD (3.3V, 50MHz)

# E0C332L01

## ■ BLOCK DIAGRAM

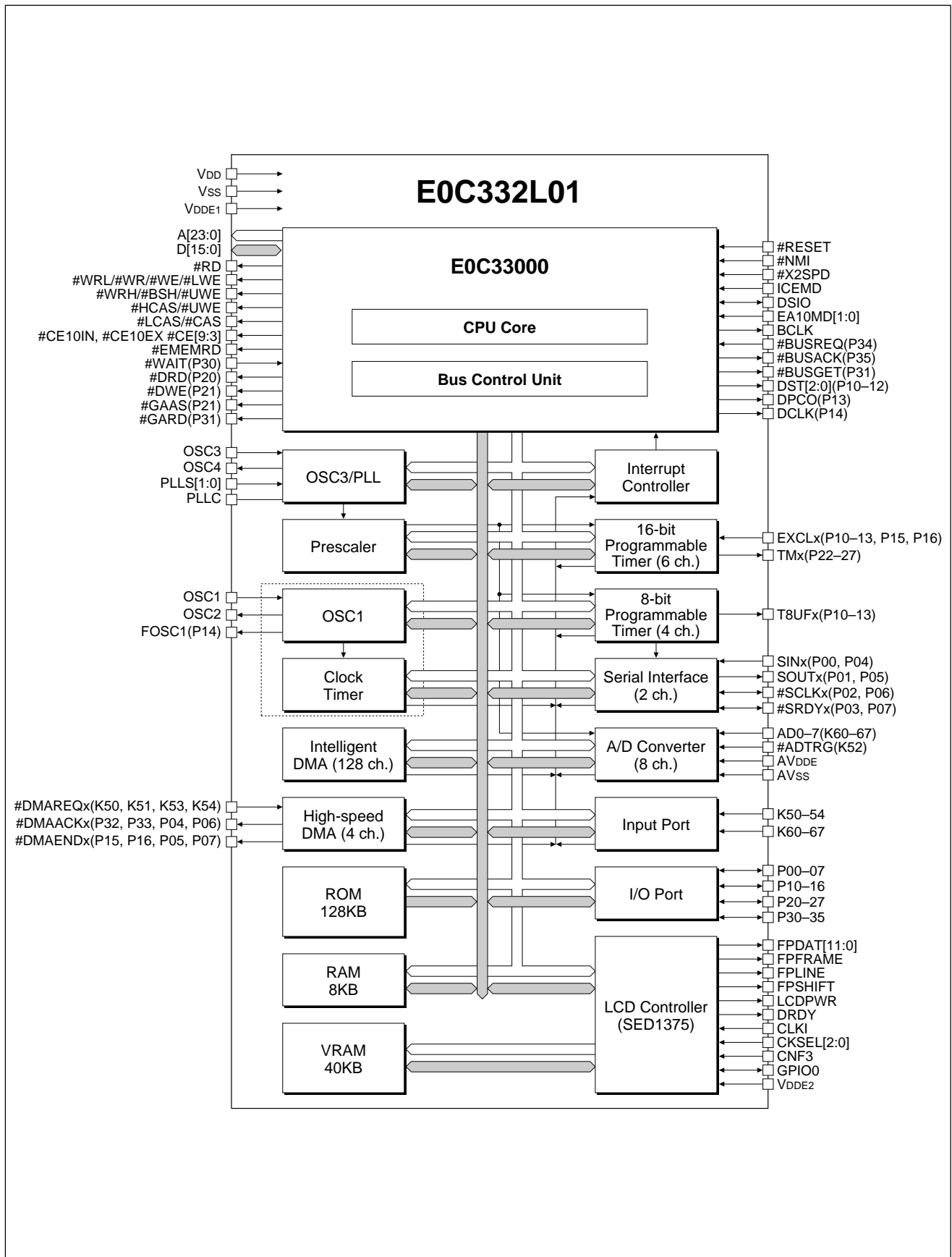

## ■ PIN LAYOUT

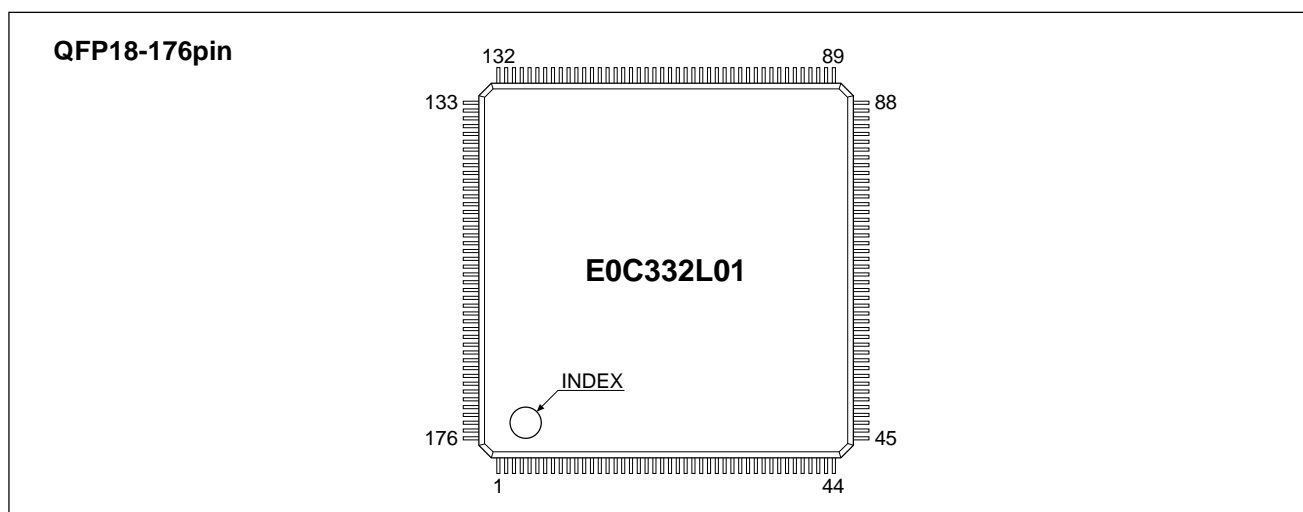

No.	Pin name	No.	Pin name	No.	Pin name	No.	Pin name
1	A23	45	D2	89	N.C.	133	P21/#DWE/#GAAS
2	A22	46	D1	90	Vss	134	P20/#DRD
3	A21	47	D0	91	GPIO0	135	P16/EXCL5/#DMAEND1
4	A20	48	Vss	92	FPDAT11/GPIO4/INVERSE	136	P15/EXCL4/#DMAEND0
5	VdDE1	49	BCLK	93	FPDAT10/GPIO3	137	VdDE1
6	A19	50	#EMEMRD	94	FPDAT9/GPIO2	138	P14/FOSC1/DCLK
7	A18	51	#RD	95	VdDE2	139	P13/EXCL3/T8UF3/DPCO
8	A17	52	#WRL/#WR/#WE/#LWE	96	FPDAT8/GPIO1	140	P12/EXCL2/T8UF2/DST2
9	A16	53	#WRH/#BSH/#UWE	97	FPSHIFT	141	P11/EXCL1/T8UF1/DST1
10	A15	54	VdDE1	98	FPDAT7	142	P10/EXCL0/T8UF0/DST0
11	Vss	55	#CE10EX	99	FPDAT6	143	Vss
12	A14	56	#CE10IN	100	FPDAT5	144	P07/#SRDY1/#DMAEND3
13	A13	57	#CE3	101	Vdd	145	P06/#SCLK1/DMAACK3
14	A12	58	Vss	102	FPDAT4	146	P05/SOUT1/#DMAEND2
15	A11	59	K67/AD7	103	FPDAT3	147	P04/SIN1/#DMAACK2
16	A10	60	K66/AD6	104	FPDAT2	148	Vdd
17	VDD	61	K65/AD5	105	FPDAT1	149	OSC2
18	A9	62	AVdDE	106	Vss	150	OSC1
19	A8	63	K64/AD4	107	FPDAT0	151	Vss
20	A7	64	K63/AD3	108	FPLINE	152	P03/#SRDY0
21	A6	65	K62/AD2	109	FPFRAME	153	P02/#SCLK0
22	A5	66	AVss	110	DRDY/MOD/FPSHIFT2	154	P01/SOUT0
23	Vss	67	K61/AD1	111	VdDE2	155	P00/SIN0
24	A4	68	K60/AD0	112	LCDPWR	156	CNF3
25	A3	69	K54/#DMAREQ3	113	N.C.	157	CKSEL2
26	A2	70	K53/#DMAREQ2	114	N.C.	158	CKSEL1
27	A1	71	K52/#ADTRG	115	N.C.	159	CKSEL0
28	A0/#BSL	72	Vdd	116	N.C.	160	VdDE1
29	VdDE1	73	K51/#DMAREQ1	117	N.C.	161	CLKI
30	D15	74	K50/#DMAREQ0	118	Vss	162	ICEMD
31	D14	75	#LCAS/#CAS	119	P35/#BUSACK	163	Vss
32	D13	76	#HCAS/#UWE	120	P34/#BUSREQ/#CE6	164	OSC4
33	D12	77	#CE9/#CE17	121	P33/#DMAACK1	165	OSC3
34	D11	78	Vss	122	P32/#DMAACK0	166	EA10MD1
35	Vss	79	#CE8/#RAS1/#CE14/#RAS3	123	P31/#BUSGET/#GARD	167	EA10MD0
36	D10	80	#CE7/#RAS0/#CE13/#RAS2	124	P30/#WAIT/#CE4&5	168	#X2SPD
37	D9	81	#CE5/#CE15	125	Vdd	169	Vdd
38	D8	82	#CE4/#CE11	126	P27/TM5	170	PLLS1
39	D7	83	#CE6	127	P26/TM4	171	PLLS0
40	D6	84	VdDE1	128	P25/TM3	172	#NMI
41	VDD	85	N.C.	129	P24/TM2	173	Vss
42	D5	86	N.C.	130	P23/TM1	174	PLL
43	D4	87	N.C.	131	Vss	175	#RESET
44	D3	88	N.C.	132	P22/TM0	176	DSIO

# E0C332L01

## NOTICE:

No part of this material may be reproduced or duplicated in any form or by any means without the written permission of Seiko Epson. Seiko Epson reserves the right to make changes to this material without notice. Seiko Epson does not assume any liability of any kind arising out of any inaccuracies contained in this material or due to its application or use in any product or circuit and, further, there is no representation that this material is applicable to products requiring high level reliability, such as, medical products. Moreover, no license to any intellectual property rights is granted by implication or otherwise, and there is no representation or warranty that anything made in accordance with this material will be free from any patent or copyright infringement of a third party. This material or portions thereof may contain technology or the subject relating to strategic products under the control of the Foreign Exchange and Foreign Trade Law of Japan and may require an export license from the Ministry of International Trade and Industry or other approval from another government agency.

© Seiko Epson Corporation 2000 All right reserved.

## SEIKO EPSON CORPORATION

ELECTRONIC DEVICES MARKETING DIVISION

IC Marketing & Engineering Group

### ED International Marketing Department I (Europe & U.S.A.)

421-8, Hino, Hino-shi, Tokyo 191-8501, JAPAN  
Phone : 042-587-5812 FAX : 042-587-5564

### ED International Marketing Department II (Asia)

421-8, Hino, Hino-shi, Tokyo 191-8501, JAPAN  
Phone : 042-587-5814 FAX : 042-587-5110

■ EPSON Electronic Devices Website

<http://www.epson.co.jp/device/>

