

4-bit Single Chip Microcomputer

- 4-bit E0C63000 Core CPU
- Built-in Dot-matrix LCD Driver
- High Speed Instruction Cycle (2-6CPI)

■ DESCRIPTION

The E0C63455 is a CMOS 4-bit microcomputer composed of a CMOS 4-bit core CPU, ROM, RAM, dot-matrix type LCD driver, serial interface and counters. And the E0C63455 can be operated with high speed and spend little current.

■ FEATURES

- CMOS LSI 4-bit parallel processing E0C63000 core CPU
- Main clock 32.768kHz (Typ.) crystal / 60kHz (Typ.) CR
- Sub clock 1.8MHz (Typ.) CR / 4MHz (Max.) ceramic
- Instruction set 46 types (411 instructions with all), 8 types addressing mode
- Instruction execution time 32.768kHz : 61μsec, 122μsec, 183μsec
4MHz : 0.5μsec, 1.0μsec, 1.5μsec
- ROM capacity Code ROM : 4,096 words × 13 bits
Data ROM : 2,048 words × 4 bits
- RAM capacity Data memory : 1,024 words × 4 bits
Display memory : 480 bits (120 words × 4 bits)
- I/O port I : 4 bits (Pull-up resistors may be supplemented)
O : 4 bits (It is possible to switch the 2 bits to special output)
I/O : 8 bits (It is possible to switch the 4 bits to serial I/F input/output)
- LCD driver 60 segments × 8 commons
- Clock timer 1 ch.
- Stopwatch timer 1 ch.
- Programmable timer 8 bits × 2 ch.
- Watchdog timer Built-in
- Serial interface 8-bit clock synchronous
- Sound generator With envelope and 1-shot output functions
- Interrupts External : Kye interrupt 1 system
Internal : Clock timer interrupt 4 systems
: Stopwatch timer interrupt 2 systems
: Programmable timer interrupt 2 systems
: Serial interface interrupt 1 system
- Power supply voltage 2.2 to 6.4V (Min. 1.8V with OSC1 crystal oscillation circuit only)
- Operating temperature range -20°C to 70°C
- Current consumption 1.0μA (32.768kHz, LCD OFF, 3.0V, HALT)
4.0μA (32.768kHz, LCD ON, 3.0V, RUN)
1,000μA (4MHz, LCD ON, 3.0V, RUN)
- Package QFP5-128pin / QFP8-128pin (plastic), Die form

E0C63455

■ BLOCK DIAGRAM

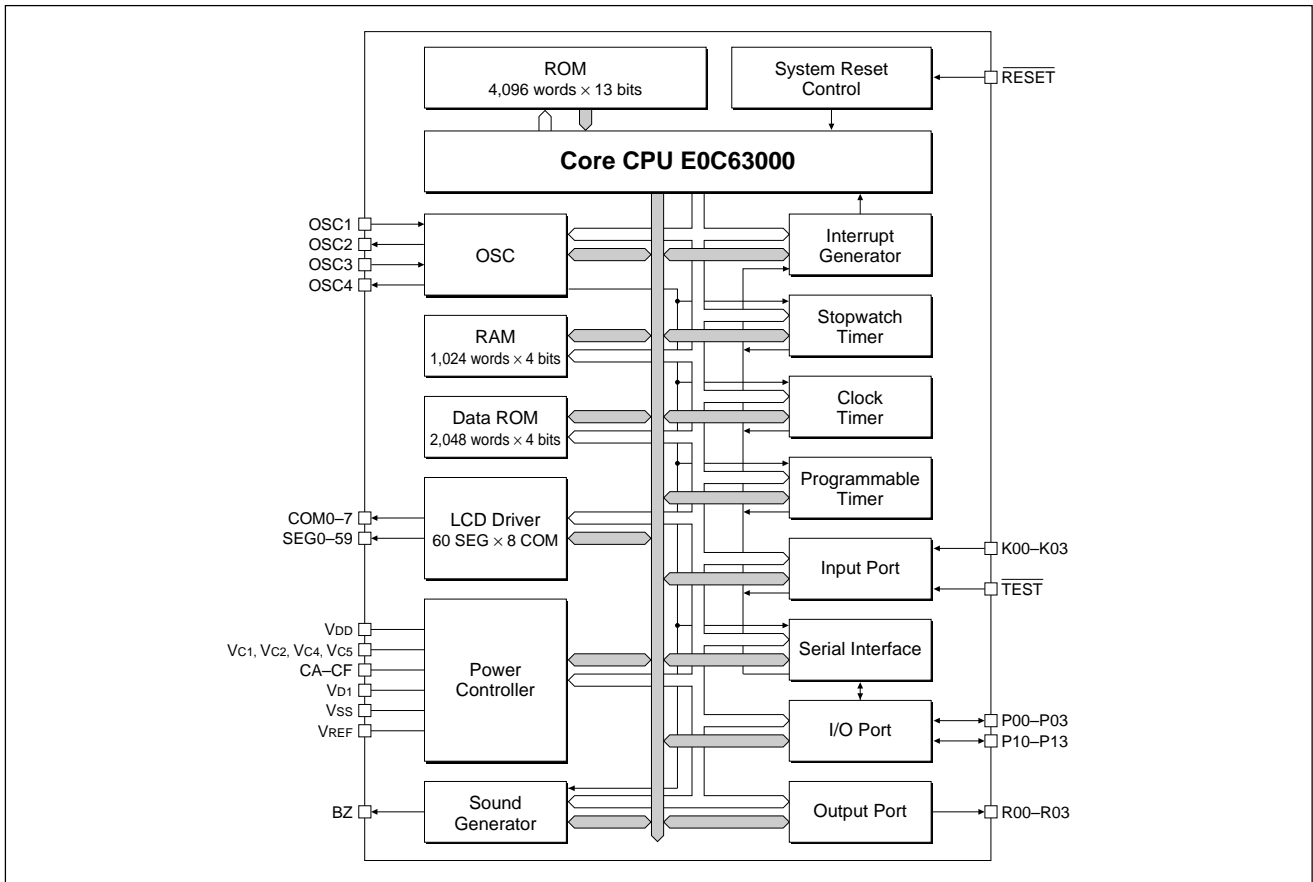

■ PIN CONFIGURATION

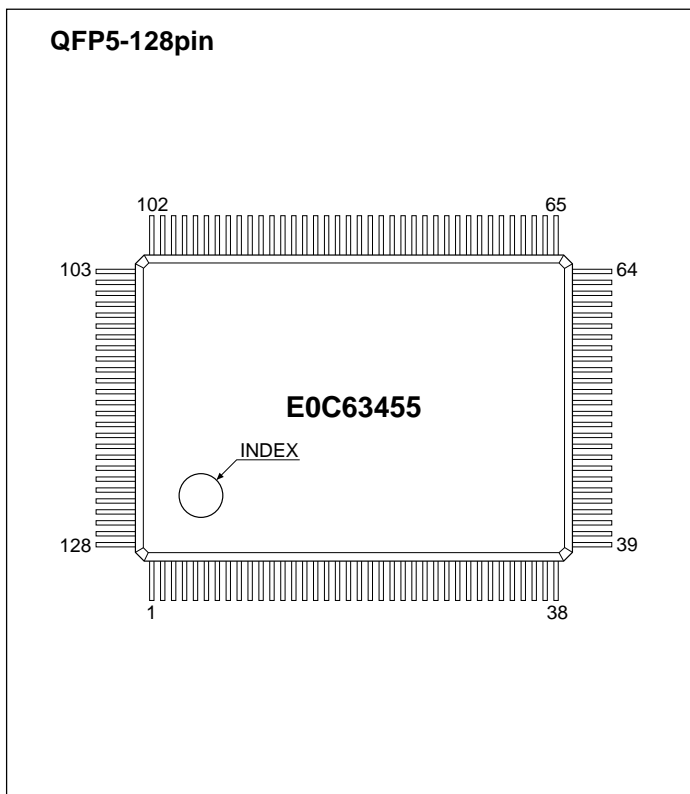

No.	Pin name	No.	Pin name	No.	Pin name	No.	Pin name
1	SEG12	33	N.C.	65	N.C.	97	SEG41
2	SEG11	34	N.C.	66	N.C.	98	N.C.
3	N.C.	35	N.C.	67	N.C.	99	N.C.
4	N.C.	36	N.C.	68	N.C.	100	N.C.
5	N.C.	37	N.C.	69	Vc1	101	SEG40
6	N.C.	38	N.C.	70	Vc2	102	SEG39
7	N.C.	39	N.C.	71	Vc4	103	SEG38
8	SEG10	40	N.C.	72	Vc5	104	SEG37
9	SEG9	41	OSC3	73	CF	105	SEG36
10	SEG8	42	OSC4	74	CE	106	SEG35
11	SEG7	43	VDD	75	CD	107	SEG34
12	SEG6	44	RESET	76	CC	108	SEG33
13	SEG5	45	TEST	77	CB	109	SEG32
14	SEG4	46	VREF	78	CA	110	SEG31
15	SEG3	47	R03	79	SEG59	111	SEG30
16	SEG2	48	R02	80	SEG58	112	SEG29
17	SEG1	49	R01	81	SEG57	113	SEG28
18	SEG0	50	R00	82	SEG56	114	SEG27
19	COM7	51	P13	83	SEG55	115	SEG26
20	COM6	52	P12	84	SEG54	116	SEG25
21	COM5	53	P11	85	SEG53	117	SEG24
22	COM4	54	P10	86	SEG52	118	SEG23
23	COM3	55	P03	87	SEG51	119	SEG22
24	COM2	56	P02	88	SEG50	120	SEG21
25	COM1	57	P01	89	SEG49	121	SEG20
26	COM0	58	P00	90	SEG48	122	SEG19
27	BZ	59	K03	91	SEG47	123	SEG18
28	VSS	60	K02	92	SEG46	124	SEG17
29	OSC1	61	K01	93	SEG45	125	SEG16
30	OSC2	62	K00	94	SEG44	126	SEG15
31	Vd1	63	N.C.	95	SEG43	127	SEG14
32	N.C.	64	N.C.	96	SEG42	128	SEG13

N.C. : No Connection

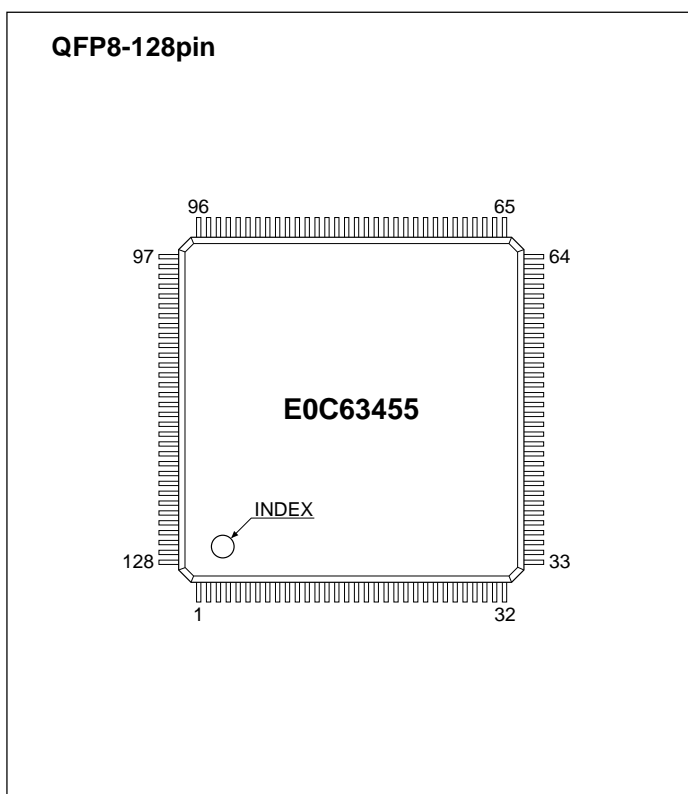

No.	Pin name	No.	Pin name	No.	Pin name	No.	Pin name
1	N.C.	33	N.C.	65	N.C.	97	N.C.
2	N.C.	34	N.C.	66	Vc1	98	SEG40
3	N.C.	35	N.C.	67	Vc2	99	SEG39
4	N.C.	36	N.C.	68	Vc4	100	SEG38
5	SEG10	37	N.C.	69	Vc5	101	SEG37
6	SEG9	38	OSC3	70	CF	102	SEG36
7	SEG8	39	OSC4	71	CE	103	SEG35
8	SEG7	40	V _{DD}	72	CD	104	SEG34
9	SEG6	41	RESET	73	CC	105	SEG33
10	SEG5	42	TEST	74	CB	106	SEG32
11	SEG4	43	V _{REF}	75	CA	107	SEG31
12	SEG3	44	R03	76	SEG59	108	SEG30
13	SEG2	45	R02	77	SEG58	109	SEG29
14	SEG1	46	R01	78	SEG57	110	SEG28
15	SEG0	47	R00	79	SEG56	111	SEG27
16	COM7	48	P13	80	SEG55	112	SEG26
17	COM6	49	P12	81	SEG54	113	SEG25
18	COM5	50	P11	82	SEG53	114	SEG24
19	COM4	51	P10	83	SEG52	115	SEG23
20	COM3	52	P03	84	SEG51	116	SEG22
21	COM2	53	P02	85	SEG50	117	SEG21
22	COM1	54	P01	86	SEG49	118	SEG20
23	COM0	55	P00	87	SEG48	119	SEG19
24	BZ	56	K03	88	SEG47	120	SEG18
25	V _{SS}	57	K02	89	SEG46	121	SEG17
26	OSC1	58	K01	90	SEG45	122	SEG16
27	OSC2	59	K00	91	SEG44	123	SEG15
28	V _{D1}	60	N.C.	92	SEG43	124	SEG14
29	N.C.	61	N.C.	93	SEG42	125	SEG13
30	N.C.	62	N.C.	94	SEG41	126	SEG12
31	N.C.	63	N.C.	95	N.C.	127	SEG11
32	N.C.	64	N.C.	96	N.C.	128	N.C.

N.C. : No Connection

PIN DESCRIPTION

Pin name	Pin No.		In/Out	Function
	QFP5-128pin	QFP8-128pin		
V _{DD}	43	40	–	Power (+) supply pin
V _{SS}	28	25	–	Power (–) supply pin
V _{D1}	31	28	–	Oscillation/internal logic system regulated voltage output pin
V _{C1} , V _{C2} , V _{C4} , V _{C5}	69, 70, 71, 72	66, 67, 68, 69	–	LCD system power supply pin 1/4 bias generated internally
V _{REF}	46	43	O	LCD system power supply testing pin
CA–CF	78–73	75–70	–	LCD system boosting/reducing capacitor connecting pin
OSC1	29	26	I	Crystal or CR oscillation input pin (selected by mask option)
OSC2	30	27	O	Crystal or CR oscillation output pin (selected by mask option)
OSC3	41	38	I	Ceramic or CR oscillation input pin (selected by mask option)
OSC4	42	39	O	Ceramic or CR oscillation output pin (selected by mask option)
K00–K03	62–59	59–56	I	Input port
P00–P03	58–55	55–52	I/O	I/O port
P10–P13	54–51	51–48	I/O	I/O port (switching to serial I/F input/output is possible by software)
R00	50	47	O	Output port
R01	49	46	O	Output port
R02	48	45	O	Output port (switching to TOUT signal output is possible by software)
R03	47	44	O	Output port (switching to FOUT signal output is possible by software)
COM0–COM7	26–19	23–16	O	LCD common output pin
SEG0–SEG59	18–8, 2–1, 128–101, 97–79	15–5, 127–98, 94–76	O	LCD segment output pin
BZ	27	24	O	Sound output pin
RESET	44	41	I	Initial reset input pin
TEST	45	42	I	Testing input pin

■ ELECTRICAL CHARACTERISTICS

● Absolute Maximum Ratings

(V_{SS}=0V)

Rating	Symbol	Value	Unit
Supply voltage	V _{DD}	-0.5 to 7.0	V
Input voltage (1)	V _I	-0.5 to V _{DD} + 0.3	V
Input voltage (2)	V _I OSC	-0.5 to V _{D1} + 0.3	V
Permissible total output current *1	ΣI _{VDD}	10	mA
Operating temperature	T _{opr}	-20 to 70	°C
Storage temperature	T _{stg}	-65 to 150	°C
Soldering temperature / time	T _{sol}	260°C, 10sec (lead section)	—
Permissible dissipation *2	P _d	250	mW

*1: The permissible total output current is the sum total of the current (average current) that simultaneously flows from the output pin (or is drawn in).

*2: In case of plastic package.

● Recommended Operating Conditions

(T_a=-20 to 70°C)

Condition	Symbol	Remark	Min.	Typ.	Max.	Unit
Supply voltage	V _{DD}	V _{SS} =0V	1.8	3.0	6.4	V
		OSC3 oscillation OFF	2.2	3.0	6.4	V
		OSC1 CR oscillation OSC3 oscillation ON	2.2	3.0	6.4	V
Oscillation frequency	f _{OSC1}	Crystal oscillation	—	32.768	—	kHz
		CR oscillation	40	60	80	kHz
	f _{OSC3}	CR oscillation		1,800		kHz
		Ceramic oscillation			4,100	kHz

● DC Characteristics

(Unless otherwise specified: V_{DD}=3.0V, V_{SS}=0V, f_{OSC1}=32.768kHz, T_a=25°C, V_{D1}/V_{C1}/V_{C2}/V_{C4}/V_{C5} are internal voltage, C₁–C₈=0.2μF)

Characteristic	Symbol	Condition	Min.	Typ.	Max.	Unit
High level input voltage (1)	V _{IH1}	K00–03, P00–03, P10–13	0.8·V _{DD}		V _{DD}	V
High level input voltage (2)	V _{IH2}	RESET, TEST, P10–13	0.9·V _{DD}		V _{DD}	V
Low level input voltage (1)	V _{IL1}	K00–03, P00–03, P10–13	0		0.2·V _{DD}	V
Low level input voltage (2)	V _{IL2}	RESET, TEST, P10–13	0		0.1·V _{DD}	V
High level input current	I _{IH}	V _{IH} =3.0V K00–03, P00–03, P10–13 RESET, TEST	0		0.5	μA
Low level input current (1)	I _{IL1}	V _{IL1} =V _{SS} No Pull-up K00–03, P00–03, P10–13 RESET, TEST	-0.5		0	μA
Low level input current (2)	I _{IL2}	V _{IL2} =V _{SS} With Pull-up K00–03, P00–03, P10–13 RESET, TEST	-12	-7	-5	μA
High level output current (1)	I _{OH1}	V _{OH1} =0.9·V _{DD} R00–03, P00–03, P10–13			-2	mA
High level output current (2)	I _{OH2}	V _{OH2} =0.9·V _{DD} BZ			-2	mA
Low level output current (1)	I _{OL1}	V _{OL1} =0.1·V _{DD} R00–03, P00–03, P10–13	3			mA
Low level output current (2)	I _{OL2}	V _{OL2} =0.1·V _{DD} BZ	3			mA
Common output current	I _{OH3}	V _{OH3} =V _{C5} -0.05V COM0–7			-25	μA
	I _{OL3}	V _{OL3} =V _{SS} +0.05V	25			μA
Segment output current	I _{OH4}	V _{OH4} =V _{C5} -0.05V SEG0–59			-10	μA
	I _{OL4}	V _{OL4} =V _{SS} +0.05V	10			μA

(Unless otherwise specified: V_{DD}=5.0V, V_{SS}=0V, f_{OSC1}=32.768kHz, T_a=25°C, V_{D1}/V_{C1}/V_{C2}/V_{C4}/V_{C5} are internal voltage, C₁–C₈=0.2μF)

Characteristic	Symbol	Condition	Min.	Typ.	Max.	Unit
High level input voltage (1)	V _{IH1}	K00–03, P00–03, P10–13	0.8·V _{DD}		V _{DD}	V
High level input voltage (2)	V _{IH2}	RESET, TEST, P10–13	0.9·V _{DD}		V _{DD}	V
Low level input voltage (1)	V _{IL1}	K00–03, P00–03, P10–13	0		0.2·V _{DD}	V
Low level input voltage (2)	V _{IL2}	RESET, TEST, P10–13	0		0.1·V _{DD}	V
High level input current	I _{IH}	V _{IH} =5.0V K00–03, P00–03, P10–13 RESET, TEST	0		0.5	μA
Low level input current (1)	I _{IL1}	V _{IL1} =V _{SS} No Pull-up K00–03, P00–03, P10–13 RESET, TEST	-0.5		0	μA
Low level input current (2)	I _{IL2}	V _{IL2} =V _{SS} With Pull-up K00–03, P00–03, P10–13 RESET, TEST	-20	-12	-9	μA
High level output current (1)	I _{OH1}	V _{OH1} =0.9·V _{DD} R00–03, P00–03, P10–13			-5	mA
High level output current (2)	I _{OH2}	V _{OH2} =0.9·V _{DD} BZ			-5	mA
Low level output current (1)	I _{OL1}	V _{OL1} =0.1·V _{DD} R00–03, P00–03, P10–13	7.5			mA
Low level output current (2)	I _{OL2}	V _{OL2} =0.1·V _{DD} BZ	7.5			mA
Common output current	I _{OH3}	V _{OH3} =V _{C5} -0.05V COM0–7			-25	μA
	I _{OL3}	V _{OL3} =V _{SS} +0.05V	25			μA
Segment output current	I _{OH4}	V _{OH4} =V _{C5} -0.05V SEG0–59			-10	μA
	I _{OL4}	V _{OL4} =V _{SS} +0.05V	10			μA

● Analog Circuit Characteristics and Current Consumption

(Unless otherwise specified: $V_{DD}=3.0V$, $V_{SS}=0V$, $f_{osc1}=32.768kHz$, $C_G=25pF$, $R_{CR1}=600k\Omega$, $R_{CR2}=47k\Omega$,
 $T_a=25^\circ C$, $V_{D1}/V_{C1}/V_{C2}/V_{C4}/V_{C5}$ are internal voltage, $C_1-C_8=0.2\mu F$)

Characteristic	Symbol	Condition	Min.	Typ.	Max.	Unit	
LCD drive voltage (when Vc1 standard is selected)	Vc1	Connect 1M Ω load resistor between Vss and Vc1 (without panel load)	LC0-3="0"	Typ. $\times 0.88$	0.975	Typ. $\times 1.12$	V
			LC0-3="1"		0.990		
			LC0-3="2"		1.005		
			LC0-3="3"		1.020		
			LC0-3="4"		1.035		
			LC0-3="5"		1.050		
			LC0-3="6"		1.065		
			LC0-3="7"		1.080		
			LC0-3="8"		1.095		
			LC0-3="9"		1.110		
			LC0-3="10"		1.125		
			LC0-3="11"		1.140		
			LC0-3="12"		1.155		
			LC0-3="13"		1.170		
			LC0-3="14"		1.185		
LC0-3="15"	1.200						
	Vc2	Connect 1M Ω load resistor between Vss and Vc2 (without panel load)	$2 \cdot V_{C1}$ $\times 0.9$		$2 \cdot V_{C1}$	V	
	Vc4	Connect 1M Ω load resistor between Vss and Vc4 (without panel load)	$3 \cdot V_{C1}$ $\times 0.9$		$3 \cdot V_{C1}$	V	
	Vc5	Connect 1M Ω load resistor between Vss and Vc5 (without panel load)	$4 \cdot V_{C1}$ $\times 0.9$		$4 \cdot V_{C1}$	V	
LCD drive voltage (when Vc2 standard is selected)	Vc1	Connect 1M Ω load resistor between Vss and Vc1 (without panel load)	$1/2 \cdot V_{C2}$	Typ. $\times 0.88$	$1/2 \cdot V_{C2}$ $+ 0.1$	Typ. $\times 1.12$	V
			LC0-3="0"		1.95		
			LC0-3="1"		1.98		
			LC0-3="2"		2.01		
			LC0-3="3"		2.04		
			LC0-3="4"		2.07		
			LC0-3="5"		2.10		
			LC0-3="6"		2.13		
			LC0-3="7"		2.16		
			LC0-3="8"		2.19		
			LC0-3="9"		2.22		
			LC0-3="10"		2.25		
			LC0-3="11"		2.28		
			LC0-3="12"		2.31		
			LC0-3="13"		2.34		
LC0-3="14"	2.37						
LC0-3="15"	2.40						
	Vc4	Connect 1M Ω load resistor between Vss and Vc4 (without panel load)	$3/2 \cdot V_{C2}$ $\times 0.95$		$3/2 \cdot V_{C2}$	V	
	Vc5	Connect 1M Ω load resistor between Vss and Vc5 (without panel load)	$2 \cdot V_{C2}$ $\times 0.95$		$2 \cdot V_{C2}$	V	
Current consumption	IOP	During HALT (32kHz crystal), LCD power OFF	*1,*2	1	2	μA	
		During HALT (32kHz crystal), LCD power ON (Vc1 standard)	*1,*2	6	12	μA	
		During HALT (32kHz crystal), LCD power ON (Vc2 standard)	*1,*2	4	8	μA	
		During HALT (60kHz CR), LCD power OFF	*2	23	45	μA	
		During HALT (60kHz CR), LCD power ON (Vc1 standard)	*2	30	60	μA	
		During HALT (60kHz CR), LCD power ON (Vc2 standard)	*2	26	50	μA	
		During execution (32kHz crystal), LCD power ON (Vc1 standard)	*1,*2	10	19	μA	
		During execution (60kHz CR), LCD power ON (Vc1 standard)	*2	45	80	μA	
		During execution (2MHz ceramic), LCD power ON (Vc1 standard)		500	700	μA	
		During execution (4MHz ceramic), LCD power ON (Vc1 standard)		1,000	1,200	μA	
During execution (1,800kHz CR), LCD power ON (Vc1 standard)		700	1,000	μA			

*1: VDC = "0"

*2: OSC = "0"

E0C63455

■ BASIC EXTERNAL CONNECTION DIAGRAM

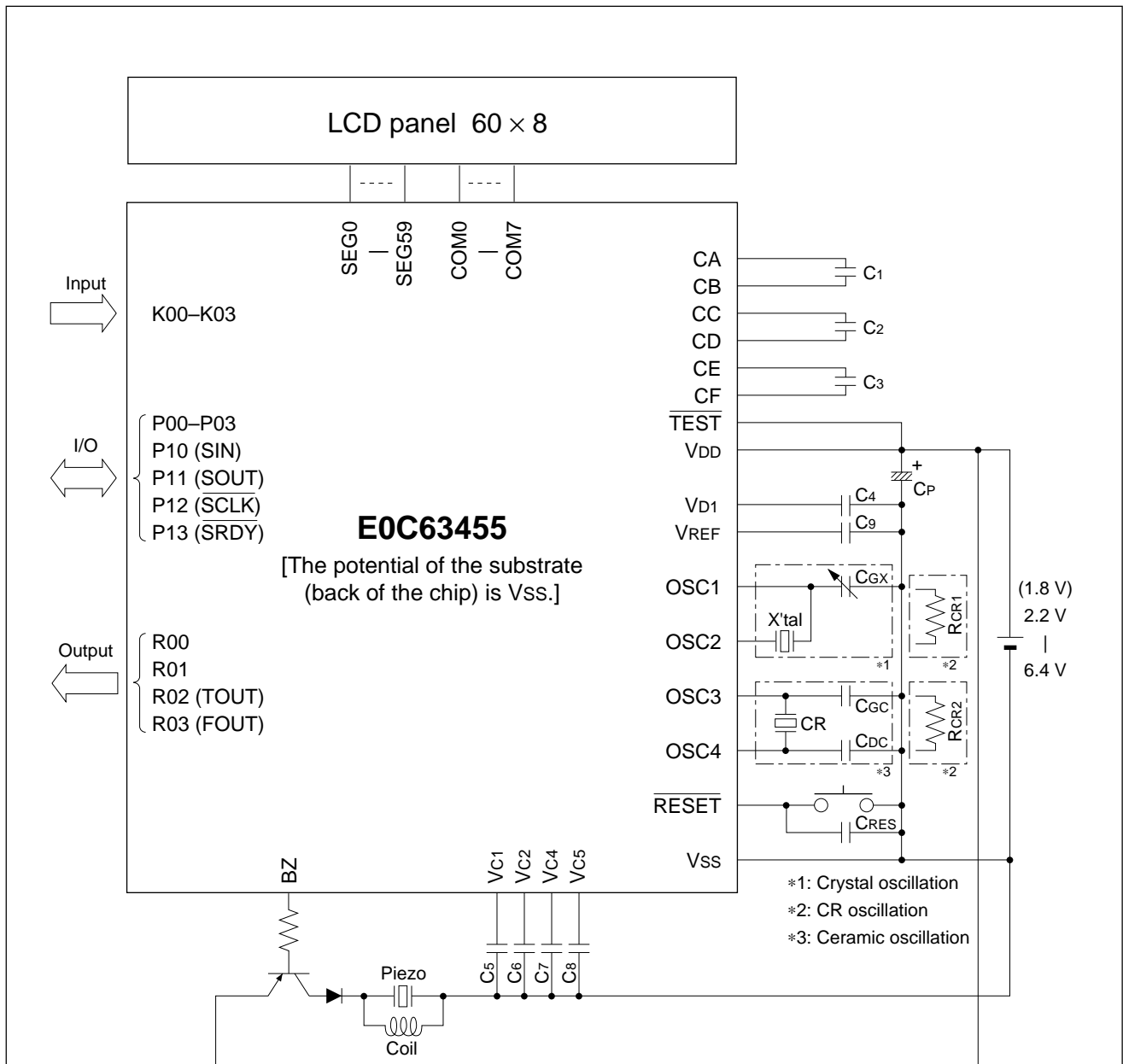

X'tal	Crystal oscillator	32.768 kHz, C ₁ (Max.) = 34 kΩ
CGX	Trimmer capacitor	5–25 pF
R _{CR1}	Resistor for OSC1 CR oscillation	520 kΩ (60 kHz)
CR	Ceramic oscillator	4 MHz (3.0 V)
CGC	Gate capacitor	30 pF
CDC	Drain capacitor	30 pF
R _{CR2}	Resistor for OSC3 CR oscillation	34 kΩ (1.8 MHz)
C ₁ –C ₈	Capacitor	0.2 μF
C ₉	Capacitor	0.1 μF
C _P	Capacitor	3.3 μF
C _{RES}	RESET terminal capacitor	0.1 μF

Note: The above table is simply an example, and is not guaranteed to work.

■ PAD LAYOUT

● Diagram of Pad Layout

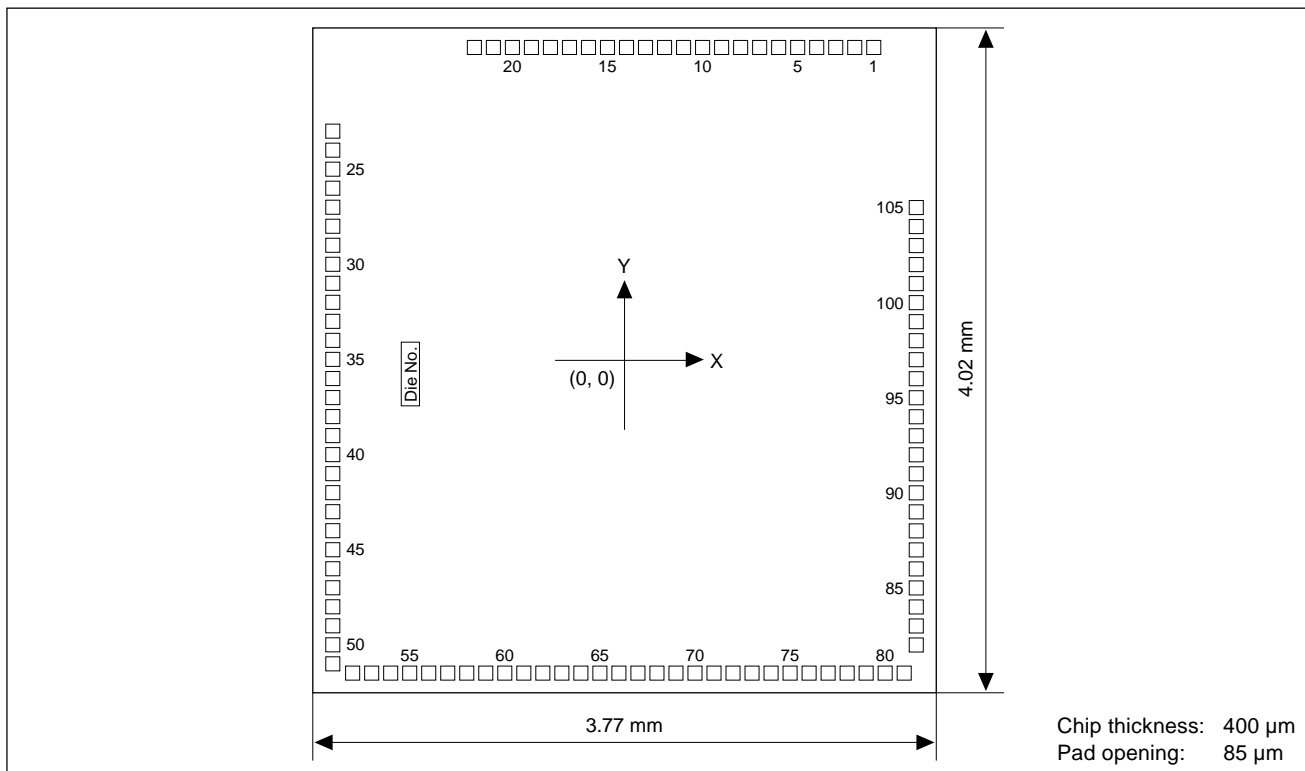

● Pad Coordinates

Unit: μm

No.	Pad name	X	Y	No.	Pad name	X	Y	No.	Pad name	X	Y	No.	Pad name	X	Y
1	OSC3	1,507	1,892	28	CE	-1,764	811	55	SEG37	-1,299	-1,891	82	SEG10	1,764	-1,721
2	OSC4	1,392	1,892	29	CD	-1,764	696	56	SEG36	-1,184	-1,891	83	SEG9	1,764	-1,606
3	V _{DD}	1,277	1,892	30	CC	-1,764	581	57	SEG35	-1,069	-1,891	84	SEG8	1,764	-1,491
4	RESET	1,162	1,892	31	CB	-1,764	466	58	SEG34	-954	-1,891	85	SEG7	1,764	-1,376
5	TEST	1,047	1,892	32	CA	-1,764	351	59	SEG33	-839	-1,891	86	SEG6	1,764	-1,261
6	V _{REF}	932	1,892	33	SEG59	-1,764	236	60	SEG32	-724	-1,891	87	SEG5	1,764	-1,146
7	R03	817	1,892	34	SEG58	-1,764	121	61	SEG31	-609	-1,891	88	SEG4	1,764	-1,031
8	R02	702	1,892	35	SEG57	-1,764	6	62	SEG30	-494	-1,891	89	SEG3	1,764	-916
9	R01	587	1,892	36	SEG56	-1,764	-110	63	SEG29	-379	-1,891	90	SEG2	1,764	-801
10	R00	472	1,892	37	SEG55	-1,764	-225	64	SEG28	-264	-1,891	91	SEG1	1,764	-686
11	P13	357	1,892	38	SEG54	-1,764	-340	65	SEG27	-149	-1,891	92	SEG0	1,764	-571
12	P12	242	1,892	39	SEG53	-1,764	-455	66	SEG26	-34	-1,891	93	COM7	1,764	-456
13	P11	127	1,892	40	SEG52	-1,764	-570	67	SEG25	81	-1,891	94	COM6	1,764	-341
14	P10	12	1,892	41	SEG51	-1,764	-685	68	SEG24	196	-1,891	95	COM5	1,764	-226
15	P03	-103	1,892	42	SEG50	-1,764	-800	69	SEG23	311	-1,891	96	COM4	1,764	-111
16	P02	-218	1,892	43	SEG49	-1,764	-915	70	SEG22	426	-1,891	97	COM3	1,764	4
17	P01	-333	1,892	44	SEG48	-1,764	-1,030	71	SEG21	541	-1,891	98	COM2	1,764	119
18	P00	-448	1,892	45	SEG47	-1,764	-1,145	72	SEG20	656	-1,891	99	COM1	1,764	234
19	K03	-563	1,892	46	SEG46	-1,764	-1,260	73	SEG19	771	-1,891	100	COM0	1,764	349
20	K02	-678	1,892	47	SEG45	-1,764	-1,375	74	SEG18	886	-1,891	101	BZ	1,764	464
21	K01	-793	1,892	48	SEG44	-1,764	-1,490	75	SEG17	1,001	-1,891	102	V _{SS}	1,764	579
22	K00	-908	1,892	49	SEG43	-1,764	-1,605	76	SEG16	1,116	-1,891	103	OSC1	1,764	694
23	V _{C1}	-1,764	1,386	50	SEG42	-1,764	-1,720	77	SEG15	1,231	-1,891	104	OSC2	1,764	809
24	V _{C2}	-1,764	1,271	51	SEG41	-1,764	-1,835	78	SEG14	1,346	-1,891	105	V _{D1}	1,764	924
25	V _{C4}	-1,764	1,156	52	SEG40	-1,644	-1,891	79	SEG13	1,461	-1,891				
26	V _{C5}	-1,764	1,041	53	SEG39	-1,529	-1,891	80	SEG12	1,576	-1,891				
27	CF	-1,764	926	54	SEG38	-1,414	-1,891	81	SEG11	1,691	-1,891				

E0C63455

■ PACKAGE DIMENSIONS

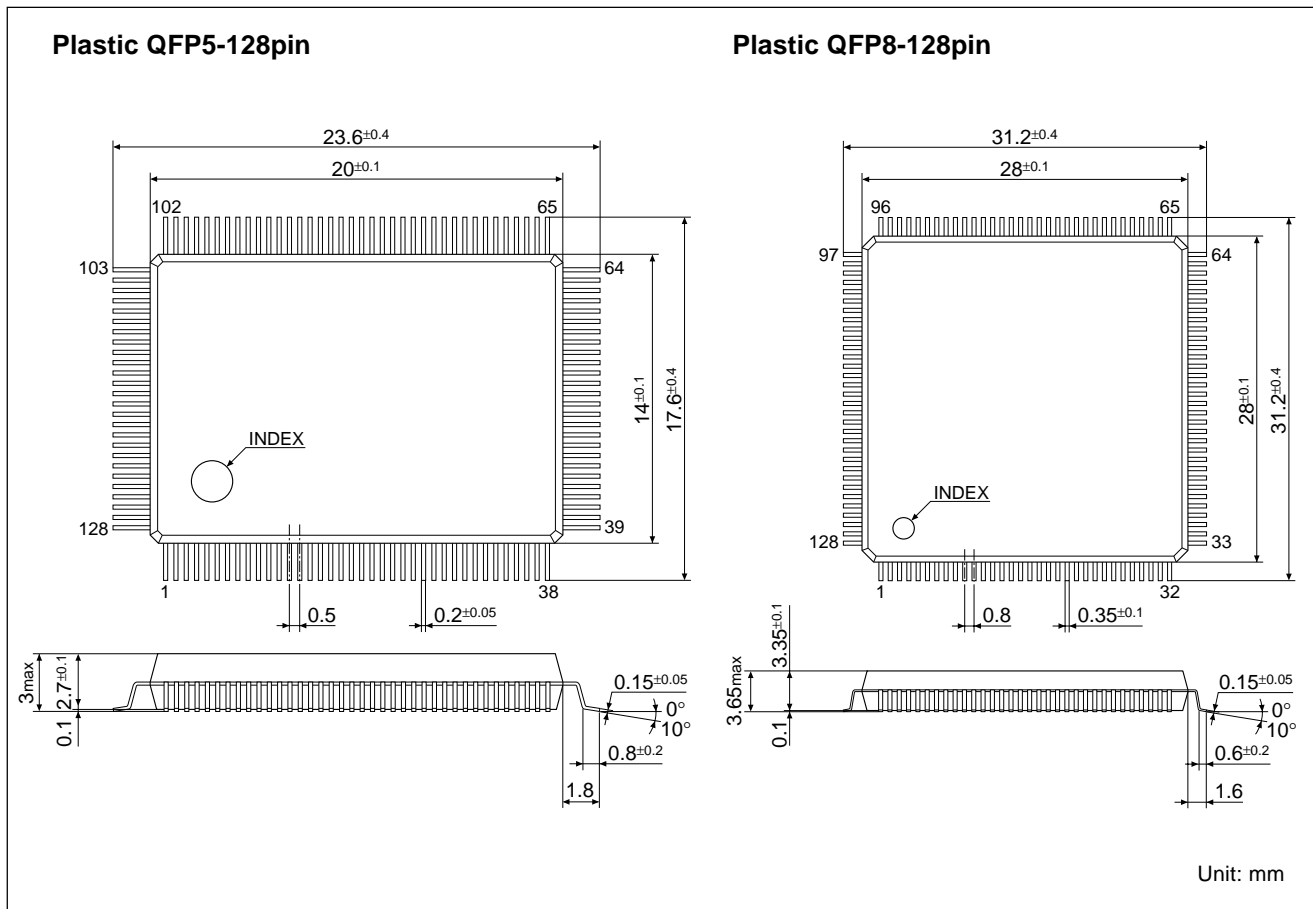

NOTICE:

No part of this material may be reproduced or duplicated in any form or by any means without the written permission of Seiko Epson. Seiko Epson reserves the right to make changes to this material without notice. Seiko Epson does not assume any liability of any kind arising out of any inaccuracies contained in this material or due to its application or use in any product or circuit and, further, there is no representation that this material is applicable to products requiring high level reliability, such as, medical products. Moreover, no license to any intellectual property rights is granted by implication or otherwise, and there is no representation or warranty that anything made in accordance with this material will be free from any patent or copyright infringement of a third party. This material or portions thereof may contain technology or the subject relating to strategic products under the control of the Foreign Exchange and Foreign Trade Law of Japan and may require an export license from the Ministry of International Trade and Industry or other approval from another government agency.

© Seiko Epson Corporation 2000 All right reserved.

SEIKO EPSON CORPORATION

ELECTRONIC DEVICES MARKETING DIVISION

IC Marketing & Engineering Group

ED International Marketing Department I (Europe & U.S.A.)

421-8, Hino, Hino-shi, Tokyo 191-8501, JAPAN
Phone : 042-587-5812 FAX : 042-587-5564

ED International Marketing Department II (Asia)

421-8, Hino, Hino-shi, Tokyo 191-8501, JAPAN
Phone : 042-587-5814 FAX : 042-587-5110

■ EPSON Electronic Devices Website

<http://www.epson.co.jp/device/>

