

8-bit Single Chip Microcomputer

Preliminary



- Original Architecture Core CPU
- Large Capacity ROM (116K bytes)
- Low Current Consumption
- Wide-range Operating Voltage (1.8V to 5.5V)
- Built-in Melody Generator and A/D Converter

■ DESCRIPTION

The E0C88816 is a CMOS 8-bit microcomputer composed of a CMOS 8-bit core CPU, ROM, RAM, I/O, serial interface, dot-matrix LCD driver, timer, event counter, melody generator and A/D converter. The E0C88816 fully operable over a wide range of voltages, and can perform high speed operations even at low voltage and low current consumption, it is suitable for portable systems that need to be driven with a battery.

■ FEATURES

- CMOS LSI 8-bit parallel processing
- OSC1 oscillation circuit 32.768kHz (Typ.) crystal/CR oscillation circuit
- OSC3 oscillation circuit 8.2MHz (Max.) crystal/ceramic/CR oscillation circuit
- Instruction set 608 types (usable for multiplication and division instructions)
- Instruction execution time 0.244 μsec/8.2MHz (for 2-clock instructions)
- ROM 116K bytes
- RAM 8K-byte RAM
4,224-bit display memory
512-byte melody RAM
- Input port 9 bits (1 bit can be set for event counter external clock input)
- Output port 7 bits (usable for buzzer, FOUT, TOUT signal outputs)
- I/O port 16 bits (usable for serial I/O and A/D inputs)
- Serial interface 1 ch. (8-bit clock synchronous or asynchronous system)
- Timer Programmable timer (8 bits) : 2 ch. (usable as a 1-ch. 16-bit timer)
Clock timer (8 bits) : 1 ch.
Stopwatch timer (8 bits) : 1 ch.
- LCD driver Dot-matrix type (supports 5 × 8 or 5 × 5 dot font)
72 segments × 32 commons, 88 segments × 16 or 8 commons
LCD power supply circuit built-in (boostor type, 5 potentials)
- Sound generator Envelope and volume control functions built-in
- Watchdog timer Built-in
- Supply voltage detection (SVD) circuit .. 16-level detection
- Melody generator 1 sound source (scale: 3 octaves, note: 8 types, tempo: 16 types)
Note and scale data are stored into the melody RAM
(allows the CPU to read and write)
- A/D converter 4 ch., 10-bit resolution, successive-approximation type
- Interrupt External : Input interrupt 2 systems (3 types)
Internal : Timer interrupt 3 systems (9 types)
: Serial I/F interrupt 1 system (3 types)
: Melody interrupt 1 system (1 type)
: A/D converter interrupt 1 system (1 type)

E0C8816

- Supply voltage Normal mode : 2.4V to 5.5V (Max. 4.2MHz)
 Low power mode : 1.8V to 3.5V (Max. 80kHz)
 High speed mode : 3.5V to 5.5V (Max. 8.2MHz)
- Current consumption SLEEP mode: 0.4μA (Typ., normal mode)
 HALT mode : 1.5μA (Typ., normal mode)
 Run (32kHz) : 7μA (Typ., normal mode)
 Run (4MHz) : 0.9mA (Typ., normal mode)
- Package QFP18-176pin (plastic) or chip

■ BLOCK DIAGRAM

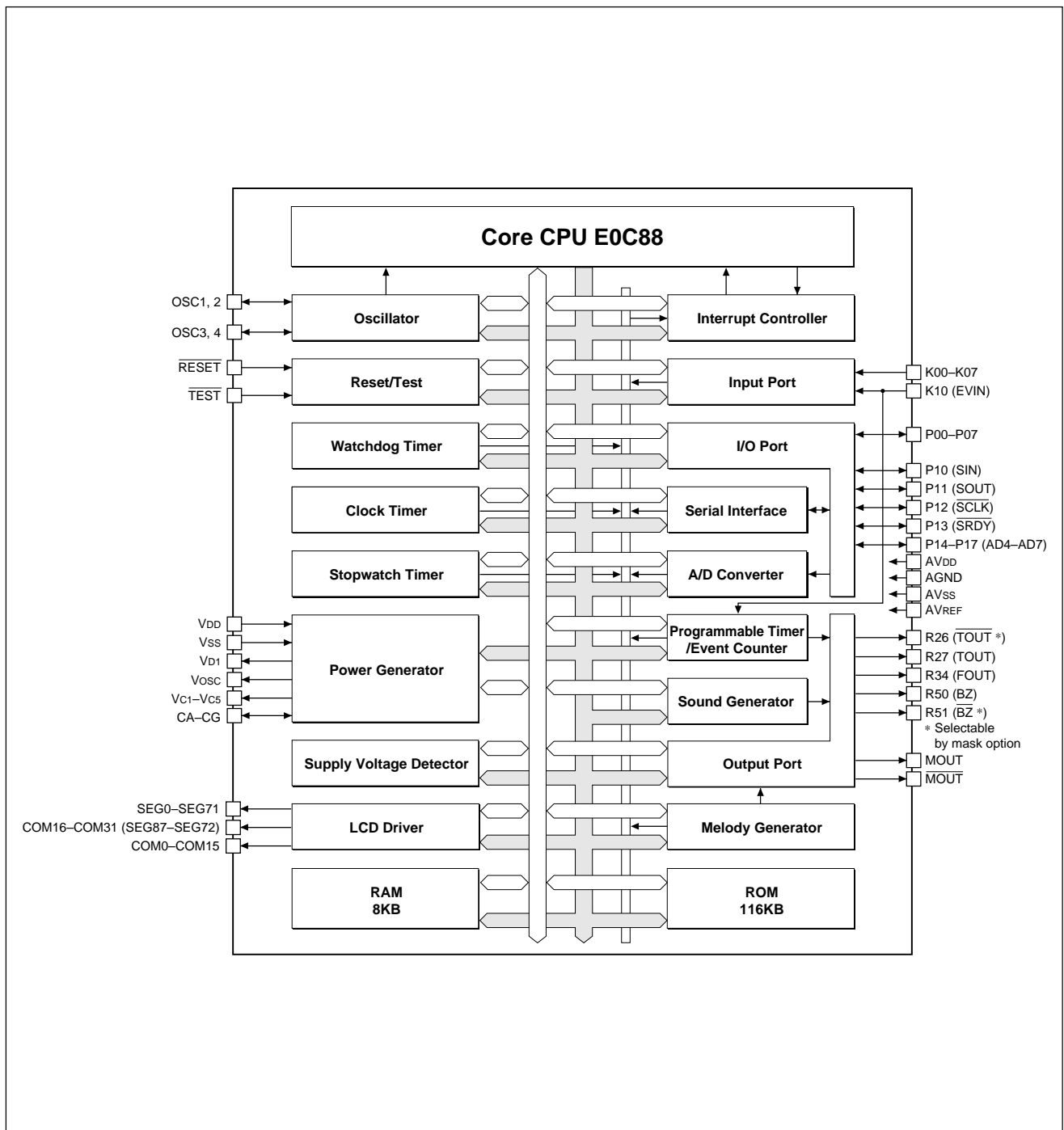

■ PIN CONFIGURATION

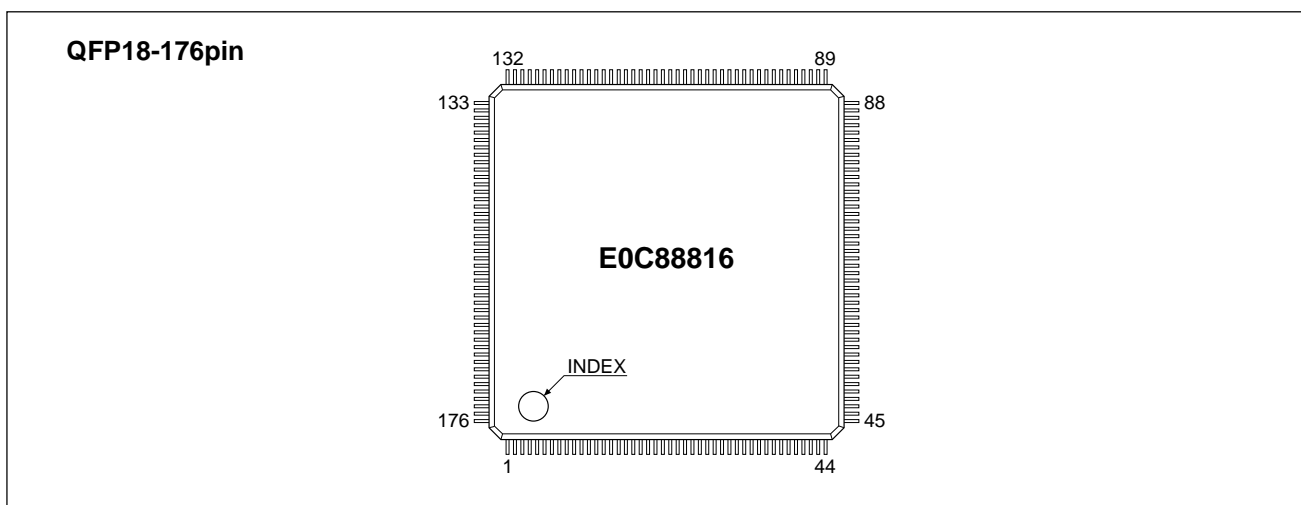

Pin No.	Pin name	Pin No.	Pin name	Pin No.	Pin name	Pin No.	Pin name
1	N.C.	45	N.C.	89	N.C.	133	N.C.
2	N.C.	46	SEG56	90	N.C.	134	N.C.
3	SEG16	47	SEG57	91	Vc3	135	P01
4	SEG17	48	SEG58	92	Vc2	136	P00
5	SEG18	49	SEG59	93	Vc1	137	MOUT
6	SEG19	50	SEG60	94	OSC3	138	MOUT
7	SEG20	51	SEG61	95	OSC4	139	R26/TOUT
8	SEG21	52	SEG62	96	Vd1	140	R27/TOUT
9	SEG22	53	SEG63	97	VDD	141	R34/FOUT
10	SEG23	54	SEG64	98	Vss	142	R50/BZ
11	SEG24	55	SEG65	99	Vosc	143	R51/BZ
12	SEG25	56	SEG66	100	OSC1	144	COM0
13	SEG26	57	SEG67	101	OSC2	145	COM1
14	SEG27	58	SEG68	102	TEST	146	COM2
15	SEG28	59	SEG69	103	RESET	147	COM3
16	SEG29	60	SEG70	104	K10/EVIN	148	COM4
17	SEG30	61	SEG71	105	K07	149	COM5
18	SEG31	62	COM31/SEG72	106	K06	150	COM6
19	SEG32	63	COM30/SEG73	107	K05	151	COM7
20	SEG33	64	COM29/SEG74	108	K04	152	COM8
21	SEG34	65	COM28/SEG75	109	K03	153	COM9
22	SEG35	66	COM27/SEG76	110	K02	154	COM10
23	SEG36	67	COM26/SEG77	111	K01	155	COM11
24	SEG37	68	COM25/SEG78	112	K00	156	COM12
25	SEG38	69	COM24/SEG79	113	P17/AD7	157	COM13
26	SEG39	70	COM23/SEG80	114	P16/AD6	158	COM14
27	SEG40	71	COM22/SEG81	115	P15/AD5	159	COM15
28	SEG41	72	COM21/SEG82	116	P14/AD4	160	SEG0
29	SEG42	73	COM20/SEG83	117	P13/SRDY	161	SEG1
30	SEG43	74	COM19/SEG84	118	P12/SCLK	162	SEG2
31	SEG44	75	COM18/SEG85	119	P11/SOUT	163	SEG3
32	SEG45	76	COM17/SEG86	120	P10/SIN	164	SEG4
33	SEG46	77	COM16/SEG87	121	AVDD	165	SEG5
34	SEG47	78	CG	122	AGND	166	SEG6
35	SEG48	79	CF	123	AVss	167	SEG7
36	SEG49	80	CE	124	AVREF	168	SEG8
37	SEG50	81	CD	125	P07	169	SEG9
38	SEG51	82	CC	126	P06	170	SEG10
39	SEG52	83	CB	127	P05	171	SEG11
40	SEG53	84	CA	128	P04	172	SEG12
41	SEG54	85	Vc5	129	P03	173	SEG13
42	SEG55	86	Vc4	130	P02	174	SEG14
43	N.C.	87	N.C.	131	N.C.	175	SEG15
44	N.C.	88	N.C.	132	N.C.	176	N.C.

N.C.: No Connection

■ PIN DESCRIPTION

Pin name	Pin No.	In/Out	Function
V _{DD}	97	–	Power supply (+) terminal
V _{SS}	98	–	Power supply (GND) terminal
V _{b1}	96	–	Regulated voltage for internal circuit
V _{osc}	99	–	Regulated voltage for OSC1 oscillation circuit
V _{C1} –V _{C5}	93–91, 86, 85	O	LCD drive voltage output terminals
CA–CG	84–78	–	Voltage boost/reduce-capacitor connection terminals for LCD
OSC1	100	I	OSC1 oscillation input terminal (select crystal oscillation/CR oscillation/external clock input by mask option)
OSC2	101	O	OSC1 oscillation output terminal
OSC3	94	I	OSC3 oscillation input terminal (select crystal/ceramic/CR oscillation/external clock input by mask option)
OSC4	95	O	OSC3 oscillation output terminal
K00–K07	112–105	I	Input terminals (K00–K07)
K10/EVIN	104	I	Input terminal (K10) or event counter external clock input terminal (EVIN)
R26/TOUT	139	O	Output terminal (R26) or programmable timer underflow signal inverted output terminal (TOUT) (selectable by mask option)
R27/TOUT	140	O	Output terminal (R27) or programmable timer underflow signal output terminal (TOUT)
R34/FOUT	141	O	Output terminal (R34) or clock output terminal (FOUT)
R50/BZ	142	O	Output terminal (R50) or buzzer output terminal (BZ)
R51/BZ	143	O	Output terminal (R51) or buzzer inverted output terminal (BZ) (selectable by mask option)
P00–P07	136, 135, 130–125	I/O	I/O terminals (P00–P07)
P10/SIN	120	I/O	I/O terminal (P10) or serial I/F data input terminal (SIN)
P11/SOUT	119	I/O	I/O terminal (P11) or serial I/F data output terminal (SOUT)
P12/SCLK	118	I/O	I/O terminal (P12) or serial I/F clock I/O terminal (SCLK)
P13/SRDY	117	I/O	I/O terminal (P13) or serial I/F ready signal output terminal (SRDY)
P14/AD4	116	I/O	I/O terminal (P14) or A/D converter input terminal (AD4)
P15/AD5	115	I/O	I/O terminal (P15) or A/D converter input terminal (AD5)
P16/AD6	114	I/O	I/O terminal (P16) or A/D converter input terminal (AD6)
P17/AD7	113	I/O	I/O terminal (P17) or A/D converter input terminal (AD7)
MOUT	137	O	Melody output terminal
MOUT	138	O	Melody inverted output terminal
COM0–COM15	144–159	O	LCD common output terminals
COM16–COM31 /SEG87–SEG72	77–62	O	LCD common output terminals (when 1/32 duty is selected) or LCD segment output terminal (when 1/16 or 1/8 duty is selected)
SEG0–SEG71	160–175, 3–42, 46–61	O	LCD segment output terminals
RESET	103	I	Initial reset input terminal
TEST *1	102	I	Test input terminal
AV _{DD}	121	–	Analog system power supply (+) terminal
AV _{SS}	123	–	Analog system power supply (–) terminal
AGND	122	–	Analog system ground terminal
AVREF	124	I	Analog system reference voltage input terminal

*1 TEST is the terminal used for shipping inspection of the IC. For normal operation be sure it is connected to V_{DD}.

■ MASK OPTION

1 OSC1 SYSTEM CLOCK

- 1. Crystal
- 2. External Clock
- 3. CR
- 4. Crystal (with Gate Capacity)

The specification of the OSC1 oscillation circuit can be selected from among four types: "Crystal oscillation", "CR oscillation", "Crystal oscillation (gate capacitor built-in)" and "External clock input".

2 OSC3 SYSTEM CLOCK

- 1. Crystal
- 2. Ceramic
- 3. CR
- 4. External Clock

The specification of the OSC3 oscillation circuit can be selected from among four types: "Crystal oscillation", "Ceramic oscillation", "CR oscillation" and "External clock input".

3 MULTIPLE KEY ENTRY RESET

- Combination 1. Not Use
- 2. Use K00, K01
- 3. Use K00, K01, K02
- 4. Use K00, K01, K02, K03

Selects whether the reset function when several keys are pressed simultaneously is used or not. Further when the function is used, a combination of the input ports (K00–K03), which are connected to the keys to be pressed simultaneously, can be selected.

4 SVD RESET

- 1. Not Use
- 2. Use

Selects whether the SVD reset function when the supply voltage drops is used or not.

5 INPUT PORT PULL UP RESISTOR

- | | | |
|----------------------|---|---|
| • K00 | <input type="checkbox"/> 1. With Resistor | <input type="checkbox"/> 2. Gate Direct |
| • K01 | <input type="checkbox"/> 1. With Resistor | <input type="checkbox"/> 2. Gate Direct |
| • K02 | <input type="checkbox"/> 1. With Resistor | <input type="checkbox"/> 2. Gate Direct |
| • K03 | <input type="checkbox"/> 1. With Resistor | <input type="checkbox"/> 2. Gate Direct |
| • K04 | <input type="checkbox"/> 1. With Resistor | <input type="checkbox"/> 2. Gate Direct |
| • K05 | <input type="checkbox"/> 1. With Resistor | <input type="checkbox"/> 2. Gate Direct |
| • K06 | <input type="checkbox"/> 1. With Resistor | <input type="checkbox"/> 2. Gate Direct |
| • K07 | <input type="checkbox"/> 1. With Resistor | <input type="checkbox"/> 2. Gate Direct |
| • K10 | <input type="checkbox"/> 1. With Resistor | <input type="checkbox"/> 2. Gate Direct |
| • <u>RESET</u> | <input type="checkbox"/> 1. With Resistor | <input type="checkbox"/> 2. Gate Direct |

Selects whether the pull-up resistor for the input port terminal is used or not. It is possible to select for each bit of the input ports.

Furthermore, pull-up option is also provided for the RESET terminal.

6 I/O PORT PULL UP RESISTOR

- | | | |
|-------------|---|---|
| • P00 | <input type="checkbox"/> 1. With Resistor | <input type="checkbox"/> 2. Gate Direct |
| • P01 | <input type="checkbox"/> 1. With Resistor | <input type="checkbox"/> 2. Gate Direct |
| • P02 | <input type="checkbox"/> 1. With Resistor | <input type="checkbox"/> 2. Gate Direct |
| • P03 | <input type="checkbox"/> 1. With Resistor | <input type="checkbox"/> 2. Gate Direct |
| • P04 | <input type="checkbox"/> 1. With Resistor | <input type="checkbox"/> 2. Gate Direct |
| • P05 | <input type="checkbox"/> 1. With Resistor | <input type="checkbox"/> 2. Gate Direct |
| • P06 | <input type="checkbox"/> 1. With Resistor | <input type="checkbox"/> 2. Gate Direct |
| • P07 | <input type="checkbox"/> 1. With Resistor | <input type="checkbox"/> 2. Gate Direct |
| • P10 | <input type="checkbox"/> 1. With Resistor | <input type="checkbox"/> 2. Gate Direct |
| • P11 | <input type="checkbox"/> 1. With Resistor | <input type="checkbox"/> 2. Gate Direct |
| • P12 | <input type="checkbox"/> 1. With Resistor | <input type="checkbox"/> 2. Gate Direct |
| • P13 | <input type="checkbox"/> 1. With Resistor | <input type="checkbox"/> 2. Gate Direct |
| • P14 | <input type="checkbox"/> 1. With Resistor | <input type="checkbox"/> 2. Gate Direct |
| • P15 | <input type="checkbox"/> 1. With Resistor | <input type="checkbox"/> 2. Gate Direct |
| • P16 | <input type="checkbox"/> 1. With Resistor | <input type="checkbox"/> 2. Gate Direct |
| • P17 | <input type="checkbox"/> 1. With Resistor | <input type="checkbox"/> 2. Gate Direct |

Selects whether the pull-up resistor for the I/O port terminal (it works during input mode) is used or not. It is possible to select for each bit of the I/O ports.

Since P10 to P13 are shared with the serial interface I/O terminals, the selected P10 and P12 terminal configuration is applied to the serial input (SIN) terminal and serial clock input terminal (SCLK in clock synchronous mode) when the serial interface is used.

<p>7 LCD DRIVE DUTY</p> <ul style="list-style-type: none"> <input type="checkbox"/> 1. 1/32 & 1/16 Duty <input type="checkbox"/> 2. 1/8 Duty 	<p>The drive duty for the built-in LCD driver can be selected whether it will be 1/32 and 1/16 software-switched or fixed at 1/8.</p>
<p>8 LCD POWER SUPPLY</p> <ul style="list-style-type: none"> <input type="checkbox"/> 1. Internal TYPE A (Vc2 Standard, 1/5 Bias, 4.5 V) <input type="checkbox"/> 2. External <input type="checkbox"/> 3. Internal TYPE B (Vc2 Standard, 1/5 Bias, 5.5 V) <input type="checkbox"/> 4. Internal TYPE C (Vc2 Standard, 1/4 Bias, 4.5 V) <input type="checkbox"/> 5. Internal TYPE D (Vc1 Standard, 1/4 Bias, 4.5 V) 	<p>Either the internal power supply or an external power supply can be selected as the LCD system power source. Furthermore, when using the internal power supply, the LCD drive voltage can be set for a 4.5 V panel or a 5.5 V panel and the drive bias to 1/5 or 1/4.</p>
<p>9 $\overline{\text{BZ}}$ OUTPUT (R51)</p> <ul style="list-style-type: none"> <input type="checkbox"/> 1. Use <input type="checkbox"/> 2. Not Use 	<p>The R51 port can be configured as a general purpose output port or as the $\overline{\text{BZ}}$ output port (BZ inverted output).</p>
<p>10 $\overline{\text{TOUT}}$ OUTPUT (R26)</p> <ul style="list-style-type: none"> <input type="checkbox"/> 1. Use <input type="checkbox"/> 2. Not Use 	<p>The R26 port can be configured as a general purpose output port or as the $\overline{\text{TOUT}}$ output port (TOUT inverted output).</p>
<p>11 CPU MODE</p> <ul style="list-style-type: none"> <input type="checkbox"/> 1. Maximum Mode <input type="checkbox"/> 2. Minimum Mode 	<p>The CPU mode of the E0C88 core can be selected from between maximum mode and minimum mode (fixed after selection).</p>
<p>12 MODE DURING BUZZER OUTPUT</p> <ul style="list-style-type: none"> <input type="checkbox"/> 1. Normal Mode <input type="checkbox"/> 2. Heavy Load Protection Mode 	<p>This option allows selection whether the heavy load protection mode is set or not when the buzzer (BZ) signal is output.</p>
<p>13 MODE DURING MELODY OUTPUT</p> <ul style="list-style-type: none"> <input type="checkbox"/> 1. Normal Mode <input type="checkbox"/> 2. Heavy Load Protection Mode 	<p>This option allows selection whether the heavy load protection mode is set or not when the melody (MOUT) signal is output.</p>

■ ELECTRICAL CHARACTERISTICS

● Absolute Maximum Ratings

(Vss=0V)

Item	Symbol	Condition	Rated value	Unit	Note
Power voltage	V _{DD}		-0.3 to +7.0	V	
Liquid crystal power voltage	V _{C5}		-0.3 to +7.0	V	
Input voltage	V _I		-0.3 to V _{DD} + 0.3	V	
Output voltage	V _O		-0.3 to V _{DD} + 0.3	V	1
High level output current	I _{OH}	1 terminal	-5	mA	
		Total of all terminals	-20	mA	
Low level output current	I _{OL}	1 terminal	5	mA	
		Total of all terminals	20	mA	
Permitted loss	P _D		200	mW	2
Operating temperature	T _{opr}		-40 to +85	°C	
Storage temperature	T _{stg}		-65 to +150	°C	
Soldering temperature / time	T _{sol}		260°C, 10sec (lead section)	—	

Note) 1 Case that to Nch open drain output by the mask option is included.

2 In case of plastic package.

● Recommended Operating Conditions

(V_{SS}=0V, T_a=-40 to 85°C)

Item	Symbol	Condition	Min.	Typ.	Max.	Unit	Note
Operating power voltage (Normal mode)	V _{DD}		2.4		5.5	V	
Operating power voltage (Low power mode)	V _{DD}		1.8		5.5	V	
Operating power voltage (High speed mode)	V _{DD}		3.5		5.5	V	
Analog power voltage	AV _{DD}	AV _{DD} ≥ 2.7 V	V _{DD} -0.05		V _{DD} +0.05	V	
Operating frequency (Normal mode)	f _{OSC1}	V _{DD} = 2.4 to 5.5 V	30.000	32.768	80.000	kHz	1
	f _{OSC3}		0.03		4.2	MHz	1
Operating frequency (Low power mode)	f _{OSC1}	V _{DD} = 1.8 to 3.5 V	30.000	32.768	80.000	kHz	1
Operating frequency (High speed mode)	f _{OSC1}	V _{DD} = 3.5 to 5.5 V	30.000	32.768	80.000	kHz	1
	f _{OSC3}		0.03		8.2	MHz	1
Liquid crystal power voltage	V _{C5}	V _{C5} ≥ V _{C4} ≥ V _{C3} ≥ V _{C2} ≥ V _{C1} ≥ V _{SS}			6.0	V	2
Capacitor between V _{D1} and V _{SS}	C ₁			0.1		μF	
Capacitor between V _{C1} and V _{SS}	C ₂			0.1		μF	3
Capacitor between V _{C2} and V _{SS}	C ₃			0.1		μF	3
Capacitor between V _{C3} and V _{SS}	C ₄			0.1		μF	3
Capacitor between V _{C4} and V _{SS}	C ₅			0.1		μF	3
Capacitor between V _{C5} and V _{SS}	C ₆			0.1		μF	3
Capacitor between CA and CB	C ₇			0.1		μF	3
Capacitor between CA and CC	C ₈			0.1		μF	3
Capacitor between CD and CE	C ₉			0.1		μF	3
Capacitor between CF and CG	C ₁₀			0.1		μF	3

- Note) 1 When an external clock is input from the OSC1 terminal by the mask option, leave the OSC2 terminal open, and when an external clock is input from the OSC3 terminal, leave the OSC4 terminal open.
 2 When external power supply is selected by the mask option.
 3 When LCD drive power is not used, the capacitor is not necessary. In this case, leave the V_{C1} to V_{C5} and CA to CG terminals open.

● DC Characteristics

(Unless otherwise specified: V_{DD}=1.8 to 5.5V, V_{SS}=0V, T_a=-40 to 85°C)

Item	Symbol	Condition	Min.	Typ.	Max.	Unit	Note
High level input voltage (1)	V _{IH1}	Kxx, Pxx	0.8V _{DD}		V _{DD}	V	
Low level input voltage (1)	V _{IL1}	Kxx, Pxx	0		0.2V _{DD}	V	
High level input voltage (2) (Normal mode)	V _{IH2}	OSC3	1.6		V _{DD}	V	1
High level input voltage (2)	V _{IH2}	OSC1	1.0		V _{DD}	V	1
High level input voltage (2) (High speed mode)	V _{IH2}	OSC3	2.4		V _{DD}	V	1
Low level input voltage (2) (Normal mode)	V _{IL2}	OSC3	0		0.6	V	1
Low level input voltage (2)	V _{IL2}	OSC1	0		0.3	V	1
Low level input voltage (2) (High speed mode)	V _{IL2}	OSC3	0		0.9	V	1
High level schmitt input voltage	V _{T+}	RESET	0.5V _{DD}		0.9V _{DD}	V	
Low level schmitt input voltage	V _{T-}	RESET	0.1V _{DD}		0.5V _{DD}	V	
High level output current	I _{OH}	Pxx, Rxx, V _{OH} = 0.9V _{DD}			-0.5	mA	
Low level output current	I _{OL}	Pxx, Rxx, V _{OL} = 0.1V _{DD}	0.5			mA	
Input leak current	I _{LI}	Kxx, Pxx, RESET	-1		1	μA	
Output leak current	I _{LO}	Pxx, Rxx	-1		1	μA	
Input pull-up resistance	R _{IN}	Kxx, Pxx, RESET	100	300	500	kΩ	2
Input terminal capacitance	C _{IN}	Kxx, Pxx, V _{IN} = 0V, f = 1MHz, T _a = 25°C		7	15	pF	
Segment/Common output current	I _{SEGH}	SEGxx, COMxx, V _{SEGH} = V _{C5} -0.1V			-5	μA	
	I _{SEGL}	SEGxx, COMxx, V _{SEGL} = 0.1V	5			μA	

- Note) 1 When external clock is selected by mask option.
 2 When pull-up resistor is added by mask option.

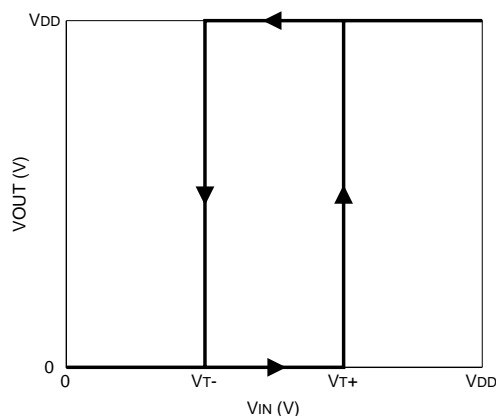

E0C88816

● LCD Driver

The Typ. values of the LCD drive voltage shown in the following table shift in difference of panel load (panel size, drive duty, display segment number). Therefore, these should be evaluated by connecting to the actual panel to be used.

(Unless otherwise specified: $V_{DD}=V_{C2} (LCX= FH) + 0.1$ to 5.5V, $V_{SS}=0V$, $T_a=25^{\circ}C$, $C_1-C_{10}=0.1\mu F$)

Item	Symbol	Condition	Min.	Typ.	Max.	Unit	Note	
LCD drive voltage (Vc2 standard)	Vc2	When 1 MΩ load resistor is connected between Vss and Vc2 (no panel load)	0.412Vc5			V		
	Vc5 TYPE A (4.5V)	When 1 MΩ load resistor is connected between Vss and Vc5 (no panel load)	LCX = 0H	Typ×0.94	3.52	Typ×1.06	V	1
			LCX = 1H		3.64			
			LCX = 2H		3.76			
			LCX = 3H		3.88			
			LCX = 4H		4.00			
			LCX = 5H		4.12			
			LCX = 6H		4.24			
			LCX = 7H		4.37			
			LCX = 8H		4.51			
			LCX = 9H		4.63			
			LCX = AH		4.75			
			LCX = BH		4.87			
			LCX = CH		5.00			
			LCX = DH		5.12			
			LCX = EH		5.24			
			LCX = FH		5.36			
	Vc5 TYPE B (5.5V)	When 1 MΩ load resistor is connected between Vss and Vc5 (no panel load)	LCX = 0H	Typ×0.94	4.20	Typ×1.06	V	1
			LCX = 1H		4.34			
			LCX = 2H		4.49			
			LCX = 3H		4.63			
			LCX = 4H		4.78			
			LCX = 5H		4.92			
			LCX = 6H		5.07			
			LCX = 7H		5.21			
			LCX = 8H		5.36			
			LCX = 9H		5.50			
LCX = AH			5.65					
LCX = BH			5.80					
LCX = CH			5.94					
LCX = DH			6.09					
LCX = EH			6.23					
LCX = FH			6.38					
LCD drive voltage (Vc1 standard)	Vc1	When 1 MΩ load resistor is connected between Vss and Vc1 (no panel load)	0.260Vc5			V		
	Vc5 TYPE A (4.5V)	When 1 MΩ load resistor is connected between Vss and Vc5 (no panel load)	LCX = 0H	Typ×0.94	3.80	Typ×1.06	V	1
LCX = 1H			3.88					
LCX = 2H			3.96					
LCX = 3H			4.03					
LCX = 4H			4.15					
LCX = 5H			4.22					
LCX = 6H			4.30					
LCX = 7H			4.38					
LCX = 8H			4.45					
LCX = 9H			4.53					
LCX = AH			4.65					
LCX = BH			4.72					
LCX = CH			4.80					
LCX = DH			4.88					
LCX = EH			4.95					
LCX = FH			5.07					

Note) 1 Fixing the LCD contrast is not recommended. A contrast adjustment function should be included in the software.

● SVD Circuit

(Unless otherwise specified: $V_{DD}=1.8$ to $5.5V$, $V_{SS}=0V$, $T_a=25^\circ C$)

Item	Symbol	Condition	Min.	Typ.	Max.	Unit	Note		
SVD voltage	VSVD	Level 1 → Level 0	Typ×0.92	1.82	Typ×1.08	V	1		
		Level 2 → Level 1		2.00		V	1		
		Level 3 → Level 2		2.18		V	1		
		Level 4 → Level 3		2.36		V	2		
		Level 5 → Level 4		2.54		V	2		
		Level 6 → Level 5		2.72		V	2		
		Level 7 → Level 6		2.90		V	3		
		Level 8 → Level 7		3.08		V	3		
		Level 9 → Level 8		3.26		V	3		
		Level 10 → Level 9		3.45		V	4		
		Level 11 → Level 10		3.65		V	4		
		Level 12 → Level 11		3.85		V	4		
		Level 13 → Level 12		Typ×0.88		4.00	Typ×1.12	V	4
		Level 14 → Level 13		4.15		V	4		
		Level 15 → Level 14		4.35		V	4		

$VSVD$ (Level 0) < $VSVD$ (Level 1) < $VSVD$ (Level 2) < $VSVD$ (Level 3) < $VSVD$ (Level 4) < $VSVD$ (Level 5) < $VSVD$ (Level 6) < $VSVD$ (Level 7) < $VSVD$ (Level 8) < $VSVD$ (Level 9) < $VSVD$ (Level 10) < $VSVD$ (Level 11) < $VSVD$ (Level 12) < $VSVD$ (Level 13) < $VSVD$ (Level 14) < $VSVD$ (Level 15)

- Note) 1 Low power operating mode only
 2 Low power operating mode or Normal operating mode only
 3 Normal operating mode only
 4 Normal operating mode or High speed operating mode only

● Current Consumption

(Unless otherwise specified: V_{DD} =Within the operating voltage in each operating mode, $V_{SS}=0V$, $T_a=25^\circ C$, $OSC1=32.768kHz$ crystal oscillation, $C_G=25pF$, $OSC3$ =crystal/ceramic oscillation, Non heavy load protection mode, $C_1-C_{10}=0.1\mu F$, No panel load)

Item	Symbol	Condition	Min.	Typ.	Max.	Unit	Note
Power current (Normal mode)	IDD1	In SLEEP status *1		0.45	1.6	μA	
	IDD2	In HALT status *2		1.5	3.5	μA	
	IDD3	CPU is in operating (32.768 kHz) *3		7	10	μA	
	IDD4	CPU is in operating (4 MHz) *4		0.9	1.1	mA	
Power current (Low power mode)	IDD1	In SLEEP status *1		0.30	1	μA	
	IDD2	In HALT status *2		1	2.5	μA	
	IDD3	CPU is in operating (32.768 kHz) *3		5	7	μA	
Power current (High speed mode)	IDD1	In SLEEP status *1		1	3	μA	
	IDD2	In HALT status *2		2	5	μA	
	IDD3	CPU is in operating (32.768 kHz) *3		12	16	μA	
	IDD4	CPU is in operating (8 MHz) *5		3.3	3.9	mA	
LCD drive circuit current	ILCDN			5	6	μA	1
	ILCDH	In heavy load protection mode		33	40	μA	2
SVD circuit current	ISVDN	$V_{DD} = 3.0 V$		27	40	μA	3
OSC1 CR oscillation current ($R_{CR1} = 500 k\Omega$)	ICR1	In HALT status (50 kHz)		10	15	μA	4

- *1 OSC1: Stop, OSC3 = Stop, CPU, ROM, RAM: SLEEP status, Clock timer: Stop, Others: Stop status
 *2 OSC1: Oscillating, OSC3 = Stop, CPU, ROM, RAM: HALT status, Clock timer: Operating, Others: Stop status
 *3 OSC1: Oscillating, OSC3 = Stop, CPU, ROM, RAM: Operating in 32.768 kHz, Clock timer: Operating, Others: Stop status
 *4 OSC1: Oscillating, OSC3 = Oscillating, CPU, ROM, RAM: Operating in 4 MHz, Clock timer: Operating, Others: Stop status
 *5 OSC1: Oscillating, OSC3 = Oscillating, CPU, ROM, RAM: Operating in 8 MHz, Clock timer: Operating, Others: Stop status

- Note) 1 The LCD drive circuit current varies according to the display patterns.
 2 Heavy load protection circuit current in heavy load protection mode
 When the OSC3 oscillation circuit is turned ON, the IC always enters heavy load protection mode.
 The mode while the buzzer or melody signals are being output can be selected by mask option.
 When using a bipolar transistor as the example of the R50 terminal shown in "■ BASIC EXTERNAL CONNECTION DIAGRAM", select heavy load protection mode. When direct driving a piezoelectric buzzer as the example of the MOUT and /MOUT terminals, select normal mode.
 3 The value in $x V$ can be found by the following expression: $ISVDN (V_{DD} = x V) = (x \times 20) - 30$ (Typ. value),
 $ISVDN (V_{DD} = x V) = (x \times 30) - 30$ (Max. value)
 4 When OSC1 CR oscillation circuit is selected by the mask option.

E0C88816

● AC Characteristics

External memory access

(Condition: V_{DD} =Within the operating voltage in each operating mode, $V_{SS}=0$ V, $T_a=-40$ to 85°C)

Item	Item	Condition	Min.	Typ.	Max.	Unit	Note
Operating frequency (Normal mode)	fosc1	$V_{DD} = 2.4$ to 5.5 V	30.000	32.768	80.000	kHz	
	fosc3		0.03		4.2		
Operating frequency (Low power mode)	fosc1	$V_{DD} = 1.8$ to 3.5 V	30.000	32.768	80.000	kHz	
Operating frequency (High speed mode)	fosc1	$V_{DD} = 3.5$ to 5.5 V	30.000	32.768	80.000	kHz	
	fosc3		0.03		8.2		
Instruction execution time (during operation with OSC1 clock)	tcy	1-cycle instruction	25	61	67	μS	
		2-cycle instruction	50	122	133	μS	
		3-cycle instruction	75	183	200	μS	
		4-cycle instruction	100	244	267	μS	
		5-cycle instruction	125	305	333	μS	
		6-cycle instruction	150	366	400	μS	
Instruction execution time Normal mode (during operation with OSC3 clock)	tcy	1-cycle instruction	0.5		66.7	μS	
		2-cycle instruction	1.0		133.3	μS	
		3-cycle instruction	1.4		200.0	μS	
		4-cycle instruction	1.9		266.7	μS	
		5-cycle instruction	2.4		333.3	μS	
		6-cycle instruction	2.9		400.0	μS	
Instruction execution time High speed mode (during operation with OSC3 clock)	tcy	1-cycle instruction	0.2		66.7	μS	
		2-cycle instruction	0.5		133.3	μS	
		3-cycle instruction	0.7		200.0	μS	
		4-cycle instruction	1.0		266.7	μS	
		5-cycle instruction	1.2		333.3	μS	
		6-cycle instruction	1.5		400.0	μS	

Serial interface

• Clock synchronous master mode (Normal operating mode)

(Condition: $V_{DD}=2.4$ to 5.5 V, $V_{SS}=0$ V, $T_a=-40$ to 85°C , $V_{IH1}=0.8V_{DD}$, $V_{IL1}=0.2V_{DD}$, $V_{OH}=0.8V_{DD}$, $V_{OL}=0.2V_{DD}$)

Item	Symbol	Min.	Typ.	Max.	Unit	Note
Transmitting data output delay time	t _{sm} d			200	nS	
Receiving data input set-up time	t _{sm} s	500			nS	
Receiving data input hold time	t _{sm} h	200			nS	

• Clock synchronous master mode (High speed operating mode)

(Condition: $V_{DD}=3.5$ to 5.5 V, $V_{SS}=0$ V, $T_a=-40$ to 85°C , $V_{IH1}=0.8V_{DD}$, $V_{IL1}=0.2V_{DD}$, $V_{OH}=0.8V_{DD}$, $V_{OL}=0.2V_{DD}$)

Item	Symbol	Min.	Typ.	Max.	Unit	Note
Transmitting data output delay time	t _{sm} d			100	nS	
Receiving data input set-up time	t _{sm} s	250			nS	
Receiving data input hold time	t _{sm} h	200			nS	

• Clock synchronous master mode (Low power operating mode)

(Condition: $V_{DD}=1.8$ to 3.5 V, $V_{SS}=0$ V, $T_a=-40$ to 85°C , $V_{IH1}=0.8V_{DD}$, $V_{IL1}=0.2V_{DD}$, $V_{OH}=0.8V_{DD}$, $V_{OL}=0.2V_{DD}$)

Item	Symbol	Min.	Typ.	Max.	Unit	Note
Transmitting data output delay time	t _{sm} d			5	μS	
Receiving data input set-up time	t _{sm} s	10			μS	
Receiving data input hold time	t _{sm} h	5			μS	

• Clock synchronous slave mode (Normal operating mode)

(Condition: $V_{DD}=2.4$ to 5.5 V, $V_{SS}=0$ V, $T_a=-40$ to 85°C , $V_{IH1}=0.8V_{DD}$, $V_{IL1}=0.2V_{DD}$, $V_{OH}=0.8V_{DD}$, $V_{OL}=0.2V_{DD}$)

Item	Symbol	Min.	Typ.	Max.	Unit	Note
Transmitting data output delay time	t _{ss} d			500	μS	
Receiving data input set-up time	t _{ss} s	200			μS	
Receiving data input hold time	t _{ss} h	200			μS	

• Clock synchronous slave mode (High speed operating mode)

(Condition: $V_{DD}=3.5$ to $5.5V$, $V_{SS}=0V$, $T_a=-40$ to $85^{\circ}C$, $V_{IH1}=0.8V_{DD}$, $V_{IL1}=0.2V_{DD}$, $V_{OH}=0.8V_{DD}$, $V_{OL}=0.2V_{DD}$)

Item	Symbol	Min.	Typ.	Max.	Unit	Note
Transmitting data output delay time	t_{ssd}			250	nS	
Receiving data input set-up time	t_{sss}	100			nS	
Receiving data input hold time	t_{ssh}	100			nS	

• Clock synchronous slave mode (Low power operating mode)

(Condition: $V_{DD}=1.8$ to $3.5V$, $V_{SS}=0V$, $T_a=-40$ to $85^{\circ}C$, $V_{IH1}=0.8V_{DD}$, $V_{IL1}=0.2V_{DD}$, $V_{OH}=0.8V_{DD}$, $V_{OL}=0.2V_{DD}$)

Item	Symbol	Min.	Typ.	Max.	Unit	Note
Transmitting data output delay time	t_{ssd}			10	μS	
Receiving data input set-up time	t_{sss}	5			μS	
Receiving data input hold time	t_{ssh}	5			μS	

• Asynchronous system (All operating mode)

(Condition: $V_{DD}=1.8$ to $5.5V$, $V_{SS}=0V$, $T_a=-40$ to $85^{\circ}C$)

Item	Symbol	Min.	Typ.	Max.	Unit	Note
Start bit detection error time	t_{sa1}	0		$t/16$	S	1
Erroneous start bit detection range time	t_{sa2}	$9t/16$		$10t/16$	S	2

Note) 1 Start bit detection error time is a logical delay time from inputting the start bit until internal sampling begins operating.

(Time as far as AC is excluded.)

2 Erroneous start bit detection range time is a logical range to detect whether a LOW level (start bit) has been input again after a start bit has been detected and the internal sampling clock has started.

When a HIGH level is detected, the start bit detection circuit is reset and goes into a wait status until the next start bit.

(Time as far as AC is excluded.)

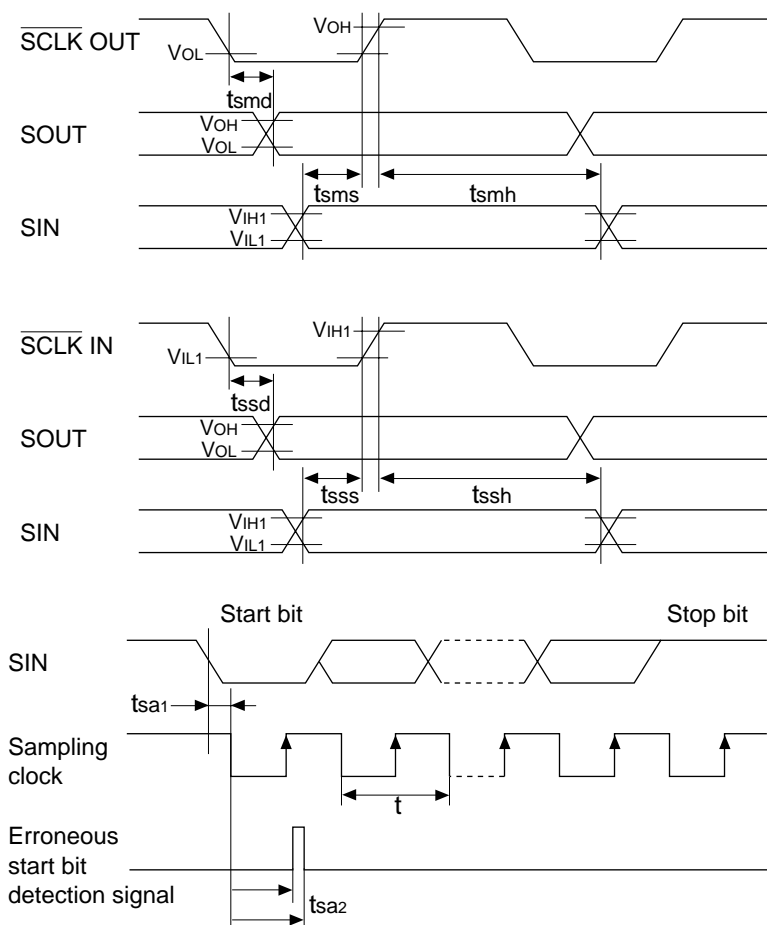

Input clock

• OSC1, OSC3 external clock (Normal operating mode)

(Condition: $V_{DD}=2.4$ to $5.5V$, $V_{SS}=0V$, $T_a=-40$ to $85^{\circ}C$, $V_{IH2}=1.6V$, $V_{IL2}=0.6V$)

Item	Symbol	Min.	Typ.	Max.	Unit	Note
OSC1 input clock time	Cycle time	t_{01cy}	12		32	μS
	"H" pulse width	t_{01h}	6		16	μS
	"L" pulse width	t_{01l}	6		16	μS
OSC3 input clock time	Cycle time	t_{03cy}	250		32,000	nS
	"H" pulse width	t_{03h}	125		16,000	nS
	"L" pulse width	t_{03l}	125		16,000	nS
Input clock rising time	t_{0sr}			25	nS	
Input clock falling time	t_{0sf}			25	nS	

• OSC1, OSC3 external clock (High speed operating mode)

(Condition: $V_{DD}=3.5$ to $5.5V$, $V_{SS}=0V$, $T_a=-40$ to $85^{\circ}C$, $V_{IH2}=2.4V$, $V_{IL2}=0.9V$)

Item	Symbol	Min.	Typ.	Max.	Unit	Note
OSC1 input clock	timeCycle time	t_{01cy}	12		32	μS
	"H" pulse width	t_{01h}	6		16	μS
	"L" pulse width	t_{01l}	6		16	μS
OSC3 input clock time		t_{03cy}	125		32,000	nS
		t_{03h}	62.5		16,000	nS
		t_{03l}	62.5		16,000	nS
Input clock rising time	t_{0sr}			25	nS	
Input clock falling time	t_{0sf}			25	nS	

• OSC1 external clock (Low power operating mode)

(Condition: $V_{DD}=1.8$ to $3.5V$, $V_{SS}=0V$, $T_a=-40$ to $85^{\circ}C$, $V_{IH2}=1.0V$, $V_{IL2}=0.3V$)

Item	Symbol	Min.	Typ.	Max.	Unit	Note
OSC1 input clock time	Cycle time	t_{01cy}	12		32	μS
	"H" pulse width	t_{01h}	6		16	μS
	"L" pulse width	t_{01l}	6		16	μS
Input clock rising time	t_{0sr}			25	nS	
Input clock falling time	t_{0sf}			25	nS	

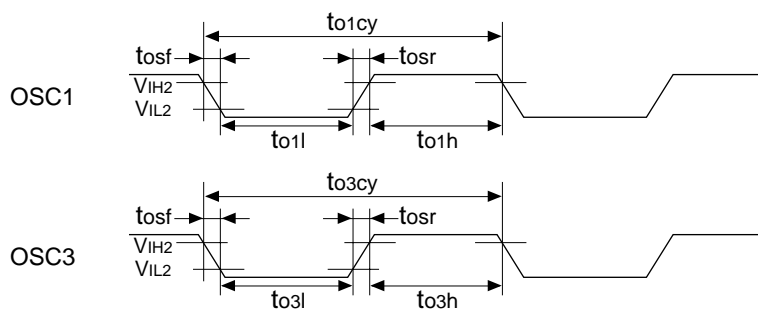

• SCLK, EVIN input clock (Normal operating mode)

(Condition: $V_{DD}=2.4$ to $5.5V$, $V_{SS}=0V$, $T_a=-40$ to $85^{\circ}C$, $V_{IH1}=0.8V_{DD}$, $V_{IL1}=0.2V_{DD}$)

Item	System	Min.	Typ.	Max.	Unit	Note
SCLK input clock time	Cycle time	t_{sccy}	4		μS	
	"H" pulse width	t_{sch}	2		μS	
	"L" pulse width	t_{scl}	2		μS	
EVIN input clock time (With noise rejector)	Cycle time	t_{evcy}	$64/f_{osc1}$		S	
	"H" pulse width	t_{evh}	$32/f_{osc1}$		S	
	"L" pulse width	t_{evl}	$32/f_{osc1}$		S	
EVIN input clock time (Without noise rejector)	Cycle time	t_{evcy}	4		μS	
	"H" pulse width	t_{evh}	2		μS	
	"L" pulse width	t_{evl}	2		μS	
Input clock rising time	t_{ckr}			25	nS	
Input clock falling time	t_{ckf}			25	nS	

• $\overline{\text{SCLK}}$, EVIN input clock (High speed operating mode)

(Condition: $V_{DD}=3.5$ to $5.5V$, $V_{SS}=0V$, $T_a=-40$ to $85^\circ C$, $V_{IH1}=0.8V_{DD}$, $V_{IL1}=0.2V_{DD}$)

Item	System	Min.	Typ.	Max.	Unit	Note
$\overline{\text{SCLK}}$ input clock time	Cycle time	t_{scyc}	2		μS	
	"H" pulse width	t_{sch}	1		μS	
	"L" pulse width	t_{scl}	1		μS	
EVIN input clock time (With noise rejector)	Cycle time	t_{evcy}	$64/f_{\text{osc1}}$		S	
	"H" pulse width	t_{evh}	$32/f_{\text{osc1}}$		S	
	"L" pulse width	t_{evl}	$32/f_{\text{osc1}}$		S	
EVIN input clock time (Without noise rejector)	Cycle time	t_{evcy}	2		μS	
	"H" pulse width	t_{evh}	1		μS	
	"L" pulse width	t_{evl}	1		μS	
Input clock rising time	t_{ckr}			25	nS	
Input clock falling time	t_{ckf}			25	nS	

• $\overline{\text{SCLK}}$, EVIN input clock (Low power operating mode)

(Condition: $V_{DD}=1.8$ to $3.5V$, $V_{SS}=0V$, $T_a=-40$ to $85^\circ C$, $V_{IH1}=0.8V_{DD}$, $V_{IL1}=0.2V_{DD}$)

Item	Symbol	Min.	Typ.	Max.	Unit	Note
$\overline{\text{SCLK}}$ input clock time	Cycle time	t_{scyc}	100		μS	
	"H" pulse width	t_{sch}	50		μS	
	"L" pulse width	t_{scl}	50		μS	
EVIN input clock time (With noise rejector)	Cycle time	t_{evcy}	$64/f_{\text{osc1}}$		S	
	"H" pulse width	t_{evh}	$32/f_{\text{osc1}}$		S	
	"L" pulse width	t_{evl}	$32/f_{\text{osc1}}$		S	
EVIN input clock time (Without noise rejector)	Cycle time	t_{evcy}	100		μS	
	"H" pulse width	t_{evh}	50		μS	
	"L" pulse width	t_{evl}	50		μS	
Input clock rising time	t_{ckr}			25	nS	
Input clock falling time	t_{ckf}			25	nS	

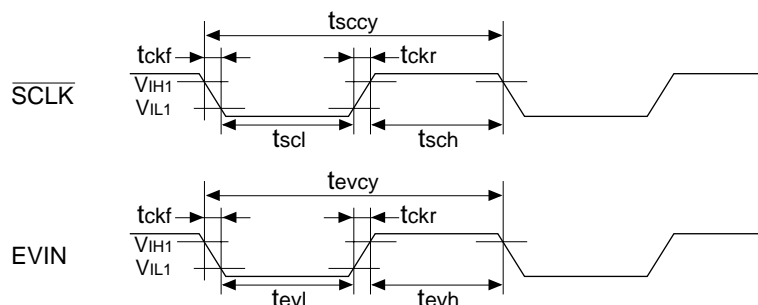

• $\overline{\text{RESET}}$ input clock (All operating mode)

(Condition: $V_{DD}=1.8$ to $5.5V$, $V_{SS}=0V$, $T_a=-40$ to $85^\circ C$, $V_{IH}=0.5V_{DD}$, $V_{IL}=0.1V_{DD}$)

Item	Symbol	Min.	Typ.	Max.	Unit	Note
$\overline{\text{RESET}}$ input time	t_{sr}	100			μS	

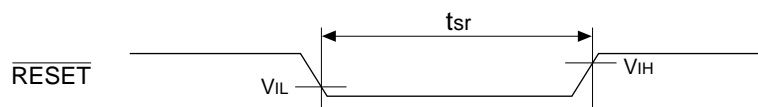

Power ON reset

(Condition: $V_{SS}=0V$, $T_a=-40$ to $85^\circ C$)

Item	Symbol	Min.	Typ.	Max.	Unit	Note
Operating power voltage	V_{sr}	2.4			V	
\overline{RESET} input time	t_{psr}	10			mS	

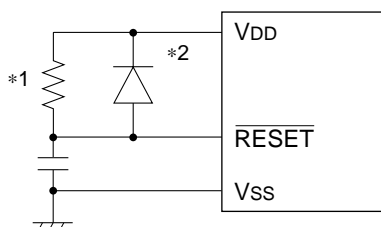
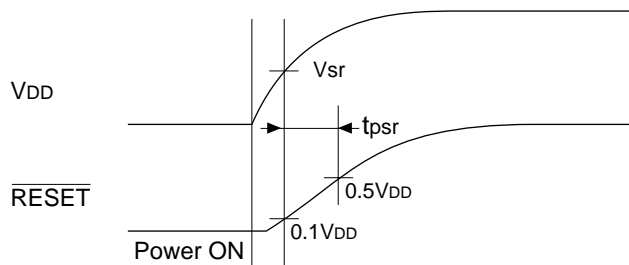

*1 When the built-in pull up resistor is not used.

*2 Because the potential of the \overline{RESET} terminal not reached V_{DD} level or higher.

Operating mode switching

(Condition: $V_{DD}=1.8$ to $5.5V$, $V_{SS}=0V$, $T_a=-40$ to $85^\circ C$)

Item	Symbol	Min.	Typ.	Max.	Unit	Note
Stabilization time	t_{vdc}	5			mS	1

Note) 1 Stabilization time is the time from switching on the operating mode until operating mode is stabilized. For example, when turning the OSC3 oscillation circuit on, stabilization time is needed after the operating mode is switched on.

● Oscillation Characteristics

Oscillation characteristics change depending on conditions (board pattern, components used, etc.). Use the following characteristics as reference values. In particular, when a ceramic oscillator is used for OSC3, use the oscillator manufacturer's recommended values for constants such as capacitance and resistance. The oscillation start time is important because it becomes the wait time when OSC3 clock is used. (If OSC3 is used as CPU clock before oscillation stabilizes, the CPU may malfunction.)

OSC1 (Crystal)

(Unless otherwise specified: V_{DD} =Within the operating voltage in each operating mode, $V_{SS}=0V$, $T_a=25^\circ C$,
Crystal oscillator=C2-TYPE*, $C_{G1}=25pF$ (external), C_{D1} =Built-in)

Item	Symbol	Condition	Min.	Typ.	Max.	Unit	Note
Oscillation start time	t_{sta}				3	S	
External gate capacitance	C_{G1}	Including board capacitance	5		30	pF	1
Built-in gate capacitance	C_{G1}	In case of the chip		12		pF	2
Built-in drain capacitance	C_{D1}	In case of the chip		12		pF	
Frequency/IC deviation	$\partial f/\partial IC$	$V_{DD} = \text{constant}$	-10		10	ppm	
Frequency/power voltage deviation	$\partial f/\partial V$				1	ppm/V	
Frequency adjustment range	$\partial f/\partial C_G$	$V_{DD} = \text{constant}$, $C_G = 5$ to 30 pF	25	55		ppm	1
Frequency/operating mode deviation	$\partial f/\partial MD$	$V_{DD} = \text{constant}$			20	ppm	

* C2-TYPE Made by Seiko Epson corporation

Note) 1 When crystal oscillation (external gate capacitor type) is selected by mask option.

2 When crystal oscillation (gate capacitor built-in type) is selected by mask option.

OSC1 (CR)(Unless otherwise specified: $V_{DD}=2.4$ to $5.5V$, $V_{SS}=0V$, $T_a=-40$ to $85^{\circ}C$)

Item	Symbol	Condition	Min.	Typ.	Max.	Unit	Note
Oscillation start time	tsta				3	mS	
Frequency/IC deviation	$\partial f/\partial IC$	R _{CR} = constant	-25		25	%	

OSC3 (Crystal)(Unless otherwise specified: V_{DD} =Within the operating voltage in each operating mode, $V_{SS}=0V$, $T_a=25^{\circ}C$,
Crystal oscillator=CA-301 4MHz / CA-301 8MHz*, $R_F=1M\Omega$, $C_{G2}=C_{D2}=15pF$)

Item	Symbol	Condition	Min.	Typ.	Max.	Unit	Note
Oscillation start time (Normal mode)	tsta	4.0 MHz crystal oscillator			20	mS	1
Oscillation start time (High speed mode)	tsta	8.0 MHz crystal oscillator			20	mS	1

* CA-301 4MHz / CA-301 8MHz Made by Seiko Epson corporation

Note) 1 The crystal oscillation start time changes by the crystal oscillator to be used, C_{G2} and C_{D2} .**OSC3 (Ceramic)**(Unless otherwise specified: V_{DD} =Within the operating voltage in each operating mode, $V_{SS}=0V$, $T_a=25^{\circ}C$,
Ceramic oscillator=CSA4.00MG / CSA8.00MTZ*, $R_F=1M\Omega$, $C_{G2}=C_{D2}=30pF$)

Item	Symbol	Condition	Min.	Typ.	Max.	Unit	Note
Oscillation start time (Normal mode)	tsta	4.0 MHz ceramic oscillator			5	mS	
Oscillation start time (High speed mode)	tsta	8.0 MHz ceramic oscillator			5	mS	

* CSA4.00MG / CSA8.00MTZ Made by Murata Mfg. corporation

OSC3 (CR)(Unless otherwise specified: V_{DD} =Within the operating voltage in each operating mode, $V_{SS}=0V$, $T_a=-40$ to $85^{\circ}C$)

Item	Symbol	Condition	Min.	Typ.	Max.	Unit	Note
Oscillation start time (Normal mode)	tsta				1	mS	
Oscillation start time (High speed mode)	tsta				1	mS	
Frequency/IC deviation (Normal mode)	$\partial f/\partial IC$	R _{CR} = constant	-25		25	%	
Frequency/IC deviation (High speed mode)	$\partial f/\partial IC$	R _{CR} = constant	-25		25	%	

● A/D Converter Characteristics

The following characteristics apply to the plastic package model only.

(Unless otherwise specified: $V_{DD}=AV_{DD}=AV_{REF}=5.0V$, $V_{SS}=AV_{SS}=AGND=0V$, $f_{OSC1}=32.768kHz$, $f_{OSC3}=4.0MHz$, $T_a=25^{\circ}C$)

Item	Symbol	Condition	Min.	Typ.	Max.	Unit	Note
Zero-scale error	Ezs	$V_{DD}=AV_{DD}=AV_{REF}=2.7$ to $5.5V$, ADCLK=2MHz, $T_a=25^{\circ}C$	-1.50		1.50	LSB	
Full-scale error	Efs		-1.50		1.50	LSB	
Non-linearity error	EI		-1.50		1.50	LSB	
Total error	Et		-3.00		3.00	LSB	
A/D converter current consumption	I _{AD}	$V_{DD}=AV_{DD}=AV_{REF}=3.0V$, ADCLK=2MHz, $T_a=25^{\circ}C$ AV _{REF} and ADCLK divider current not included		0.50	1.00	mA	
		$V_{DD}=AV_{DD}=AV_{REF}=5.0V$, ADCLK=2MHz, $T_a=25^{\circ}C$ AV _{REF} and ADCLK divider current not included		1.80	3.50	mA	
Input clock frequency	f	$V_{DD}=AV_{DD}=AV_{REF}=2.7$ to $3.0V$, $T_a=25^{\circ}C$			2	MHz	
		$V_{DD}=AV_{DD}=AV_{REF}=3.0$ to $5.5V$, $T_a=25^{\circ}C$			4	MHz	

* Zero-scale error: Ezs = deviation from the ideal value at zero point

* Full-scale error: Efs = deviation from the ideal value at the full scale point

* Non-linearity error: EI = deviation of the real conversion curve from the end point line

* Total error: Et = max(Ezs, Efs, Eabs), Eabs = deviation from the ideal line (including quantization error)

E0C88816

■ BASIC EXTERNAL CONNECTION DIAGRAM

● When Vc2 standard and 1/5 bias are selected

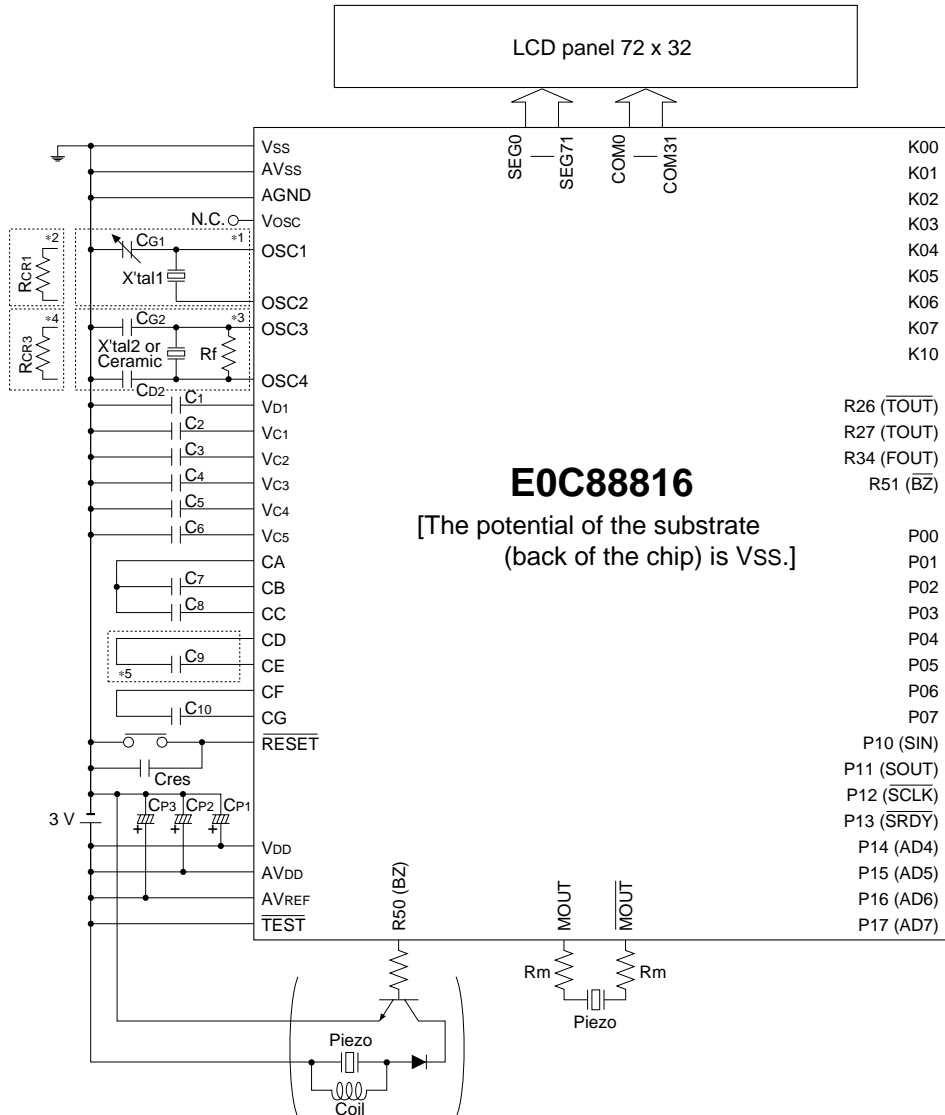

Recommended values for external parts

Symbol	Name	Recommended value
X'tal1	Crystal oscillator	32.768 kHz, CI(Max.)=35 kΩ
CG1	Trimmer capacitor	5-30 pF
RCR1	Resistor for CR oscillation	1 MΩ
X'tal2	Crystal oscillator	4 MHz
Ceramic	Ceramic oscillator	4 MHz
Rf	Feedback resistor	1 MΩ
CG2	Gate capacitor	15 pF (Crystal oscillator) 30 pF (Ceramic oscillator)
Cd2	Drain capacitor	15 pF (Crystal oscillator) 30 pF (Ceramic oscillator)
RCR3	Resistor for CR oscillation	20 kΩ

Symbol	Name	Recommended value
C1	Capacitor between Vss and Vd1	0.1 μF
C2	Capacitor between Vss and Vc1	0.1 μF
C3	Capacitor between Vss and Vc2	0.1 μF
C4	Capacitor between Vss and Vc3	0.1 μF
C5	Capacitor between Vss and Vc4	0.1 μF
C6	Capacitor between Vss and Vc5	0.1 μF
C7-C10	Booster/reducer capacitors	0.1 μF
CP1-CP3	Capacitors for power supply	3.3 μF
Cres	Capacitor for RESET terminal	0.47 μF
Rm	Protective resistors for piezo	100 Ω

* The connection diagram shown above is an example of when mask option settings are as follows:

LCD power source: Internal power supply, RESET terminal: With pull-up resistor,

R51 specification: General-purpose output port

*1 OSC1 = Crystal oscillation, *2 OSC1 = CR oscillation, *3 OSC3 = Crystal/Ceramic oscillation, *4 OSC3 = CR oscillation,

*5 Unnecessary for 1/4 bias drive

Note: The above table is simply an example, and is not guaranteed to work.

■ DIAGRAM OF PAD LAYOUT

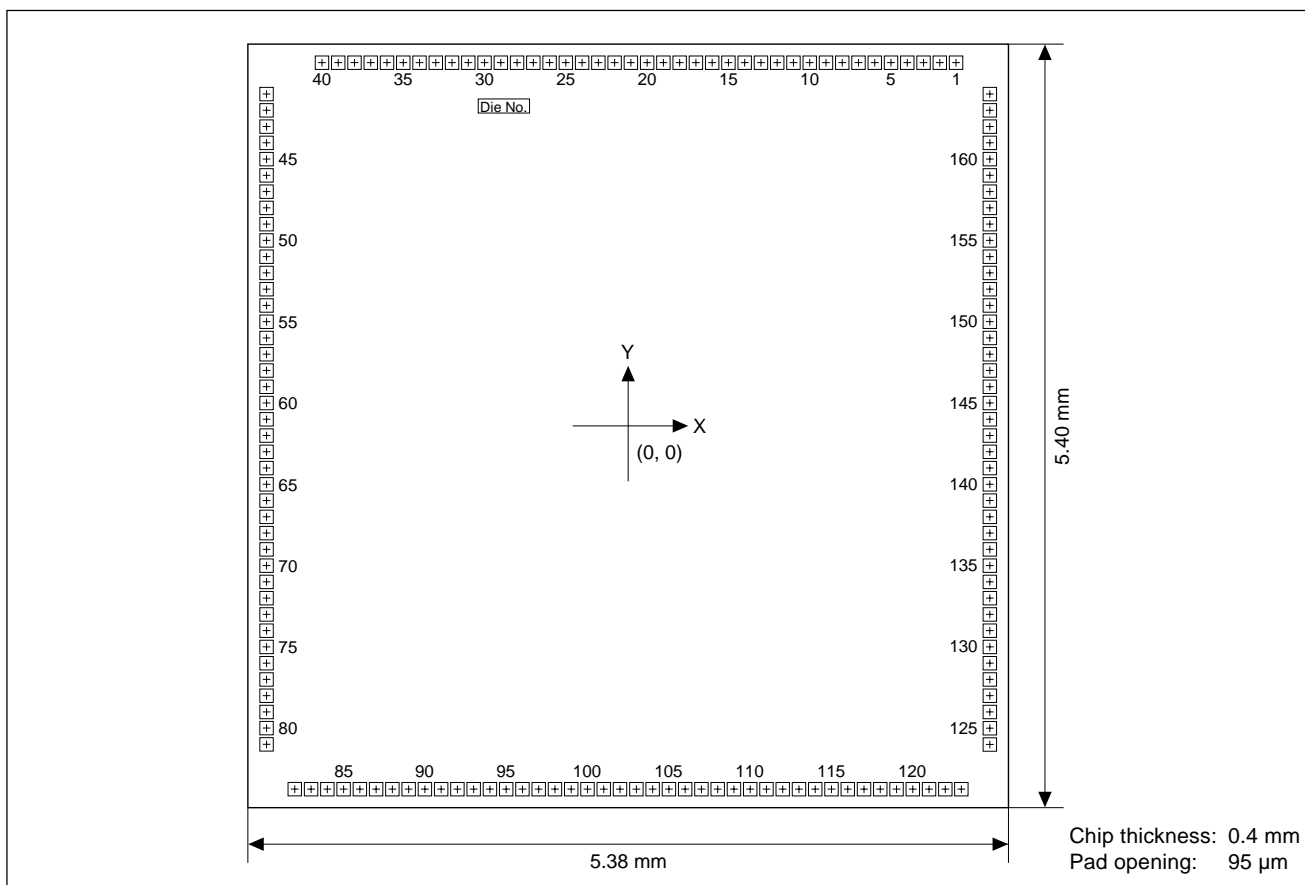

■ PAD COORDINATES

Pad No.	Pad name	X	Y	Pad No.	Pad name	X	Y	Pad No.	Pad name	X	Y
1	Vc3	2,319	2,569	27	P13/SRDY	-671	2,569	53	COM3	-2,558	-2,558
2	Vc2	2,204	2,569	28	P12/SCLK	-786	2,569	54	COM4	-2,558	-2,558
3	Vc1	2,089	2,569	29	P11/SOUT	-901	2,569	55	COM5	-2,558	-2,558
4	OSC3	1,974	2,569	30	P10/SIN	-1,016	2,569	56	COM6	2,558	622
5	OSC4	1,859	2,569	31	AVDd	-1,131	2,569	57	COM7	-2,558	507
6	VD1	1,744	2,569	32	AGND	-1,246	2,569	58	COM8	-2,558	392
7	VDD	1,629	2,569	33	AVss	-1,361	2,569	59	COM9	-2,558	277
8	Vss	1,514	2,569	34	AVREF	-1,476	2,569	60	COM10	-2,558	162
9	Vosc	1,399	2,569	35	P07	-1,591	2,569	61	COM11	-2,558	47
10	OSC1	1,284	2,569	36	P06	-1,706	2,569	62	COM12	-2,558	-68
11	OSC2	1,169	2,569	37	P05	-1,821	2,569	63	COM13	-2,558	-183
12	TEST	1,054	2,569	38	P04	-1,936	2,569	64	COM14	-2,558	-298
13	RESET	939	2,569	39	P03	-2,051	2,569	65	COM15	-2,558	-413
14	K10/EVIN	824	2,569	40	P02	-2,166	2,569	66	SEG0	-2,558	-528
15	K07	709	2,569	41	P01	-2,558	-2,558	67	SEG1	-2,558	-643
16	K06	594	2,569	42	P00	-2,558	-2,558	68	SEG2	-2,558	-758
17	K05	479	2,569	43	MOUt	-2,558	-2,558	69	SEG3	-2,558	-873
18	K04	364	2,569	44	MOU	-2,558	-2,558	70	SEG4	-2,558	-988
19	K03	249	2,569	45	R26/TOUT	-2,558	-2,558	71	SEG5	-2,558	-1,103
20	K02	134	2,569	46	R27/TOUT	-2,558	-2,558	72	SEG6	-2,558	-1,218
21	K01	19	2,569	47	R34/FOUT	-2,558	-2,558	73	SEG7	-2,558	-1,333
22	K00	-96	2,569	48	R50/BZ	-2,558	-2,558	74	SEG8	-2,558	-1,448
23	P17/AD7	-211	2,569	49	R51/BZ	-2,558	-2,558	75	SEG9	-2,558	-1,563
24	P16/AD6	-326	2,569	50	COM0	-2,558	-2,558	76	SEG10	-2,558	-1,678
25	P15/AD5	-441	2,569	51	COM1	-2,558	-2,558	77	SEG11	-2,558	-1,793
26	P14/AD4	-556	2,569	52	COM2	-2,558	-2,558	78	SEG12	-2,558	-1,908

E0C88816

Pad No.	Pad name	X	Y	Pad No.	Pad name	X	Y	Pad No.	Pad name	X	Y
79	SEG13	-2,558	-2,023	108	SEG41	633	-2,569	137	SEG69	2,558	-758
80	SEG14	-2,558	-2,137	109	SEG42	748	-2,569	138	SEG70	2,558	-643
81	SEG15	-2,558	-2,252	110	SEG43	863	-2,569	139	SEG71	2,558	-528
82	*	*	*	111	SEG44	978	-2,569	140	COM31/SEG72	2,558	-413
83	SEG16	-2,243	-2,569	112	SEG45	1,093	-2,569	141	COM30/SEG73	2,558	-298
84	SEG17	-2,128	-2,569	113	SEG46	1,208	-2,569	142	COM29/SEG74	2,558	-183
85	SEG18	-2,013	-2,569	114	SEG47	1,323	-2,569	143	COM28/SEG75	2,558	-68
86	SEG19	-1,898	-2,569	115	SEG48	1,438	-2,569	144	COM27/SEG76	2,558	47
87	SEG20	-1,783	-2,569	116	SEG49	1,553	-2,569	145	COM26/SEG77	2,558	162
88	SEG21	-1,668	-2,569	117	SEG50	1,668	-2,569	146	COM25/SEG78	2,558	277
89	SEG22	-1,553	-2,569	118	SEG51	1,783	-2,569	147	COM24/SEG79	2,558	392
90	SEG23	-1,438	-2,569	119	SEG52	1,898	-2,569	148	COM23/SEG80	2,558	507
91	SEG24	-1,323	-2,569	120	SEG53	2,013	-2,569	149	COM22/SEG81	2,558	622
92	SEG25	-1,208	-2,569	121	SEG54	2,128	-2,569	150	COM21/SEG82	2,558	737
93	SEG26	-1,093	-2,569	122	SEG55	2,243	-2,569	151	COM20/SEG83	2,558	852
94	SEG27	-978	-2,569	123	*	*	*	152	COM19/SEG84	2,558	967
95	SEG28	-863	-2,569	124	SEG56	2,558	2,253	153	COM18/SEG85	2,558	1,082
96	SEG29	-748	-2,569	125	SEG57	2,558	-2,138	154	COM17/SEG86	2,558	1,197
97	SEG30	-633	-2,569	126	SEG58	2,558	-2,023	155	COM16/SEG87	2,558	1,312
98	SEG31	-518	-2,569	127	SEG59	2,558	-1,908	156	CG	2,558	1,427
99	SEG32	-403	-2,569	128	SEG60	2,558	-1,793	157	CF	2,558	1,542
100	SEG33	-288	-2,569	129	SEG61	2,558	-1,678	158	CE	2,558	1,657
101	SEG34	-173	-2,569	130	SEG62	2,558	-1,563	159	CD	2,558	1,772
102	SEG35	-58	-2,569	131	SEG63	2,558	-1,448	160	CC	2,558	1,887
103	SEG36	58	-2,569	132	SEG64	2,558	-1,333	161	CB	2,558	2,002
104	SEG37	173	-2,569	133	SEG65	2,558	-1,218	162	CA	2,558	2,117
105	SEG38	288	-2,569	134	SEG66	2,558	-1,103	163	Vc5	2,558	2,232
106	SEG39	403	-2,569	135	SEG67	2,558	-988	164	Vc4	2,558	2,347
107	SEG40	518	-2,569	136	SEG68	2,558	-873				

* Do not bond No.82 and 123 pads since they are used for factory inspection at shipment.

■ PACKAGE DIMENSIONS

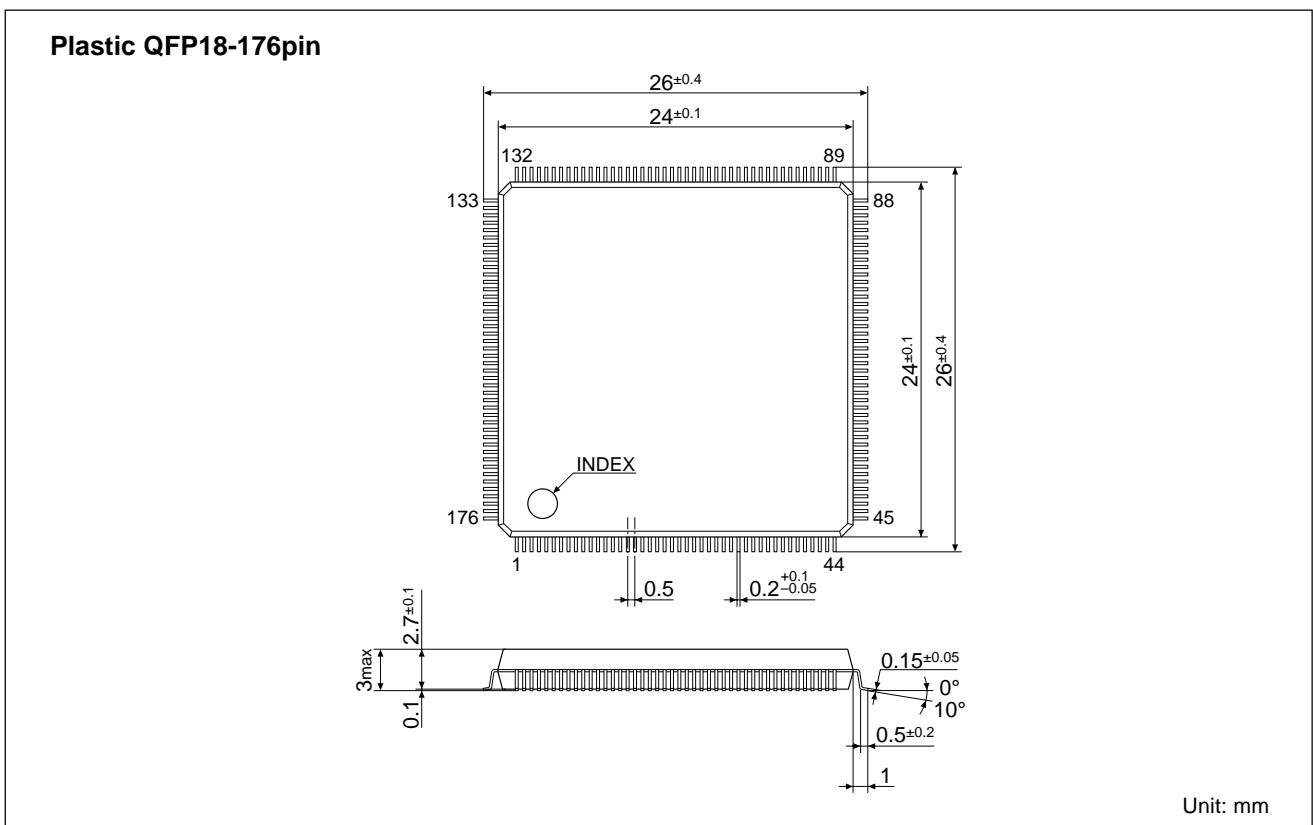

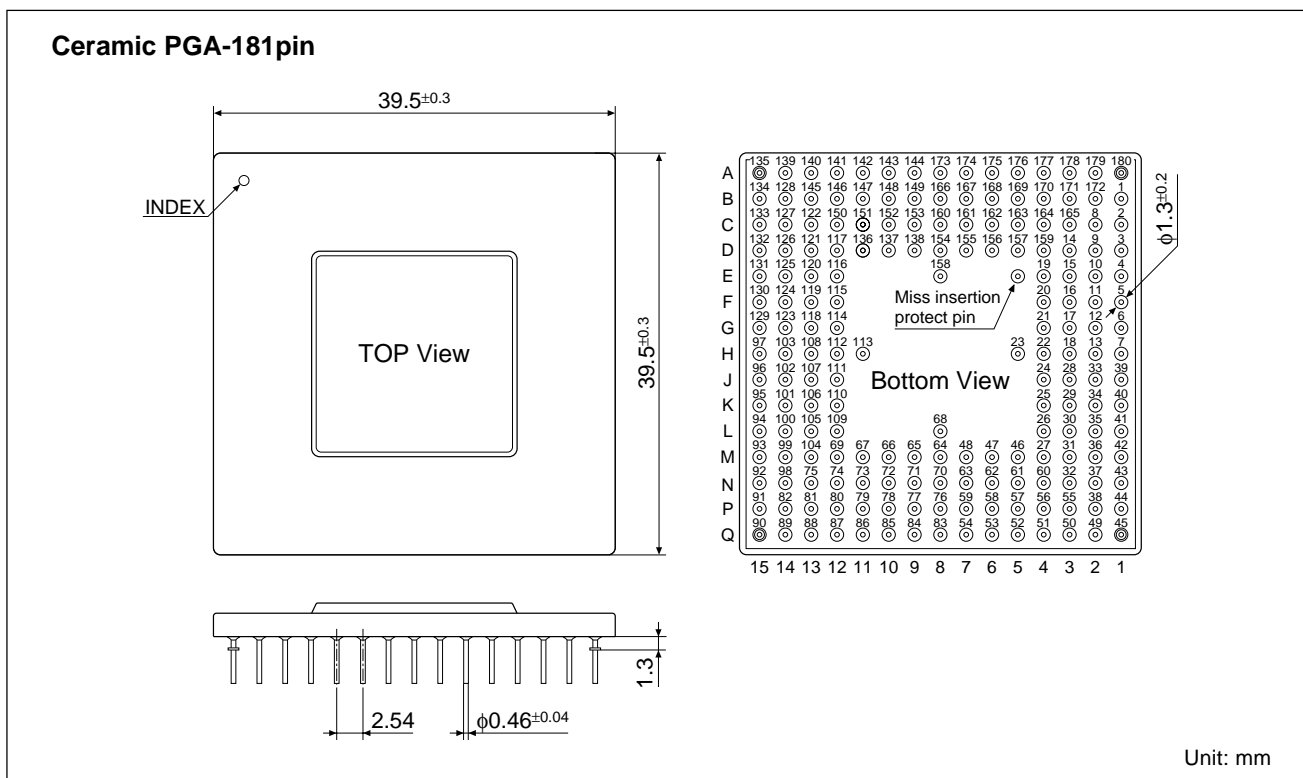

Pin No.	Pin name	Pin No.	Pin name	Pin No.	Pin name	Pin No.	Pin name	Pin No.	Pin name
1	N.C.	37	SEG49	73	COM22/SEG81	109	K06	145	R50/BZ
2	N.C.	38	SEG50	74	COM21/SEG82	110	K05	146	R51/BZ
3	N.C.	39	SEG51	75	COM20/SEG83	111	K04	147	COM0
4	SEG16	40	SEG52	76	COM19/SEG84	112	K03	148	COM1
5	SEG17	41	SEG53	77	COM18/SEG85	113	K02	149	COM2
6	SEG18	42	SEG54	78	COM17/SEG86	114	K01	150	COM3
7	SEG19	43	SEG55	79	COM16/SEG87	115	K00	151	COM4
8	SEG20	44	N.C.	80	CG	116	P17/AD7	152	COM5
9	SEG21	45	N.C.	81	CF	117	P16/AD6	153	COM6
10	SEG22	46	N.C.	82	CE	118	P15/AD5	154	COM7
11	SEG23	47	N.C.	83	CD	119	P14/AD4	155	COM8
12	SEG24	48	SEG56	84	CC	120	P13/SRDY	156	COM9
13	SEG25	49	SEG57	85	CB	121	P12/SCLK	157	COM10
14	SEG26	50	SEG58	86	CA	122	P11/SOUT	158	COM11
15	SEG27	51	SEG59	87	Vc5	123	P10/SIN	159	COM12
16	SEG28	52	SEG60	88	Vc4	124	AVDD	160	COM13
17	SEG29	53	SEG61	89	N.C.	125	AGND	161	COM14
18	SEG30	54	SEG62	90	N.C.	126	AVss	162	COM15
19	SEG31	55	SEG63	91	N.C.	127	AVREF	163	SEG0
20	SEG32	56	SEG64	92	N.C.	128	P07	164	SEG1
21	SEG33	57	SEG65	93	N.C.	129	P06	165	SEG2
22	SEG34	58	SEG66	94	Vc3	130	P05	166	SEG3
23	SEG35	59	SEG67	95	Vc2	131	P04	167	SEG4
24	SEG36	60	SEG68	96	Vc1	132	P03	168	SEG5
25	SEG37	61	SEG69	97	OSC3	133	P02	169	SEG6
26	SEG38	62	SEG70	98	OSC4	134	N.C.	170	SEG7
27	SEG39	63	SEG71	99	Vd1	135	N.C.	171	SEG8
28	SEG40	64	COM31/SEG72	100	VDD	136	N.C.	172	SEG9
29	SEG41	65	COM30/SEG73	101	Vss	137	N.C.	173	SEG10
30	SEG42	66	COM29/SEG74	102	Vosc	138	P01	174	SEG11
31	SEG43	67	COM28/SEG75	103	OSC1	139	P00	175	SEG12
32	SEG44	68	COM27/SEG76	104	OSC2	140	MOUT	176	SEG13
33	SEG45	69	COM26/SEG77	105	TEST	141	MOUT	177	SEG14
34	SEG46	70	COM25/SEG78	106	RESET	142	R26/TOUT	178	SEG15
35	SEG47	71	COM24/SEG79	107	K10/EVIN	143	R27/TOUT	179	N.C.
36	SEG48	72	COM23/SEG80	108	K07	144	R34/FOUT	180	N.C.

N.C.: No Connection

E0C88816

NOTICE:

No part of this material may be reproduced or duplicated in any form or by any means without the written permission of Seiko Epson. Seiko Epson reserves the right to make changes to this material without notice. Seiko Epson does not assume any liability of any kind arising out of any inaccuracies contained in this material or due to its application or use in any product or circuit and, further, there is no representation that this material is applicable to products requiring high level reliability, such as, medical products. Moreover, no license to any intellectual property rights is granted by implication or otherwise, and there is no representation or warranty that anything made in accordance with this material will be free from any patent or copyright infringement of a third party. This material or portions thereof may contain technology or the subject relating to strategic products under the control of the Foreign Exchange and Foreign Trade Law of Japan and may require an export license from the Ministry of International Trade and Industry or other approval from another government agency.

© Seiko Epson Corporation 2000 All right reserved.

SEIKO EPSON CORPORATION

ELECTRONIC DEVICES MARKETING DIVISION

IC Marketing & Engineering Group

ED International Marketing Department Europe & U.S.A.

421-8, Hino, Hino-shi, Tokyo 191-8501, JAPAN
Phone : 042-587-5812 FAX : 042-587-5564

ED International Marketing Department Asia

421-8, Hino, Hino-shi, Tokyo 191-8501, JAPAN
Phone : 042-587-5814 FAX : 042-587-5110

■ EPSON Electronic Devices Website

<http://www.epson.co.jp/device/>

