

CMOS 8-BIT SINGLE CHIP MICROCOMPUTER

***E0C88348/317/316/308 TECHNICAL MANUAL***

**E0C88348/317/316/308 Technical Hardware**

**E0C88348/317/316/308 Technical Software**



## ***NOTICE***

---

*No part of this material may be reproduced or duplicated in any form or by any means without the written permission of Seiko Epson. Seiko Epson reserves the right to make changes to this material without notice. Seiko Epson does not assume any liability of any kind arising out of any inaccuracies contained in this material or due to its application or use in any product or circuit and, further, there is no representation that this material is applicable to products requiring high level reliability, such as medical products. Moreover, no license to any intellectual property rights is granted by implication or otherwise, and there is no representation or warranty that anything made in accordance with this material will be free from any patent or copyright infringement of a third party. This material or portions thereof may contain technology or the subject relating to strategic products under the control of the Foreign Exchange and Foreign Trade Law of Japan and may require an export license from the Ministry of International Trade and Industry or other approval from another government agency. Please note that "EOC" is the new name for the old product "SMC". If "SMC" appears in other manuals understand that it now reads "EOC".*

CMOS 8-bit Single Chip Microcomputer

# **E0C88348/317/316/308 Technical Manual**

---

## **Introduction**

This Manual contains separate descriptions of the hardware and software of the E0C88348/317/316/308 CMOS 8-bit single chip microcomputers.

## **I. E0C88348/317/316/308 Technical Hardware**

This section of the Manual describes the functions, circuit configuration and control system of the E0C88348/317/316/308.

## **II. E0C88348/317/316/308 Technical Software**

This section of the Manual describes the programming of the E0C88348/317/316/308.

***I E0C88348/317/316/308  
Technical Hardware***

## Contents

<b>1</b>	<b>INTRODUCTION</b> .....	<b>I-1</b>
1.1	Configuration .....	I-1
1.2	Features .....	I-2
1.3	Block Diagram .....	I-3
1.4	Pin Layout Diagram .....	I-5
<b>2</b>	<b>POWER SUPPLY</b> .....	<b>I-13</b>
2.1	Operating Voltage .....	I-13
2.2	Internal Power Supply Circuit .....	I-13
2.3	Heavy Load Protection Mode .....	I-14
<b>3</b>	<b>CPU AND BUS CONFIGURATION</b> .....	<b>I-15</b>
3.1	CPU .....	I-15
3.2	Internal Memory .....	I-15
3.2.1	ROM .....	I-15
3.2.2	RAM .....	I-15
3.2.3	I/O memory .....	I-15
3.2.4	Display memory .....	I-16
3.3	Exception Processing Vectors .....	I-16
3.4	CC (Customized Condition Flag) .....	I-16
3.5	Chip Mode .....	I-17
3.5.1	MCU mode and MPU mode .....	I-17
3.5.2	Bus mode .....	I-17
3.6	External Bus .....	I-21
3.6.1	Data bus .....	I-21
3.6.2	Address bus .....	I-21
3.6.3	Read ( $\overline{RD}$ )/write ( $\overline{WR}$ ) signals .....	I-22
3.6.4	Chip enable ( $\overline{CE}$ ) signal .....	I-22
3.6.5	WAIT control .....	I-24
3.6.6	Bus authority release state .....	I-25
<b>4</b>	<b>INITIAL RESET</b> .....	<b>I-26</b>
4.1	Initial Reset Factors .....	I-26
4.1.1	$\overline{RESET}$ terminal .....	I-27
4.1.2	Simultaneous LOW level input at input port terminals K00–K03 .....	I-27
4.1.3	Supply voltage detection (SVD) circuit .....	I-27
4.1.4	Initial reset sequence .....	I-27
4.2	Initial Settings After Initial Reset .....	I-28
<b>5</b>	<b>PERIPHERAL CIRCUITS AND THEIR OPERATION</b> .....	<b>I-29</b>
5.1	I/O Memory Map .....	I-30
5.2	System Controller and Bus Control .....	I-42
5.2.1	Bus mode settings .....	I-42
5.2.2	Address decoder ( $\overline{CE}$ output) settings .....	I-44
5.2.3	WAIT state settings .....	I-45
5.2.4	Setting the bus authority release request signal .....	I-45
5.2.5	Stack page setting .....	I-45
5.2.6	Control of system controller .....	I-46
5.2.7	Programming notes .....	I-49

- 5.3 Watchdog Timer ..... I-50
  - 5.3.1 Configuration of watchdog timer ..... I-50
  - 5.3.2 Interrupt function ..... I-50
  - 5.3.3 Control of watchdog timer ..... I-50
  - 5.3.4 Programming notes ..... I-50
- 5.4 Oscillation Circuits and Operating Mode ..... I-51
  - 5.4.1 Configuration of oscillation circuits ..... I-51
  - 5.4.2 Mask option ..... I-51
  - 5.4.3 OSC1 oscillation circuit ..... I-51
  - 5.4.4 OSC3 oscillation circuit ..... I-52
  - 5.4.5 Operating mode ..... I-52
  - 5.4.6 Switching the CPU clocks ..... I-53
  - 5.4.7 Control of oscillation circuit and operating mode ..... I-54
  - 5.4.8 Programming notes ..... I-55
- 5.5 Input Ports (K ports) ..... I-56
  - 5.5.1 Configuration of input ports ..... I-56
  - 5.5.2 Mask option ..... I-56
  - 5.5.3 Interrupt function and input comparison register ..... I-57
  - 5.5.4 Control of input ports ..... I-59
  - 5.5.5 Programming note ..... I-61
- 5.6 Output Ports (R ports) ..... I-62
  - 5.6.1 Configuration of output ports ..... I-62
  - 5.6.2 Mask option ..... I-63
  - 5.6.3 High impedance control ..... I-63
  - 5.6.4 DC output ..... I-64
  - 5.6.5 Special output ..... I-64
  - 5.6.6 Control of output ports ..... I-66
  - 5.6.7 Programming notes ..... I-70
- 5.7 I/O Ports (P ports) ..... I-71
  - 5.7.1 Configuration of I/O ports ..... I-71
  - 5.7.2 Mask option ..... I-71
  - 5.7.3 I/O control registers and I/O mode ..... I-72
  - 5.7.4 Control of I/O ports ..... I-72
  - 5.7.5 Programming notes ..... I-73
- 5.8 Serial Interface ..... I-74
  - 5.8.1 Configuration of serial interface ..... I-74
  - 5.8.2 Mask option ..... I-75
  - 5.8.3 Transfer modes ..... I-75
  - 5.8.4 Clock source ..... I-76
  - 5.8.5 Transmit-receive control ..... I-77
  - 5.8.6 Operation of clock synchronous transfer ..... I-78
  - 5.8.7 Operation of asynchronous transfer ..... I-82
  - 5.8.8 Interrupt function ..... I-86
  - 5.8.9 Control of serial interface ..... I-88
  - 5.8.10 Programming notes ..... I-92
- 5.9 Clock Timer ..... I-93
  - 5.9.1 Configuration of clock timer ..... I-93
  - 5.9.2 Interrupt function ..... I-93
  - 5.9.3 Control of clock timer ..... I-95
  - 5.9.4 Programming notes ..... I-97
- 5.10 Stopwatch Timer ..... I-98
  - 5.10.1 Configuration of stopwatch timer ..... I-98
  - 5.10.2 Count up pattern ..... I-98
  - 5.10.3 Interrupt function ..... I-99
  - 5.10.4 Control of stopwatch timer ..... I-100
  - 5.10.5 Programming notes ..... I-102

5.11	<i>Programmable Timer</i> .....	I-103
	5.11.1 <i>Configuration of programmable timer</i> .....	I-103
	5.11.2 <i>Count operation and setting basic mode</i> .....	I-103
	5.11.3 <i>Setting of input clock</i> .....	I-105
	5.11.4 <i>Timer mode</i> .....	I-105
	5.11.5 <i>Event counter mode</i> .....	I-106
	5.11.6 <i>Pulse width measurement timer mode</i> .....	I-106
	5.11.7 <i>Interrupt function</i> .....	I-107
	5.11.8 <i>Setting of TOUT output</i> .....	I-107
	5.11.9 <i>Transmission rate setting of serial interface</i> .....	I-108
	5.11.10 <i>Control of programmable timer</i> .....	I-109
	5.11.11 <i>Programming notes</i> .....	I-115
5.12	<i>LCD Controller</i> .....	I-116
	5.12.1 <i>Configuration of LCD controller</i> .....	I-116
	5.12.2 <i>Mask option</i> .....	I-116
	5.12.3 <i>LCD power supply</i> .....	I-116
	5.12.4 <i>LCD driver</i> .....	I-117
	5.12.5 <i>Display memory</i> .....	I-120
	5.12.6 <i>Display control</i> .....	I-127
	5.12.7 <i>CL and FR outputs</i> .....	I-127
	5.12.8 <i>Control of LCD controller</i> .....	I-128
	5.12.9 <i>Programming notes</i> .....	I-129
5.13	<i>Sound Generator</i> .....	I-130
	5.13.1 <i>Configuration of sound generator</i> .....	I-130
	5.13.2 <i>Control of buzzer output</i> .....	I-130
	5.13.3 <i>Setting of buzzer frequency and sound level</i> .....	I-131
	5.13.4 <i>Digital envelope</i> .....	I-131
	5.13.5 <i>One-shot output</i> .....	I-132
	5.13.6 <i>Control of sound generator</i> .....	I-133
	5.13.7 <i>Programming notes</i> .....	I-135
5.14	<i>Analog Comparator</i> .....	I-136
	5.14.1 <i>Configuration of analog comparator</i> .....	I-136
	5.14.2 <i>Mask option</i> .....	I-136
	5.14.3 <i>Analog comparator operation</i> .....	I-136
	5.14.4 <i>Control of analog comparator</i> .....	I-137
	5.14.5 <i>Programming notes</i> .....	I-137
5.15	<i>Supply Voltage Detection (SVD) Circuit</i> .....	I-138
	5.15.1 <i>Configuration of SVD circuit</i> .....	I-138
	5.15.2 <i>Operation of SVD circuit</i> .....	I-138
	5.15.3 <i>Control of SVD circuit</i> .....	I-140
	5.15.4 <i>Programming notes</i> .....	I-141
5.16	<i>Interrupt and Standby Status</i> .....	I-142
	5.16.1 <i>Interrupt generation conditions</i> .....	I-143
	5.16.2 <i>Interrupt factor flag</i> .....	I-143
	5.16.3 <i>Interrupt enable register</i> .....	I-144
	5.16.4 <i>Interrupt priority register and interrupt priority level</i> .....	I-144
	5.16.5 <i>Exception processing vectors</i> .....	I-145
	5.16.6 <i>Control of interrupt</i> .....	I-146
	5.16.7 <i>Programming notes</i> .....	I-147
5.17	<i>Notes for Low Current Consumption</i> .....	I-148
<b>6</b>	<b><i>BASIC EXTERNAL WIRING DIAGRAM</i></b> .....	<b>I-149</b>
<b>7</b>	<b><i>ELECTRICAL CHARACTERISTICS</i></b> .....	<b>I-150</b>
	7.1 <i>Absolute Maximum Rating</i> .....	I-150
	7.2 <i>Recommended Operating Conditions</i> .....	I-151

**CONTENTS**

- 7.3 *DC Characteristics* ..... I-152
- 7.4 *Analog Circuit Characteristics* ..... I-153
- 7.5 *Power Current Consumption* ..... I-155
- 7.6 *AC Characteristics* ..... I-156
- 7.7 *Oscillation Characteristics* ..... I-163
- 7.8 *Characteristics Curves (reference value)* ..... I-164
- 8 PACKAGE** ..... **I-180**
  - 8.1 *Plastic Package* ..... I-180
  - 8.2 *Ceramic Package* ..... I-182
- 9 PAD LAYOUT** ..... **I-183**
  - 9.1 *Diagram of Pad Layout* ..... I-183
  - 9.2 *Pad Coordinates* ..... I-187
- 10 PRECAUTIONS ON MOUNTING** ..... **I-191**



# 1 INTRODUCTION

The E0C88348, E0C88317, E0C88316 and E0C88308 microcomputers feature the E0C88 (Model 3) CMOS 8-bit core CPU along with ROM, RAM, three different timers and a serial interface with optional asynchronization or clock synchronization.

These devices are fully operable over a wide range of voltages, and can perform high speed operations even at low voltage. Like all the equipment in the E0C Family, these microcomputers have low power consumption.

A 19-bit external address bus and 4 bits chip enable signals make it possible for these microcomputers to control up to  $512K \times 4$  bytes of memory, making them ideal for high performance data bank systems.

## 1.1 Configuration

In this manual, the E0C883xx is associated with E0C88348, E0C88317, E0C88316 and E0C88308. In these four models, there are differences in built-in ROM capacity, built-in RAM capacity, number of input ports, number of output ports, number of LCD drive segments and bus authority release functions, but the other peripheral circuits are made with the same configuration.

Table 1.1.1 Configuration

Model	Internal ROM	Internal RAM	Input port	Output port*1	LCD segment*2	Bus authority release function
<b>E0C88348</b>	48K bytes	2K bytes	10 bits	9 bits	1,632 (Max.)	Available
<b>E0C88317</b>	16K bytes	2K bytes	10 bits	9 bits	1,632 (Max.)	Available
<b>E0C88316</b>	16K bytes	2K bytes	10 bits	9 bits	1,632 (Max.)	Available
<b>E0C88308</b>	8K bytes	256 bytes	9 bits	5 bits	1,312 (Max.)	Not available

\*1 The terminals shared with the external bus are not included.

\*2 Maximum number of drive segment when the 32 commons is selected.

## 1.2 Features

Table 1.2.1 lists the features of the E0C883xx.

Table 1.2.1 Main features

Model	E0C88348	E0C88317	E0C88316	E0C88308
Core CPU	E0C88 (MODEL3) CMOS 8-bit core CPU			
OSC1 Oscillation circuit	Crystal oscillation circuit/CR oscillation circuit/external clock input 32.768 kHz (Typ.)			
OSC3 Oscillation circuit	Crystal oscillation circuit/ceramic oscillation circuit/CR oscillation circuit/external clock input 8.2 MHz (Max.)			
Instruction set	608 types (Usable for multiplication and division instructions)			
Min. instruction execution time	0.244 μsec/8.2 MHz (2 clock)			
Internal ROM capacity	48K bytes	16K bytes		8K bytes
Internal RAM capacity	2K byte/RAM 3,216 bits/display memory			256 bytes/RAM 3,216 bits/display memory
Bus line	Address bus: 19 bits (Also usable as a general output port when not used as a bus) Data bus: 8 bits (Also usable as a general I/O port when not used as a bus) $\overline{CE}$ signal: 4 bits $\overline{WR}$ signal: 1 bit $\overline{RD}$ signal: 1 bit (Also usable as a general output port when not used as a bus)			
Input port	10 bits (2 bits can be set for event counter clock input and bus request signal input terminal)			9 bits (1 bit can be set for event counter clock input)
Output port	9 bits (6 bits can be set for buzzer output, LCD control, FOUT, TOUT and bus acknowledge signal output terminal)			5 bits (5 bits can be set for buzzer, LCD control, FOUT and TOUT)
I/O port	8 bits (4 bits each can be set for serial interface input/output and analog comparator input)			
Serial interface	1ch (Optional clock synchronous system or asynchronous system)			
Timer	Programmable timer (8 bits): 2ch (1ch can be set as an event counter or 2ch as a 16 bits programmable timer for 1ch) Clock timer (8 bits): 1ch Stopwatch timer (8 bits): 1ch			
Power supply circuit to drive liquid crystals	Built-in (booster type, 5 potentials)			
LCD driver	Dot matrix type (5 × 8 or 5 × 5 fonts) 51 SEG × 32 COM 67 SEG × 16 COM 67 SEG × 8 COM Expandable external LCD driver			Dot matrix type (5 × 8 or 5 × 5 fonts) 41 SEG × 32 COM 57 SEG × 16 COM 57 SEG × 8 COM Expandable external LCD driver
Sound generator	Envelop function, equipped with volume control			
Watchdog timer	Built-in			
Analog comparator	2ch built-in			
Supply voltage detection (SVD) circuit	Can detect up to 16 different voltage levels			
Interrupt	External interrupt: Input interrupt 2 systems (3 types) Internal interrupt: Timer interrupt 3 systems (9 types) Serial interface interrupt 1 system (3 types)			
Supply voltage	Normal mode: 2.4 V–5.5 V (Max. 4.2 MHz) Low power mode: 1.8 V–3.5 V (Max. 50 kHz) High speed mode: 3.5 V–5.5 V (Max. 8.2 MHz)			
Current consumption	SLEEP status: 300 nA (Typ./normal mode) HALT status (32.768 kHz): 2 μA (Typ./normal mode) RUN status (32.768 kHz): 14 μA (Typ./normal mode) RUN status (4.9152 MHz): 2 mA (Typ./normal mode)			
Supply form	QFP8-160 pin, QFP17-160pin or chip		QFP8-160 pin or chip	

\* The number of bits cited for output ports and I/O ports does not include those shared with the bus.

### 1.3 Block Diagram

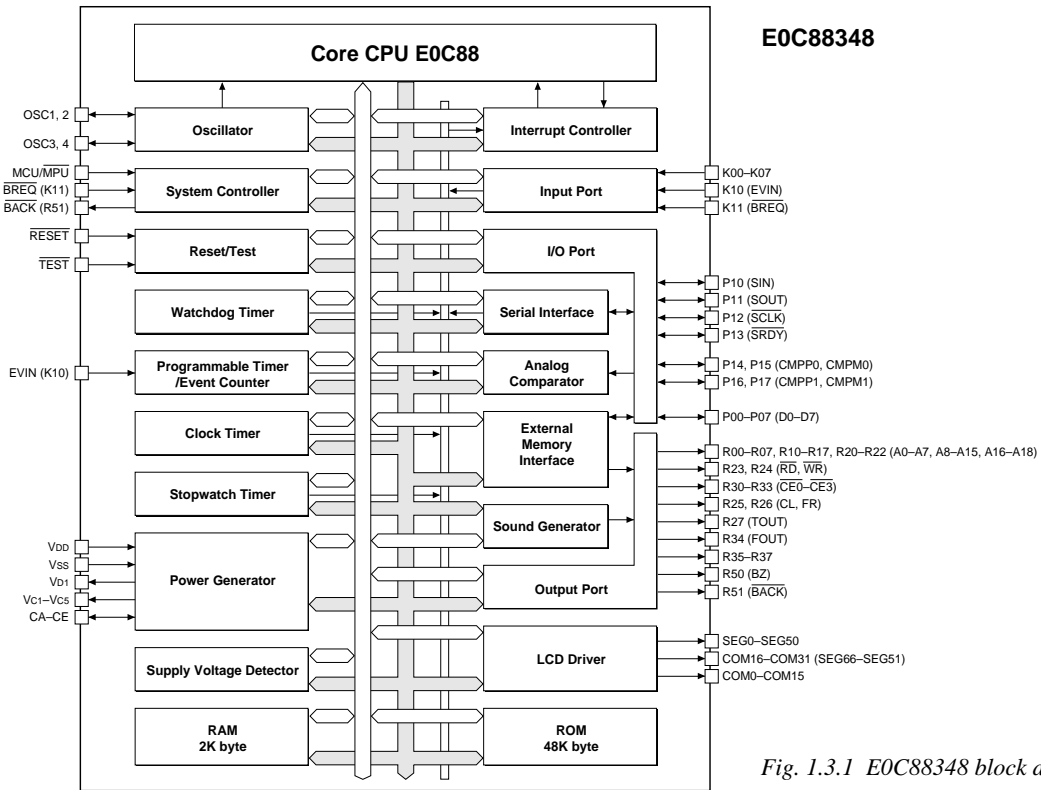

Fig. 1.3.1 E0C88348 block diagram

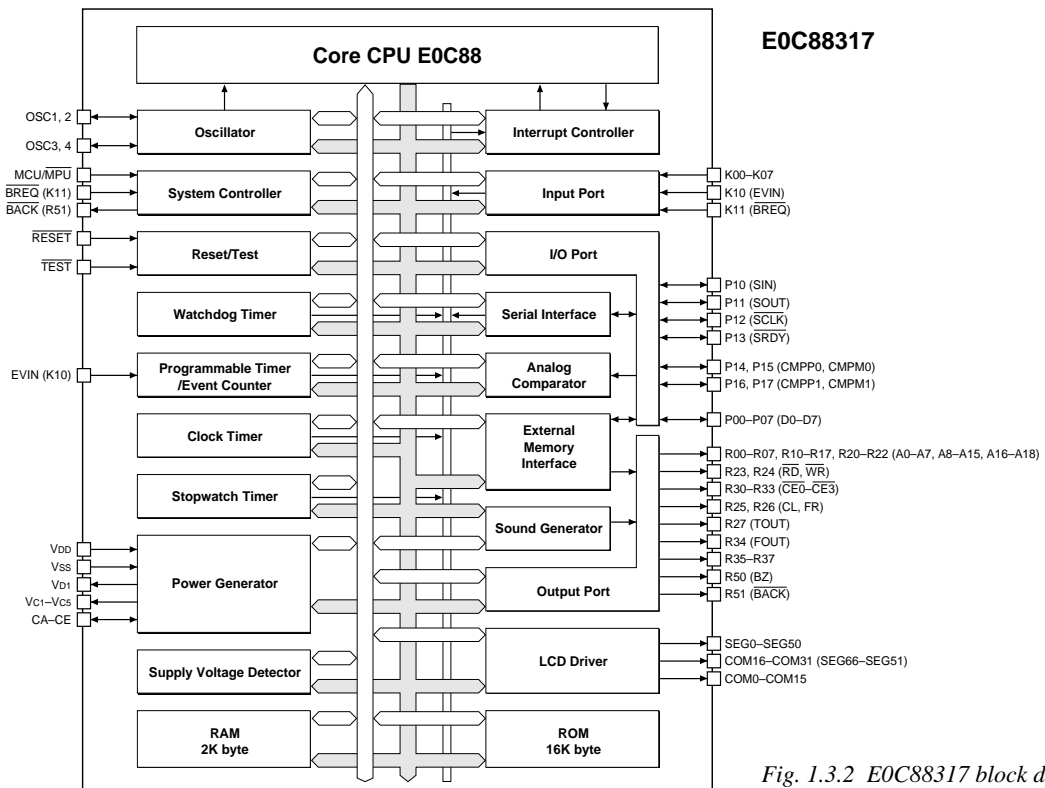

Fig. 1.3.2 E0C88317 block diagram

# 1 INTRODUCTION

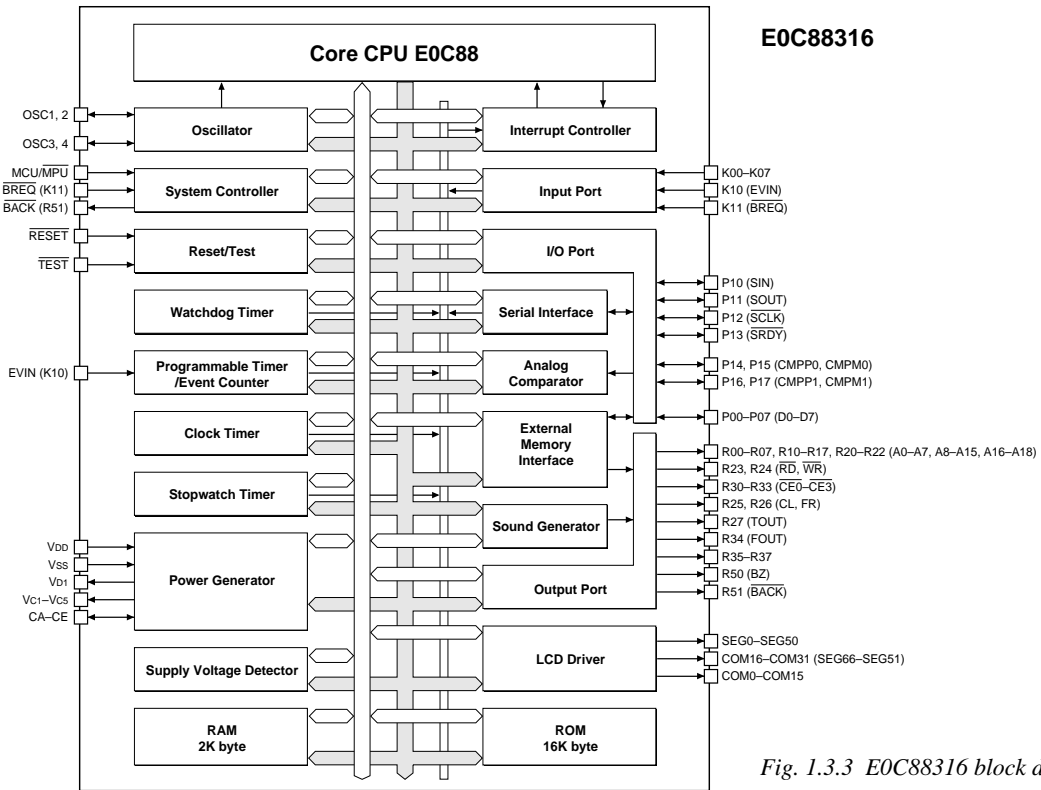

Fig. 1.3.3 E0C88316 block diagram

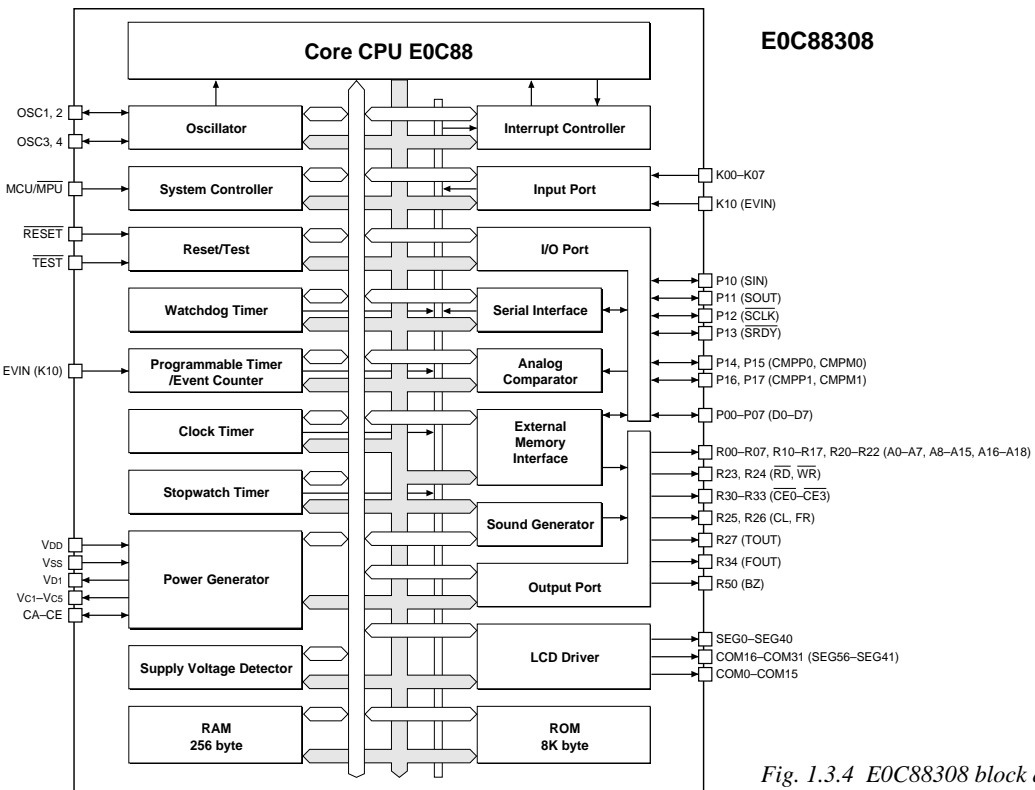
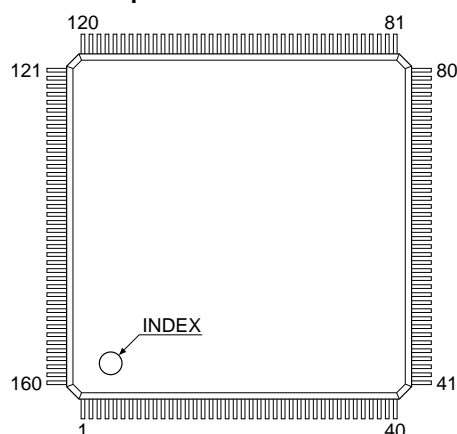

Fig. 1.3.4 E0C88308 block diagram

## 1.4 Pin Layout Diagram

### E0C88348

QFP8-160 pin



QFP17-160 pin

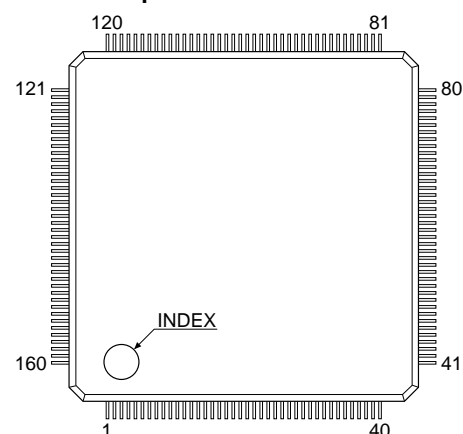

Pin No.	Pin name	Pin No.	Pin name	Pin No.	Pin name	Pin No.	Pin name
1	SEG18	41	COM24/SEG58	81	OSC1	121	R11/A9
2	SEG19	42	COM23/SEG59	82	OSC2	122	R12/A10
3	SEG20	43	COM22/SEG60	83	$\overline{\text{TEST}}$	123	R13/A11
4	SEG21	44	COM21/SEG61	84	$\overline{\text{RESET}}$	124	R14/A12
5	SEG22	45	COM20/SEG62	85	MCU/MPU	125	R15/A13
6	SEG23	46	COM19/SEG63	86	K11/BREQ	126	R16/A14
7	SEG24	47	COM18/SEG64	87	K10/EVIN	127	R17/A15
8	SEG25	48	COM17/SEG65	88	K07	128	R20/A16
9	SEG26	49	COM16/SEG66	89	K06	129	R21/A17
10	SEG27	50	COM15	90	K05	130	R22/A18
11	SEG28	51	COM14	91	K04	131	R23/RD
12	SEG29	52	COM13	92	K03	132	R24/WR
13	SEG30	53	COM12	93	K02	133	R25/CL
14	SEG31	54	COM11	94	K01	134	R26/FR
15	SEG32	55	COM10	95	K00	135	R27/TOUT
16	SEG33	56	COM9	96	P17/CMPP1	136	R30/CE0
17	SEG34	57	COM8	97	P16/CMPP1	137	R31/CE1
18	SEG35	58	COM7	98	P15/CMPP0	138	R32/CE2
19	SEG36	59	COM6	99	P14/CMPP0	139	R33/CE3
20	SEG37	60	COM5	100	P13/SRDY	140	R34/FOUT
21	SEG38	61	COM4	101	P12/SCLK	141	R50/BZ
22	SEG39	62	COM3	102	P11/SOUT	142	R51/BACK
23	SEG40	63	COM2	103	P10/SIN	143	SEG0
24	SEG41	64	COM1	104	P07/D7	144	SEG1
25	SEG42	65	COM0	105	P06/D6	145	SEG2
26	SEG43	66	CE	106	P05/D5	146	SEG3
27	SEG44	67	CD	107	P04/D4	147	SEG4
28	SEG45	68	CC	108	P03/D3	148	SEG5
29	SEG46	69	CB	109	P02/D2	149	SEG6
30	SEG47	70	CA	110	P01/D1	150	SEG7
31	SEG48	71	Vc5	111	P00/D0	151	SEG8
32	SEG49	72	Vc4	112	R00/A0	152	SEG9
33	SEG50	73	Vc3	113	R01/A1	153	SEG10
34	COM31/SEG51	74	Vc2	114	R02/A2	154	SEG11
35	COM30/SEG52	75	Vc1	115	R03/A3	155	SEG12
36	COM29/SEG53	76	OSC3	116	R04/A4	156	SEG13
37	COM28/SEG54	77	OSC4	117	R05/A5	157	SEG14
38	COM27/SEG55	78	Vd1	118	R06/A6	158	SEG15
39	COM26/SEG56	79	Vdd	119	R07/A7	159	SEG16
40	COM25/SEG57	80	Vss	120	R10/A8	160	SEG17

Fig. 1.4.1 E0C88348 pin layout

## 1 INTRODUCTION

Table 1.4.1 E0C88348 pin description

Pin name	Pin No.	In/out	Function
V <sub>DD</sub>	79	–	Power supply (+) terminal
V <sub>SS</sub>	80	–	Power supply (GND) terminal
V <sub>DI</sub>	78	–	Regulated voltage output terminal for oscillators
V <sub>C1</sub> –V <sub>C5</sub>	75–71	O	LCD drive voltage output terminals
CA–CE	70–66	–	Booster capacitor connection terminals for LCD
OSC1	81	I	OSC1 oscillation input terminal (select crystal oscillation/CR oscillation/external clock input with mask option)
OSC2	82	O	OSC1 oscillation output terminal
OSC3	76	I	OSC3 oscillation input terminal (select crystal/ceramic/CR oscillation/external clock input with mask option)
OSC4	77	O	OSC3 oscillation output terminal
MCU/MPU	85	I	Terminal for setting MCU or MPU modes
K00–K07	95–88	I	Input terminals (K00–K07)
K10/EVIN	87	I	Input terminal (K10) or event counter external clock input terminal (EVIN)
K11/BREQ	86	I	Input terminal (K11) or bus request signal input terminal (BREQ)
R00–R07/A0–A7	112–119	O	Output terminals (R00–R07) or address bus (A0–A7)
R10–R17/A8–A15	120–127	O	Output terminals (R10–R17) or address bus (A8–A15)
R20–R22/A16–A18	128–130	O	Output terminals (R20–R22) or address bus (A16–A18)
R23/RD	131	O	Output terminal (R23) or read signal output terminal (RD)
R24/WR	132	O	Output terminal (R24) or write signal output terminal (WR)
R25/CL	133	O	Output terminal (R25) or LCD synchronous signal output terminal (CL)
R26/FR	134	O	Output terminal (R26) or LCD frame signal output terminal (FR)
R27/TOUT	135	O	Output terminal (R27) or programmable timer underflow signal output terminal (TOUT)
R30–R33/CE0–CE3	136–139	O	Output terminals (R30–R33) or chip enable output terminals (CE0–CE3)
R34/FOUT	140	O	Output terminal (R34) or clock output terminal (FOUT)
R35–R37 *2		O	Output terminals (R35–R37)
R50/BZ	141	O	Output terminal (R50) or buzzer output terminal (BZ)
R51/BACK	142	O	Output terminal (R51) or bus acknowledge signal output terminal (BACK)
P00–P07/D0–D7	111–104	I/O	I/O terminals (P00–P07) or data bus (D0–D7)
P10/SIN	103	I/O	I/O terminal (P10) or serial I/F data input terminal (SIN)
P11/SOUT	102	I/O	I/O terminal (P11) or serial I/F data output terminal (SOUT)
P12/SCLK	101	I/O	I/O terminal (P12) or serial I/F clock I/O terminal (SCLK)
P13/SRDY	100	I/O	I/O terminal (P13) or serial I/F ready signal output terminal (SRDY)
P14/CMPP0	99	I/O	I/O terminal (P14) or comparator 0 non-inverted input terminal
P15/CMPP0	98	I/O	I/O terminal (P15) or comparator 0 inverted input terminal
P16/CMPP1	97	I/O	I/O terminal (P16) or comparator 1 non-inverted input terminal
P17/CMPP1	96	I/O	I/O terminal (P17) or comparator 1 inverted input terminal
COM0–COM15	65–50	O	LCD common output terminals
COM16–COM31 /SEG66–SEG51	49–34	O	LCD common output terminals (when 1/32 duty is selected) or LCD segment output terminal (when 1/16 or 1/8 duty is selected)
SEG0–SEG50	143–160, 1–33	O	LCD segment output terminals
RESET	84	I	Initial reset input terminal
TEST *1	83	I	Test input terminal

\*1 TEST is the terminal used for shipping inspection of the IC. For normal operation be sure it is connected to V<sub>DD</sub>.

\*2 R35–R37 terminals can be used only when chip is being shipped.

## E0C88317

QFP8-160 pin

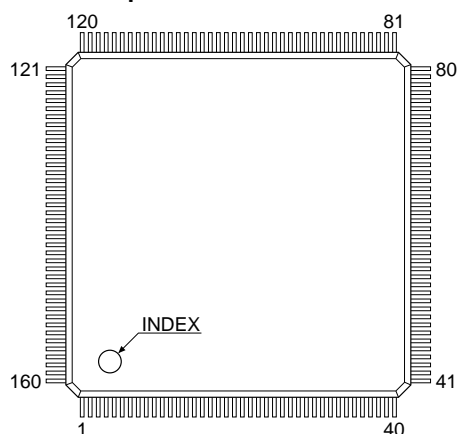

QFP17-160 pin

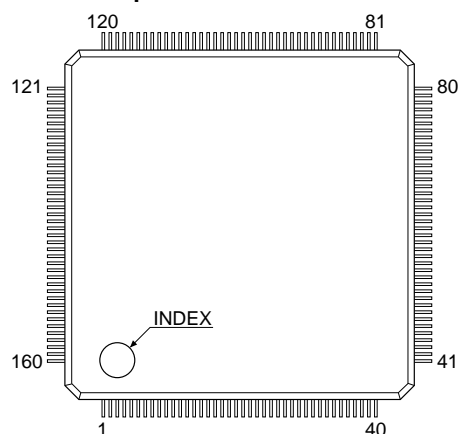

Pin No.	Pin name	Pin No.	Pin name	Pin No.	Pin name	Pin No.	Pin name
1	SEG18	41	COM24/SEG58	81	OSC1	121	R11/A9
2	SEG19	42	COM23/SEG59	82	OSC2	122	R12/A10
3	SEG20	43	COM22/SEG60	83	TEST	123	R13/A11
4	SEG21	44	COM21/SEG61	84	RESET	124	R14/A12
5	SEG22	45	COM20/SEG62	85	MCU/MPU	125	R15/A13
6	SEG23	46	COM19/SEG63	86	K11/BREQ	126	R16/A14
7	SEG24	47	COM18/SEG64	87	K10/EVIN	127	R17/A15
8	SEG25	48	COM17/SEG65	88	K07	128	R20/A16
9	SEG26	49	COM16/SEG66	89	K06	129	R21/A17
10	SEG27	50	COM15	90	K05	130	R22/A18
11	SEG28	51	COM14	91	K04	131	R23/RD
12	SEG29	52	COM13	92	K03	132	R24/WR
13	SEG30	53	COM12	93	K02	133	R25/CL
14	SEG31	54	COM11	94	K01	134	R26/FR
15	SEG32	55	COM10	95	K00	135	R27/TOUT
16	SEG33	56	COM9	96	P17/CMPM1	136	R30/CE0
17	SEG34	57	COM8	97	P16/CMPP1	137	R31/CE1
18	SEG35	58	COM7	98	P15/CMPM0	138	R32/CE2
19	SEG36	59	COM6	99	P14/CMPP0	139	R33/CE3
20	SEG37	60	COM5	100	P13/SRDY	140	R34/FOUT
21	SEG38	61	COM4	101	P12/SCLK	141	R50/BZ
22	SEG39	62	COM3	102	P11/SOUT	142	R51/BACK
23	SEG40	63	COM2	103	P10/SIN	143	SEG0
24	SEG41	64	COM1	104	P07/D7	144	SEG1
25	SEG42	65	COM0	105	P06/D6	145	SEG2
26	SEG43	66	CE	106	P05/D5	146	SEG3
27	SEG44	67	CD	107	P04/D4	147	SEG4
28	SEG45	68	CC	108	P03/D3	148	SEG5
29	SEG46	69	CB	109	P02/D2	149	SEG6
30	SEG47	70	CA	110	P01/D1	150	SEG7
31	SEG48	71	Vc5	111	P00/D0	151	SEG8
32	SEG49	72	Vc4	112	R00/A0	152	SEG9
33	SEG50	73	Vc3	113	R01/A1	153	SEG10
34	COM31/SEG51	74	Vc2	114	R02/A2	154	SEG11
35	COM30/SEG52	75	Vc1	115	R03/A3	155	SEG12
36	COM29/SEG53	76	OSC3	116	R04/A4	156	SEG13
37	COM28/SEG54	77	OSC4	117	R05/A5	157	SEG14
38	COM27/SEG55	78	Vd1	118	R06/A6	158	SEG15
39	COM26/SEG56	79	VDD	119	R07/A7	159	SEG16
40	COM25/SEG57	80	VSS	120	R10/A8	160	SEG17

Fig. 1.4.2 E0C88317 pin layout

## 1 INTRODUCTION

Table 1.4.2 E0C88317 pin description

Pin name	Pin No.	In/out	Function
VDD	79	–	Power supply (+) terminal
VSS	80	–	Power supply (GND) terminal
V <sub>D1</sub>	78	–	Regulated voltage output terminal for oscillators
V <sub>C1</sub> –V <sub>C5</sub>	75–71	O	LCD drive voltage output terminals
CA–CE	70–66	–	Booster capacitor connection terminals for LCD
OSC1	81	I	OSC1 oscillation input terminal (select crystal oscillation/CR oscillation/external clock input with mask option)
OSC2	82	O	OSC1 oscillation output terminal
OSC3	76	I	OSC3 oscillation input terminal (select crystal/ceramic/CR oscillation/external clock input with mask option)
OSC4	77	O	OSC3 oscillation output terminal
MCU/MPU	85	I	Terminal for setting MCU or MPU modes
K00–K07	95–88	I	Input terminals (K00–K07)
K10/EVIN	87	I	Input terminal (K10) or event counter external clock input terminal (EVIN)
K11/BREQ	86	I	Input terminal (K11) or bus request signal input terminal (BREQ)
R00–R07/A0–A7	112–119	O	Output terminals (R00–R07) or address bus (A0–A7)
R10–R17/A8–A15	120–127	O	Output terminals (R10–R17) or address bus (A8–A15)
R20–R22/A16–A18	128–130	O	Output terminals (R20–R22) or address bus (A16–A18)
R23/RD	131	O	Output terminal (R23) or read signal output terminal (RD)
R24/WR	132	O	Output terminal (R24) or write signal output terminal (WR)
R25/CL	133	O	Output terminal (R25) or LCD synchronous signal output terminal (CL)
R26/FR	134	O	Output terminal (R26) or LCD frame signal output terminal (FR)
R27/TOUT	135	O	Output terminal (R27) or programmable timer underflow signal output terminal (TOUT)
R30–R33/CE0–CE3	136–139	O	Output terminals (R30–R33) or chip enable output terminals (CE0–CE3)
R34/FOUT	140	O	Output terminal (R34) or clock output terminal (FOUT)
R35–R37 *2		O	Output terminals (R35–R37)
R50/BZ	141	O	Output terminal (R50) or buzzer output terminal (BZ)
R51/BACK	142	O	Output terminal (R51) or bus acknowledge signal output terminal (BACK)
P00–P07/D0–D7	111–104	I/O	I/O terminals (P00–P07) or data bus (D0–D7)
P10/SIN	103	I/O	I/O terminal (P10) or serial I/F data input terminal (SIN)
P11/SOUT	102	I/O	I/O terminal (P11) or serial I/F data output terminal (SOUT)
P12/SCLK	101	I/O	I/O terminal (P12) or serial I/F clock I/O terminal (SCLK)
P13/SRDY	100	I/O	I/O terminal (P13) or serial I/F ready signal output terminal (SRDY)
P14/CMPPO	99	I/O	I/O terminal (P14) or comparator 0 non-inverted input terminal
P15/CMPM0	98	I/O	I/O terminal (P15) or comparator 0 inverted input terminal
P16/CMPPI	97	I/O	I/O terminal (P16) or comparator 1 non-inverted input terminal
P17/CMPM1	96	I/O	I/O terminal (P17) or comparator 1 inverted input terminal
COM0–COM15	65–50	O	LCD common output terminals
COM16–COM31 /SEG66–SEG51	49–34	O	LCD common output terminals (when 1/32 duty is selected) or LCD segment output terminal (when 1/16 or 1/8 duty is selected)
SEG0–SEG50	143–160, 1–33	O	LCD segment output terminals
RESET	84	I	Initial reset input terminal
TEST *1	83	I	Test input terminal

\*1 TEST is the terminal used for shipping inspection of the IC. For normal operation be sure it is connected to VDD.

\*2 R35–R37 terminals can be used only when chip is being shipped.



# E0C88316

## QFP8-160 pin

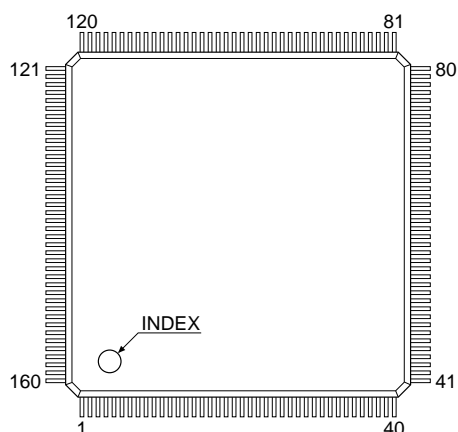

Pin No.	Pin name	Pin No.	Pin name	Pin No.	Pin name	Pin No.	Pin name
1	SEG18	41	COM24/SEG58	81	OSC1	121	R11/A9
2	SEG19	42	COM23/SEG59	82	OSC2	122	R12/A10
3	SEG20	43	COM22/SEG60	83	$\overline{\text{TEST}}$	123	R13/A11
4	SEG21	44	COM21/SEG61	84	$\overline{\text{RESET}}$	124	R14/A12
5	SEG22	45	COM20/SEG62	85	$\overline{\text{MCU/MPU}}$	125	R15/A13
6	SEG23	46	COM19/SEG63	86	K11/BREQ	126	R16/A14
7	SEG24	47	COM18/SEG64	87	K10/EVIN	127	R17/A15
8	SEG25	48	COM17/SEG65	88	K07	128	R20/A16
9	SEG26	49	COM16/SEG66	89	K06	129	R21/A17
10	SEG27	50	COM15	90	K05	130	R22/A18
11	SEG28	51	COM14	91	K04	131	R23/RD
12	SEG29	52	COM13	92	K03	132	R24/WR
13	SEG30	53	COM12	93	K02	133	R25/CL
14	SEG31	54	COM11	94	K01	134	R26/FR
15	SEG32	55	COM10	95	K00	135	R27/TOUT
16	SEG33	56	COM9	96	P17/CMPM1	136	R30/CE0
17	SEG34	57	COM8	97	P16/CMPP1	137	R31/CE1
18	SEG35	58	COM7	98	P15/CMPM0	138	R32/CE2
19	SEG36	59	COM6	99	P14/CMPP0	139	R33/CE3
20	SEG37	60	COM5	100	P13/SRDY	140	R34/FOUT
21	SEG38	61	COM4	101	P12/SCLK	141	R50/BZ
22	SEG39	62	COM3	102	P11/SOUT	142	R51/BACK
23	SEG40	63	COM2	103	P10/SIN	143	SEG0
24	SEG41	64	COM1	104	P07/D7	144	SEG1
25	SEG42	65	COM0	105	P06/D6	145	SEG2
26	SEG43	66	CE	106	P05/D5	146	SEG3
27	SEG44	67	CD	107	P04/D4	147	SEG4
28	SEG45	68	CC	108	P03/D3	148	SEG5
29	SEG46	69	CB	109	P02/D2	149	SEG6
30	SEG47	70	CA	110	P01/D1	150	SEG7
31	SEG48	71	Vc5	111	P00/D0	151	SEG8
32	SEG49	72	Vc4	112	R00/A0	152	SEG9
33	SEG50	73	Vc3	113	R01/A1	153	SEG10
34	COM31/SEG51	74	Vc2	114	R02/A2	154	SEG11
35	COM30/SEG52	75	Vc1	115	R03/A3	155	SEG12
36	COM29/SEG53	76	OSC3	116	R04/A4	156	SEG13
37	COM28/SEG54	77	OSC4	117	R05/A5	157	SEG14
38	COM27/SEG55	78	Vd1	118	R06/A6	158	SEG15
39	COM26/SEG56	79	Vdd	119	R07/A7	159	SEG16
40	COM25/SEG57	80	Vss	120	R10/A8	160	SEG17

Fig. 1.4.3 E0C88316 pin layout

# 1 INTRODUCTION

Table 1.4.3 E0C88316 pin description

Pin name	Pin No.	In/out	Function
V <sub>DD</sub>	79	–	Power supply (+) terminal
V <sub>SS</sub>	80	–	Power supply (GND) terminal
V <sub>D1</sub>	78	–	Regulated voltage output terminal for oscillators
V <sub>C1</sub> –V <sub>C5</sub>	75–71	O	LCD drive voltage output terminals
CA–CE	70–66	–	Booster capacitor connection terminals for LCD
OSC1	81	I	OSC1 oscillation input terminal (select crystal oscillation/CR oscillation/external clock input with mask option)
OSC2	82	O	OSC1 oscillation output terminal
OSC3	76	I	OSC3 oscillation input terminal (select crystal/ceramic/CR oscillation/external clock input with mask option)
OSC4	77	O	OSC3 oscillation output terminal
MCU/MPU	85	I	Terminal for setting MCU or MPU modes
K00–K07	95–88	I	Input terminals (K00–K07)
K10/EVIN	87	I	Input terminal (K10) or event counter external clock input terminal (EVIN)
K11/BREQ	86	I	Input terminal (K11) or bus request signal input terminal (BREQ)
R00–R07/A0–A7	112–119	O	Output terminals (R00–R07) or address bus (A0–A7)
R10–R17/A8–A15	120–127	O	Output terminals (R10–R17) or address bus (A8–A15)
R20–R22/A16–A18	128–130	O	Output terminals (R20–R22) or address bus (A16–A18)
R23/RD	131	O	Output terminal (R23) or read signal output terminal (RD)
R24/WR	132	O	Output terminal (R24) or write signal output terminal (WR)
R25/CL	133	O	Output terminal (R25) or LCD synchronous signal output terminal (CL)
R26/FR	134	O	Output terminal (R26) or LCD frame signal output terminal (FR)
R27/TOUT	135	O	Output terminal (R27) or programmable timer underflow signal output terminal (TOUT)
R30–R33/CE0–CE3	136–139	O	Output terminals (R30–R33) or chip enable output terminals (CE0–CE3)
R34/FOUT	140	O	Output terminal (R34) or clock output terminal (FOUT)
R35–R37 *2		O	Output terminals (R35–R37)
R50/BZ	141	O	Output terminal (R50) or buzzer output terminal (BZ)
R51/BACK	142	O	Output terminal (R51) or bus acknowledge signal output terminal (BACK)
P00–P07/D0–D7	111–104	I/O	I/O terminals (P00–P07) or data bus (D0–D7)
P10/SIN	103	I/O	I/O terminal (P10) or serial I/F data input terminal (SIN)
P11/SOUT	102	I/O	I/O terminal (P11) or serial I/F data output terminal (SOUT)
P12/SCLK	101	I/O	I/O terminal (P12) or serial I/F clock I/O terminal (SCLK)
P13/SRDY	100	I/O	I/O terminal (P13) or serial I/F ready signal output terminal (SRDY)
P14/CMPP0	99	I/O	I/O terminal (P14) or comparator 0 non-inverted input terminal
P15/CMPM0	98	I/O	I/O terminal (P15) or comparator 0 inverted input terminal
P16/CMPP1	97	I/O	I/O terminal (P16) or comparator 1 non-inverted input terminal
P17/CMPM1	96	I/O	I/O terminal (P17) or comparator 1 inverted input terminal
COM0–COM15	65–50	O	LCD common output terminals
COM16–COM31 /SEG66–SEG51	49–34	O	LCD common output terminals (when 1/32 duty is selected) or LCD segment output terminal (when 1/16 or 1/8 duty is selected)
SEG0–SEG50	143–160, 1–33	O	LCD segment output terminals
RESET	84	I	Initial reset input terminal
TEST *1	83	I	Test input terminal

\*1 TEST is the terminal used for shipping inspection of the IC. For normal operation be sure it is connected to V<sub>DD</sub>.

\*2 R35–R37 terminals can be used only when chip is being shipped.

## E0C88308

### QFP8-160 pin

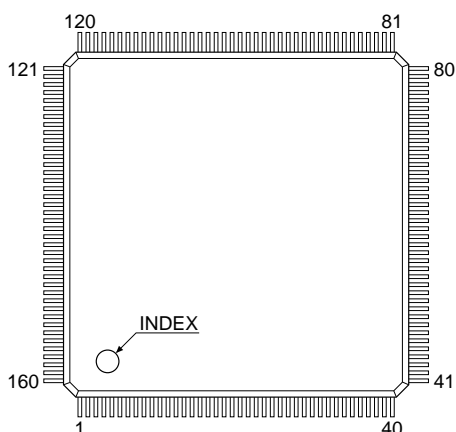

Pin No.	Pin name	Pin No.	Pin name	Pin No.	Pin name	Pin No.	Pin name
1	N.C.	41	N.C.	81	OSC1	121	N.C.
2	SEG13	42	COM22/SEG50	82	OSC2	122	R06/A6
3	SEG14	43	COM21/SEG51	83	$\overline{\text{TEST}}$	123	R07/A7
4	SEG15	44	COM20/SEG52	84	$\overline{\text{RESET}}$	124	R10/A8
5	SEG16	45	COM19/SEG53	85	MCU/MPU	125	R11/A9
6	SEG17	46	COM18/SEG54	86	N.C.	126	R12/A10
7	SEG18	47	COM17/SEG55	87	K10/EVIN	127	R13/A11
8	SEG19	48	COM16/SEG56	88	K07	128	R14/A12
9	SEG20	49	COM15	89	K06	129	R15/A13
10	SEG21	50	COM14	90	K05	130	R16/A14
11	SEG22	51	COM13	91	K04	131	R17/A15
12	SEG23	52	COM12	92	K03	132	R20/A16
13	SEG24	53	COM11	93	K02	133	R21/A17
14	SEG25	54	COM10	94	K01	134	R22/A18
15	SEG26	55	COM9	95	K00	135	R23/ $\overline{\text{RD}}$
16	SEG27	56	COM8	96	P17/CMPM1	136	R24/ $\overline{\text{WR}}$
17	SEG28	57	COM7	97	P16/CMPP1	137	R25/CL
18	SEG29	58	COM6	98	P15/CMPM0	138	R26/FR
19	SEG30	59	COM5	99	P14/CMPP0	139	R27/TOUT
20	SEG31	60	COM4	100	P13/ $\overline{\text{SRDY}}$	140	R30/ $\overline{\text{CE0}}$
21	N.C.	61	N.C.	101	P12/ $\overline{\text{SCLK}}$	141	N.C.
22	SEG32	62	COM3	102	P11/SOUT	142	R31/ $\overline{\text{CE1}}$
23	SEG33	63	COM2	103	P10/SIN	143	R32/ $\overline{\text{CE2}}$
24	SEG34	64	COM1	104	P07/D7	144	R33/ $\overline{\text{CE3}}$
25	SEG35	65	COM0	105	P06/D6	145	R34/FOUT
26	SEG36	66	CE	106	P05/D5	146	R50/BZ
27	SEG37	67	CD	107	P04/D4	147	SEG0
28	SEG38	68	CC	108	P03/D3	148	SEG1
29	SEG39	69	CB	109	P02/D2	149	SEG2
30	SEG40	70	CA	110	P01/D1	150	SEG3
31	COM31/SEG41	71	Vc5	111	P00/D0	151	SEG4
32	COM30/SEG42	72	Vc4	112	N.C.	152	SEG5
33	COM29/SEG43	73	Vc3	113	N.C.	153	SEG6
34	COM28/SEG44	74	Vc2	114	R00/A0	154	SEG7
35	COM27/SEG45	75	Vc1	115	R01/A1	155	SEG8
36	COM26/SEG46	76	OSC3	116	R02/A2	156	SEG9
37	COM25/SEG47	77	OSC4	117	R03/A3	157	SEG10
38	COM24/SEG48	78	Vd1	118	R04/A4	158	SEG11
39	COM23/SEG49	79	VDD	119	R05/A5	159	SEG12
40	N.C.	80	VSS	120	N.C.	160	N.C.

Fig. 1.4.4 E0C88308 pin layout

## 1 INTRODUCTION

Table 1.4.4 E0C88308 pin description

Pin name	Pin No.	In/out	Function
V <sub>DD</sub>	79	–	Power supply (+) terminal
V <sub>SS</sub>	80	–	Power supply (GND) terminal
V <sub>D1</sub>	78	–	Regulated voltage output terminal for oscillators
V <sub>C1</sub> –V <sub>C5</sub>	75–71	O	LCD drive voltage output terminals
CA–CE	70–66	–	Booster capacitor connection terminals for LCD
OSC1	81	I	OSC1 oscillation input terminal (select crystal oscillation/CR oscillation/external clock input with mask option)
OSC2	82	O	OSC1 oscillation output terminal
OSC3	76	I	OSC3 oscillation input terminal (select crystal/ceramic/CR oscillation/external clock input with mask option)
OSC4	77	O	OSC3 oscillation output terminal
MCU/MPU	85	I	Terminal for setting MCU or MPU modes
K00–K07	88–95	I	Input terminals (K00–K07)
K10/EVIN	87	I	Input terminal (K10) or event counter external clock input terminal (EVIN)
R00–R07/A0–A7	114–119, 122, 123	O	Output terminals (R00–R07) or address bus (A0–A7)
R10–R17/A8–A15	124–131	O	Output terminals (R10–R17) or address bus (A8–A15)
R20–R22/A16–A18	132–134	O	Output terminals (R20–R22) or address bus (A16–A18)
R23/RD	135	O	Output terminal (R23) or read signal output terminal (RD)
R24/WR	136	O	Output terminal (R24) or write signal output terminal (WR)
R25/CL	137	O	Output terminal (R25) or LCD synchronous signal output terminal (CL)
R26/FR	138	O	Output terminal (R26) or LCD frame signal output terminal (FR)
R27/TOUT	139	O	Output terminal (R27) or programmable timer underflow signal output terminal (TOUT)
R30–R33/CE0–CE3	140, 142–144	O	Output terminals (R30–R33) or chip enable output terminals (CE0–CE3)
R34/FOUT	145	O	Output terminal (R34) or clock output terminal (FOUT)
R50/BZ	146	O	Output terminal (R50) or buzzer output terminal (BZ)
P00–P07/D0–D7	104–111	I/O	I/O terminals (P00–P07) or data bus (D0–D7)
P10/SIN	103	I/O	I/O terminal (P10) or serial I/F data input terminal (SIN)
P11/SOUT	102	I/O	I/O terminal (P11) or serial I/F data output terminal (SOUT)
P12/SCLK	101	I/O	I/O terminal (P12) or serial I/F clock I/O terminal (SCLK)
P13/SRDY	100	I/O	I/O terminal (P13) or serial I/F ready signal output terminal (SRDY)
P14/CMPP0	99	I/O	I/O terminal (P14) or comparator 0 non-inverted input terminal
P15/CMPM0	98	I/O	I/O terminal (P15) or comparator 0 inverted input terminal
P16/CMPP1	97	I/O	I/O terminal (P16) or comparator 1 non-inverted input terminal
P17/CMPM1	96	I/O	I/O terminal (P17) or comparator 1 inverted input terminal
COM0–COM15	65–62, 60–49	O	LCD common output terminals
COM16–COM31 /SEG56–SEG41	48–42, 39–31	O	LCD common output terminals (when 1/32 duty is selected) or LCD segment output terminal (when 1/16 or 1/8 duty is selected)
SEG0–SEG40	147–159, 2–20, 22–30	O	LCD segment output terminals
RESET	84	I	Initial reset input terminal
TEST *	83	I	Test input terminal

\* TEST is the terminal used for shipping inspection of the IC. For normal operation be sure it is connected to V<sub>DD</sub>.

## 2 POWER SUPPLY

In this section, we will explain the operating voltage and the configuration of the internal power supply circuit of the E0C883xx.

### 2.1 Operating Voltage

The E0C883xx operating power voltage is as follows:

Normal mode:	2.4 V to 5.5 V
Low power mode:	1.8 V to 3.5 V
High speed mode:	3.5 V to 5.5 V

If supply voltage drops below level 0 (see Chapter 7, "ELECTRICAL CHARACTERISTICS"), the system is automatically reset by a supply voltage detection (SVD) circuit described in the latter. This function can be selected by mask option.

### 2.2 Internal Power Supply Circuit

The E0C883xx incorporate the power supply circuit shown in Figure 2.2.1. When voltage within the range described above is supplied to  $V_{DD}$  (+) and  $V_{SS}$  (GND), all the voltage needed for the internal circuit is generated internally in the IC.

Roughly speaking, the power supply circuit is divided into two sections.

One section is the oscillation system voltage regulator. The oscillation and internal circuits operate on the voltage  $V_{D1}$ , output by this circuit.  $V_{D1}$  voltage can be selected from among three types: 1.3 V (low-power mode), 2.2 V (normal mode) and 3.3 V (high-speed mode).

It should be selected by a program to switch according to the supply voltage and oscillation frequency.

See Section 5.4, "Oscillation Circuits and Operating Mode", for the switching of operating mode.

*Note: Under no circumstances should  $V_{D1}$  terminal output be used to drive external circuit.*

The second circuit section is the power supply circuit for the LCD system which generates the drive voltage for the LCD. Drive voltage has five potentials  $V_{C1}$ – $V_{C5}$  for 1/5 bias:  $V_{C1}$  and  $V_{C2}$  are generated by the LCD voltage regulator, and are boosted to generate  $V_{C3}$ – $V_{C5}$ . These five potentials are output externally at each of the terminals and can be used to supply an external expanded LCD driver.

See Chapter 7, "ELECTRICAL CHARACTERISTICS" for the voltage values.

In the E0C883xx, the LCD drive voltage is supplied to the built-in LCD driver which drives the LCD panel connected to the SEG and COM terminals.

*Note: Do not use terminals  $V_{C1}$ – $V_{C5}$  except to supply voltage to the expanded LCD driver. A load resistance between terminals  $V_{SS}$ – $V_{C1}$  is needed when driving an LCD panel that constitutes a heavy load.*

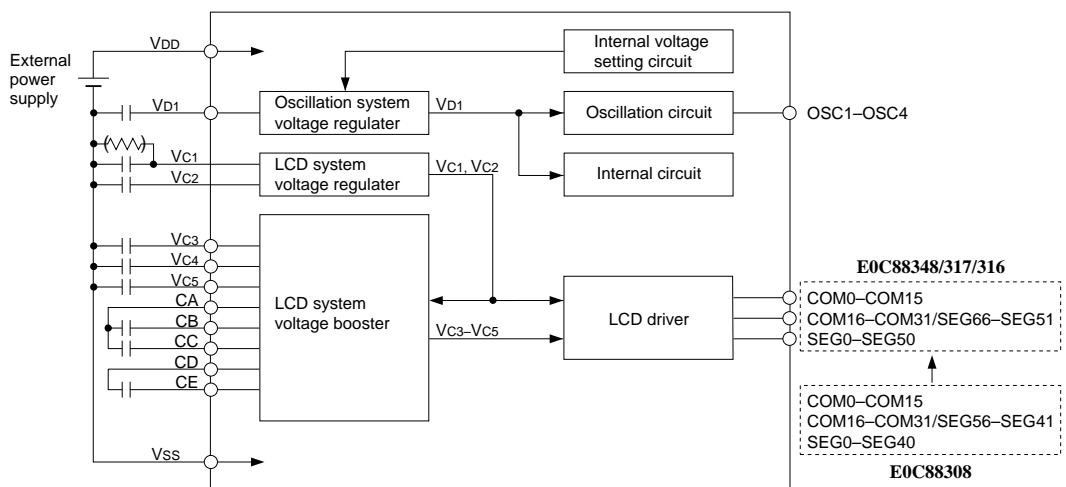

Fig. 2.2.1  
Configuration of  
power supply circuit

### 2.3 Heavy Load Protection Mode

The E0C883xx has a heavy load protection function for stable operation even when the supply voltage fluctuates by driving a heavy load. The heavy load protection mode becomes valid when the peripheral circuits are in the following status:

- (1) The OSC3 oscillation circuit is switched ON (OSCC = "1" and not in SLEEP)
- (2) The buzzer output is switched ON (BZON = "1" or BZSHT = "1")

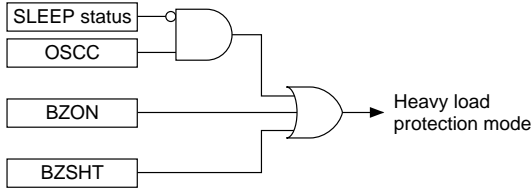

Fig. 2.3.1 Configuration of heavy load protection mode control circuit

For details of the OSC3 oscillation circuit and buzzer output, see "5.4 Oscillation Circuits and Operating Mode" and "5.13 Sound Generator", respectively.

# 3 CPU AND BUS CONFIGURATION

In this section, we will explain the CPU, operating mode and bus configuration.

## 3.1 CPU

The E0C883xx utilize the E0C88 8-bit core CPU whose resistor configuration, command set, etc. are virtually identical to other units in the family of processors incorporating the E0C88.

See the "E0C88 Core CPU Manual" for the E0C88.

Specifically, the E0C883xx employ the Model 3 E0C88 CPU which has a maximum address space of 512K bytes  $\times$  4.

## 3.2 Internal Memory

The E0C883xx is equipped with internal ROM and RAM as shown in Figure 3.2.1. Small scale applications can be handled by one chip. It is also possible to utilize internal memory in combination with external memory.

Furthermore, internal ROM can be disconnected from the bus and the resulting space released for external applications.

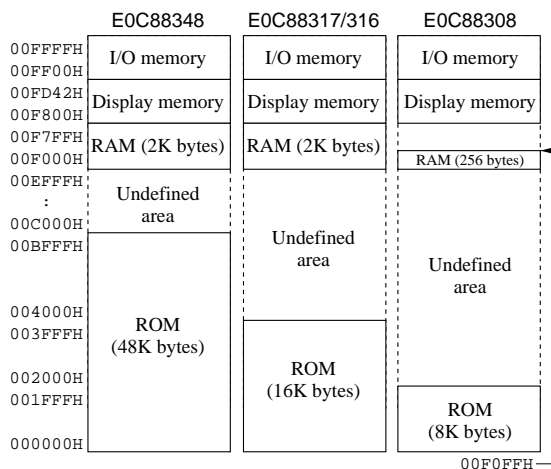

Fig. 3.2.1 Internal memory map

### 3.2.1 ROM

The internal ROM capacity is shown in Table 3.2.1.1.

Table 3.2.1.1 Internal ROM capacity

Model	ROM capacity	Address
<b>E0C88348</b>	48K bytes	000000H–00BFFFH
<b>E0C88317</b>	16K bytes	000000H–003FFFH
<b>E0C88316</b>	16K bytes	000000H–003FFFH
<b>E0C88308</b>	8K bytes	000000H–001FFFH

The ROM areas shown above can be released to external memory depending on the setting of the MCU/ $\overline{\text{MPU}}$  terminal. (See "3.5 Chip Mode".)

### 3.2.2 RAM

The internal RAM capacity is shown in Table 3.2.2.1.

Table 3.2.2.1 Internal RAM capacity

Model	RAM capacity	Address
<b>E0C88348</b>	2K bytes	00F000H–00F7FFH
<b>E0C88317</b>	2K bytes	00F000H–00F7FFH
<b>E0C88316</b>	2K bytes	00F000H–00F7FFH
<b>E0C88308</b>	256 bytes	00F000H–00F0FFFH

Even when external memory which overlaps the internal RAM area is expanded, the RAM area is not released to external memory. Access to this area is via internal RAM.

### 3.2.3 I/O memory

A memory mapped I/O method is employed in the E0C883xx for interfacing with internal peripheral circuit. Peripheral circuit control bits and data register are arranged in data memory space. Control and data exchange are conducted via normal memory access. I/O memory is arranged in page 0: 00FF00H–00FFFFH area.

See Section 5.1, "I/O Memory Map", for details of the I/O memory.

Even when external memory which overlaps the I/O memory area is expanded, the I/O memory area is not released to external memory. Access to this area is via I/O memory.

### 3.2.4 Display memory

The E0C883xx is equipped with an internal display memory which stores a display data for LCD driver.

Display memory is arranged in page 0: 00F<sub>x</sub>00H–00F<sub>x</sub>42H (x = 8–DH) in the data memory area. See Section 5.12, "LCD Controller", for details of the display memory. Like the I/O memory, display memory cannot be released to external memory.

### 3.3 Exception Processing Vectors

000000H–000023H in the program area of the E0C883xx is assigned as exception processing vectors. Furthermore, from 000026H to 0000FFH, software interrupt vectors are assignable to any two bytes which begin with an even address. Table 3.3.1 lists the vector addresses and the exception processing factors to which they correspond.

Table 3.3.1 Vector addresses and the corresponding exception processing factors

Vector address	Exception processing factor	Priority
000000H	Reset	High ↑
000002H	Zero division	
000004H	Watchdog timer (NMI)	
000006H	Programmable timer 1 interrupt	
000008H	Programmable timer 0 interrupt	
00000AH	K10, K11 input interrupt	
00000CH	K04–K07 input interrupt	
00000EH	K00–K03 input interrupt	
000010H	Serial I/F error interrupt	
000012H	Serial I/F receiving complete interrupt	
000014H	Serial I/F transmitting complete interrupt	
000016H	Stopwatch timer 100 Hz interrupt	
000018H	Stopwatch timer 10 Hz interrupt	
00001AH	Stopwatch timer 1 Hz interrupt	
00001CH	Clock timer 32 Hz interrupt	↓ Low
00001EH	Clock timer 8 Hz interrupt	
000020H	Clock timer 2 Hz interrupt	
000022H	Clock timer 1 Hz interrupt	
000024H	System reserved (cannot be used)	
000026H : 0000FEH	Software interrupt	

For each vector address and the address after it, the start address of the exception processing routine is written into the subordinate and super ordinate sequence. When an exception processing factor is generated, the exception processing routine is executed starting from the recorded address.

When multiple exception processing factors are generated at the same time, execution starts with the highest priority item.

The priority sequence shown in Table 3.3.1 assumes that the interrupt priority levels are all the same. The interrupt priority levels can be set by software in each system. (See Section 5.16 "Interrupt and Standby Status".)

*Note:* For exception processing other than reset, SC (system condition flag) and PC (program counter) are evacuated to the stack and branches to the exception processing routines. Consequently, when returning to the main routine from exception processing routines, please use the RETE instruction.

See the "E0C88 Core CPU Manual" for information on CPU operations when an exception processing factor is generated.

### 3.4 CC (Customized Condition Flag)

The E0C883xx does not use the customized condition flag (CC) in the core CPU. Accordingly, it cannot be used as a branching condition for the conditional branching instruction (JRS, CARS).



### 3.5 Chip Mode

#### 3.5.1 MCU mode and MPU mode

The chip operating mode can be set to one of two settings using the MCU/MPU terminal.

- MCU mode...Set the MCU/MPU terminal to HIGH**  
 Switch to this setting when using internal ROM. With respect to areas other than internal memory, external memory can even be expanded. See Section 3.5.2, "Bus mode", for the memory map.

In the MCU mode, during initial reset, only systems in internal memory are activated. Internal ROM is normally fixed as the top portion of the program memory common area (logical space 0000H–7FFFH). Exception processing vectors are assigned in internal ROM. Furthermore, the application initialization routines that start with reset exception processing must likewise be written to internal ROM. Since bus and other settings which correlate with external expanded memory can be executed in software, this processing is executed in the initialization routine written to internal ROM. Once these bus mode settings are made, external memory can be accessed.

When accessing internal memory in this mode, the chip enable ( $\overline{CE}$ ) and read ( $\overline{RD}$ )/write ( $\overline{WR}$ ) signals are not output to external memory, and the data bus (D0–D7) changed to high impedance status (pull-up status when the "pull-up resistors for P00–P07 enabled" have been selected by the mask option). Consequently, in cases where addresses overlap in external and internal memory, the areas in external memory will be unavailable.

- MPU mode...Set the MCU/MPU terminal to LOW**  
 Internal ROM area is released to an external device source. Internal ROM then becomes unusable and when this area is accessed, chip enable ( $\overline{CE}$ ) and read ( $\overline{RD}$ )/write ( $\overline{WR}$ ) signals are output to external memory and the data bus (D0–D7) become active. These signals are not output to an external source when other areas of internal memory are accessed.

In the MPU mode, the system is activated by external memory.

For this reason, in order to adjust bus settings to conform to the configuration of external memory during initial reset, the user can select the applicable system configuration using the mask option. (See "3.5.2 Bus mode")

When employing this mode, the exception processing vectors and initialization routine must be assigned within the common area (000000H–007FFFH).

You can select whether to use the built-in pull-up resistor of the MCU/MPU terminal by the mask option.

*Note: Setting of MCU/MPU terminal is latched at the rising edge of a reset signal input from the RESET terminal. Therefore, if the setting is to be changed, the RESET terminal must be set to LOW level once again.*

#### 3.5.2 Bus mode

In order to set bus specifications to match the configuration of external expanded memory, four different bus modes described below are selectable in software.

- Single chip mode**

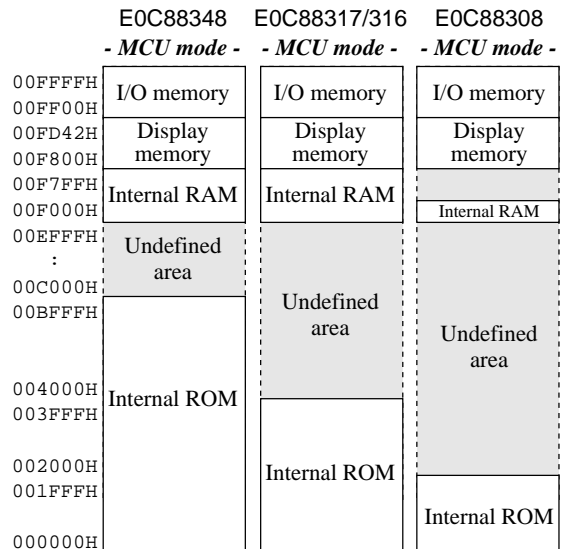

Fig. 3.5.2.1 Memory map for the single chip mode

The single chip mode setting applies when the E0C883xx is used as a single chip microcomputer without external expanded memory. Since this mode employs internal ROM, the system can only be operated in the MCU mode discussed in Section 3.5.1. In the MPU mode, the system cannot be set to the single chip mode.

### 3 CPU AND BUS CONFIGURATION

Since there is no need for an external bus line in this mode, terminals normally set for bus use can be used as general purpose output ports or I/O ports.

Accordingly, the output ports are in a 34-bit configuration in the E0C88348/317/316 and 30-bit in the E0C88308. The I/O ports are in a 16-bit configuration in both the models.

CPU operation in this mode is equivalent to the E0C88 core CPU Model 3 minimum mode.

Addresses assigned to internal memory within physical space 000000H to 00FFFFH are only effective as a target for accessing.

#### ■ Expanded 64K mode

The expanded 64K mode setting applies when the E0C883xx is used with 64K bytes or less of external expanded memory. In the E0C88316/308, this mode is usable regardless of the MCU/MPU mode setting. In the E0C88348/317, it can be used only in the MPU mode.

Because internal ROM is being used in the MCU mode, external memory in that area is not accessible.

External memory can be assigned to the area from 004000H to 00EFFFH in the E0C88348/317/316 and to the area from 002000H to 00EFFFH in the E0C88308.

Since the internal ROM area is released in the MPU mode, external memory can be assigned to the area from 000000H to 00EFFFH. The area from 00F000H to 00FFFFH is assigned to internal memory (RAM, etc.) and cannot be used to access an external device.

This mode setting is suitable for small- to mid-scale systems. The address range of the chip enable ( $\overline{CE}$ ) signal, adapted to memory chips with a capacity of from 8 to 64K bytes, can be selected in software to any one of four settings. See Section 3.6.4, "Chip enable ( $\overline{CE}$ ) signal", for the  $\overline{CE}$  signal.

CPU operation in this mode is equivalent to the E0C88 core CPU Model 3 minimum mode. The area within physical space 000000H to 00FFFFH is only effective as a target for accessing.

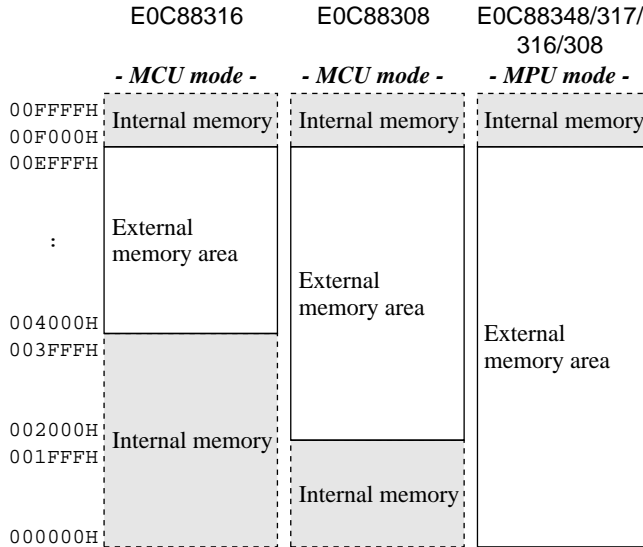

See Figure 3.2.1 for the internal memory

\* The E0C88348 and E0C88317 do not support the expanded 64K + MCU mode.

Fig. 3.5.2.2 Memory map for the expanded 64K mode

■ **Expanded 512K minimum mode**

The expanded 512K minimum mode setting applies when the E0C883xx is used with over 64K bytes and less than 512K bytes × 4 of external expanded memory. This mode is usable regardless of the MCU/MPU mode setting.

Because internal ROM is being used in the MCU mode, external memory can be assigned to the area from 080000H to 27FFFFH.

Since the internal ROM area is released in the MPU mode, external memory can be assigned to the area from 000000H to 1FFFFFFH. However, the area from 00F000H to 00FFFFH is assigned to internal memory and cannot be used to access an external device.

CPU operation in this mode is equivalent to the E0C88 core CPU Model3 minimum mode. The area within physical space 000000H to 1FFFFFFH in the MPU mode or physical space 080000H to 27FFFFH + internal memory in the MCU mode is effective as a target for accessing.

Furthermore, since program memory expansion is limited to less than 64K bytes configured with the common area (000000H to 007FFFFH) and one optional bank area (internal ROM + 32K in the MCU mode), this mode is suitable for small- to mid-scale program memory and large-scale data memory systems.

The address range of chip enable ( $\overline{CE}$ ) signals in this mode is fixed at 512K bytes.

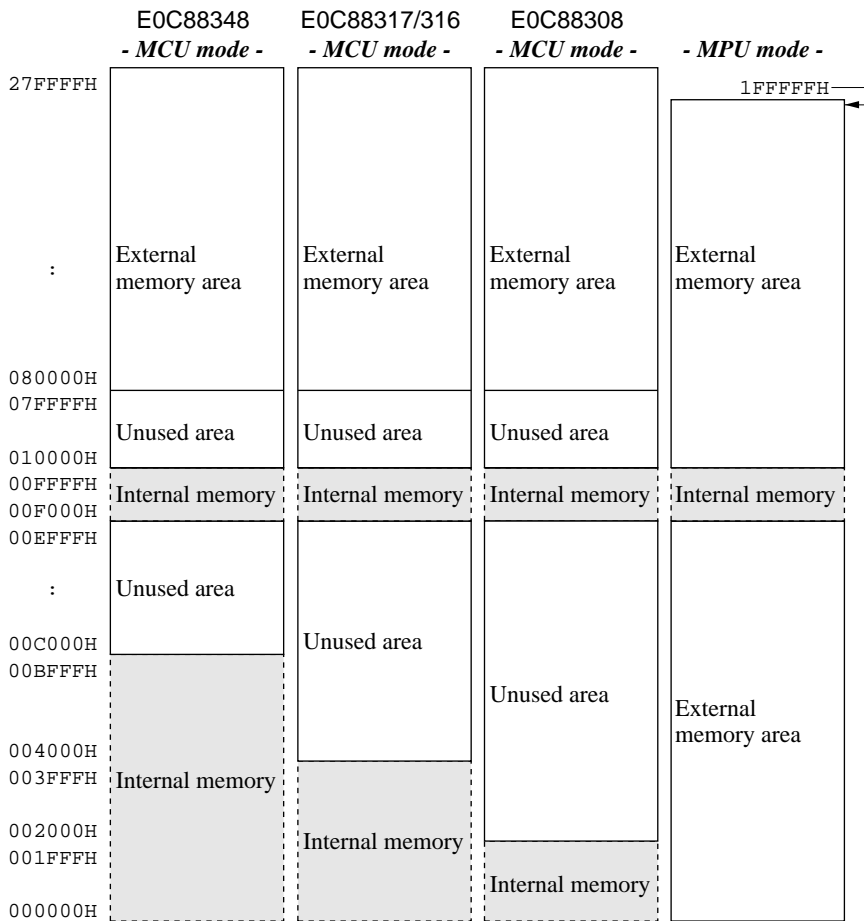

See Figure 3.2.1 for the internal memory

Fig. 3.5.2.3 Memory map for the expanded 512K minimum mode

■ **Expanded 512K maximum mode**

The expanded 512K maximum mode setting applies when the E0C883xx is used with over 64K bytes and less than 512K bytes × 4 of external expanded memory. This mode is usable regardless of the MCU/MPU mode setting.

Because internal ROM is being used in the MCU mode, external memory can be assigned to the area from 080000H to 27FFFFFFH.

Since the internal ROM area is released in the MPU mode, external memory can be assigned to the area from 000000H to 1FFFFFFH.

The area from 00F000H to 00FFFFH is assigned to internal memory and cannot be used to access an external device.

CPU operation in this mode is equivalent to the E0C88 core CPU Model 3 maximum mode, the area within physical space 000000H to 1FFFFFFH in the MPU mode or physical space 080000H to 27FFFFFFH + internal memory in the MCU mode is effective as a target for accessing. In the above mentioned physical space, since program memory and data memory can be secured with an optional (maximum 512K bytes × 4 program + data) size, this mode is suitable for systems with large-scale program and data capacity.

The address range of chip enable ( $\overline{CE}$ ) signals in this mode is fixed at 512K bytes.

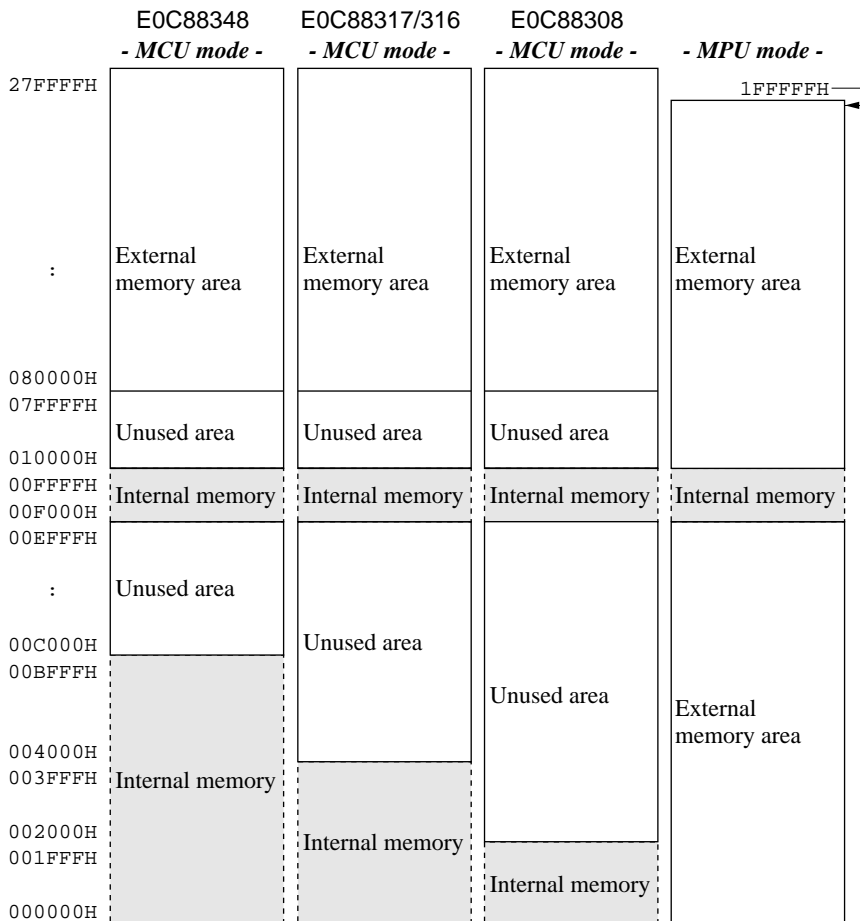

See Figure 3.2.1 for the internal memory

Fig. 3.5.2.4 Memory map for the expanded 512K maximum mode

There is an explanation on how all these settings are actually made in "5.2 System Controller and Bus Control" of this Manual.

### 3.6 External Bus

The E0C883xx has bus terminals that can address a maximum of 512K × 4 bytes and memory (and other) devices can be externally expanded according to the range of each bus mode described in the previous section.

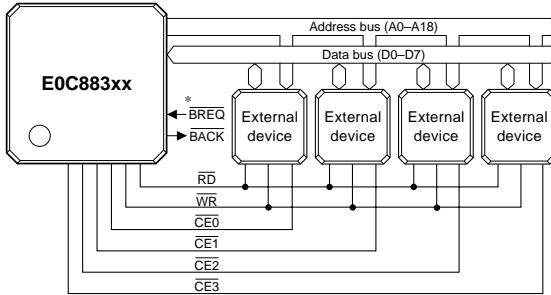

\* There is no bus authority release function in the E0C88308.

Fig. 3.6.1 External bus lines

Below is an explanation of external bus terminals. For information on control methods, see Section 5.2, "System Controller and Bus Control".

#### 3.6.1 Data bus

The E0C883xx possess an 8-bit external data bus (D0-D7). The terminals and I/O circuits of data bus D0-D7 are shared with I/O ports P00-P07, switching between these functions being determined by the bus mode setting.

In the single chip mode, the 8-bit terminals are all set as I/O ports P00-P07 and in the other expanded modes, they are set as data bus (D0-D7).

When set as data bus, the data register and I/O control register of each I/O port are detached from the I/O circuits and usable as a general purpose data register with read/write capabilities.

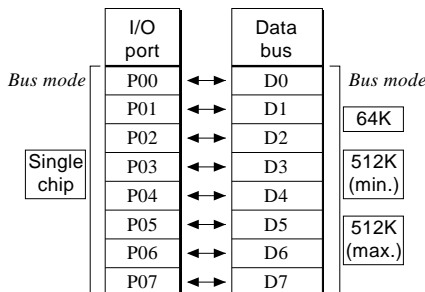

Fig. 3.6.1.1 Correspondence between data bus and I/O ports

With regard to the pull-up resistors that go ON only in input mode, the mask option can be used to select whether or not to use the pull-up resistor for each data bus line. (The same holds true when the terminals are used as I/O ports.)

#### 3.6.2 Address bus

The E0C883xx possess a 19-bit external address bus A0-A18. The terminals and output circuits of address bus A0-A18 are shared with output ports R00-R07 (=A0-A7), R10-R17 (=A8-A15) and R20-R22 (=A16-A18), switching between these functions being determined by the bus mode setting.

In the single chip mode, the 19-bit terminals are all set as output ports R00-R07, R10-R17 and R20-R22. In the expanded 64K mode, 16 of the 19-bit terminals, A0-A15, are set as the address bus, while the remaining 3 bits, A16-A18, are set as output ports R20-R22.

In the expanded 512K minimum and maximum modes, all of the 19-bit terminals are set as the address bus (A0-A18).

When set as an address bus, the data register and high impedance control register of each output port are detached from the output circuit and used as a general purpose data register with read/write capabilities.

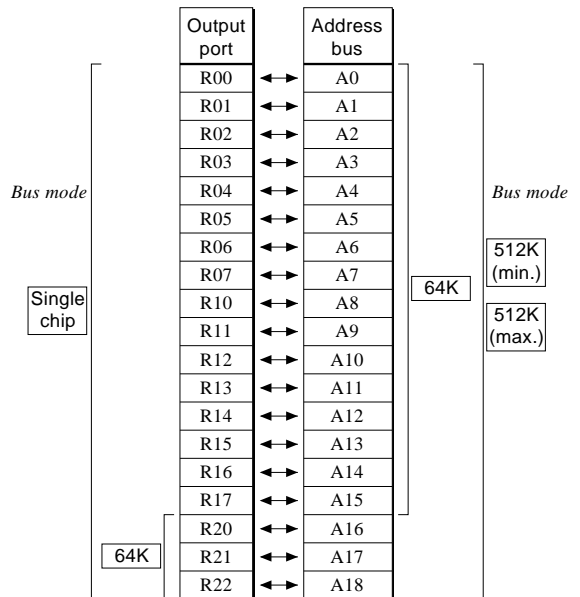

Fig. 3.6.2.1 Correspondence between address bus and output ports

### 3.6.3 Read ( $\overline{RD}$ )/write ( $\overline{WR}$ ) signals

The output terminals and output circuits for the read ( $\overline{RD}$ )/write ( $\overline{WR}$ ) signals directed to external devices are shared respectively with output ports R23 and R24, switching between these functions being determined by the bus mode setting. In the single chip mode, both of these terminals are set as output port terminals and in the other expanded modes, they are set as read ( $\overline{RD}$ )/write ( $\overline{WR}$ ) signal output terminals. When set as read ( $\overline{RD}$ )/write ( $\overline{WR}$ ) signal output terminal, the data register and high impedance control register for each output port (R23, R24) are detached from the output circuit and is usable as a general purpose data register with read/write capabilities.

These two signals are only output when the memory area of the external device is being accessed. They are not output when internal memory is accessed. See Section 3.6.5, "WAIT control", for the output timing of the signal.

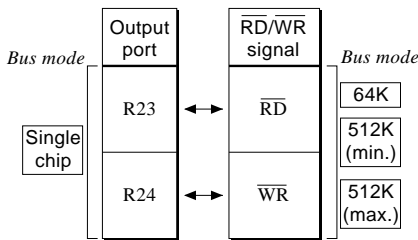

Fig. 3.6.3.1 Correspondence between read ( $\overline{RD}$ )/write ( $\overline{WR}$ ) signal and output ports

### 3.6.4 Chip enable ( $\overline{CE}$ ) signal

The E0C883xx is equipped with address decoders which can output four different chip enable ( $\overline{CE}$ ) signals.

Consequently, four devices equipped with a chip enable ( $\overline{CE}$ ) or chip select ( $\overline{CS}$ ) terminal can be directly connected without setting the address decoder to an external device.

The four chip enable ( $\overline{CE0}$ – $\overline{CE3}$ ) signal output terminals and output circuits are shared with output ports R30–R33 and in modes other than the single chip mode, the selection of chip enable ( $\overline{CE}$ ) or output port can be set in software for each of the four bits. When set for chip enable ( $\overline{CE}$ ) output, the data register and high impedance control register for each output port are detached from the output circuit and is usable as general purpose data register with read/write capabilities.

In the single chip mode, these terminals are set as output ports R30–R33.

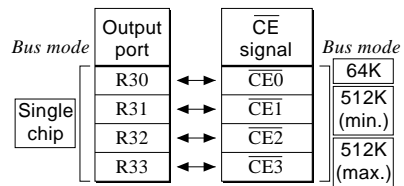

Fig. 3.6.4.1 Correspondence between  $\overline{CE}$  signals and output ports

The address range assigned to the four chip enable ( $\overline{CE}$ ) signals is determined by the bus mode setting. In the expanded 64K mode, the four different address ranges which match the amount of memory in use can be selected in software. Table 3.6.4.1 shows the address ranges which are assigned to the chip enable ( $\overline{CE}$ ) signal in each mode. When accessing the internal memory area, the  $\overline{CE}$  signal is not output. Care should be taken here because the address range for these portions of memory involves irregular settings. The arrangement of memory space for external devices does not necessarily have to be continuous from a subordinate address and any of the chip enable signals can be used to assign areas in memory.

Each of these signals is only output when the memory area of the external device is being accessed. They are not output when internal memory is accessed.

See Section 3.6.5, "WAIT control", for the output timing of signal.

Table 3.6.4.1  $\overline{CE0}$ – $\overline{CE3}$  address settings

(1) Expanded 64K mode + MCU mode (E0C88316)

$\overline{CE}$ signal	Address range (selected in software)			
	8K bytes	16K bytes	32K bytes	64K bytes
$\overline{CE0}$	008000H–009FFFH	–	004000H–007FFFH	004000H–00EFFFH
$\overline{CE1}$	00A000H–00BFFFH	004000H–007FFFH	008000H–00EFFFH	–
$\overline{CE2}$	004000H–005FFFH	008000H–00BFFFH	–	–
$\overline{CE3}$	006000H–007FFFH	00C000H–00EFFFH	–	–

(2) Expanded 64K mode + MCU mode (E0C88308)

$\overline{CE}$ signal	Address range (selected in software)			
	8K bytes	16K bytes	32K bytes	64K bytes
$\overline{CE0}$	008000H–009FFFH	002000H–003FFFH	002000H–007FFFH	002000H–00EFFFH
$\overline{CE1}$	002000H–003FFFH	004000H–007FFFH	008000H–00EFFFH	–
$\overline{CE2}$	004000H–005FFFH	008000H–00BFFFH	–	–
$\overline{CE3}$	006000H–007FFFH	00C000H–00EFFFH	–	–

(3) Expanded 64K mode + MPU mode (E0C88348/317/316/308)

$\overline{CE}$ signal	Address range (selected in software)			
	8K bytes	16K bytes	32K bytes	64K bytes
$\overline{CE0}$	000000H–001FFFH	000000H–003FFFH	000000H–007FFFH	000000H–00EFFFH
$\overline{CE1}$	002000H–003FFFH	004000H–007FFFH	008000H–00EFFFH	–
$\overline{CE2}$	004000H–005FFFH	008000H–00BFFFH	–	–
$\overline{CE3}$	006000H–007FFFH	00C000H–00EFFFH	–	–

(4) Expanded 512K minimum/maximum modes (E0C88348/317/316/308)

$\overline{CE}$ signal	Address range	
	MCU mode	MPU mode
$\overline{CE0}$	200000H–27FFFFH	000000H–00EFFFH, 010000H–07FFFFH
$\overline{CE1}$	080000H–0FFFFFFH	080000H–0FFFFFFH
$\overline{CE2}$	100000H–17FFFFH	100000H–17FFFFH
$\overline{CE3}$	180000H–1FFFFFFH	180000H–1FFFFFFH

### 3.6.5 WAIT control

In order to insure accessing of external low speed devices during high speed operations, the E0C883xx is equipped with a WAIT function which prolongs access time. (See the "E0C88 Core CPU Manual" for details of the WAIT function.)

The WAIT state numbers to be inserted can be selected in software from a series of 8 as shown in Table 3.6.5.1.

Table 3.6.5.1 Selectable WAIT state numbers

Selection No.	1	2	3	4	5	6	7	8
Insert states	0	2	4	6	8	10	12	14

\* One state is a 1/2 cycle of the clock in length.

The WAIT states set in software are inserted between bus cycle states T3–T4.

Note, however, that WAIT states cannot be inserted when an internal register and internal memory are being accessed and when operating with the OSC1 oscillation circuit (see "5.4 Oscillation Circuits and Operating Mode").

Consequently, WAIT state settings are meaningless in the single chip mode.

Figure 3.6.5.1 shows the memory read/write timing charts.

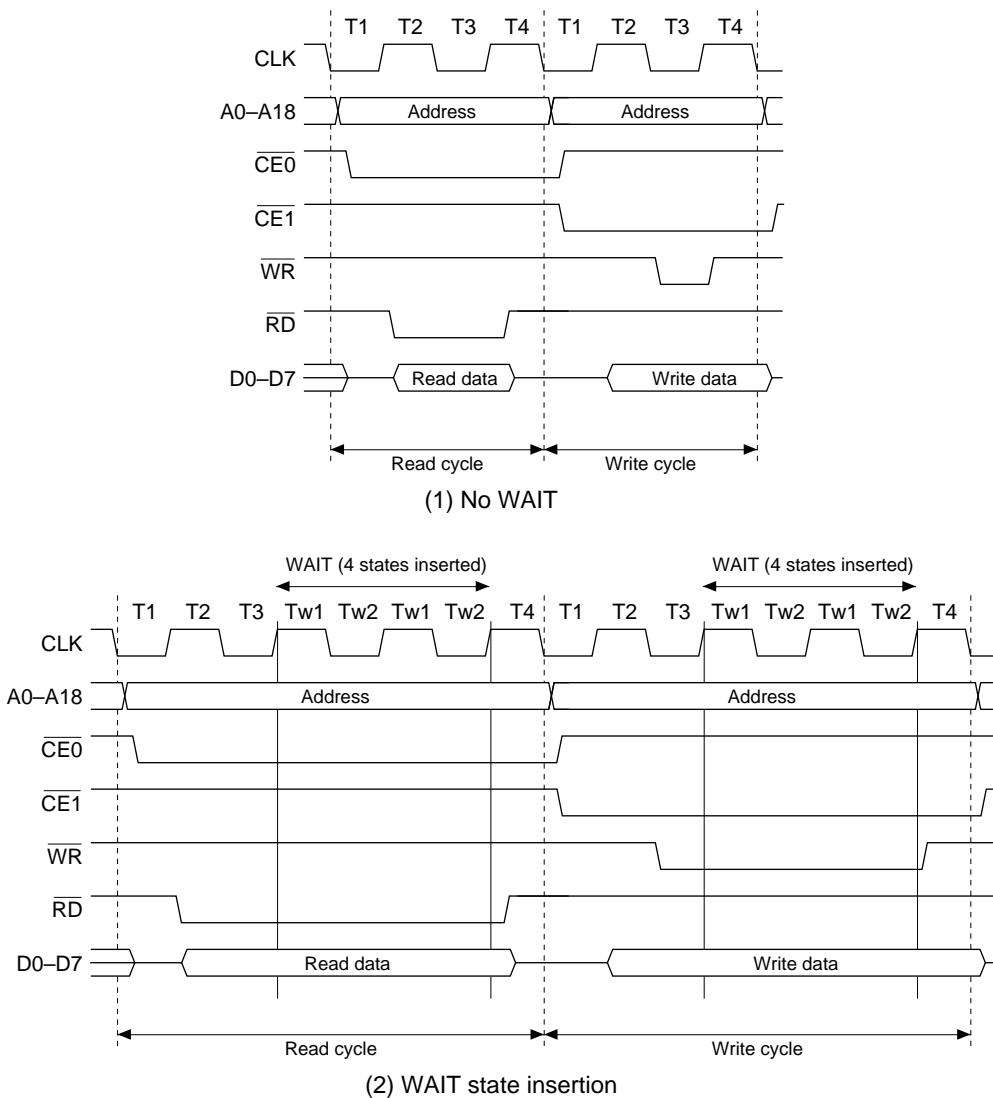

Fig. 3.6.5.1 Memory read/write cycle



### 3.6.6 Bus authority release state

The E0C88348/317/316 is equipped with a bus authority release function on request from an external device so that DMA (Direct Memory Access) transfer can be conducted between external devices. The internal memory cannot be accessed by this function.

There are two terminals used for this function: the bus authority release request signal ( $\overline{\text{BREQ}}$ ) input terminal and the bus authority release acknowledge signal ( $\overline{\text{BACK}}$ ) output terminal.

The  $\overline{\text{BREQ}}$  input terminal is shared with input port terminal K11 and the  $\overline{\text{BACK}}$  output terminal with output port terminal R51, use with setting to  $\overline{\text{BREQ}}/\overline{\text{BACK}}$  terminals done in software. In the single chip mode, or when using a system which does not require bus authority release, set respective terminals as input and output ports.

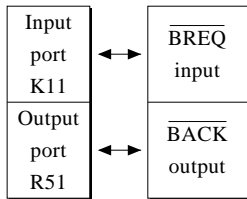

Fig. 3.6.6.1  $\overline{\text{BREQ}}/\overline{\text{BACK}}$  terminals

When the bus authority release request ( $\overline{\text{BREQ}} = \text{LOW}$ ) is received from an external device, the E0C883xx switches the address bus, data bus,  $\overline{\text{RD}}/\overline{\text{WR}}$  signal, and  $\overline{\text{CE}}$  signal lines to a high impedance state, outputs a LOW level from the  $\overline{\text{BACK}}$  terminal and releases bus authority.

As soon as a LOW level is output from the  $\overline{\text{BACK}}$  terminal, the external device can use the external bus. When DMA is completed, the external device returns the  $\overline{\text{BREQ}}$  terminal to HIGH and releases bus authority.

Figure 3.6.6.2 shows the bus authority release sequence.

During bus authority release state, internal memory cannot be accessed from the external device. In cases where external memory has areas which overlap areas in internal memory, the external memory areas can be accessed accordance with the  $\overline{\text{CE}}$  signal output by the external device.

*Note: Be careful with the system, such that an external device does not become the bus master, other than during the bus release status.*

*After setting the  $\overline{\text{BREQ}}$  terminal to LOW level, hold the  $\overline{\text{BREQ}}$  terminal at LOW level until the  $\overline{\text{BACK}}$  terminal becomes LOW level. If the  $\overline{\text{BREQ}}$  terminal is returned to HIGH level, before the  $\overline{\text{BACK}}$  terminal becomes LOW level, the shift to the bus authorization release status will become indefinite.*

There is no bus authority release function in the E0C88308.

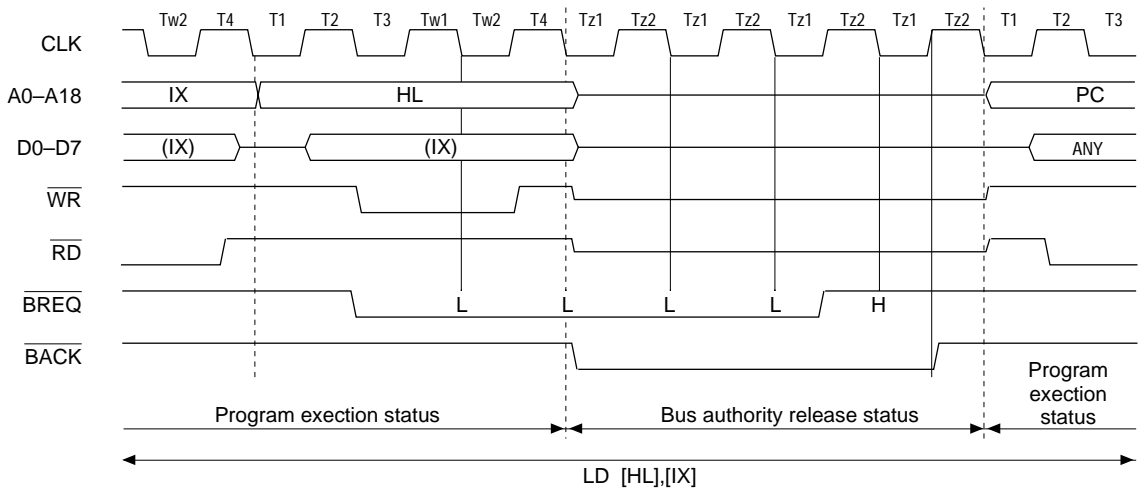

Fig. 3.6.6.2 Bus authority release sequence

# 4 INITIAL RESET

Initial reset in the E0C883xx is required in order to initialize circuits. This section of the Manual contains a description of initial reset factors and the initial settings for internal registers, etc.

## 4.1 Initial Reset Factors

There are three initial reset factors for the E0C883xx as shown below.

- (1)  $\overline{\text{RESET}}$  terminal
- (2) Simultaneous LOW level input at input port terminals K00–K03.
- (3) Supply voltage detection (SVD) circuit

Figure 4.1.1 shows the configuration of the initial reset circuit.

The CPU and peripheral circuits are initialized by means of initial reset factors. When the factor is canceled, the CPU commences reset exception processing. (See "E0C88 Core CPU Manual".)

When this occurs, reset exception processing vectors, Bank 0, 000000H–000001H from program memory are read out and the program (initialization routine) which begins at the readout address is executed.

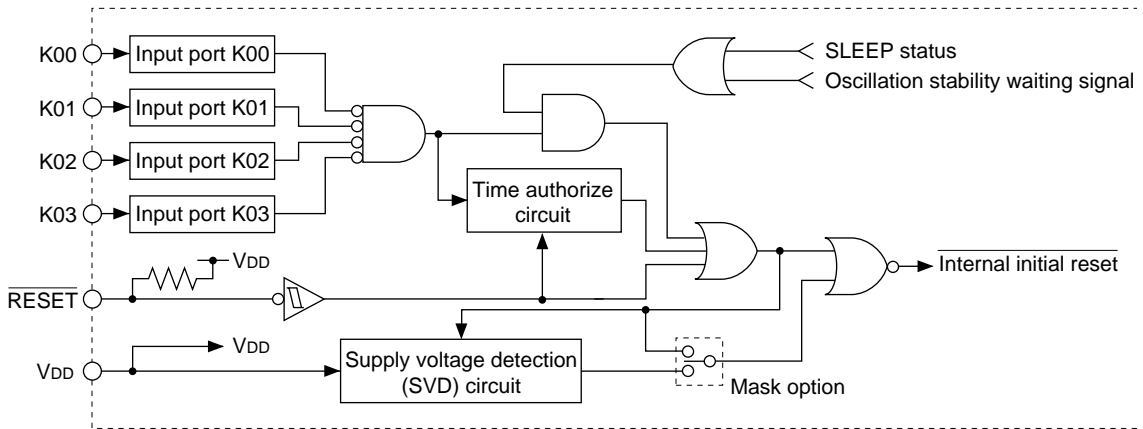

Fig. 4.1.1 Configuration of initial reset circuit

### 4.1.1 $\overline{\text{RESET}}$ terminal

Initial reset can be done by executed externally inputting a LOW level to the  $\overline{\text{RESET}}$  terminal. Be sure to maintain the  $\overline{\text{RESET}}$  terminal at LOW level for the regulation time after the power on to assure the initial reset.

In addition, be sure to use the  $\overline{\text{RESET}}$  terminal for the first initial reset after the power is turned on. The  $\overline{\text{RESET}}$  terminal is equipped with a pull-up resistor. You can select whether or not to use by mask option.

### 4.1.2 Simultaneous LOW level input at input port terminals K00–K03

Another way of executing initial reset externally is to input a LOW level simultaneously to the input ports (K00–K03) selected by mask option.

Since there is a built-in time authorize circuit, be sure to maintain the designated input port terminal at LOW level for two seconds (when the oscillation frequency is  $f_{\text{OSC1}} = 32.768 \text{ kHz}$ ) or more to perform the initial reset by means of this function. However, the time authorize circuit is bypassed during the SLEEP (standby) status and oscillation stabilization waiting period, and initial reset is executed immediately after the simultaneous LOW level input to the designated input ports.

The combination of input ports (K00–K03) that can be selected by mask option are as follows:

- (1) Not use
- (2) K00 & K01
- (3) K00 & K01 & K02
- (4) K00 & K01 & K02 & K03

For instance, let's say that mask option (4) "K00 & K01 & K02 & K03" is selected.

When the input level at input ports K00–K03 is simultaneously LOW, initial reset will take place.

When using this function, make sure that the designated input ports do not simultaneously switch to LOW level while the system is in normal operation.

### 4.1.3 Supply voltage detection (SVD) circuit

When the SVD circuit detects that supply voltage has dropped below level 0 four successive times (see Chapter 7, "ELECTRICAL CHARACTERISTICS"), it outputs an initial reset signal until the supply voltage has been restored to level 2.

You can select whether or not to use the initial reset according to the SVD circuit by mask option. If you use it, the supply voltage must be at least level 2 for the first sampling of the SVD circuit, when the power is turned on. At this time, if the power voltage level is less than level 2, the initial reset status will not be canceled and instead the SVD circuit will continue sampling until the supply voltage reaches level 2 or more.

For more information, see "5.15 Supply Voltage Detection (SVD) Circuit" in this Manual.

### 4.1.4 Initial reset sequence

After cancellation of the LOW level input to the  $\overline{\text{RESET}}$  terminal, when the power is turned on, the start-up of the CPU is held back until the oscillation stabilization waiting time ( $8,192/f_{\text{OSC1}} \text{ sec.}$ ) has elapsed. When the initial reset by the SVD circuit has been used, an initial sampling time ( $248/f_{\text{OSC1}} \text{ sec.}$ ) is added as additional waiting time.

Figure 4.1.4.1 shows the operating sequence following initial reset release.

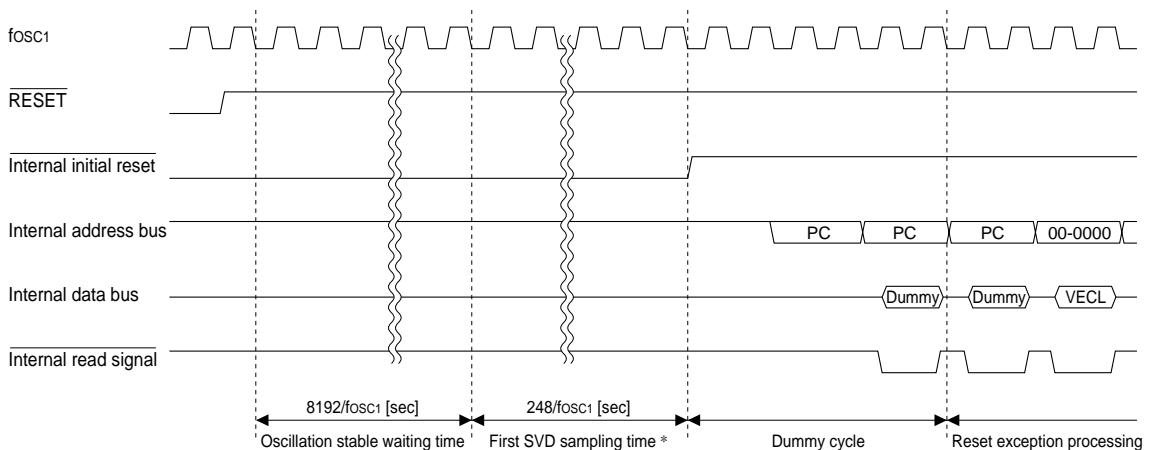

\* When the initial reset by the SVD circuit with the mask option has been used, this cycle is inserted as the waiting time.

Fig. 4.1.4.1 Initial reset sequence

Also, when using the initial reset by simultaneous LOW level input into the input port, you should be careful of the following points.

- (1) During SLEEP status, since the time authorization circuit is bypassed, an initial reset is triggered immediately after a LOW level simultaneous input value. In this case, the CPU starts after waiting the oscillation stabilization time and the SVD circuit initial sampling time (when used with the mask option), following cancellation of the LOW level simultaneous input.
- (2) Other than during SLEEP status, an initial reset will be triggered 1–2 seconds after a LOW level simultaneous input. In this case, since a reset differential pulse (64/fOSC1 sec.) is generated within the E0C883xx, the CPU will start even if the LOW level simultaneous input status is not canceled.

## 4.2 Initial Settings After Initial Reset

The CPU internal registers are initialized as follows during initial reset.

Table 4.2.1 Initial settings

Register name	Code	Bit length	Setting value
Data register A	A	8	Undefined
Data register B	B	8	Undefined
Index (data) register L	L	8	Undefined
Index (data) register H	H	8	Undefined
Index register IX	IX	16	Undefined
Index register IY	IY	16	Undefined
Program counter	PC	16	Undefined*
Stack pointer	SP	16	Undefined
Base register	BR	8	Undefined
Zero flag	Z	1	0
Carry flag	C	1	0
Overflow flag	V	1	0
Negative flag	N	1	0
Decimal flag	D	1	0
Unpack flag	U	1	0
Interrupt flag 0	I0	1	1
Interrupt flag 1	I1	1	1
New code bank register	NB	8	01H
Code bank register	CB	8	Undefined*
Expand page register	EP	8	00H
Expand page register for IX	XP	8	00H
Expand page register for IY	YP	8	00H

\* Reset exception processing loads the preset values stored in 0 bank, 0000H–0001H into the PC. At the same time, 01H of the NB initial value is loaded into CB.

Initialize the registers which are not initialized at initial reset using software.

Since the internal RAM and display memory are not initialized at initial reset, be sure to initialize using software.

The respectively stipulated initializations are done for internal peripheral circuits. If necessary, the initialization should be done using software. For initial value at initial reset, see the sections on the I/O memory map and peripheral circuit descriptions in the following chapter of this Manual.

# ***5 PERIPHERAL CIRCUITS AND THEIR OPERATION***

The peripheral circuits of the E0C883xx is interfaced with the CPU by means of the memory mapped I/O method. For this reason, just as with other memory access operations, peripheral circuits can be controlled by manipulating I/O memory. Below is a description of the operation and control method for each individual peripheral circuit.

## 5.1 I/O Memory Map

Table 5.1.1(a) I/O Memory map (00FF00H–00FF02H, MCU mode)

Address	Bit	Name	Function	1	0	SR	R/W	Comment	
00FF00 (MCU)	D7	BSMD1	Bus mode (CPU mode)			0	R/W		
			BSMD1 BSMD0 Mode						
			1 1 512K (Maximum)						
	D6	BSMD0	1 0 512K (Minimum)			0	R/W		
			0 1 64K						
			0 0 Single chip						
	D5	CEMD1	Chip enable mode			1	R/W		
			CEMD1 CEMD0 Mode						
			1 1 64K ( $\overline{CE0}$ )						
			1 0 32K ( $\overline{CE0}$ , $\overline{CE1}$ )						
D4	CEMD0	0 1 16K ( $\overline{CE0}$ – $\overline{CE3}$ ...E0C88308) ( $\overline{CE1}$ – $\overline{CE3}$ ...E0C88316)			1	R/W			
		0 0 8K ( $\overline{CE0}$ – $\overline{CE3}$ )							
D3	CE3	$\overline{CE3}$ (R33)	$\overline{CE}$ signal output Enable/Disable Enable: $\overline{CE}$ signal output Disable: DC (R3x) output	$\overline{CE3}$ enable	$\overline{CE3}$ disable	0	R/W		
D2	CE2	$\overline{CE2}$ (R32)		$\overline{CE2}$ enable	$\overline{CE2}$ disable	0	R/W		
D1	CE1	$\overline{CE1}$ (R31)		$\overline{CE1}$ enable	$\overline{CE1}$ disable	0	R/W		
D0	CE0	$\overline{CE0}$ (R30)		$\overline{CE0}$ enable	$\overline{CE0}$ disable	0	R/W		
00FF01	D7	SPP7	Stack pointer page address (MSB)	1	0	0	R/W		
	D6	SPP6		1	0	0	R/W		
	D5	SPP5		< SP page allocatable address >	1	0	0	R/W	
	D4	SPP4		• Single chip mode: only 0 page	1	0	0	R/W	
	D3	SPP3		• 64K mode: only 0 page	1	0	0	R/W	
	D2	SPP2		• 512K (min) mode: 0–27H page	1	0	0	R/W	
	D1	SPP1		• 512K (max) mode: 0–27H page	1	0	0	R/W	
	D0	SPP0		(LSB)	1	0	0	R/W	
00FF02	D7	EBR	Bus release enable register (K11 and R51 terminal specification)	K11 R51	BREQ BACK	Input port Output port	0	R/W	*2
	D6	WT2	Wait control register	Number of state					
			WT2 WT1 WT0						
			1 1 1 14						
			1 1 0 12						
	D5	WT1	1 0 1 10			0	R/W		
			1 0 0 8						
			0 1 1 6						
			0 1 0 4						
	D4	WT0	0 0 1 2						
	0 0 0 No wait								
D3	CLKCHG	CPU operating clock switch	OSC3	OSC1	0	R/W			
D2	OSCC	OSC3 oscillation On/Off control	On	Off	0	R/W			
D1	VDC1	Operating mode selection							
		VDC1 VDC0 Operating mode							
		1 × High speed ( $V_{D1}$ =3.3V)			0	R/W			
		0 1 Low power ( $V_{D1}$ =1.3V)							
D0	VDC0	0 0 Normal ( $V_{D1}$ =2.2V)							

\*1 This is just R/W register on E0C88348/317. \*2 This is just R/W register on E0C88308.

Note: All the interrupts including  $\overline{NMI}$  are disabled, until you write the optional value into both the "00FF00H" and "00FF01H" addresses.

Table 5.1.1(b) I/O Memory map (00FF00H–00FF02H, MPU mode)

Address	Bit	Name	Function	1	0	SR	R/W	Comment	
00FF00 (MPU)	D7	BSMD1	Bus mode (CPU mode) BSMD1 BSMD0 Mode	}	}	*	R/W	* Initial setting can be selected among 3 types (64K, 512K min and 512K max) by mask option setting.	
			1 1 512K (Maximum)						
	D6	BSMD0	1 0 512K (Minimum)						
			0 1 64K						
			0 0 * Option selection ←						
	D5	CEMD1	Chip enable mode CEMD1 CEMD0 Mode	}	}	1	R/W		
			1 1 64K (CE0)						
	D4	CEMD0	1 0 32K (CE0, CE1)						
			0 1 16K (CE0–CE3)						
			0 0 8K (CE0–CE3)						
D3	CE3	CE3 (R33)	CE signal output Enable/Disable Enable: CE signal output Disable: DC (R3x) output	CE3 enable	CE3 disable	0	R/W		
D2	CE2	CE2 (R32)		CE2 enable	CE2 disable	0	R/W		
D1	CE1	CE1 (R31)		CE1 enable	CE1 disable	0	R/W		
D0	CE0	CE0 (R30)		CE0 enable	CE0 disable	1	R/W		
00FF01	D7	SPP7	Stack pointer page address (MSB)	1	0	0	R/W		
	D6	SPP6		1	0	0	R/W		
	D5	SPP5	< SP page allocatable address >	1	0	0	R/W		
	D4	SPP4	• Single chip mode: only 0 page	1	0	0	R/W		
	D3	SPP3	• 64K mode: only 0 page	1	0	0	R/W		
	D2	SPP2	• 512K (min) mode: 0–27H page	1	0	0	R/W		
	D1	SPP1	• 512K (max) mode: 0–27H page	1	0	0	R/W		
	D0	SPP0	(LSB)	1	0	0	R/W		
00FF02	D7	EBR	Bus release enable register (K11 and R51 terminal specification)	K11 BREQ	R51 BACK	Input port Output port	0	R/W	*1
	D6	WT2	Wait control register WT2 WT1 WT0 Number of state	}	}	0	R/W		
			1 1 1 14						
			1 1 0 12						
	D5	WT1	1 0 1 10						
			0 1 1 6						
			0 1 0 4						
	D4	WT0	0 0 1 2						
			0 0 0 No wait						
	D3	CLKCHG	CPU operating clock switch	OSC3	OSC1	0	R/W		
D2	OSCC	OSC3 oscillation On/Off control	On	Off	0	R/W			
D1	VDC1	Operating mode selection VDC1 VDC0 Operating mode	}	}	0	R/W			
		1 × High speed (VD1=3.3V)							
D0	VDC0	0 1 Low power (VD1=1.3V)							
		0 0 Normal (VD1=2.2V)							

\*1 This is just R/W register on E0C88308.

Note: All the interrupts including  $\overline{NMI}$  are disabled, until you write the optional value into both the "00FF00H" and "00FF01H" addresses.

## 5 PERIPHERAL CIRCUITS AND THEIR OPERATION (I/O Memory Map)

Table 5.1.1(c) I/O Memory map (00FF10H–00FF13H)

Address	Bit	Name	Function	1	0	SR	R/W	Comment		
00FF10	D7	–	–	–	–	–		Constrant "0" when being read		
	D6	–	–	–	–	–				
	D5	–	–	–	–	–				
	D4	LCCLK	CL output control for expanded LCD driver	On	Off	0	R/W			
	D3	LCFRM	FR output control for expanded LCD driver	On	Off	0	R/W			
	D2	DTFNT	LCD dot font selection	5 x 5 dots	5 x 8 dots	0	R/W			
	D1	LDUTY	LCD drive duty selection	1/16 duty	1/32 duty	0	R/W			
	D0	SGOUT	R/W register	1	0	0	R/W			
00FF11	D7	–	–	–	–	–		"0" when being read		
	D6	DSPAR	LCD display memory area selection	Display area 1	Display area 0	0	R/W	These bits are reset to (0, 0) when SLP instruction is executed.		
	D5	LCDC1	LCD display control				0		R/W	
			LCDC1	LCDC0	LCD display					
			1	1	All LCDs lit					
	D4	LCDC0			1	0	0	R/W		
					0	1	Normal display			
					0	0	Drive off			
	D3	LC3	LCD contrast adjustment				0	R/W		
	D2	LC2	LC3	LC2	LC1	LC0	Contrast	0	R/W	
D1	LC1	1	1	1	0	Dark	0	R/W		
D0	LC0	:	:	:	:	:	0	R/W		
00FF12	D7	–	–	–	–	–		Constrant "0" when being read		
	D6	–	–	–	–	–				
	D5	SVDSP	SVD auto-sampling control	On	Off	0	R/W	These registers are reset to "0" when		
	D4	SVDON	SVD continuous sampling control/status	R	Busy	Ready	1→0*2	R/W	SLP instruction is executed.	
				W	On	Off	0			
	D3	SVD3	SVD detection level				X	R	*3	
	D2	SVD2	SVD3	SVD2	SVD1	SVD0	Detection level	X		R
	D1	SVD1	1	1	1	0	Level 15	X		R
D0	SVD0			:	:	:				
				0	0	0	0	Level 0		
00FF13	D7	–	–	–	–	–		Constantly "0" when being read		
	D6	–	–	–	–	–				
	D5	–	–	–	–	–				
	D4	–	–	–	–	–				
	D3	CMP1ON	Comparator 1 On/Off control	On	Off	0	R/W			
	D2	CMP0ON	Comparator 0 On/Off control	On	Off	0	R/W			
	D1	CMP1DT	Comparator 1 data	+ > -	+ < -	0	R			
	D0	CMP0DT	Comparator 0 data	+ > -	+ < -	0	R			

\*1 When 1/8 duty has been selected by mask option, setting of this register becomes invalid.

\*2 After initial reset, this status is set "1" until conclusion of hardware first sampling.

\*3 Initial values are set according to the supply voltage detected at first sampling by hardware. Until conclusion of first sampling, SVD0–SVD3 data are undefined.



Table 5.1.1(d) I/O Memory map (00FF20H–00FF25H)

Address	Bit	Name	Function	1	0	SR	R/W	Comment	
00FF20	D7	PK01	K00–K07 interrupt priority register	PK01 PK00 PSIF1 PSIF0 PSW1 PSW0 PTM1 PTM0 1 1 1 0 0 1 0 0	Priority level Level 3 Level 2 Level 1 Level 0	0	R/W		
	D6	PK00							
	D5	PSIF1	Serial interface interrupt priority register						
	D4	PSIF0							
	D3	PSW1	Stopwatch timer interrupt priority register						
	D2	PSW0							
	D1	PTM1	Clock timer interrupt priority register						
D0	PTM0								
00FF21	D7	–	–	–	–	–	–	Constantly "0" when being read	
	D6	–	–	–	–	–	–		
	D5	–	–	–	–	–	–		–
	D4	–	–	–	–	–	–		–
	D3	PPT1	Programmable timer interrupt priority register	PPT1 PPT0	Priority level	0	R/W		
	D2	PPT0		PK11 PK10	Level 3				
	D1	PK11	K10 and K11 interrupt priority register	1 0	Level 2	0	R/W		
D0	PK10	0 1		Level 1					
			0 0	Level 0					
00FF22	D7	–	–	–	–	–	–	"0" when being read	
	D6	ESW100	Stopwatch timer 100 Hz interrupt enable register	Interrupt enable	Interrupt disable	0	R/W		
	D5	ESW10	Stopwatch timer 10 Hz interrupt enable register						
	D4	ESW1	Stopwatch timer 1 Hz interrupt enable register						
	D3	ETM32	Clock timer 32 Hz interrupt enable register						
	D2	ETM8	Clock timer 8 Hz interrupt enable register						
	D1	ETM2	Clock timer 2 Hz interrupt enable register						
D0	ETM1	Clock timer 1 Hz interrupt enable register							
00FF23	D7	EPT1	Programmable timer 1 interrupt enable register	Interrupt enable	Interrupt disable	0	R/W		
	D6	EPT0	Programmable timer 0 interrupt enable register						
	D5	EK1	K10 and K11 interrupt enable register						
	D4	EK0H	K04–K07 interrupt enable register						
	D3	EK0L	K00–K03 interrupt enable register						
	D2	ESERR	Serial I/F (error) interrupt enable register						
	D1	ESREC	Serial I/F (receiving) interrupt enable register						
D0	ESTRA	Serial I/F (transmitting) interrupt enable register							
00FF24	D7	–	–	–	–	–	–	"0" when being read	
	D6	FSW100	Stopwatch timer 100 Hz interrupt factor flag	(R)	(R)	0	R/W		
	D5	FSW10	Stopwatch timer 10 Hz interrupt factor flag	Interrupt factor is generated	No interrupt factor is generated				
	D4	FSW1	Stopwatch timer 1 Hz interrupt factor flag						
	D3	FTM32	Clock timer 32 Hz interrupt factor flag						
	D2	FTM8	Clock timer 8 Hz interrupt factor flag						
	D1	FTM2	Clock timer 2 Hz interrupt factor flag						
D0	FTM1	Clock timer 1 Hz interrupt factor flag	(W) Reset	(W) No operation					
00FF25	D7	FPT1	Programmable timer 1 interrupt factor flag	(R)	(R)	0	R/W		
	D6	FPT0	Programmable timer 0 interrupt factor flag	Interrupt factor is generated	No interrupt factor is generated				
	D5	FK1	K10 and K11 interrupt factor flag						
	D4	FK0H	K04–K07 interrupt factor flag						
	D3	FK0L	K00–K03 interrupt factor flag						
	D2	FSERR	Serial I/F (error) interrupt factor flag						
	D1	FSREC	Serial I/F (receiving) interrupt factor flag						
D0	FSTR	Serial I/F (transmitting) interrupt factor flag	(W) Reset	(W) No operation					

## 5 PERIPHERAL CIRCUITS AND THEIR OPERATION (I/O Memory Map)

Table 5.1.1(e) I/O Memory map (00FF30H–00FF33H)

Address	Bit	Name	Function	1	0	SR	R/W	Comment		
00FF30	D7	–	–	–	–	–		Constrant "0" when being read		
	D6	–	–	–	–	–				
	D5	–	–	–	–	–				
	D4	MODE16	8/16-bit mode selection		16-bit x 1	8-bit x 2	0	R/W		
	D3	CHSEL	TOUT output channel selection		Timer 1	Timer 0	0	R/W		
	D2	PTOUT	TOUT output control		On	Off	0	R/W		
	D1	CKSEL1	Prescaler 1 source clock selection		fosc3	fosc1	0	R/W		
	D0	CKSEL0	Prescaler 0 source clock selection		fosc3	fosc1	0	R/W		
00FF31	D7	EVCNT	Timer 0 counter mode selection		Event counter	Timer	0	R/W		
	D6	FCSEL	Timer 0 function selection	In timer mode	Pulse width measurement	Normal mode	0	R/W		
				In event counter mode	With noise rejector	Without noise rejector				
	D5	PLPOL	Timer 0 pulse polarity selection	Down count timing in event counter mode	Rising edge of K10 input	Falling edge of K10 input	0	R/W		
				In pulse width measurement mode	High level measurement for K10 input	Low level measurement for K10 input				
	D4	PSC01	Timer 0 prescaler dividing ratio selection					0	R/W	
			PSC01	PSC00	Prescaler dividing ratio					
	D3	PSC00	1 1 Source clock / 64					0	R/W	
			0 0 Source clock / 1							
	D2	CONT0	Timer 0 continuous/one-shot mode selection		Continuous	One-shot	0	R/W		
D1	PSET0	Timer 0 preset		Preset	No operation	–	W	"0" when being read		
D0	PRUN0	Timer 0 Run/Stop control		Run	Stop	0	R/W			
00FF32	D7	–	–	–	–	–		Constrant "0" when being read		
	D6	–	–	–	–	–				
	D5	–	–	–	–	–				
	D4	PSC11	Timer 1 prescaler dividing ratio selection					0	R/W	
			PSC11	PSC10	Prescaler dividing ratio					
	D3	PSC10	1 1 Source clock / 64					0	R/W	
			0 0 Source clock / 1							
	D2	CONT1	Timer 1 continuous/one-shot mode selection		Continuous	One-shot	0	R/W		
D1	PSET1	Timer 1 preset		Preset	No operation	–	W	"0" when being read		
D0	PRUN1	Timer 1 Run/Stop control		Run	Stop	0	R/W			
00FF33	D7	RLD07	Timer 0 reload data D7 (MSB)		High	Low	1	R/W		
	D6	RLD06	Timer 0 reload data D6							
	D5	RLD05	Timer 0 reload data D5							
	D4	RLD04	Timer 0 reload data D4							
	D3	RLD03	Timer 0 reload data D3							
	D2	RLD02	Timer 0 reload data D2							
	D1	RLD01	Timer 0 reload data D1							
	D0	RLD00	Timer 0 reload data D0 (LSB)							

Table 5.1.1(f) I/O Memory map (00FF34H–00FF36H)

Address	Bit	Name	Function	1	0	SR	R/W	Comment
00FF34	D7	RLD17	Timer 1 reload data D7 (MSB)	High	Low	1	R/W	
	D6	RLD16	Timer 1 reload data D6					
	D5	RLD15	Timer 1 reload data D5					
	D4	RLD14	Timer 1 reload data D4					
	D3	RLD13	Timer 1 reload data D3					
	D2	RLD12	Timer 1 reload data D2					
	D1	RLD11	Timer 1 reload data D1					
	D0	RLD10	Timer 1 reload data D0 (LSB)					
00FF35	D7	PTD07	Timer 0 counter data D7 (MSB)	High	Low	1	R	
	D6	PTD06	Timer 0 counter data D6					
	D5	PTD05	Timer 0 counter data D5					
	D4	PTD04	Timer 0 counter data D4					
	D3	PTD03	Timer 0 counter data D3					
	D2	PTD02	Timer 0 counter data D2					
	D1	PTD01	Timer 0 counter data D1					
	D0	PTD00	Timer 0 counter data D0 (LSB)					
00FF36	D7	PTD17	Timer 1 counter data D7 (MSB)	High	Low	1	R	
	D6	PTD16	Timer 1 counter data D6					
	D5	PTD15	Timer 1 counter data D5					
	D4	PTD14	Timer 1 counter data D4					
	D3	PTD13	Timer 1 counter data D3					
	D2	PTD12	Timer 1 counter data D2					
	D1	PTD11	Timer 1 counter data D1					
	D0	PTD10	Timer 1 counter data D0 (LSB)					

Table 5.1.1(g) I/O Memory map (00FF40H–00FF41H)

Address	Bit	Name	Function	1	0	SR	R/W	Comment
00FF40	D7	–	–	–	–	–		"0" when being read
	D6	FOUT2	FOUT frequency selection			0	R/W	
			<u>FOUT2</u> <u>FOUT1</u> <u>FOUT0</u> <u>Frequency</u>					
			0 0 0 fosc1 / 1					
			0 0 1 fosc1 / 2					
	D5	FOUT1	0 1 0 fosc1 / 4			0	R/W	
			0 1 1 fosc1 / 8					
	D4	FOUT0	1 0 0 fosc3 / 1			0	R/W	
			1 0 1 fosc3 / 2					
1 1 0 fosc3 / 4								
		1 1 1 fosc3 / 8						
D3	FOUTON	FOUT output control	On	Off	0	R/W		
D2	WDRST	Watchdog timer reset	Reset	No operation	–	W	Constantly "0" when	
D1	TMRST	Clock timer reset	Reset	No operation	–	W	being read	
D0	TMRUN	Clock timer Run/Stop control	Run	Stop	0	R/W		
00FF41	D7	TMD7	Clock timer data 1 Hz	High	Low	0	R	
	D6	TMD6	Clock timer data 2 Hz					
	D5	TMD5	Clock timer data 4 Hz					
	D4	TMD4	Clock timer data 8 Hz					
	D3	TMD3	Clock timer data 16 Hz					
	D2	TMD2	Clock timer data 32 Hz					
	D1	TMD1	Clock timer data 64 Hz					
	D0	TMD0	Clock timer data 128 Hz					

## 5 PERIPHERAL CIRCUITS AND THEIR OPERATION (I/O Memory Map)

Table 5.1.1(h) I/O Memory map (00FF42H–00FF45H)

Address	Bit	Name	Function	1	0	SR	R/W	Comment							
00FF42	D7	–	–	–	–	–		Constantly "0" when being read							
	D6	–	–	–	–	–									
	D5	–	–	–	–	–									
	D4	–	–	–	–	–									
	D3	–	–	–	–	–									
	D2	–	–	–	–	–									
	D1	SWRST	Stopwatch timer reset		Reset	No operation	–		W						
D0	SWRUN	Stopwatch timer Run/Stop control		Run	Stop	0	R/W								
00FF43	D7	SWD7	Stopwatch timer data			0	R								
	D6	SWD6													
	D5	SWD5	BCD (1/10 sec)												
	D4	SWD4													
	D3	SWD3	Stopwatch timer data												
	D2	SWD2													
	D1	SWD1	BCD (1/100 sec)												
	D0	SWD0													
00FF44	D7	–	–	–	–	–		Constantly "0" when being read							
	D6	BZSTP	One-shot buzzer forcibly stop	Forcibly stop	No operation	–	W								
	D5	BZSHT	One-shot buzzer trigger/status	R	Busy	Ready	0	R/W							
				W	Trigger	No operation									
	D4	SHTPW	One-shot buzzer duration width selection	125 msec	31.25 msec	0	R/W								
	D3	ENRTM	Envelope attenuation time	1 sec	0.5 sec	0	R/W								
	D2	ENRST	Envelope reset	Reset	No operation	–	W	"0" when being read							
	D1	ENON	Envelope On/Off control	On	Off	0	R/W	*1							
D0	BZON	Buzzer output control	On	Off	0	R/W									
00FF45	D7	–	–	–	–	–		"0" when being read							
	D6	DUTY2	Buzzer signal duty ratio selection			0	R/W								
									DUTY2–1		Buzzer frequency (Hz)				
									2	1	0	4096.0	3276.8	2730.7	2340.6
												2048.0	1638.4	1365.3	1170.3
	D5	DUTY1		0	0	0	8/16	8/20	12/24	12/28					
				0	0	1	7/16	7/20	11/24	11/28					
				0	1	0	6/16	6/20	10/24	10/28					
				0	1	1	5/16	5/20	9/24	9/28					
	D4	DUTY0		1	0	0	4/16	4/20	8/24	8/28					
1				0	1	3/16	3/20	7/24	7/28						
1				1	0	2/16	2/20	6/24	6/28						
1				1	1	1/16	1/20	5/24	5/28						
D3	–	–	–	–	–		"0" when being read								
D2	BZFQ2	Buzzer frequency selection				0	R/W								
									BZFQ2		BZFQ1		BZFQ0		Frequency (Hz)
D1	BZFQ1		0	0	0	4096.0									
			0	0	1	3276.8									
			0	1	0	2730.7									
			0	1	1	2340.6									
D0	BZFQ0		1	0	0	2048.0									
			1	0	1	1638.4									
			1	1	0	1365.3									
			1	1	1	1170.3									

\*1 Reset to "0" during one-shot output.

Table 5.1.1(i) I/O Memory map (00FF48H–00FF4AH)

Address	Bit	Name	Function	1	0	SR	R/W	Comment	
00FF48	D7	–	–	–	–	–		"0" when being read	
	D6	EPR	Parity enable register	With parity	Non parity	0	R/W	Only for asynchronous mode	
	D5	PMD	Parity mode selection	Odd	Even	0	R/W		
	D4	SCS1	Clock source selection	SCS1 SCS0 Clock source			0	R/W	In the clock synchronous slave mode, external clock is selected.
				1	1				
	D3	SCS0					0	R/W	
	D2	SMD1	Serial I/F mode selection	SMD1 SMD0 Mode			0	R/W	
				1	1				Asynchronous 8-bit
D1	SMD0					0	R/W		
								1	0
	D0	ESIF	Serial I/F enable register	Serial I/F	I/O port	0	R/W		
00FF49	D7	–	–	–	–	–		"0" when being read	
	D6	FER	Framing error flag	R	Error	No error	0	R/W	Only for asynchronous mode
				W	Reset (0)	No operation			
	D5	PER	Parity error flag	R	Error	No error	0	R/W	
				W	Reset (0)	No operation			
	D4	OER	Overrun error flag	R	Error	No error	0	R/W	
				W	Reset (0)	No operation			
	D3	RXTRG	Receive trigger/status	R	Run	Stop	0	R/W	
W				Trigger	No operation				
D2	RXEN	Receive enable		Enable	Disable	0	R/W		
D1	TXTRG	Transmit trigger/status	R	Run	Stop	0	R/W		
			W	Trigger	No operation				
D0	TXEN	Transmit enable		Enable	Disable	0	R/W		
00FF4A	D7	TRXD7	Transmit/Receive data D7 (MSB)	High	Low	X	R/W		
	D6	TRXD6	Transmit/Receive data D6						
	D5	TRXD5	Transmit/Receive data D5						
	D4	TRXD4	Transmit/Receive data D4						
	D3	TRXD3	Transmit/Receive data D3						
	D2	TRXD2	Transmit/Receive data D2						
	D1	TRXD1	Transmit/Receive data D1						
	D0	TRXD0	Transmit/Receive data D0 (LSB)						

## 5 PERIPHERAL CIRCUITS AND THEIR OPERATION (I/O Memory Map)

Table 5.1.1(j) I/O Memory map (00FF50H–00FF55H)

Address	Bit	Name	Function	1	0	SR	R/W	Comment
00FF50	D7	SIK07	K07 interrupt selection register	Interrupt enable	Interrupt disable	0	R/W	
	D6	SIK06	K06 interrupt selection register					
	D5	SIK05	K05 interrupt selection register					
	D4	SIK04	K04 interrupt selection register					
	D3	SIK03	K03 interrupt selection register					
	D2	SIK02	K02 interrupt selection register					
	D1	SIK01	K01 interrupt selection register					
	D0	SIK00	K00 interrupt selection register					
00FF51	D7	–	–	–	–	–		Constantly "0" when being read
	D6	–	–	–	–	–		
	D5	–	–	–	–	–		
	D4	–	–	–	–	–		
	D3	–	–	–	–	–		
	D2	–	–	–	–	–		
	D1	SIK11	K11 interrupt selection register	Interrupt enable	Interrupt disable	0	R/W	*1
	D0	SIK10	K10 interrupt selection register					
00FF52	D7	KCP07	K07 interrupt comparison register	Interrupt generated at falling edge	Interrupt generated at rising edge	1	R/W	
	D6	KCP06	K06 interrupt comparison register					
	D5	KCP05	K05 interrupt comparison register					
	D4	KCP04	K04 interrupt comparison register					
	D3	KCP03	K03 interrupt comparison register					
	D2	KCP02	K02 interrupt comparison register					
	D1	KCP01	K01 interrupt comparison register					
	D0	KCP00	K00 interrupt comparison register					
00FF53	D7	–	–	–	–	–		Constantly "0" when being read
	D6	–	–	–	–	–		
	D5	–	–	–	–	–		
	D4	–	–	–	–	–		
	D3	–	–	–	–	–		
	D2	–	–	–	–	–		
	D1	KCP11	K11 interrupt comparison register	Falling edge	Rising edge	1	R/W	*2
	D0	KCP10	K10 interrupt comparison register					
00FF54	D7	K07D	K07 input port data	High level input	Low level input	–	R	
	D6	K06D	K06 input port data					
	D5	K05D	K05 input port data					
	D4	K04D	K04 input port data					
	D3	K03D	K03 input port data					
	D2	K02D	K02 input port data					
	D1	K01D	K01 input port data					
	D0	K00D	K00 input port data					
00FF55	D7	–	–	–	–	–		Constantly "0" when being read
	D6	–	–	–	–	–		
	D5	–	–	–	–	–		
	D4	–	–	–	–	–		
	D3	–	–	–	–	–		
	D2	–	–	–	–	–		
	D1	K11D	K11 input port data	High level input	Low level input	–	R	*3
	D0	K10D	K10 input port data					

\*1 Set constantly "0" on E0C88308.

\*3 Constantly "1" when being read on E0C88308.

\*2 Set constantly "1" on E0C88308.

Table 5.1.1(k) I/O Memory map (00FF60H–00FF63H)

Address	Bit	Name	Function	1	0	SR	R/W	Comment
00FF60	D7	IOC07	P07 I/O control register	Output	Input	0	R/W	
	D6	IOC06	P06 I/O control register					
	D5	IOC05	P05 I/O control register					
	D4	IOC04	P04 I/O control register					
	D3	IOC03	P03 I/O control register					
	D2	IOC02	P02 I/O control register					
	D1	IOC01	P01 I/O control register					
	D0	IOC00	P00 I/O control register					
00FF61	D7	IOC17	P17 I/O control register	Output	Input	0	R/W	
	D6	IOC16	P16 I/O control register					
	D5	IOC15	P15 I/O control register					
	D4	IOC14	P14 I/O control register					
	D3	IOC13	P13 I/O control register					
	D2	IOC12	P12 I/O control register					
	D1	IOC11	P11 I/O control register					
	D0	IOC10	P10 I/O control register					
00FF62	D7	P07D	P07 I/O port data	High	Low	1	R/W	
	D6	P06D	P06 I/O port data					
	D5	P05D	P05 I/O port data					
	D4	P04D	P04 I/O port data					
	D3	P03D	P03 I/O port data					
	D2	P02D	P02 I/O port data					
	D1	P01D	P01 I/O port data					
	D0	P00D	P00 I/O port data					
00FF63	D7	P17D	P17 I/O port data	High	Low	1	R/W	
	D6	P16D	P16 I/O port data					
	D5	P15D	P15 I/O port data					
	D4	P14D	P14 I/O port data					
	D3	P13D	P13 I/O port data					
	D2	P12D	P12 I/O port data					
	D1	P11D	P11 I/O port data					
	D0	P10D	P10 I/O port data					

## 5 PERIPHERAL CIRCUITS AND THEIR OPERATION (I/O Memory Map)

Table 5.1.1(l) I/O Memory map (00FF70H–00FF75H)

Address	Bit	Name	Function	1	0	SR	R/W	Comment
00FF70	D7	HZR51	R51 high impedance control	High impedance	Complementary	0	R/W	*1
	D6	HZR50	R50 high impedance control					
	D5	HZR4H	R/W register	1	0	0	R/W	Reserved register
	D4	HZR4L	R/W register					
	D3	HZR1H	R14–R17 high impedance control	High impedance	Complementary	0	R/W	
	D2	HZR1L	R10–R13 high impedance control					
	D1	HZR0H	R04–R07 high impedance control					
	D0	HZR0L	R00–R03 high impedance control					
00FF71	D7	HZR27	R27 high impedance control	High impedance	Complementary	0	R/W	
	D6	HZR26	R26 high impedance control					
	D5	HZR25	R25 high impedance control					
	D4	HZR24	R24 high impedance control					
	D3	HZR23	R23 high impedance control					
	D2	HZR22	R22 high impedance control					
	D1	HZR21	R21 high impedance control					
	D0	HZR20	R20 high impedance control					
00FF72	D7	HZR37	R37 high impedance control	High impedance	Complementary	0	R/W	These are just R/W registers on E0C88308
	D6	HZR36	R36 high impedance control					
	D5	HZR35	R35 high impedance control					
	D4	HZR34	R34 high impedance control					
	D3	HZR33	R33 high impedance control					
	D2	HZR32	R32 high impedance control					
	D1	HZR31	R31 high impedance control					
	D0	HZR30	R30 high impedance control					
00FF73	D7	R07D	R07 output port data	High	Low	1	R/W	
	D6	R06D	R06 output port data					
	D5	R05D	R05 output port data					
	D4	R04D	R04 output port data					
	D3	R03D	R03 output port data					
	D2	R02D	R02 output port data					
	D1	R01D	R01 output port data					
	D0	R00D	R00 output port data					
00FF74	D7	R17D	R17 output port data	High	Low	1	R/W	
	D6	R16D	R16 output port data					
	D5	R15D	R15 output port data					
	D4	R14D	R14 output port data					
	D3	R13D	R13 output port data					
	D2	R12D	R12 output port data					
	D1	R11D	R11 output port data					
	D0	R10D	R10 output port data					
00FF75	D7	R27D	R27 output port data	High	Low	1	R/W	
	D6	R26D	R26 output port data					
	D5	R25D	R25 output port data					
	D4	R24D	R24 output port data					
	D3	R23D	R23 output port data					
	D2	R22D	R22 output port data					
	D1	R21D	R21 output port data					
	D0	R20D	R20 output port data					

\*1 This is just R/W register on E0C88308.



Table 5.1.1(m) I/O Memory map (00FF76H–00FF78H)

Address	Bit	Name	Function	1	0	SR	R/W	Comment
00FF76	D7	R37D	R37 output port data	High	Low	1	R/W	These are just R/W registers on E0C88308
	D6	R36D	R36 output port data					
	D5	R35D	R35 output port data					
	D4	R34D	R34 output port data					
	D3	R33D	R33 output port data					
	D2	R32D	R32 output port data					
	D1	R31D	R31 output port data					
	D0	R30D	R30 output port data					
00FF77	D7	R47D	R/W register	1	0	1	R/W	Reserved register
	D6	R46D	R/W register					
	D5	R45D	R/W register					
	D4	R44D	R/W register					
	D3	R43D	R/W register					
	D2	R42D	R/W register					
	D1	R41D	R/W register					
	D0	R40D	R/W register					
00FF78	D7	–	–	–	–	–	–	Constantly "0" when being read
	D6	–	–	–	–	–	–	
	D5	–	–	–	–	–	–	
	D4	–	–	–	–	–	–	
	D3	–	–	–	–	–	–	
	D2	–	–	–	–	–	–	
	D1	R51D	R51 output port data	High	Low	1	R/W	*1
	D0	R50D	R50 output port data	High	Low	0	R/W	

\*1 This is just R/W register on E0C88308.

## 5.2 System Controller and Bus Control

The system controller is a management unit which sets such items as the bus mode in accordance with memory system configuration factors.

For the purposes of controlling the system, the following settings can be performed in software:

- (1) Bus mode (CPU mode) settings
- (2) Chip enable ( $\overline{CE}$ ) signal output settings
- (3) WAIT state settings for external memory
- (4) Bus authority release request / acknowledge signal ( $\overline{BREQ}/\overline{BACK}$ ) settings
- (5) Page address setting of the stack pointer

*Note: There is no bus authority release function in the E0C88308.*

Below is a description of the how these settings are to be made.

### 5.2.1 Bus mode settings

As explained in "3.5.2 Bus mode", the E0C883xx has four bus modes. Settings for bus modes must be made in software and must match the capacity of the external memory.

As shown in Table 5.2.1.1, bus mode settings are performed on the basis of the preset values for each mode written to the registers BSMD0 and BSMD1.

Table 5.2.1.1 Bus mode settings

Setting value		Bus mode	Configuration of external memory
BSMD1	BSMD0		
1	1	Expanded 512K maximum mode	ROM+RAM>64K bytes (Program>64K bytes)
1	0	Expanded 512K minimum mode	ROM+RAM>64K bytes (Program≤64K bytes)
0	1	Expanded 64K mode	ROM+RAM≤64K bytes
0	0	Single chip mode (MCU)	None
		Optional setting of one of the expanded modes (MPU)	See above

- \* The single chip mode setting is only possible when this IC is used in the MCU mode. The single chip mode setting is incompatible with the MPU mode, since this mode does not utilize internal ROM.  
When using in the MPU mode, it is necessary to select the bus mode at the time of the initial resetting and at the time of the <BSMD1 = "0" and BSMD0 = "0"> setting from among the three types of expanded modes (expanded 64K mode, expanded 512K minimum mode and expanded 512K maximum mode) by mask option.  
Select the expanded 512K maximum mode for this option, when the MPU mode is not used at all.

The function of I/O terminals is set as shown in Table 5.2.1.2 in accordance with mode selection.

Table 5.2.1.2 I/O terminal settings

Terminal	Bus mode		
	Single chip	Expanded 64K mode	Expanded 512K mode
R00	Output port R00		Address bus A0
R01	Output port R01		Address bus A1
R02	Output port R02		Address bus A2
R03	Output port R03		Address bus A3
R04	Output port R04		Address bus A4
R05	Output port R05		Address bus A5
R06	Output port R06		Address bus A6
R07	Output port R07		Address bus A7
R10	Output port R10		Address bus A8
R11	Output port R11		Address bus A9
R12	Output port R12		Address bus A10
R13	Output port R13		Address bus A11
R14	Output port R14		Address bus A12
R15	Output port R15		Address bus A13
R16	Output port R16		Address bus A14
R17	Output port R17		Address bus A15
R20	Output port R20		Address bus A16
R21	Output port R21		Address bus A17
R22	Output port R22		Address bus A18
R23	Output port R23	$\overline{\text{RD}}$ signal	
R24	Output port R24	$\overline{\text{WR}}$ signal	
P00	I/O port P00		Data bus D0
P01	I/O port P01		Data bus D1
P02	I/O port P02		Data bus D2
P03	I/O port P03		Data bus D3
P04	I/O port P04		Data bus D4
P05	I/O port P05		Data bus D5
P06	I/O port P06		Data bus D6
P07	I/O port P07		Data bus D7

At initial reset, the bus mode is set as explained below.

- In MCU mode:**  
 At initial reset, the E0C883xx is set in single chip mode.  
 Accordingly, in MCU mode, even if a memory has been externally expanded, the system is activated by the program written to internal ROM.  
 In systems with externally expanded memory, perform the applicable bus mode settings during the initialization routine originating in internal ROM.
- In MPU mode:**  
 When the MPU mode is used, the expanded mode (expanded 64K mode, expanded 512K minimum mode or expanded 512K maximum mode) set during initial reset must be pre-selected by mask option.  
 You should set it to conform properly to system configuration.

### 5.2.2 Address decoder ( $\overline{CE}$ output) settings

As explained in Section 3.6.4, the E0C883xx is equipped with address decoders that can output a maximum of four chip enable signals ( $\overline{CE0}$ – $\overline{CE3}$ ) to external devices.

The output terminals and output circuits for  $\overline{CE0}$ – $\overline{CE3}$  are shared with output ports R30–R33. At initial reset, they are set as output port terminals. For this reason, when operating in a mode other than single chip mode, the ports to be used as  $\overline{CE}$  signal output terminals must be set as such.

This setting is performed through software which writes "1" to registers CE0–CE3 corresponding the  $\overline{CE}$  signals to be used.

Table 5.2.2.1 shows the address range assigned to the four chip enable ( $\overline{CE}$ ) signals.

The arrangement of memory space for external devices does not necessarily have to be continuous from a subordinate address and any of the chip enable signals can be used to assign areas in memory. However, in the MPU mode, program memory must be assigned to  $\overline{CE0}$ .

In the expanded 512K mode, the address range of each of the  $\overline{CE}$  signals is fixed. In the expanded 64K mode, the four address ranges, which match the amount of memory in use, are selected with registers CEMD0 and CEMD1.

These signals are only output when the appointed external memory area is accessed and are not output when internal memory is accessed.

Table 5.2.2.1 Address settings of  $\overline{CE0}$ – $\overline{CE3}$

(1) Expanded 64K mode + MCU mode (E0C88316)

CEMD1	CEMD0	Chip size	$\overline{CE0}$	$\overline{CE1}$	$\overline{CE2}$	$\overline{CE3}$
1	1	64K bytes	004000H–00EFFFH	–	–	–
1	0	32K bytes	004000H–007FFFH	008000H–00EFFFH	–	–
0	1	16K bytes	–	004000H–007FFFH	008000H–00BFFFH	00C000H–00EFFFH
0	0	8K bytes	008000H–009FFFH	00A000H–00BFFFH	004000H–005FFFH	006000H–007FFFH

(2) Expanded 64K mode + MCU mode (E0C88308)

CEMD1	CEMD0	Chip size	$\overline{CE0}$	$\overline{CE1}$	$\overline{CE2}$	$\overline{CE3}$
1	1	64K bytes	002000H–00EFFFH	–	–	–
1	0	32K bytes	002000H–007FFFH	008000H–00EFFFH	–	–
0	1	16K bytes	002000H–003FFFH	004000H–007FFFH	008000H–00BFFFH	00C000H–00EFFFH
0	0	8K bytes	008000H–009FFFH	002000H–003FFFH	004000H–005FFFH	006000H–007FFFH

(3) Expanded 64K mode + MPU mode (E0C88348/317/316/308)

CEMD1	CEMD0	Chip size	$\overline{CE0}$	$\overline{CE1}$	$\overline{CE2}$	$\overline{CE3}$
1	1	64K bytes	000000H–00EFFFH	–	–	–
1	0	32K bytes	000000H–007FFFH	008000H–00EFFFH	–	–
0	1	16K bytes	000000H–003FFFH	004000H–007FFFH	008000H–00BFFFH	00C000H–00EFFFH
0	0	8K bytes	000000H–001FFFH	002000H–003FFFH	004000H–005FFFH	006000H–007FFFH

(4) Expanded 512K minimum/maximum modes (E0C88348/317/316/308)

$\overline{CE}$ signal	Address range	
	MCU mode	MPU mode
$\overline{CE0}$	200000H–27FFFH	000000H–00EFFFH, 010000H–07FFFH
$\overline{CE1}$	080000H–0FFFFH	080000H–0FFFFH
$\overline{CE2}$	100000H–17FFFH	100000H–17FFFH
$\overline{CE3}$	180000H–1FFFFH	180000H–1FFFFH

Notes: • "Expanded 64K mode + MCU mode" cannot be selected in the E0C88348/317.

- The  $\overline{CE}$  terminal status when the HALT or SLP instruction is executed in the external program memory is different depending on the model as follows:

**E0C88348/317**

The  $\overline{CE}$  terminal goes HIGH when the CPU enters HALT or SLEEP status.

**E0C88316/88308**

The  $\overline{CE}$  terminal does not change its status when the CPU enters HALT or SLEEP status, so the external ROM access status will be maintained.

### 5.2.3 WAIT state settings

In order to insure accessing of external low speed devices during high speed operations, the E0C883xx is equipped with a WAIT function which prolongs access time.

The number of wait states inserted can be selected from a choice of eight as shown in Table 5.2.3.1 by means of registers WT0–WT2.

Table 5.2.3.1 Setting the number of WAIT states

WT2	WT1	WT0	Number of inserted states
1	1	1	14
1	1	0	12
1	0	1	10
1	0	0	8
0	1	1	6
0	1	0	4
0	0	1	2
0	0	0	No wait

\* A state is 1/2 cycles of the clock in length.

WAIT states set in software are inserted between bus cycle states T3–T4.

Note, however, that WAIT states cannot be inserted when an internal register and internal memory are being accessed and when operating with the OSC1 oscillation circuit (see "5.4 Oscillation Circuits and Operating Mode").

Consequently, WAIT state settings in single chip mode are meaningless.

With regard to WAIT insertion timing, see Section 3.6.5, "WAIT control".

### 5.2.4 Setting the bus authority release request signal

With systems performing DMA transfer, the bus authority release request signal ( $\overline{\text{BREQ}}$ ) input terminal and acknowledge signal ( $\overline{\text{BACK}}$ ) output terminal have to be set.

The  $\overline{\text{BREQ}}$  input terminal is shared with input port terminal K11 and the  $\overline{\text{BACK}}$  output terminal with output port terminal R51. At initial reset, these terminal facilities are set as input port terminal and output port terminal, respectively. The terminals can be altered to function as  $\overline{\text{BREQ}}$ / $\overline{\text{BACK}}$  terminals by writing a "1" to register EBR.

Since there is no bus authority release function in the E0C88308, register EBR in the E0C88308 is usable as a general purpose register with read/write capabilities.

For details on bus authority release, see "3.6.6 Bus authority release state" and "E0C88 Core CPU Manual".

### 5.2.5 Stack page setting

Although the stack area used to evacuate registers during subroutine calls can be arbitrarily moved to any area in data RAM using the stack pointer SP, its page address is set in registers SPP0–SPP7 in I/O memory.

At initial reset, SPP0–SPP7 are set to "00H" (page 0).

Since the internal RAM is arranged on page 0 (E0C88348/317/316: 00F000H–00F7FFH, E0C88308: 00F000H–00F0FFH), the stack area in single chip mode is inevitably located in page 0.

In expanded 64K mode where RAM is externally expanded, stack page is likewise limited to page 0. In order to place the stack area at the final address in internal RAM, the stack pointer SP is placed at an initial setting of "F800H" (E0C88348/317/316) or "F100H" (E0C88308). (SP is pre-decremented.)

In the expanded 512K mode, to place the stack in external expanded RAM, set a corresponding page to SPP0–SPP7. The page addresses to which SPP0–SPP7 can be set are 00H–27H and must be within a RAM area.

\* A page is each recurrent 64K division of data memory beginning at address zero.

## 5.2.6 Control of system controller

Table 5.2.6.1 shows the control bits for the system controller.

Table 5.2.6.1(a) System controller control bits (MCU mode)

Address	Bit	Name	Function	1	0	SR	R/W	Comment	
00FF00 (MCU)	D7	BSMD1	Bus mode (CPU mode) <u>BSMD1 BSMD0 Mode</u> 1 1 512K (Maximum)			0	R/W		
	D6	BSMD0	1 0 512K (Minimum) 0 1 64K 0 0 Single chip			0	R/W		
	D5	CEMD1	Chip enable mode <u>CEMD1 CEMD0 Mode</u> 1 1 64K ( $\overline{CE0}$ ) 1 0 32K ( $\overline{CE0}$ , $\overline{CE1}$ )			1	R/W	Only for 64K bus mode *1	
	D4	CEMD0	0 1 16K ( $\overline{CE0}$ – $\overline{CE3}$ ...E0C88308) 0 0 8K ( $\overline{CE1}$ – $\overline{CE3}$ ...E0C88316)			1	R/W		
	D3	CE3	$\overline{CE3}$ (R33)	$\overline{CE}$ signal output Enable/Disable	$\overline{CE3}$ enable	$\overline{CE3}$ disable	0	R/W	In the Single chip mode, these setting are fixed at DC output.
	D2	CE2	$\overline{CE2}$ (R32)	Enable: $\overline{CE}$ signal output	$\overline{CE2}$ enable	$\overline{CE2}$ disable	0	R/W	
	D1	CE1	$\overline{CE1}$ (R31)	Disable: DC (R3x) output	$\overline{CE1}$ enable	$\overline{CE1}$ disable	0	R/W	
	D0	CE0	$\overline{CE0}$ (R30)		$\overline{CE0}$ enable	$\overline{CE0}$ disable	0	R/W	
00FF01	D7	SPP7	Stack pointer page address (MSB)	1	0	0	R/W		
	D6	SPP6		1	0	0	R/W		
	D5	SPP5	< SP page allocatable address >	1	0	0	R/W		
	D4	SPP4	• Single chip mode: only 0 page	1	0	0	R/W		
	D3	SPP3	• 64K mode: only 0 page	1	0	0	R/W		
	D2	SPP2	• 512K (min) mode: 0–27H page	1	0	0	R/W		
	D1	SPP1	• 512K (max) mode: 0–27H page	1	0	0	R/W		
	D0	SPP0	(LSB)	1	0	0	R/W		
00FF02	D7	EBR	Bus release enable register (K11 and R51 terminal specification)	K11 $\overline{BREQ}$ R51 BACK	Input port Output port	0	R/W	*2	
	D6	WT2	Wait control register <u>WT2 WT1 WT0 Number of state</u> 1 1 1 14 1 1 0 12						
	D5	WT1	1 0 1 10 1 0 0 8 0 1 1 6			0	R/W		
	D4	WT0	0 1 0 4 0 0 1 2 0 0 0 No wait						
	D3	CLKCHG	CPU operating clock switch	OSC3	OSC1	0	R/W		
	D2	OSCC	OSC3 oscillation On/Off control	On	Off	0	R/W		
	D1	VDC1	Operating mode selection <u>VDC1 VDC0 Operating mode</u> 1 × High speed ( $V_{D1}$ =3.3V)			0	R/W		
	D0	VDC0	0 1 Low power ( $V_{D1}$ =1.3V) 0 0 Normal ( $V_{D1}$ =2.2V)						

\*1 This is just R/W register on E0C88348/317. \*2 This is just R/W register on E0C88308.

Note: All the interrupts including  $\overline{NMI}$  are disabled, until you write the optional value into both the "00FF00H" and "00FF01H" addresses.

Table 5.2.6.1(b) System controller control bits (MPU mode)

Address	Bit	Name	Function	1	0	SR	R/W	Comment				
00FF00 (MPU)	D7	BSMD1	Bus mode (CPU mode) BSMD1 BSMD0 Mode 1 1 512K (Maximum)			*	R/W	* Initial setting can be selected among 3 types (64K, 512K min and 512K max) by mask option setting.				
	D6	BSMD0	1 0 512K (Minimum)				R/W					
			0 1 64K									
	D5	CEMD1	Chip enable mode CEMD1 CEMD0 Mode 1 1 64K (CE0)							1	R/W	Only for 64K bus mode
			1 0 32K (CE0, CE1)							1	R/W	
	D4	CEMD0	0 1 16K (CE0-CE3)									
			0 0 8K (CE0-CE3)									
	D3	CE3	CE3 (R33)				CE3 enable		CE3 disable	0	R/W	
D2	CE2	CE2 (R32)	CE2 enable	CE2 disable	0	R/W						
D1	CE1	CE1 (R31)	CE1 enable	CE1 disable	0	R/W						
D0	CE0	CE0 (R30)	CE0 enable	CE0 disable	1	R/W						
00FF01	D7	SPP7	Stack pointer page address (MSB)	1	0	0	R/W					
	D6	SPP6		1	0	0	R/W					
	D5	SPP5	< SP page allocatable address >	1	0	0	R/W					
	D4	SPP4	• Single chip mode: only 0 page	1	0	0	R/W					
	D3	SPP3	• 64K mode: only 0 page	1	0	0	R/W					
	D2	SPP2	• 512K (min) mode: 0-27H page	1	0	0	R/W					
	D1	SPP1	• 512K (max) mode: 0-27H page	1	0	0	R/W					
	D0	SPP0	(LSB)	1	0	0	R/W					
00FF02	D7	EBR	Bus release enable register (K11 and R51 terminal specification)	$\overline{\text{BREQ}}$ BACK	Input port Output port	0	R/W	*1				
	D6	WT2	Wait control register WT2 WT1 WT0 Number of state 1 1 1 14									
			1 1 0 12									
	D5	WT1	1 0 1 10									
			0 1 1 8									
	D4	WT0	0 1 1 6									
			0 1 0 4									
			0 0 1 2									
		0 0 0 No wait										
D3	CLKCHG	CPU operating clock switch	OSC3	OSC1	0	R/W						
D2	OSCC	OSC3 oscillation On/Off control	On	Off	0	R/W						
D1	VDC1	Operating mode selection VDC1 VDC0 Operating mode 1 × High speed (VD1=3.3V)			0	R/W						
		0 1 Low power (VD1=1.3V)										
D0	VDC0	0 0 Normal (VD1=2.2V)										

\*1 This is just R/W register on E0C88308.

Note: All the interrupts including  $\overline{\text{NMI}}$  are disabled, until you write the optional value into both the "00FF00H" and "00FF01H" addresses.

**BSMD0, BSMD1: 00FF00H•D6, D7**

Bus modes are set as shown in Table 5.2.6.2.

Table 5.2.6.2 Bus mode settings

Setting values		Bus mode
BSMD1	BSMD0	
1	1	Expanded 512K maximum mode
1	0	Expanded 512K minimum mode
0	1	Expanded 64K mode
0	0	Single chip mode (MCU) ----- Optional setting of one of the expanded modes (MPU)

The single chip mode setting is only possible when this IC is used in the MCU mode. The single chip mode setting is incompatible with the MPU mode, since this mode does not utilize internal ROM. When using in the MPU mode, it is necessary to select the bus mode at the time of the initial resetting and at the time of the <BSMD1 = "0" and BSMD0 = "0"> setting from among the three types of expanded modes (expanded 64K mode, expanded 512K minimum mode and expanded 512K maximum mode) by mask option. Select the expanded 512K maximum mode for this option, when the MPU mode is not used at all. At initial reset, in the MCU mode the unit is set to single chip mode and in the MPU mode the mask option is used to select the applicable mode.

**CEMD0, CEMD1: 00FF00H•D4, D5**

Sets the  $\overline{CE}$  signal address range (valid only in the expanded 64K mode).

Settings are made according to external memory chip size as shown in Table 5.2.6.3.

Table 5.2.6.3  $\overline{CE}$  signal settings

CEMD1	CEMD0	Address range	Usable terminals
1	1	64K bytes	$\overline{CE0}$
1	0	32K bytes	$\overline{CE0}, \overline{CE1}$
0	1	16K bytes	$\overline{CE0}-\overline{CE3}$ $\overline{CE1}-\overline{CE3}..E0C88316$ *
0	0	8K bytes	$\overline{CE0}-\overline{CE3}$

\* At the case of MPU mode,  $\overline{CE0}-\overline{CE3}$ .

These settings are invalid for any mode other than expanded 64K mode. At initial reset, each register is set to "1" (64K bytes).

**CE0-CE3: 00FF00H•D0-D3**

Sets the  $\overline{CE}$  output terminals being used.

When "1" is written:  $\overline{CE}$  output enable  
 When "0" is written:  $\overline{CE}$  output disable  
 Reading: Valid

$\overline{CE}$  output is enabled when a "1" is written to registers CE0-CE3 which correspond to the  $\overline{CE}$  output being used. A "0" written to any of the registers disables  $\overline{CE}$  signal output from that terminal and it reverts to its alternate function as an output port terminal (R30-R33).

At initial reset, register CE0 is set to "0" in the MCU mode and in the MPU mode, "1" is set in the register. Registers CE1-CE3 are always set to "0" regardless of the MCU/MPU mode setting.

*Note: To avoid a malfunction from an interrupt generated before the bus configuration is initialized, all interrupts including  $\overline{NMI}$  are masked until you write an optional value into address "00FF00H".*

**SPP0-SPP7: 00FF01H**

Sets the page address of stack area. In single chip mode and expanded 64K mode, set page address to "00H".

In expanded 512K mode, it can be set to any value within the range "00H"- "27H".

Since a carry and borrow from/to the stack pointer SP is not reflected in register SPP, the upper limit on continuous use of the stack area is 64K bytes.

At initial reset, this register is set to "00H" (page 0).

*Note: To avoid a malfunction from an interrupt generated before the bus configuration is initialized, all interrupts including  $\overline{NMI}$  are disabled, until you write an optional value into "00FF01H" address. Furthermore, to avoid generating an interrupt while the stack area is being set, all interrupts including  $\overline{NMI}$  are disabled in one instruction execution period after writing to address "00FF01H".*



**WT0–WT2: 00FF02H•D4–D6**

How WAIT state settings are performed.  
The number of WAIT states to be inserted based on register settings is as shown in Table 5.2.6.4.

Table 5.2.6.4 Setting WAIT states

WT2	WT1	WT0	No. of inserted states
1	1	1	14
1	1	0	12
1	0	1	10
1	0	0	8
0	1	1	6
0	1	0	4
0	0	1	2
0	0	0	No wait

\* A state is 1/2 cycles of the clock in length.

At initial reset, this register is set to "0" (no wait).

**EBR: 00FF02H•D7**

Sets the  $\overline{\text{BREQ}}$ / $\overline{\text{BACK}}$  terminals function.

When "1" is written:  $\overline{\text{BREQ}}$ / $\overline{\text{BACK}}$  enabled

When "0" is written:  $\overline{\text{BREQ}}$ / $\overline{\text{BACK}}$  disabled

Reading: Valid

How  $\overline{\text{BREQ}}$  and  $\overline{\text{BACK}}$  terminal functions are set.  
Writing "1" to EBR enables  $\overline{\text{BREQ}}$ / $\overline{\text{BACK}}$  input/output. Writing "0" sets the  $\overline{\text{BREQ}}$  terminal as input port terminal K11 and the  $\overline{\text{BACK}}$  terminal as output port terminal R51.

At initial reset, EBR is set to "0" ( $\overline{\text{BREQ}}$ / $\overline{\text{BACK}}$  disabled).

**5.2.7 Programming notes**

(1) All the interrupts including  $\overline{\text{NMI}}$  are masked, until you write the optional value into both the "00FF00H" and "00FF01H" addresses. Consequently, even if you do not change the content of this address (You use the initial value, as is.), you should still be sure to perform the writing operation using the initialization routine.

(2) When setting stack fields, including page addresses as well, you should write them in the order of the register SPP ("00FF01H") and the stack pointer SP.

Example: When setting the "178000H" address

```
LD EP, #00H
```

```
LD HL, #0FF01H
```

```
LD [HL], #17H
```

```
LD SP, #8000H
```

During this period the interrupts (including  $\overline{\text{NMI}}$ ) are masked.

### 5.3 Watchdog Timer

#### 5.3.1 Configuration of watchdog timer

The E0C883xx is equipped with a watchdog timer driven by OSC1 as source oscillation. The watchdog timer must be reset periodically in software, and if reset of more than 3–4 seconds (when fOSC1 = 32.768 kHz) does not take place, a non-maskable interrupt signal is generated and output to the CPU.

Figure 5.3.1.1 is a block diagram of the watchdog timer.

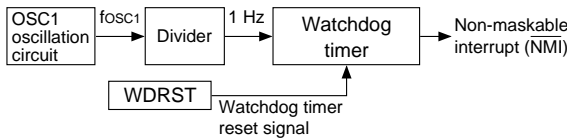

Fig. 5.3.1.1 Block diagram of watchdog timer

By running watchdog timer reset during the main routine of the program, it is possible to detect program runaway as if watchdog timer processing had not been applied. Normally, this routine is integrated at points that are regularly being processed.

The watchdog timer continues to operate during HALT and when a HALT state is continuous for longer than 3–4 seconds, the CPU shifts to exception processing.

During SLEEP, the watchdog timer is stopped.

#### 5.3.2 Interrupt function

In cases where the watchdog timer is not periodically reset in software, the watchdog timer outputs an interrupt signal to the CPU's  $\overline{\text{NMI}}$  (level 4) input. Unmaskable and taking priority over other interrupts, this interrupt triggers the generation of exception processing. See the "E0C88 Core CPU Manual" for more details on  $\overline{\text{NMI}}$  exception processing.

This exception processing vector is set at 000004H.

#### 5.3.3 Control of watchdog timer

Table 5.3.3.1 shows the control bits for the watchdog timer.

##### WDRST: 00FF40H•D2

Resets the watchdog timer.

- When "1" is written: Watchdog timer is reset
- When "0" is written: No operation
- Reading: Constantly "0"

By writing "1" to WDRST, the watchdog timer is reset, after which it is immediately restarted.

Writing "0" will mean no operation.

Since WDRST is for writing only, it is constantly set to "0" during readout.

#### 5.3.4 Programming notes

- (1) The watchdog timer must reset within 3-second cycles by software.
- (2) Do not execute the SLP instruction for 2 msec after a  $\overline{\text{NMI}}$  interrupt has occurred (when fOSC1 is 32.768 kHz).

Table 5.3.3.1 Watchdog timer control bits

Address	Bit	Name	Function	1	0	SR	R/W	Comment	
00FF40	D7	–	–	–	–	–	–	"0" when being read	
	D6	FOUT2	FOUT frequency selection				0	R/W	
			<u>FOUT2</u>	<u>FOUT1</u>	<u>FOUT0</u>	<u>Frequency</u>			
			0	0	0	fOSC1 / 1			
			0	0	1	fOSC1 / 2			
	D5	FOUT1	0	1	0	fOSC1 / 4	0	R/W	
			0	1	1	fOSC1 / 8			
			1	0	0	fOSC3 / 1			
	D4	FOUT0	1	0	1	fOSC3 / 2	0	R/W	
			1	1	0	fOSC3 / 4			
1			1	1	fOSC3 / 8				
D3	FOUTON	FOUT output control		On	Off	0	R/W		
D2	WDRST	Watchdog timer reset		Reset	No operation	–	W	Constantly "0" when	
D1	TMRST	Clock timer reset		Reset	No operation	–	W	being read	
D0	TMRUN	Clock timer Run/Stop control		Run	Stop	0	R/W		

## 5.4 Oscillation Circuits and Operating Mode

### 5.4.1 Configuration of oscillation circuits

The E0C883xx is twin clock system with two internal oscillation circuits (OSC1 and OSC3). OSC1 oscillation circuit generates the 32.768 kHz (Typ.) main clock and OSC3 oscillation circuit the sub-clock when the CPU and some peripheral circuits (output port, serial interface and programmable timer) are in high speed operation. Figure 5.4.1.1 shows the configuration of the oscillation circuit.

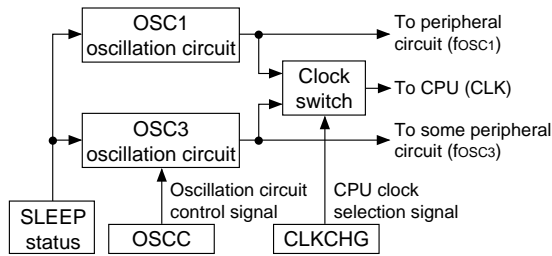

Fig. 5.4.1.1 Configuration of oscillation circuits

At initial reset, OSC1 oscillation circuit is selected for the CPU operating clock and OSC3 oscillation circuit is in a stopped state. ON/OFF switching of the OSC3 oscillation circuit and switching of the system clock between OSC1 and OSC3 are controlled in software. OSC3 circuit is utilized when high speed operation of the CPU and some peripheral circuits become necessary. Otherwise, OSC1 should be used to generate the operating clock and OSC3 circuit placed in a stopped state in order to reduce current consumption.

### 5.4.2 Mask option

#### OSC1 oscillation circuit

- Crystal oscillation circuit
- External clock input
- CR oscillation circuit
- Crystal oscillation circuit (gate capacitor built-in)

#### OSC3 oscillation circuit

- Crystal oscillation circuit
- Ceramic oscillation circuit
- CR oscillation circuit
- External clock input

In terms of the oscillation circuit types for OSC1, either crystal oscillation, CR oscillation, crystal oscillation (gate capacitor built-in) or external clock input can be selected with the mask option.

In terms of oscillation circuit types for OSC3, either crystal oscillation, ceramic oscillation, CR oscillation or external clock input can be selected with the mask option, in the same way as OSC1.

### 5.4.3 OSC1 oscillation circuit

The OSC1 oscillation circuit generates the 32.768 kHz (Typ.) system clock which is utilized during low speed operation (low power mode) of the CPU and peripheral circuits. Furthermore, even when OSC3 is utilized as the system clock, OSC1 continues to generate the source clock for the clock timer and stopwatch timer.

This oscillation circuit stops when the SLP instruction is executed. However, in case the SVD circuit is executing an SLP instruction, oscillation is stopped in synchronization with the completion of sampling. In terms of the oscillation circuit types, either crystal oscillation, CR oscillation, crystal oscillation (gate capacitor built-in) or external clock input can be selected with the mask option.

Figure 5.4.3.1 shows the configuration of the OSC1 oscillation circuit.

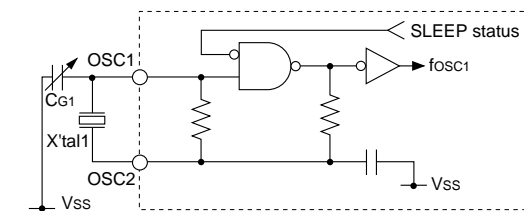

(1) Crystal oscillation circuit

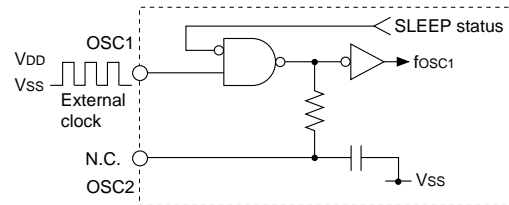

(2) External clock input

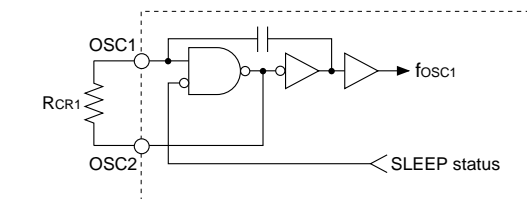

(3) CR oscillation circuit

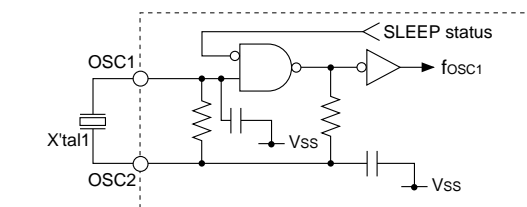

(4) Crystal oscillation circuit

Fig. 5.4.3.1 OSC1 oscillation circuit (gate capacitor built-in)

When crystal oscillation is selected, a crystal oscillation circuit can be easily formed by connecting a crystal oscillator X'tal1 (Typ. 32.768 kHz) between the OSC1 and OSC2 terminals along with a trimmer capacitor CG1 (5–25 pF) between the OSC1 terminal and Vss.

In addition, the gate capacitor CG1 (5 pF) can be built into the circuit by the mask option.

When CR oscillation is selected, connect a resistor (RCR1) between the OSC1 and OSC2 terminals.

When external input is selected, release the OSC2 terminal and input the rectangular wave clock into the OSC1 terminal.

### 5.4.4 OSC3 oscillation circuit

The OSC3 oscillation circuit generates the system clock when the CPU and some peripheral circuits (output port, serial interface and programmable timer) are in high speed operation.

This oscillation circuit stops when the SLP instruction is executed, or the OSCC register is set to "0". In terms of oscillation circuit types, any one of crystal oscillation, ceramic oscillation, CR oscillation or external clock input can be selected with the mask option.

Figure 5.4.4.1 shows the configuration of the OSC3 oscillation circuit.

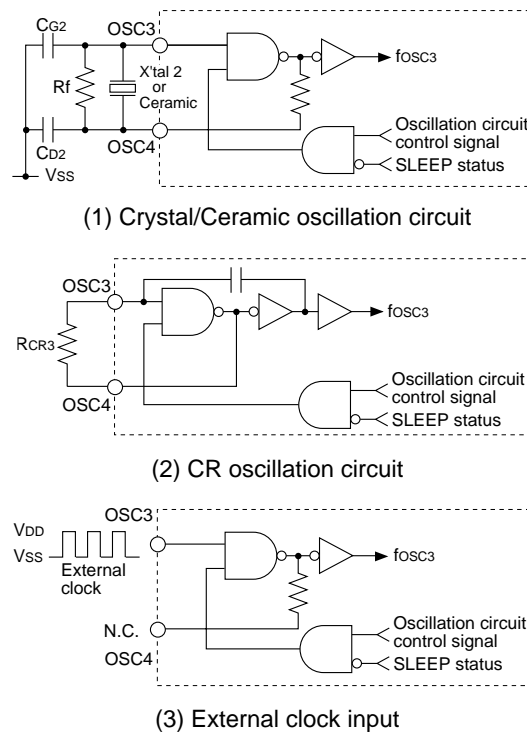

Fig. 5.4.4.1 OSC3 oscillation circuit

When crystal or ceramic oscillation circuit is selected, the crystal or ceramic oscillation circuit are formed by connecting either a crystal oscillator (X'tal2) or a combination of ceramic oscillator (Ceramic) and feedback resistor (Rf) between OSC3 and OSC4 terminals and connecting two capacitors (CG2, CD2) between the OSC3 terminal and Vss, and between the OSC4 terminal and Vss, respectively.

When CR oscillation is selected, the CR oscillation circuit is formed merely by connecting a resistor (RCR3) between OSC3 and OSC4 terminals.

When external input is selected, release the OSC4 terminal and input the rectangular wave clock into the OSC3 terminal.

### 5.4.5 Operating mode

You can select three types of operating modes using software, to obtain a stable operation and good characteristics (operating frequency and current consumption) over a broad operation voltage. Here below are indicated the features of the respective modes.

- Normal mode (VDD = 2.4 V–5.5 V)**  
 This mode is set following the initial reset. It permits the OSC3 oscillation circuit (Max. 4.2 MHz) to be used and also permits relative low power operation.
- Low power mode (VDD = 1.8 V–3.5 V)**  
 This is a lower power mode than the normal mode. It makes ultra-low power consumption possible by operation on the OSC1 oscillation circuit, although the OSC3 circuit cannot be used.
- High speed mode (VDD = 3.5 V–5.5 V)**  
 This mode permits higher speed operation than the normal mode. Since the OSC3 oscillation circuit (Max. 8.2 MHz) can be used, you should use this mode, when you require operation at 4.2 MHz or more. However, the current consumption will increase relative to the normal mode.

Using software to switch over among the above three modes to meet your actual usage circumstances will make possible a low power system. For example, you will be able to reduce current consumption by switching over to the normal mode when using the OSC3 as the CPU clock and, conversely, changing over to the low power mode when using the OSC1 as the CPU clock (OSC3 oscillation circuit is OFF).

**Note:** Do not turn the OSC3 oscillation circuit ON in the low power mode.

Do not switch over the operating mode (normal mode ↔ high speed mode) in the OSC3 oscillation circuit ON status, as this will cause faulty operation.

You can not use two modes, the low power mode and the high speed mode on one application, with respect to the operating voltages.

When CR oscillation is selected for the OSC1 oscillation circuit, the operating mode is fixed in the normal mode to stabilize the oscillation frequency. Consequently, settings of the mode setting registers VDC0 and VDC1 become invalid.

### 5.4.6 Switching the CPU clocks

You can use either OSC1 or OSC3 as the system clock for the CPU and you can switch over by means of software.

You can save power by turning the OSC3 oscillation circuit off while the CPU is operating in OSC1.

When you must operate on OSC3, you can change to high speed operation by turning the OSC3 oscillation circuit ON and switching over the system clock. In this case, since several msec to several tens of msec are necessary for the oscillation to stabilize after turning the OSC3 oscillation circuit ON, you should switch over the clock after stabilization time has elapsed. (The oscillation start time will vary somewhat depending on the oscillator and on the externally attached parts. Refer to the oscillation start time example indicated in Chapter 7, "ELECTRICAL CHARACTERISTICS".)

When switching over from the OSC3 to the OSC1, turn the OSC3 oscillation circuit OFF immediately following the clock changeover. The basic clock switching procedure is as described above, however, you must also combine it with the changeover of the operating mode to permit low current consumption and high speed operation.

Figure 5.4.6.1 indicates the status transition diagram for the operation mode and clock changeover.

**Note:** When turning ON the OSC3 oscillation circuit after switching the operating mode, you should allow a minimum waiting time of 5 msec.

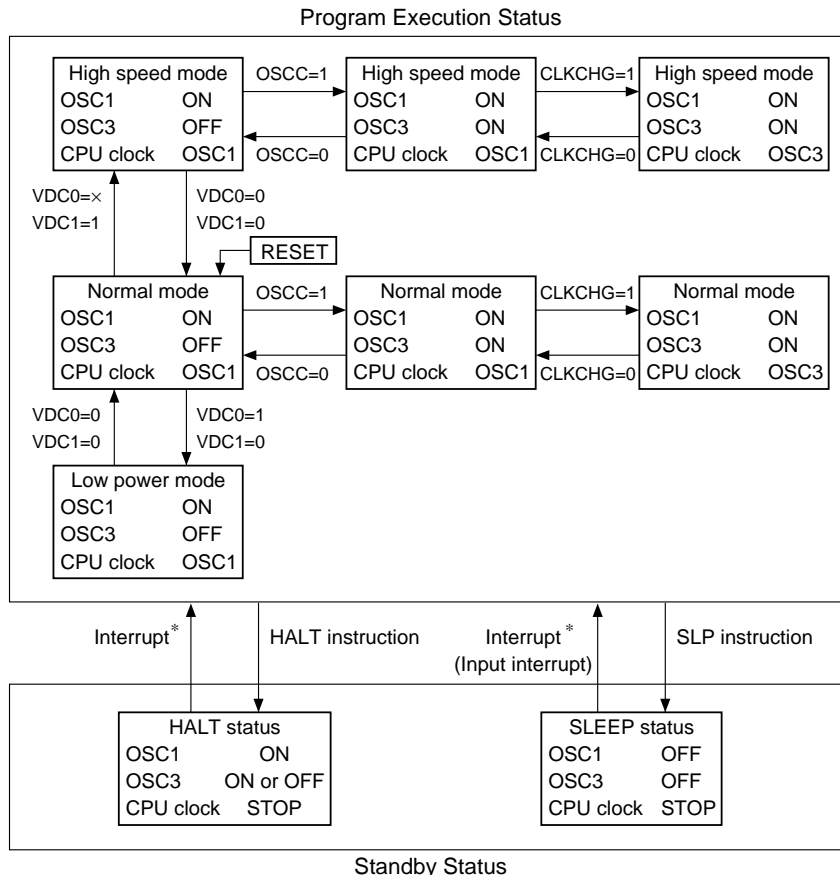

Fig. 5.4.6.1  
Status transition diagram for the operation mode and clock changeover

\* The return destination from the standby status becomes the program execution status prior to shifting to the standby status

### 5.4.7 Control of oscillation circuit and operating mode

Table 5.4.7.1 shows the control bits for the oscillation circuits and operating modes.

Table 5.4.7.1 Oscillation circuit and operating mode control bits

Address	Bit	Name	Function	1	0	SR	R/W	Comment				
00FF02	D7	EBR	Bus release enable register (K11 and R51 terminal specification)	K11 BREQ R51 BACK	Input port Output port	0	R/W	*1				
	D6	WT2	Wait control register	Number of state								
									WT2	WT1	WT0	
	D5	WT1					0	R/W	1	1	0	14
									1	0	1	12
									1	0	0	10
									0	1	1	8
	D4	WT0							0	1	0	6
									0	1	0	4
									0	0	1	2
			0	0	0	No wait						
D3	CLKCHG	CPU operating clock switch		OSC3	OSC1	0	R/W					
D2	OSCC	OSC3 oscillation On/Off control		On	Off	0	R/W					
D1	VDC1	Operating mode selection	Operating mode			0	R/W	VDC1	VDC0			
								1	×	High speed (VD1=3.3V)		
								0	1	Low power (VD1=1.3V)		
D0	VDC0							0	0	Normal (VD1=2.2V)		

\*1 This is just R/W register on E0C88308.

#### VDC1, VDC0: 00FF02H•D1, D0

Selects the operating mode according to supply voltage and operating frequency. Table 5.4.7.2 shows the correspondence between register preset values and operating modes.

Table 5.4.7.2 Correspondence between register preset values and operating modes

Operating mode	VDC1	VDC0	VD1	Power voltage	Operating frequency
Normal mode	0	0	2.2 V	2.4–5.5 V	4.2 MHz (Max.)
Low power mode	0	1	1.3 V	1.8–3.5 V	50 kHz (Max.)
High speed mode	1	×	3.3 V	3.5–5.5 V	8.2 MHz (Max.)

\* The VD1 voltage is the value where VSS has been made the standard (GND).

At initial reset, this register is set to "0" (normal mode).

#### OSCC: 00FF02H•D2

Controls the ON and OFF settings of the OSC3 oscillation circuit.

When "1" is written: OSC3 oscillation ON  
 When "0" is written: OSC3 oscillation OFF  
 Reading: Valid

When the CPU and some peripheral circuits (output port, serial interface and programmable timer) are to be operated at high speed, OSCC is to be set to "1". At all other times, it should be set to "0" in order to reduce current consumption. At initial reset, OSCC is set to "0" (OSC3 oscillation OFF).

#### CLKCHG: 00FF02H•D3

Selects the operating clock for the CPU.

When "1" is written: OSC3 clock  
 When "0" is written: OSC1 clock  
 Reading: Valid

When the operating clock for the CPU is switched to OSC3, CLKCHG should be set to "1" and when the clock is switched to OSC1, CLKCHG should be set to "0". At initial reset, CLKCHG is set to "0" (OSC1 clock).

### 5.4.8 Programming notes

- (1) When the high speed CPU operation is not necessary, you should operate the peripheral circuits according to the setting outline indicate below.
  - CPU operating clock  
OSC1
  - OSC3 oscillation circuit  
OFF (When the OSC3 clock is not necessary for some peripheral circuits.)
  - Operating mode  
Low power mode (When  $V_{DD}-V_{SS}$  is 3.5 V or less)  
or Normal mode (When  $V_{DD}-V_{SS}$  is 3.5 V or more)
- (2) Do not turn the OSC3 oscillation circuit ON in the low power mode.  
Do not switch over the operating mode (normal mode ↔ high speed mode) in the OSC3 oscillation circuit ON status, as this will cause faulty operation.
- (3) When turning ON the OSC3 oscillation circuit after switching the operating mode, you should allow a minimum waiting time of 5 msec.
- (4) Since several msec to several tens of msec are necessary for the oscillation to stabilize after turning the OSC3 oscillation circuit ON. Consequently, you should switch the CPU operating clock (OSC1 → OSC3) after allowing for a sufficient waiting time once the OSC3 oscillation goes ON. (The oscillation start time will vary somewhat depending on the oscillator and on the externally attached parts. Refer to the oscillation start time example indicated in Chapter 7, "ELECTRICAL CHARACTERISTICS".)
- (5) When switching the clock from OSC3 to OSC1, be sure to switch OSC3 oscillation OFF with separate instructions. Using a single instruction to process simultaneously can cause a malfunction of the CPU.

## 5.5 Input Ports (K ports)

### 5.5.1 Configuration of input ports

The E0C88348/317/316 is equipped with 10 input port bits (K00–K07, K10 and K11) and the E0C88308 is equipped with 9 input port bits (K00–K07, K10) all of which are usable as general purpose input port terminals with interrupt function.

K10 terminal doubles as the external clock (EVIN) input terminal of the programmable timer (event counter) with input port functions sharing the input signal as is. (See "5.11 Programmable Timer")

Furthermore, it should be noted, however, that K11 terminal (K11 is not available in the E0C88308) is shared with the bus authority release request signal (BREQ) input terminal. Function assignment of this terminal can be selected in software. When this terminal is selected for BREQ signal, K11 cannot be used as an input port. (See "5.2 System Controller and Bus Control")

In the explanation below, it is assumed that K11 is set as an input port.

Each input port is equipped with a pull-up resistor. The mask option can be used to select either "With resistor" or "Gate direct" for each input port.

Figure 5.5.1.1 shows the structure of the input port.

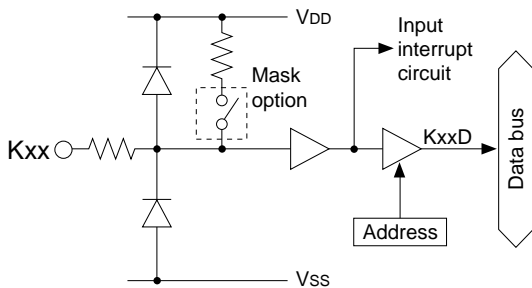

Fig. 5.5.1.1 Structure of input port

Each input port terminal is directly connected via a three-state buffer to the data bus. Furthermore, the input signal state at the instant of input port readout is read in that form as data.

### 5.5.2 Mask option

#### Input port pull-up resistors

K00 ....	<input type="checkbox"/> With resistor	<input type="checkbox"/> Gate direct
K01 ....	<input type="checkbox"/> With resistor	<input type="checkbox"/> Gate direct
K02 ....	<input type="checkbox"/> With resistor	<input type="checkbox"/> Gate direct
K03 ....	<input type="checkbox"/> With resistor	<input type="checkbox"/> Gate direct
K04 ....	<input type="checkbox"/> With resistor	<input type="checkbox"/> Gate direct
K05 ....	<input type="checkbox"/> With resistor	<input type="checkbox"/> Gate direct
K06 ....	<input type="checkbox"/> With resistor	<input type="checkbox"/> Gate direct
K07 ....	<input type="checkbox"/> With resistor	<input type="checkbox"/> Gate direct
K10 ....	<input type="checkbox"/> With resistor	<input type="checkbox"/> Gate direct
K11 ....	<input type="checkbox"/> With resistor	<input type="checkbox"/> Gate direct

\* K11 is not available in the E0C88308

Input ports K00–K07, K10 and K11 (K11 is not available in the E0C88308) are all equipped with pull-up resistors. The mask option can be used to select 'With resistor' or 'Gate direct' for each port (bit).

The 'With resistor' option is rendered suitable for purposes such as push switch or key matrix input. When changing the input terminal from LOW level to HIGH with the built-in pull-up resistor, a delay in the waveform rise time will occur depending on the time constant of the pull-up resistor and the load capacitance of the terminal. It is necessary to set an appropriate wait time for introduction of an input port. In particular, special attention should be paid to key scan for key matrix formation. Make this wait time the amount of time or more calculated by the following expression.

**Wait time =  $R_{IN} \times (C_{IN} + \text{load capacitance on the board}) \times 1.6$  [sec]**

$R_{IN}$ : Pull up resistance Max. value

$C_{IN}$ : Terminal capacitance Max. value

When 'Gate direct' is selected, the pull-up resistor is detached and the port is rendered suitable for purposes such as slide switch input and interfacing with other LSIs.

In this case, take care that a floating state does not occur in input.

For unused input ports, select the default setting of "With resistor".



### 5.5.3 Interrupt function and input comparison register

Input port K00–K07, K10 and K11 (K11 is not available in the E0C88308) are all equipped with an interrupt function. These input ports are divided into three groupings: K00–K03 (K0L), K04–K07 (K0H) and K10–K11 (K1). Furthermore, the interrupt generation condition for each series of terminals can be set by software.

When the interrupt generation condition set for each series of terminals is met, the interrupt factor flag FK0L, FK0H or FK1 corresponding to the applicable series is set at "1" and an interrupt is generated.

Interrupt can be prohibited by setting the interrupt enable registers EK0L, EK0H and EK1 for the corresponding interrupt factor flags.

Furthermore, the priority level for input interrupt can be set at the desired level (0–3) using the interrupt priority registers PK00–PK01 and PK10–PK11 corresponding to each of two groups K0x (K00–K07) and K1x (K10–K11).

For details on the interrupt control registers for the above and on operations subsequent to interrupt generation, see "5.16 Interrupt and Standby Status".

The exception processing vectors for each interrupt factor are set as follows:

- K10 and K11 input interrupt: 00000AH
- K04–K07 input interrupt: 00000CH
- K00–K03 input interrupt: 00000EH

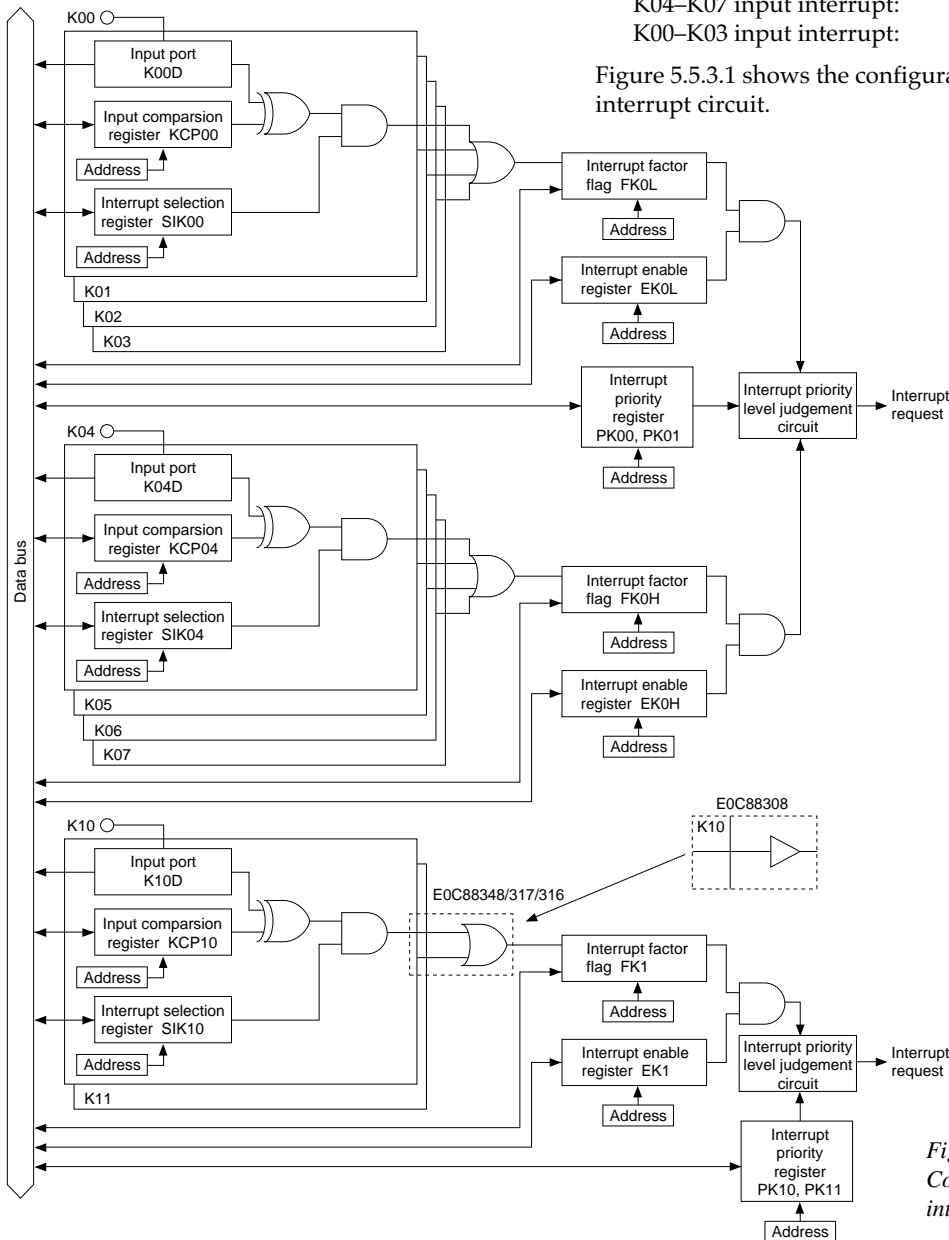

Figure 5.5.3.1 shows the configuration of the input interrupt circuit.

Fig. 5.5.3.1  
Configuration of input interrupt circuit

**5 PERIPHERAL CIRCUITS AND THEIR OPERATION (Input Ports)**

The interrupt selection registers SIK00–SIK03, SIK04–SIK07 and SIK10–SIK11 and input comparison registers KCP00–KCP03, KCP04–KCP07 and KCP10–KCP11 for each port are used to set the interrupt generation condition described above.

Input port interrupt can be permitted or prohibited by the setting of the interrupt selection register SIK. In contrast to the interrupt enable register EK which masks the interrupt factor for each series of terminals, the interrupt selection register SIK masks the bit units.

The input comparison register KCP selects whether the interrupt for each input port will be generated on the rising edge or the falling edge of input.

When the data content of the input terminals in which interrupt has been permitted by the interrupt selection register SIK and the data content of the input comparison register KCP change from a conformity state to a non-conformity state, the interrupt factor flag FK should be set to "1" and an interrupt is generated.

Figure 5.5.3.2 shows an example of interrupt generation in the series of terminals K0L (K00–K03).

Because interrupt has been prohibited for K00 by the interrupt selection register SIK00, with the settings as shown in (2), an interrupt will not be generated.

Since K03 is "0" in the next settings (3) in the figure, the non-conformity between the input terminal data K01–K03 where interrupt is permitted and the data from the input comparison registers KCP01–KCP03 generates an interrupt.

In line with the explanation above, since the change in the contents of input data and input comparison registers KCP from a conformity state to a non-conformity state introduces an interrupt generation condition, switching from one non-conformity state to another, as is the case in (4) in the figure, will not generate an interrupt. Consequently, in order to be able to generate a second interrupt, either the input terminal must be returned to a state where its content is once again in conformity with that of the input comparison register KCP, or the input comparison register KCP must be reset.

Input terminals for which interrupt is prohibited will not influence an interrupt generation condition.

Interrupt is generated in exactly the same way in the other two series of terminals K0H (K04–K07) and K1 (K10 and K11).

(Only K10 belongs to K1 series of the E0C88308)

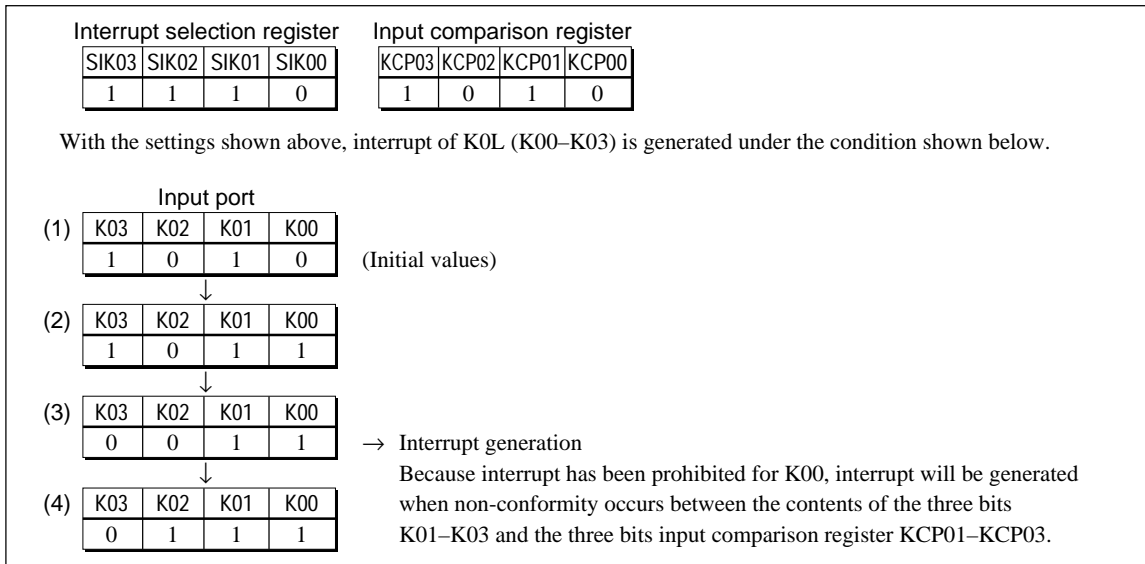

*Fig. 5.5.3.2 Interrupt generation example in K0L (K00–K03)*

### 5.5.4 Control of input ports

Table 5.5.4.1 shows the input port control bits.

Table 5.5.4.1(a) Input port control bits

Address	Bit	Name	Function	1	0	SR	R/W	Comment
00FF50	D7	SIK07	K07 interrupt selection register	Interrupt enable	Interrupt disable	0	R/W	
	D6	SIK06	K06 interrupt selection register					
	D5	SIK05	K05 interrupt selection register					
	D4	SIK04	K04 interrupt selection register					
	D3	SIK03	K03 interrupt selection register					
	D2	SIK02	K02 interrupt selection register					
	D1	SIK01	K01 interrupt selection register					
	D0	SIK00	K00 interrupt selection register					
00FF51	D7	–	–	–	–	–	–	Constantly "0" when being read
	D6	–	–	–	–	–	–	
	D5	–	–	–	–	–	–	
	D4	–	–	–	–	–	–	
	D3	–	–	–	–	–	–	
	D2	–	–	–	–	–	–	
	D1	SIK11	K11 interrupt selection register	Interrupt enable	Interrupt disable	0	R/W	*1
	D0	SIK10	K10 interrupt selection register					
00FF52	D7	KCP07	K07 interrupt comparison register	Interrupt generated at falling edge	Interrupt generated at rising edge	1	R/W	
	D6	KCP06	K06 interrupt comparison register					
	D5	KCP05	K05 interrupt comparison register					
	D4	KCP04	K04 interrupt comparison register					
	D3	KCP03	K03 interrupt comparison register					
	D2	KCP02	K02 interrupt comparison register					
	D1	KCP01	K01 interrupt comparison register					
	D0	KCP00	K00 interrupt comparison register					
00FF53	D7	–	–	–	–	–	–	Constantly "0" when being read
	D6	–	–	–	–	–	–	
	D5	–	–	–	–	–	–	
	D4	–	–	–	–	–	–	
	D3	–	–	–	–	–	–	
	D2	–	–	–	–	–	–	
	D1	KCP11	K11 interrupt comparison register	Falling edge	Rising edge	1	R/W	*2
	D0	KCP10	K10 interrupt comparison register					
00FF54	D7	K07D	K07 input port data	High level input	Low level input	–	R	
	D6	K06D	K06 input port data					
	D5	K05D	K05 input port data					
	D4	K04D	K04 input port data					
	D3	K03D	K03 input port data					
	D2	K02D	K02 input port data					
	D1	K01D	K01 input port data					
	D0	K00D	K00 input port data					
00FF55	D7	–	–	–	–	–	–	Constantly "0" when being read
	D6	–	–	–	–	–	–	
	D5	–	–	–	–	–	–	
	D4	–	–	–	–	–	–	
	D3	–	–	–	–	–	–	
	D2	–	–	–	–	–	–	
	D1	K11D	K11 input port data	High level input	Low level input	–	R	*3
	D0	K10D	K10 input port data					

\*1 Set constantly "0" on E0C88308.

\*3 Constantly "1" when being read on E0C88308.

\*2 Set constantly "1" on E0C88308.

## 5 PERIPHERAL CIRCUITS AND THEIR OPERATION (Input Ports)

Table 5.5.4.1(b) Input port control bits

Address	Bit	Name	Function	1	0	SR	R/W	Comment
00FF20	D7	PK01	K00–K07 interrupt priority register			0	R/W	
	D6	PK00						
	D5	PSIF1	Serial interface interrupt priority register	PK01 PK00 PSIF1 PSIF0 PSW1 PSW0	Priority level	0	R/W	
	D4	PSIF0						
	D3	PSW1	Stopwatch timer interrupt priority register	PTM1 PTM0	Level 3 Level 2	0	R/W	
	D2	PSW0						
D1	PTM1	Clock timer interrupt priority register		Level 1 Level 0	0	R/W		
D0	PTM0							
00FF21	D7	–	–	–	–	–	–	Constantly "0" when being read
	D6	–	–	–	–	–	–	
	D5	–	–	–	–	–	–	
	D4	–	–	–	–	–	–	
	D3	PPT1	Programmable timer interrupt priority register	PPT1 PPT0 PK11 PK10	Priority level	0	R/W	
	D2	PPT0						
D1	PK11	K10 and K11 interrupt priority register		Level 3 Level 2	0	R/W		
D0	PK10							
00FF23	D7	EPT1	Programmable timer 1 interrupt enable register	Interrupt enable	Interrupt disable	0	R/W	
	D6	EPT0	Programmable timer 0 interrupt enable register					
	D5	EK1	K10 and K11 interrupt enable register					
	D4	EK0H	K04–K07 interrupt enable register					
	D3	EK0L	K00–K03 interrupt enable register					
	D2	ESERR	Serial I/F (error) interrupt enable register					
	D1	ESREC	Serial I/F (receiving) interrupt enable register					
D0	ESTRA	Serial I/F (transmitting) interrupt enable register						
00FF25	D7	FPT1	Programmable timer 1 interrupt factor flag	(R)	(R)	0	R/W	
	D6	FPT0	Programmable timer 0 interrupt factor flag	Interrupt factor is generated	No interrupt factor is generated			
	D5	FK1	K10 and K11 interrupt factor flag					
	D4	FK0H	K04–K07 interrupt factor flag					
	D3	FK0L	K00–K03 interrupt factor flag					
	D2	FSERR	Serial I/F (error) interrupt factor flag	(W)	(W)			
	D1	FSREC	Serial I/F (receiving) interrupt factor flag	Reset	No operation			
D0	FSTRA	Serial I/F (transmitting) interrupt factor flag						

### ***K00D–K07D: 00FF54H***

### ***K10D, K11D: 00FF55H•D0, D1***

Input data of input port terminal Kxx can be read out.

When "1" is read: HIGH level  
 When "0" is read: LOW level  
 Writing: Invalid

The terminal voltage of each of the input port K00–K07, K10 and K11 (K11 is not available in the E0C88308) can be directly read out as either a "1" for HIGH (VDD) level or a "0" for LOW (Vss) level. This bit is exclusively for readout and are not usable for write operations.

In the E0C88308, "1" is constantly read out from K11D (00FF55H•D1).

### ***SIK00–SIK07: 00FF50H***

### ***SIK10, SIK11: 00FF51H•D0, D1***

Sets the interrupt generation condition (interrupt permission/prohibition) for input port terminals K00–K07, K10 and K11.

When "1" is written: Interrupt permitted  
 When "0" is written: Interrupt prohibited  
 Reading: Valid

SIKxx is the interrupt selection register which correspond to the input port Kxx. A "1" setting permits interrupt in that input port and a "0" prohibits it. Changes of state in an input terminal in which interrupt is prohibited, will not influence interrupt generation.

At initial reset, this register is set to "0" (interrupt prohibited).

Set constantly "0" for SIK11 (00FF51H•D1) in the E0C88308.

**KCP00–KCP07: 00FF52H****KCP10, KCP11: 00FF53H•D0, D1**

Sets the interrupt generation condition (interrupt generation timing) for input port terminals K00–K07, K10 and K11.

When "1" is written: Falling edge  
 When "0" is written: Rising edge  
 Reading: Valid

KCPxx is the input comparison register which correspond to the input port Kxx. Interrupt in those ports which have been set to "1" is generated on the falling edge of the input and in those set to "0" on the rising edge.

At initial reset, this register is set to "1" (falling edge). Set constantly "1" for KCP11 (00FF53H•D1) in the E0C88308.

**PK00, PK01: 00FF20H•D6, D7****PK10, PK11: 00FF21H•D0, D1**

Sets the input interrupt priority level. The two bits PK00 and PK01 are the interrupt priority registers corresponding to the interrupts for K00–K07 (K0L and K0H). Corresponding to K10–K11 (K1), the two bits PK10 and PK11 perform the same function. Table 5.5.4.2 shows the interrupt priority level which can be set by this register.

Table 5.5.4.2 Interrupt priority level settings

PK11 PK01	PK10 PK00	Interrupt priority level
1	1	Level 3 ( $\overline{IRQ3}$ )
1	0	Level 2 ( $\overline{IRQ2}$ )
0	1	Level 1 ( $\overline{IRQ1}$ )
0	0	Level 0 (None)

At initial reset, this register is set to "0" (level 0).

**EK0L, EK0H, EK1: 00FF23H•D3, D4, D5**

How interrupt generation to the CPU is permitted or prohibited.

When "1" is written: Interrupt permitted  
 When "0" is written: Interrupt prohibited  
 Reading: Valid

The interrupt enable register EK0L corresponds to K00–K03, EK0H to K04–K07, and EK1 to K10–K11 (K11 is not available in the E0C88308).

Interrupt is permitted in those series of terminals set to "1" and prohibited in those set to "0".

At initial reset, this register is set to "0" (interrupt prohibited).

**FK0L, FK0H, FK1: 00FF25H•D3, D4, D5**

Indicates the generation state for an input interrupt.

When "1" is read: Interrupt factor present  
 When "0" is read: Interrupt factor not present  
 When "1" is written: Reset factor flag  
 When "0" is written: Invalid

The interrupt factor flag FK0L corresponds to K00–K03, FK0H to K04–K07, and FK1 to K10–K11 (K11 is not available in the E0C88308) and they are set to "1" by the occurrence of an interrupt generation condition.

When set in this manner, if the corresponding interrupt enable register is set to "1" and the corresponding interrupt priority register is set to a higher level than the setting of interrupt flags (I0 and I1), an interrupt will be generated to the CPU. Regardless of the interrupt enable register and interrupt priority register settings, the interrupt factor flag will be set to "1" by the occurrence of an interrupt generation condition.

To accept the subsequent interrupt after interrupt generation, re-setting of the interrupt flags (set interrupt flag to lower level than the level indicated by the interrupt priority registers, or execute the RETE instruction) and interrupt factor flag reset are necessary. The interrupt factor flag is reset to "0" by writing "1".

At initial reset, this flag is all reset to "0".

**5.5.5 Programming note**

When changing the input terminal from LOW level to HIGH with the built-in pull-up resistor, a delay in the waveform rise time will occur depending on the time constant of the pull-up resistor and the load capacitance of the terminal. It is necessary to set an appropriate wait time for introduction of an input port. In particular, special attention should be paid to key scan for key matrix formation. Make this wait time the amount of time or more calculated by the following expression.

$$\text{Wait time} = R_{IN} \times (C_{IN} + \text{load capacitance on the board}) \times 1.6 \text{ [sec]}$$

R<sub>IN</sub>: Pull up resistance Max. value

C<sub>IN</sub>: Terminal capacitance Max. value

## 5.6 Output Ports (R ports)

### 5.6.1 Configuration of output ports

The E0C88348/317/316 is equipped with a 34-bit output port (R00–R07, R10–R17, R20–R27, R30–R37, R50, R51) and the E0C88308 is equipped with a 30-bit output port (R00–R07, R10–R17, R20–R27, R30–R34, R50).

Depending on the bus mode setting, the configuration of the output ports may vary as shown in the table below.

Table 5.6.1.1 Configuration of output ports

Terminal	Bus mode	
	Single chip	Expanded 64K   Expanded 512K
R00	Output port R00	Address A0
R01	Output port R01	Address A1
R02	Output port R02	Address A2
R03	Output port R03	Address A3
R04	Output port R04	Address A4
R05	Output port R05	Address A5
R06	Output port R06	Address A6
R07	Output port R07	Address A7
R10	Output port R10	Address A8
R11	Output port R11	Address A9
R12	Output port R12	Address A10
R13	Output port R13	Address A11
R14	Output port R14	Address A12
R15	Output port R15	Address A13
R16	Output port R16	Address A14
R17	Output port R17	Address A15
R20	Output port R20	Address A16
R21	Output port R21	Address A17
R22	Output port R22	Address A18
R23	Output port R23	$\overline{RD}$ signal
R24	Output port R24	$\overline{WR}$ signal
R25	Output port R25	
R26	Output port R26	
R27	Output port R27	
R30	Output port R30	Output port R30/ $\overline{CE0}$ signal
R31	Output port R31	Output port R31/ $\overline{CE1}$ signal
R32	Output port R32	Output port R32/ $\overline{CE2}$ signal
R33	Output port R33	Output port R33/ $\overline{CE3}$ signal
R34	Output port R34	
R35 *	Output port R35	
R36 *	Output port R36	
R37 *	Output port R37	
R50	Output port R50	
R51 *	Output port R51	Output port R51/ $\overline{BACK}$ signal

\* R35–R37 and R51 are not available in the E0C88308.

Only the configuration of the output ports in single chip mode will be discussed here. With respect to bus control, see "5.2 System Controller and Bus Control".

Figure 5.6.1.1 shows the basic structure (excluding special output circuits) of the output ports.

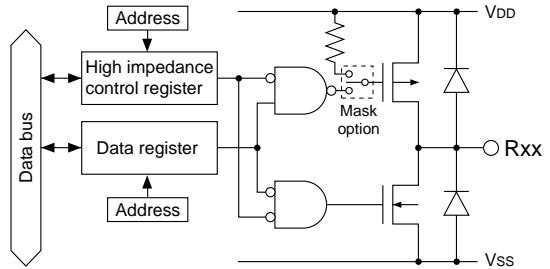

Nch open drain can be set for R00–R07 and R10–R17 by the mask option.

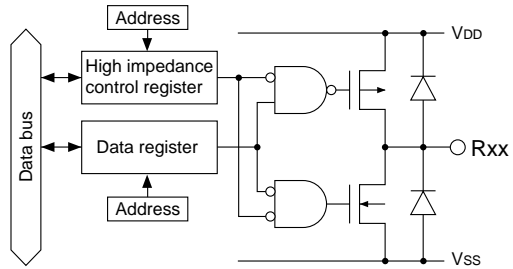

R20–R27, R30–R37, R50, R51

Fig. 5.6.1.1 Structure of output ports

In modes other than single chip mode, the data registers and high impedance control registers of the output ports used for bus function can be used as general purpose registers with read/write capabilities. This will not in any way affect bus signal output.

*Note:* When the 160-pin package is selected for a shipping form of the E0C88348/317/316, the output port terminals R35, R36 and R37 can not be used because these are non-bonding terminals. However, the data registers (R35D–R37D) and high impedance control registers (HZR35–HZR37) corresponding to these output ports can be used as general purpose registers with read/write capabilities.

The output specification of each output port is as complementary output with high impedance control in software possible.

Besides normal DC output, output ports R25–R27, R34, and R50 have a special output function, which can be selected by software.

### 5.6.2 Mask option

Output ports R00–R07 and R10–R17 output specifications

R00	.....	<input type="checkbox"/> Complementary	<input type="checkbox"/> Nch open drain
R01	.....	<input type="checkbox"/> Complementary	<input type="checkbox"/> Nch open drain
R02	.....	<input type="checkbox"/> Complementary	<input type="checkbox"/> Nch open drain
R03	.....	<input type="checkbox"/> Complementary	<input type="checkbox"/> Nch open drain
R04	.....	<input type="checkbox"/> Complementary	<input type="checkbox"/> Nch open drain
R05	.....	<input type="checkbox"/> Complementary	<input type="checkbox"/> Nch open drain
R06	.....	<input type="checkbox"/> Complementary	<input type="checkbox"/> Nch open drain
R07	.....	<input type="checkbox"/> Complementary	<input type="checkbox"/> Nch open drain
R10	.....	<input type="checkbox"/> Complementary	<input type="checkbox"/> Nch open drain
R11	.....	<input type="checkbox"/> Complementary	<input type="checkbox"/> Nch open drain
R12	.....	<input type="checkbox"/> Complementary	<input type="checkbox"/> Nch open drain
R13	.....	<input type="checkbox"/> Complementary	<input type="checkbox"/> Nch open drain
R14	.....	<input type="checkbox"/> Complementary	<input type="checkbox"/> Nch open drain
R15	.....	<input type="checkbox"/> Complementary	<input type="checkbox"/> Nch open drain
R16	.....	<input type="checkbox"/> Complementary	<input type="checkbox"/> Nch open drain
R17	.....	<input type="checkbox"/> Complementary	<input type="checkbox"/> Nch open drain

Output ports R00–R07 and R10–R17 can be used to select output specification for each port (1 bit) by mask option.

The output specification can be selected for either complementary output or Nch open drain output.

Nch open drain output is rendered suitable for purposes as key matrix common output.

For unused input ports, select the default setting of "Complementary".

*Note: When Nch open drain has been selected, voltage in excess of the supply voltage range must not applied to the output port terminal.*

### 5.6.3 High impedance control

The output port can be high impedance controlled in software.

This makes it possible to share output signal lines with an other external device.

A high impedance control register is set for each series of output port terminals as shown below. Either complementary output and high impedance state can be selected with this register.

Table 5.6.3.1 Correspondence between output ports and high impedance control registers

Register	Output port terminal
HZR0L	R00–R03
HZR0H	R04–R07
HZR1L	R10–R13
HZR1H	R14–R17
HZR20	R20
HZR21	R21
HZR22	R22
HZR23	R23
HZR24	R24
HZR25	R25
HZR26	R26
HZR27	R27
HZR30	R30
HZR31	R31
HZR32	R32
HZR33	R33
HZR34	R34
HZR35 *1	R35
HZR36 *1	R36
HZR37 *1	R37
HZR4L *2	–
HZR4H *2	–
HZR50	R50
HZR51 *1	R51

\*1 In the E0C88308, this is general purpose register with read/write capabilities.

\*2 This is a 2-bit reserved register, it can be used as a general purpose register with read/write capabilities.

When a high impedance control register HZRxx is set to "1", the corresponding output port terminal becomes high impedance state and when set to "0", it becomes complementary output.

### 5.6.4 DC output

As Figure 5.6.1.1 shows, when "1" is written to the output port data register, the output terminal switches to HIGH (VDD) level and when "0" is written it switches to LOW (Vss) level. When output is in a high impedance state, the data written to the data register is output from the terminal at the instant when output is switched to complementary.

### 5.6.5 Special output

Besides normal DC output, output ports R25–R27, R34 and R50 can also be assigned special output functions in software as shown in Table 5.6.5.1.

Table 5.6.5.1 Special output ports

Output port	Special output
R25	CL output
R26	FR output
R27	TOUT output
R34	FOUT output
R50	BZ output

#### ■ CL and FR output (R25 and R26)

In order for the E0C883xx to handle connection to an externally expanded LCD driver, output ports R25 and R26 can be used to output a CL signal (LCD synchronous signal) and FR signal (LCD frame signal), respectively. The configuration of output ports R25 and R26 are shown in Figure 5.6.5.1.

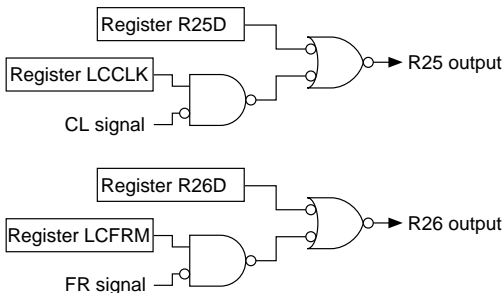

Fig. 5.6.5.1 Configuration of R25 and R26

The output control for the CL signal is done by the register LCCLK. When you set "1" for the LCCLK, the CL signal is output from the output port terminal R25, when "0" is set, the HIGH (VDD) level is output. At this time, "1" must always be set for the data register R25D.

The output control for the FR signal is done by the register LCFRM. When you set "1" for the LCFRM, the FR signal is output from the output port terminal R26, when "0" is set, the HIGH (VDD) level is output. At this time, "1" must always be set for the data register R26D.

The frequencies of each signal are changed as shown in Table 5.6.5.2 according to the drive duty selection.

Table 5.6.5.2 Frequencies of CL and FR signals

Drive duty	CL signal (Hz)	FR signal (Hz)
1/32	2,048	32
1/16	1,024	32
1/8	1,024	64

Since the signals are generated asynchronously from the registers LCCLK and LCFRM, when the signals are turned ON or OFF by the register settings, a hazard of a 1/2 cycle or less is generated. Figure 5.6.5.2 shows the output waveforms of the CL and FR signals.

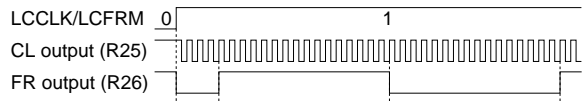

Fig. 5.6.5.2 Output waveforms of CL and FR signals

#### ■ TOUT output (R27)

In order for the E0C883xx to provide clock signal to an external device, the output port terminal R27 can be used to output a TOUT signal (clock output by the programmable timer). The configuration of output port R27 is shown in Figure 5.6.5.3.

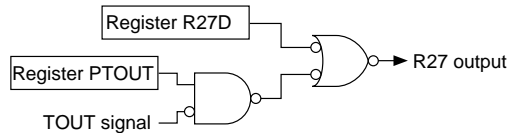

Fig. 5.6.5.3 Configuration of R27

The output control for the TOUT signal is done by the register PTOUT. When you set "1" for the PTOUT, the TOUT signal is output from the output port terminal R27, when "0" is set, the HIGH (VDD) level is output. At this time, "1" must always be set for the data register R27D.

The TOUT signal is the programmable timer underflow divided by 1/2.

With respect to frequency control, see "5.11 Programmable Timer".

Since the TOUT signal is generated asynchronously from the register PTOUT, when the signal is turned ON or OFF by the register settings, a hazard of a 1/2 cycle or less is generated.

Figure 5.6.5.4 shows the output waveform of the TOUT signal.

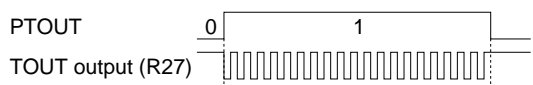

Fig. 5.6.5.4 Output waveform of TOUT signal



■ FOUT output (R34)

In order for the E0C883xx to provide clock signal to an external device, a FOUT signal (oscillation clock fosc1 or fosc3 dividing clock) can be output from the output port terminal R34.

Figure 5.6.5.5 shows the configuration of output port R34.

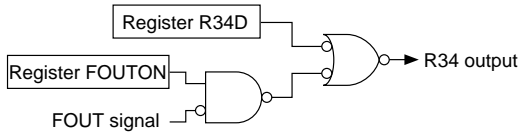

Fig. 5.6.5.5 Configuration of R34

The output control for the FOUT signal is done by the register FOUTON. When you set "1" for the FOUTON, the FOUT signal is output from the output port terminal R34, when "0" is set, the HIGH (VDD) level is output. At this time, "1" must always be set for the data register R34D.

The frequency of the FOUT signal can be selected in software by setting the registers FOUT0–FOUT2. The frequency is selected any one from among eight settings as shown in Table 5.6.5.3.

Table 5.6.5.3 FOUT frequency setting

FOUT2	FOUT1	FOUT0	FOUT frequency
0	0	0	fosc1 / 1
0	0	1	fosc1 / 2
0	1	0	fosc1 / 4
0	1	1	fosc1 / 8
1	0	0	fosc3 / 1
1	0	1	fosc3 / 2
1	1	0	fosc3 / 4
1	1	1	fosc3 / 8

fosc1: OSC1 oscillation frequency  
fosc3: OSC3 oscillation frequency

When the FOUT frequency is made "fosc3 / n", you must turn on the OSC3 oscillation circuit before outputting FOUT. A time interval of several msec to several 10 msec, from the turning ON of the OSC3 oscillation circuit to until the oscillation stabilizes, is necessary, due to the oscillation element that is used. Consequently, if an abnormality occurs as the result of an unstable FOUT signal being output externally, you should allow an adequate waiting time after turning ON of the OSC3 oscillation, before turning outputting FOUT. (The oscillation start time will vary somewhat depending on the oscillator and on the externally attached parts. Refer to the oscillation start time example indicated in Chapter 7, "ELECTRICAL CHARACTERISTICS".)

At initial reset, OSC3 oscillation circuit is set to OFF state.

Since the FOUT signal is generated asynchronously from the register FOUTON, when the signal is turned ON or OFF by the register settings, a hazard of a 1/2 cycle or less is generated.

Figure 5.6.5.6 shows the output waveform of the FOUT signal.

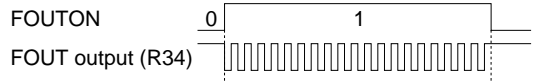

Fig. 5.6.5.6 Output waveform of FOUT signal

■ BZ output (R50)

In order for the E0C883xx to drive an external buzzer, a BZ signal (sound generator output) can be output from the output port terminal R50.

The configuration of the output port R50 is shown in Figure 5.6.5.7.

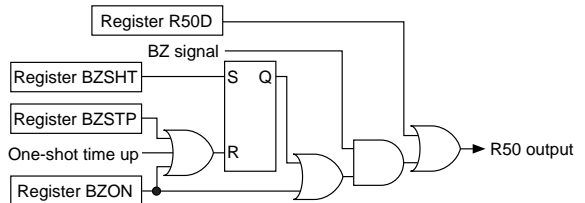

Fig. 5.6.5.7 Configuration of R50

The output control for the BZ signal is done by the registers BZON, BZSHT and BZSTP. When you set "1" for the BZON or BZSHT, the BZ signal is output from the output port terminal R50, when "0" is set for the BZON or "1" is set for the BZSTP, the LOW (Vss) level is output. At this time, "0" must always be set for the data register R50D.

The BZ signal which is output makes use of the output of the sound generator. With respect to control of frequency and envelope, see "5.13 Sound Generator".

Since the BZ signal is generated asynchronously from the registers BZON, BZSHT and BZSTP, when the signal is turned ON or OFF by the register settings, a hazard of a 1/2 cycle or less is generated. Figure 5.6.5.8 shows the output waveform of the BZ signal.

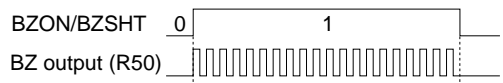

Fig. 5.6.5.8 Output waveform of BZ signal

## 5.6.6 Control of output ports

Table 5.6.6.1 shows the output port control bits.

Table 5.6.6.1(a) Output port control bits

Address	Bit	Name	Function	1	0	SR	R/W	Comment
00FF70	D7	HZR51	R51 high impedance control	High impedance	Complementary	0	R/W	*1
	D6	HZR50	R50 high impedance control					
	D5	HZR4H	R/W register	1	0	0	R/W	Reserved register
	D4	HZR4L	R/W register					
	D3	HZR1H	R14–R17 high impedance control	High impedance	Complementary	0	R/W	
	D2	HZR1L	R10–R13 high impedance control					
	D1	HZR0H	R04–R07 high impedance control					
	D0	HZR0L	R00–R03 high impedance control					
00FF71	D7	HZR27	R27 high impedance control	High impedance	Complementary	0	R/W	
	D6	HZR26	R26 high impedance control					
	D5	HZR25	R25 high impedance control					
	D4	HZR24	R24 high impedance control					
	D3	HZR23	R23 high impedance control					
	D2	HZR22	R22 high impedance control					
	D1	HZR21	R21 high impedance control					
	D0	HZR20	R20 high impedance control					
00FF72	D7	HZR37	R37 high impedance control	High impedance	Complementary	0	R/W	These are just R/W registers on E0C88308
	D6	HZR36	R36 high impedance control					
	D5	HZR35	R35 high impedance control					
	D4	HZR34	R34 high impedance control					
	D3	HZR33	R33 high impedance control					
	D2	HZR32	R32 high impedance control					
	D1	HZR31	R31 high impedance control					
	D0	HZR30	R30 high impedance control					
00FF73	D7	R07D	R07 output port data	High	Low	1	R/W	
	D6	R06D	R06 output port data					
	D5	R05D	R05 output port data					
	D4	R04D	R04 output port data					
	D3	R03D	R03 output port data					
	D2	R02D	R02 output port data					
	D1	R01D	R01 output port data					
	D0	R00D	R00 output port data					
00FF74	D7	R17D	R17 output port data	High	Low	1	R/W	
	D6	R16D	R16 output port data					
	D5	R15D	R15 output port data					
	D4	R14D	R14 output port data					
	D3	R13D	R13 output port data					
	D2	R12D	R12 output port data					
	D1	R11D	R11 output port data					
	D0	R10D	R10 output port data					
00FF75	D7	R27D	R27 output port data	High	Low	1	R/W	
	D6	R26D	R26 output port data					
	D5	R25D	R25 output port data					
	D4	R24D	R24 output port data					
	D3	R23D	R23 output port data					
	D2	R22D	R22 output port data					
	D1	R21D	R21 output port data					
	D0	R20D	R20 output port data					

\*1 This is just R/W register on E0C88308.

Table 5.6.6.1(b) Output port control bits

Address	Bit	Name	Function	1	0	SR	R/W	Comment	
00FF76	D7	R37D	R37 output port data	High	Low	1	R/W	These are just R/W registers on E0C88308	
	D6	R36D	R36 output port data						
	D5	R35D	R35 output port data						
	D4	R34D	R34 output port data						
	D3	R33D	R33 output port data						
	D2	R32D	R32 output port data						
	D1	R31D	R31 output port data						
	D0	R30D	R30 output port data						
00FF77	D7	R47D	R/W register	1	0	1	R/W	Reserved register	
	D6	R46D	R/W register						
	D5	R45D	R/W register						
	D4	R44D	R/W register						
	D3	R43D	R/W register						
	D2	R42D	R/W register						
	D1	R41D	R/W register						
	D0	R40D	R/W register						
00FF78	D7	–	–	–	–	–	–	Constantly "0" when being read	
	D6	–	–	–	–	–	–		
	D5	–	–	–	–	–	–		
	D4	–	–	–	–	–	–		
	D3	–	–	–	–	–	–		
	D2	–	–	–	–	–	–	–	
	D1	R51D	R51 output port data	High	Low	1	R/W	*1	
	D0	R50D	R50 output port data	High	Low	0	R/W		
00FF10	D7	–	–	–	–	–	–	Constantly "0" when being read	
	D6	–	–	–	–	–	–		
	D5	–	–	–	–	–	–		
	D4	LCCLK	CL output control for expanded LCD driver	On	Off	0	R/W		
	D3	LCFRM	FR output control for expanded LCD driver	On	Off	0	R/W		
	D2	DTFNT	LCD dot font selection	5 x 5 dots	5 x 8 dots	0	R/W		
	D1	LDUTY	LCD drive duty selection	1/16 duty	1/32 duty	0	R/W	*2	
	D0	SGOUT	R/W register	1	0	0	R/W	Reserved register	
00FF30	D7	–	–	–	–	–	–	Constantly "0" when being read	
	D6	–	–	–	–	–	–		
	D5	–	–	–	–	–	–		
	D4	MODE16	8/16-bit mode selection	16-bit x 1	8-bit x 2	0	R/W		
	D3	CHSEL	TOUT output channel selection	Timer 1	Timer 0	0	R/W		
	D2	PTOUT	TOUT output control	On	Off	0	R/W		
	D1	CKSEL1	Prescaler 1 source clock selection	fosc3	fosc1	0	R/W		
	D0	CKSEL0	Prescaler 0 source clock selection	fosc3	fosc1	0	R/W		
00FF44	D7	–	–	–	–	–	–	Constantly "0" when being read	
	D6	BZSTP	One-shot buzzer forcibly stop	Forcibly stop	No operation	–	W		
	D5	BZSHT	One-shot buzzer trigger/status	R	Busy	Ready	0	R/W	
				W	Trigger	No operation			
	D4	SHTPW	One-shot buzzer duration width selection	125 msec	31.25 msec	0	R/W		
	D3	ENRTM	Envelope attenuation time	1 sec	0.5 sec	0	R/W		
	D2	ENRST	Envelope reset	Reset	No operation	–	W	"0" when being read	
	D1	ENON	Envelope On/Off control	On	Off	0	R/W	*3	
D0	BZON	Buzzer output control	On	Off	0	R/W			

\*1 This is just R/W register on E0C88308.

\*2 When 1/8 duty has been selected by mask option, setting of this register becomes invalid.

\*3 Reset to "0" during one-shot output.

Table 5.6.6.1(c) Output port control bits

Address	Bit	Name	Function	1	0	SR	R/W	Comment		
00FF40	D7	–	–	–	–	–	–	"0" when being read		
	D6	FOUT2	FOUT frequency selection					0	R/W	
			FOUT2	FOUT1	FOUT0					Frequency
			0	0	0					fOSC1 / 1
			0	0	1					fOSC1 / 2
	D5	FOUT1	0	1	0	fOSC1 / 4		0	R/W	
			0	1	1	fOSC1 / 8				
			1	0	0	fOSC3 / 1				
	D4	FOUT0	1	0	1	fOSC3 / 2		0	R/W	
			1	1	0	fOSC3 / 4				
1			1	1	fOSC3 / 8					
D3	FOUTON	FOUT output control		On	Off	0	R/W			
D2	WDRST	Watchdog timer reset		Reset	No operation	–	W	Constantly "0" when		
D1	TMRST	Clock timer reset		Reset	No operation	–	W	being read		
D0	TMRUN	Clock timer Run/Stop control		Run	Stop	0	R/W			

### ■ High impedance control

**HZR0L, HZR0H: 00FF70H•D0, D1**

**HZR1L, HZR1H: 00FF70H•D2, D3**

**HZR20–HZR27: 00FF71H**

**HZR30–HZR37: 00FF72H \*1**

**HZR4L, HZR4H: 00FF70H•D4, D5 \*2**

**HZR50, HZR51: 00FF70H•D6, D7 \*1**

Sets the output terminals to a high impedance state.

When "1" is written: High impedance

When "0" is written: Complementary

Reading: Valid

HZRxx is the high impedance control register which correspond as shown in Table 5.6.3.1 to the various output port terminals.

When "1" is set to the HZRxx register, the corresponding output port terminal becomes high impedance state and when "0" is set, it becomes complementary output.

At initial reset, this register is set to "0" (complimentary).

\*1 In the E0C88308, HZR35–HZR37 and HZR51 are general purpose registers with read / write capabilities.

\*2 HZR4L and HZR4H is 2-bit reserved register, it can be used as a general purpose register with read / write capabilities.

### ■ DC output control

**R00D–R07D: 00FF73H**

**R10D–R17D: 00FF74H**

**R20D–R27D: 00FF75H**

**R30D–R37D: 00FF76H \*1**

**R40D–R47D: 00FF77H \*2**

**R50D, R51D: 00FF78H•D0, D1 \*1**

Sets the data output from the output port terminal Rxx.

When "1" is written: HIGH level output

When "0" is written: LOW level output

Reading: Valid

RxxD is the data register for each output port.

When "1" is set, the corresponding output port terminal switches to HIGH (VDD) level, and when "0" is set, it switches to LOW (Vss) level.

At initial reset, R50D is set to "0" (LOW level output), all other registers are set to "1" (HIGH level output).

The output data registers set for bus signal output can be used as general purpose registers with read / write capabilities which do not affect the output terminals.

\*1 In the E0C88308, R35D–R37D and R51D are general purpose registers with read / write capabilities.

\*2 R40D–R47D is 8-bit reserved register, it can be used as a general purpose register with read / write capabilities.

## ■ Special output control

### **LCCLK: 00FF10H•D4**

Controls the CL (LCD synchronous) signal output.

When "1" is written: CL signal output  
 When "0" is written: HIGH level (DC) output  
 Reading: Valid

LCCLK is the output control register for CL signal. When "1" is set, the CL signal is output from the output port terminal R25 and when "0" is set, HIGH (VDD) level is output. At this time, "1" must always be set for the data register R25D. At initial reset, LCCLK is set to "0" (HIGH level output).

### **LCFRM: 00FF10H•D3**

Controls the FR (LCD frame) signal output.

When "1" is written: FR signal output  
 When "0" is written: HIGH level (DC) output  
 Reading: Valid

LCFRM is the output control register for FR signal. When "1" is set, the FR signal is output from the output port terminal R26 and when "0" is set, HIGH (VDD) level is output. At this time, "1" must always be set for the data register R26D. At initial reset, LCFRM is set to "0" (HIGH level output).

### **PTOUT: 00FF30H•D2**

Controls the TOUT (programmable timer output clock) signal output.

When "1" is written: TOUT signal output  
 When "0" is written: HIGH level (DC) output  
 Reading: Valid

PTOUT is the output control register for TOUT signal. When "1" is set, the TOUT signal is output from the output port terminal R27 and when "0" is set, HIGH (VDD) level is output. At this time, "1" must always be set for the data register R27D. At initial reset, PTOUT is set to "0" (HIGH level output).

### **FOUTON: 00FF40H•D3**

Controls the FOUT (fosc1 / fosc3 dividing clock) signal output.

When "1" is written: FOUT signal output  
 When "0" is written: HIGH level (DC) output  
 Reading: Valid

FOUTON is the output control register for FOUT signal. When "1" is set, the FOUT signal is output from the output port terminal R34 and when "0" is set, HIGH (VDD) level is output. At this time, "1" must always be set for the data register R34D. At initial reset, FOUTON is set to "0" (HIGH level output).

### **FOUT0, FOUT1, FOUT2: 00FF40H•D4, D5, D6**

FOUT signal frequency is set as shown in Table 5.6.6.2.

Table 5.6.6.2 FOUT frequency settings

FOUT2	FOUT1	FOUT0	FOUT frequency
0	0	0	fosc1 / 1
0	0	1	fosc1 / 2
0	1	0	fosc1 / 4
0	1	1	fosc1 / 8
1	0	0	fosc3 / 1
1	0	1	fosc3 / 2
1	1	0	fosc3 / 4
1	1	1	fosc3 / 8

fosc1: OSC1 oscillation frequency  
 fosc3: OSC3 oscillation frequency

At initial reset, this register is set to "0" (fosc1 / 1).

### **BZON: 00FF44H•D0**

Controls the BZ (buzzer) signal output.

When "1" is written: BZ signal output  
 When "0" is written: LOW level (DC) output  
 Reading: Valid

BZON is the output control register for BZ signal. When "1" is set, the BZ signal is output from the output port terminal R50 and when "0" is set, LOW (Vss) level is output. At this time, "0" must always be set for the data register R50D. At initial reset, BZON is set to "0" (LOW level output).

**BZSHT: 00FF45H•D5**

Controls the one-shot buzzer output.

- When "1" is written: Trigger
- When "0" is written: No operation
- When "1" is read: Busy
- When "0" is read: Ready

Writing "1" into BZSHT causes the one-shot output circuit to operate and the BZ signal to be output. The buzzer output is automatically turned OFF after the time set by SHTPW has elapsed. At this time, "0" must always be set for the data register R50D.

The one-shot output is only valid when the normal buzzer output is OFF (BZON = "0") state. The trigger is invalid during ON (BZON = "1") state. When a re-trigger is assigned during a one-shot output, the one-shot output time set with SHTPW is measured again from that point. (time extension) The operation status of the one-shot output circuit can be confirmed by reading BZSHT, when the one-shot output is ON, BZSHT reads "1" and when the output is OFF, it reads "0".

At initial reset, BZSHT is set to "0" (ready).

**BZSTP: 00FF45H•D6**

Forcibly stops the one-shot buzzer output.

- When "1" is written: Forcibly stop
- When "0" is written: No operation
- Reading: Constantly "0"

By writing "1" into BZSTP, the one-shot buzzer output can be stopped prior to the elapsing of the time set with SHTPW.

Writing "0" is invalid and writing "1" except during one-shot output is also invalid.

When "1" is written to BZSHT and BZSTP simultaneously, BZSTP takes precedence and one-shot output becomes stop status.

Since BZSTP is for writing only, during readout it is constantly set to "0".

**5.6.7 Programming notes**

- (1) Since the special output signals (CL, FR, TOUT, FOUT and BZ) are generated asynchronously from the output control registers (LCCLK, LCFRM, PTOUT, FOUTON, BZON, BZSHT and BZSTP), when the signals is turned ON or OFF by the output control register settings, a hazard of a 1/2 cycle or less is generated.
- (2) When the FOUT frequency is made "f<sub>OSC3</sub>/n", you must turn on the OSC3 oscillation circuit before outputting FOUT. A time interval of several msec to several 10 msec, from the turning ON of the OSC3 oscillation circuit to until the oscillation stabilizes, is necessary, due to the oscillation element that is used. Consequently, if an abnormality occurs as the result of an unstable FOUT signal being output externally, you should allow an adequate waiting time after turning ON of the OSC3 oscillation, before turning outputting FOUT. (The oscillation start time will vary somewhat depending on the oscillator and on the externally attached parts. Refer to the oscillation start time example indicated in Chapter 7, "ELECTRICAL CHARACTERISTICS".)  
At initial reset, OSC3 oscillation circuit is set to OFF state.
- (3) The SLP instruction has executed when the special output signals (TOUT, FOUT and BZ) are in the enable status, an unstable clock is output for the special output at the time of return from the SLEEP state. Consequently, when shifting to the SLEEP state, you should set the special output signal to the disable status prior to executing the SLP instruction.

## 5.7 I/O Ports (P ports)

### 5.7.1 Configuration of I/O ports

The E0C883xx is equipped with 16 bits of I/O ports (P00–P07, P10–P17). The configuration of these I/O ports will vary according to the bus mode as shown below.

Table 5.7.1.1 Configuration of I/O ports

Terminal	Bus mode		
	Single chip	Expanded 64K	Expanded 512K
P00	I/O port P00	Data bus D0	
P01	I/O port P01	Data bus D1	
P02	I/O port P02	Data bus D2	
P03	I/O port P03	Data bus D3	
P04	I/O port P04	Data bus D4	
P05	I/O port P05	Data bus D5	
P06	I/O port P06	Data bus D6	
P07	I/O port P07	Data bus D7	
P10	I/O port P10 (SIN)		
P11	I/O port P11 (SOUT)		
P12	I/O port P12 (SCLK)		
P13	I/O port P13 (SRDY)		
P14	I/O port P14 (CMPP0)		
P15	I/O port P15 (CMPM0)		
P16	I/O port P16 (CMPP1)		
P17	I/O port P17 (CMPM1)		

With respect to the data bus, see "5.2 System Controller and Bus Control".

Figure 5.7.1.1 shows the structure of an I/O port.

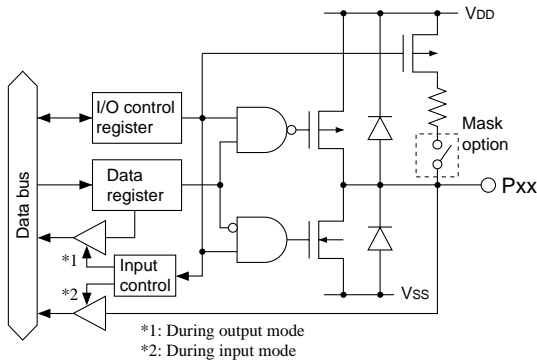

Fig. 5.7.1.1 Structure of I/O port

I/O port can be set for input or output mode in one bit unit. These settings are performed by writing data to the I/O control registers.

I/O port terminals P10–P13 and P14–P17 are shared with serial interface input/output terminal and analog comparator input terminals, respectively. The function of each terminals is switchable in software. With respect to serial interface and analog comparator, see "5.8 Serial Interface" and "5.14 Analog Comparator", respectively.

The data registers and I/O control registers of I/O ports set for data bus and serial interface output terminals use are usable as general purpose registers with read/write capabilities which do not affect I/O activities of the terminal.

The same as above, the I/O control register of I/O port set for serial interface input terminal use is usable as general purpose register.

### 5.7.2 Mask option

#### I/O port pull-up resistors

P00	..... <input type="checkbox"/> With resistor	<input type="checkbox"/> Gate direct
P01	..... <input type="checkbox"/> With resistor	<input type="checkbox"/> Gate direct
P02	..... <input type="checkbox"/> With resistor	<input type="checkbox"/> Gate direct
P03	..... <input type="checkbox"/> With resistor	<input type="checkbox"/> Gate direct
P04	..... <input type="checkbox"/> With resistor	<input type="checkbox"/> Gate direct
P05	..... <input type="checkbox"/> With resistor	<input type="checkbox"/> Gate direct
P06	..... <input type="checkbox"/> With resistor	<input type="checkbox"/> Gate direct
P07	..... <input type="checkbox"/> With resistor	<input type="checkbox"/> Gate direct
P10	..... <input type="checkbox"/> With resistor	<input type="checkbox"/> Gate direct
P11	..... <input type="checkbox"/> With resistor	<input type="checkbox"/> Gate direct
P12	..... <input type="checkbox"/> With resistor	<input type="checkbox"/> Gate direct
P13	..... <input type="checkbox"/> With resistor	<input type="checkbox"/> Gate direct
P14	..... <input type="checkbox"/> With resistor	<input type="checkbox"/> Gate direct
P15	..... <input type="checkbox"/> With resistor	<input type="checkbox"/> Gate direct
P16	..... <input type="checkbox"/> With resistor	<input type="checkbox"/> Gate direct
P17	..... <input type="checkbox"/> With resistor	<input type="checkbox"/> Gate direct

I/O ports P00–P07 and P10–P17 are equipped with a pull-up resistor which goes ON in the input mode. Whether this resistor is used or not can be selected for each port (one bit unit).

In cases where the 'With resistor' option is selected, the pull-up resistor goes ON when the port is in input mode.

When changing the port terminal from LOW level to HIGH with the built-in pull-up resistor, a delay in the waveform rise time will occur depending on the time constant of the pull-up resistor and the load capacitance of the terminal. It is necessary to set an appropriate wait time for introduction of an I/O port. Make this wait time the amount of time or more calculated by the following expression.

$$\text{Wait time} = R_{IN} \times (C_{IN} + \text{load capacitance on the board}) \times 1.6 \text{ [sec]}$$

$R_{IN}$ : Pull up resistance Max. value

$C_{IN}$ : Terminal capacitance Max. value

When the analog comparator is used, select "Gate direct" for I/O ports (P14–P15 or P16–P17, or both) which then become input terminals.

For unused I/O ports, select the default setting of "With resistor".

**5.7.3 I/O control registers and I/O mode**

I/O ports P00–P07 and P10–P17 are set either to input or output modes by writing data to the I/O control registers IOC00–IOC07 and IOC10–IOC17 which correspond to each bit.

To set an I/O port to input mode, write "0" to the I/O control register.

An I/O port which is set to input mode will shift to a high impedance state and functions as an input port. Readout in input mode consists simply of a direct readout of the input terminal state: the data being "1" when the input terminal is at HIGH (VDD) level and "0" when it is at LOW (VSS) level.

When the "With resistor" option is selected using the mask option, the resistor is pulled up onto the port terminal in input mode.

Even in input mode, data can be written to the data registers without affecting the terminal state.

To set an I/O port to output mode, write "1" to the I/O control register. An I/O port which is set to output mode functions as an output port.

When port output data is "1", a HIGH (VDD) level is output and when it is "0", a LOW (VSS) level is output. Readout in output mode consists of the contents of the data register.

At initial reset, I/O control registers are set to "0" (I/O ports are set to input mode).

**5.7.4 Control of I/O ports**

Table 5.7.4.1 shows the I/O port control bits.

Table 5.7.4.1 I/O port control bits

Address	Bit	Name	Function	1	0	SR	R/W	Comment
00FF60	D7	IOC07	P07 I/O control register	Output	Input	0	R/W	
	D6	IOC06	P06 I/O control register					
	D5	IOC05	P05 I/O control register					
	D4	IOC04	P04 I/O control register					
	D3	IOC03	P03 I/O control register					
	D2	IOC02	P02 I/O control register					
	D1	IOC01	P01 I/O control register					
	D0	IOC00	P00 I/O control register					
00FF61	D7	IOC17	P17 I/O control register	Output	Input	0	R/W	
	D6	IOC16	P16 I/O control register					
	D5	IOC15	P15 I/O control register					
	D4	IOC14	P14 I/O control register					
	D3	IOC13	P13 I/O control register					
	D2	IOC12	P12 I/O control register					
	D1	IOC11	P11 I/O control register					
	D0	IOC10	P10 I/O control register					
00FF62	D7	P07D	P07 I/O port data	High	Low	1	R/W	
	D6	P06D	P06 I/O port data					
	D5	P05D	P05 I/O port data					
	D4	P04D	P04 I/O port data					
	D3	P03D	P03 I/O port data					
	D2	P02D	P02 I/O port data					
	D1	P01D	P01 I/O port data					
	D0	P00D	P00 I/O port data					
00FF63	D7	P17D	P17 I/O port data	High	Low	1	R/W	
	D6	P16D	P16 I/O port data					
	D5	P15D	P15 I/O port data					
	D4	P14D	P14 I/O port data					
	D3	P13D	P13 I/O port data					
	D2	P12D	P12 I/O port data					
	D1	P11D	P11 I/O port data					
	D0	P10D	P10 I/O port data					



**P00D–P07D, P10D–P17D: 00FF62H, 00FF63H**

How I/O port terminal Pxx data readout and output data settings are performed.

**When writing data:**

When "1" is written: HIGH level  
When "0" is written: LOW level

When the I/O port is set to output mode, the data written is output as is to the I/O port terminal. In terms of port data, when "1" is written, the port terminal goes to HIGH (VDD) level and when "0" is written to a LOW (Vss) level.

Even when the port is in input mode, data can still be written in.

**When reading out data:**

When "1" is read: HIGH level ("1")  
When "0" is read: LOW level ("0")

When an I/O port is in input mode, the voltage level being input to the port terminal is read out. When terminal voltage is HIGH (VDD), it is read as a "1", and when it is LOW (Vss), it is read as a "0". Furthermore, in output mode, the contents of the data register are read out.

At initial reset, this register is set to "1" (HIGH level).

*Note: The data registers of I/O ports set for the data bus and output terminal of serial interface can be used as general purpose registers with read/write capabilities which do not affect I/O activities of the terminals.*

**IOC00–IOC07: 00FF60H****IOC10–IOC17: 00FF61H**

Sets the I/O ports to input or output mode.

When "1" is written: Output mode  
When "0" is written: Input mode  
Reading: Valid

IOCxx is the I/O control register which correspond to each I/O port in a bit unit.

Writing "1" to the IOCxx register will switch the corresponding I/O port Pxx to output mode, and writing "0" will switch it to input mode.

When the analog comparator is used, "0" must always be set for the I/O control registers (IOC14–IOC15 or IOC16–IOC17, or both) of I/O ports which will become input terminals.

At initial reset, this register is set to "0" (input mode).

*Note: The data registers of I/O ports set for the data bus and input terminal of serial interface can be used as general purpose registers with read/write capabilities which do not affect I/O activities of the terminals.*

**5.7.5 Programming notes**

- (1) When changing the port terminal from LOW level to HIGH with the built-in pull-up resistor, a delay in the waveform rise time will occur depending on the time constant of the pull-up resistor and the load capacitance of the terminal. It is necessary to set an appropriate wait time for introduction of an I/O port. Make this wait time the amount of time or more calculated by the following expression.

**Wait time =  $R_{IN} \times (C_{IN} + \text{load capacitance on the board}) \times 1.6$  [sec]**

$R_{IN}$ : Pull up resistance Max. value

$C_{IN}$ : Terminal capacitance Max. value

- (2) When the analog comparator is used, "0" must always be set for the I/O control registers (IOC14–IOC15 or IOC16–IOC17, or both) of I/O ports which will become input terminals.

## 5.8 Serial Interface

### 5.8.1 Configuration of serial interface

The E0C883xx incorporates a full duplex serial interface (when asynchronous system is selected) that allows the user to select either clock synchronous system or asynchronous system.

The data transfer method can be selected in software.

When the clock synchronous system is selected, 8-bit data transfer is possible.

When the asynchronous system is selected, either 7-bit or 8-bit data transfer is possible, and a parity check of received data and the addition of a parity bit for transmitting data can automatically be done by selecting in software.

Figure 5.8.1.1 shows the configuration of the serial interface.

Serial interface input/output terminals, SIN, SOUT,  $\overline{\text{SCLK}}$  and  $\overline{\text{SRDY}}$  are shared with I/O ports P10–P13. In order to utilize these terminals for the serial interface input/output terminals, proper settings have to be made with registers ESIF, SMD0 and SMD1. (At initial reset, these terminals are set as I/O port terminals.)

The direction of I/O port terminals set for serial interface input/output terminals are determined by the signal and transfer mode for each terminal. Furthermore, the settings for the corresponding I/O control registers for the I/O ports become invalid.

Table 5.8.1.1 Configuration of input/output terminals

Terminal	When serial interface is selected
P10	SIN
P11	SOUT
P12	$\overline{\text{SCLK}}$
P13	$\overline{\text{SRDY}}$

\* The terminals used may vary depending on the transfer mode.

SIN and SOUT are serial data input and output terminals which function identically in clock synchronous system and asynchronous system.  $\overline{\text{SCLK}}$  is exclusively for use with clock synchronous system and functions as a synchronous clock input/output terminal.  $\overline{\text{SRDY}}$  is exclusively for use in clock synchronous slave mode and functions as a send-receive ready signal output terminal.

When asynchronous system is selected, since  $\overline{\text{SCLK}}$  and  $\overline{\text{SRDY}}$  are superfluous, the I/O port terminals P12 and P13 can be used as I/O ports.

In the same way, when clock synchronous master mode is selected, since  $\overline{\text{SRDY}}$  is superfluous, the I/O port terminal P13 can be used as I/O port.

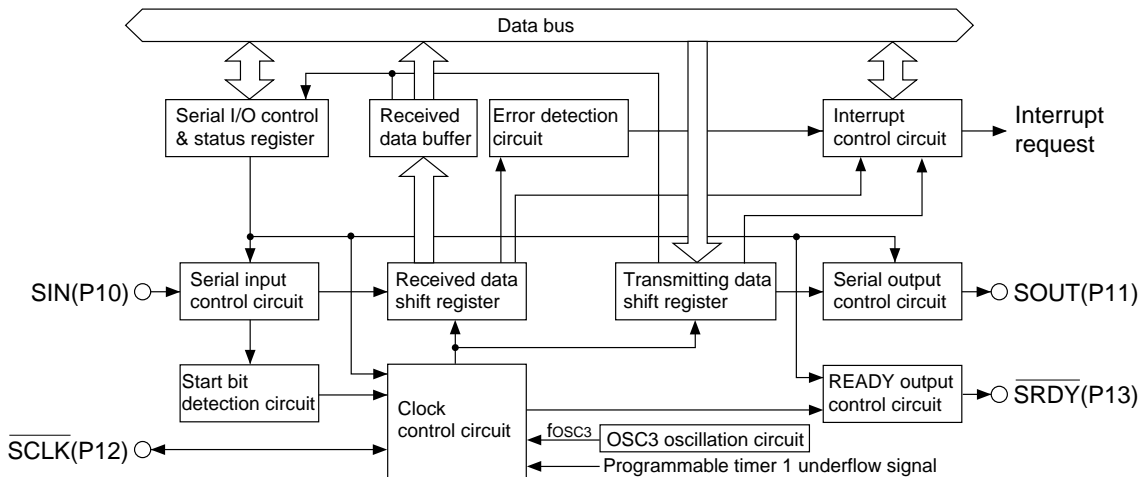

Fig. 5.8.1.1 Configuration of serial interface

### 5.8.2 Mask option

Since serial interface input/output terminals are shared with the I/O ports, serial interface terminal specifications have necessarily been selected with the mask option for I/O ports.

I/O port pull-up resistors  
 P10 (SIN) .....  With resistor  Gate direct  
 P12 ( $\overline{\text{SCLK}}$ ) ....  With resistor  Gate direct

Each I/O port terminal is equipped with a pull-up resistor which goes ON in input mode. A selection can be made for each port (one bit unit) as to whether or not the resistor will be used. Specifications (whether the pull-up will be used or not) of P10 (SIN) and P12 ( $\overline{\text{SCLK}}$ ) which will become input terminals when using the serial interface are decided by settings for the I/O port.

When "Gate direct" is selected in the serial I/F mode, be sure that the input terminals do not go into a floating state.

### 5.8.3 Transfer modes

There are four transfer modes for the serial interface and mode selection is made by setting the two bits of the mode selection registers SMD0 and SMD1 as shown in the table below.

Table 5.8.3.1 Transfer modes

SMD1	SMD0	Mode
1	1	Asynchronous 8-bit
1	0	Asynchronous 7-bit
0	1	Clock synchronous slave
0	0	Clock synchronous master

Table 5.8.3.2 Terminal settings corresponding to each transfer mode

Mode	SIN	SOUT	$\overline{\text{SCLK}}$	$\overline{\text{SRDY}}$
Asynchronous 8-bit	Input	Output	P12	P13
Asynchronous 7-bit	Input	Output	P12	P13
Clock synchronous slave	Input	Output	Input	Output
Clock synchronous master	Input	Output	Output	P13

At initial reset, transfer mode is set to clock synchronous master mode.

#### ■ Clock synchronous master mode

In this mode, the internal clock is utilized as a synchronous clock for the built-in shift registers, and clock synchronous 8-bit serial transfers can be performed with this serial interface as the master.

The synchronous clock is also output from the  $\overline{\text{SCLK}}$  terminal which enables control of the external (slave side) serial I/O device. Since the  $\overline{\text{SRDY}}$  terminal is not utilized in this mode, it can be used as an I/O port.

Figure 5.8.3.1(a) shows the connection example of input/output terminals in the clock synchronous master mode.

#### ■ Clock synchronous slave mode

In this mode, a synchronous clock from the external (master side) serial input/output device is utilized and clock synchronous 8-bit serial transfers can be performed with this serial interface as the slave. The synchronous clock is input to the  $\overline{\text{SCLK}}$  terminal and is utilized by this interface as the synchronous clock.

Furthermore, the  $\overline{\text{SRDY}}$  signal indicating the transmit-receive ready status is output from the  $\overline{\text{SRDY}}$  terminal in accordance with the serial interface operating status.

In the slave mode, the settings for registers SCS0 and SCS1 used to select the clock source are invalid. Figure 5.8.3.1(b) shows the connection example of input/output terminals in the clock synchronous slave mode.

#### ■ Asynchronous 7-bit mode

In this mode, asynchronous 7-bit transfer can be performed. Parity check during data reception and addition of parity bit (odd/even/none) during transmitting can be specified and data processed in 7 bits with or without parity. Since this mode employs the internal clock, the  $\overline{\text{SCLK}}$  terminal is not used. Furthermore, since the  $\overline{\text{SRDY}}$  terminal is not utilized either, both of these terminals can be used as I/O ports.

Figure 5.8.3.1(c) shows the connection example of input/output terminals in the asynchronous mode.

#### ■ Asynchronous 8-bit mode

In this mode, asynchronous 8-bit transfer can be performed. Parity check during data reception and addition of parity bit (odd/even/none) during transmitting can be specified and data processed in 8 bits with or without parity. Since this mode employs the internal clock, the  $\overline{\text{SCLK}}$  terminal is not used. Furthermore, since the  $\overline{\text{SRDY}}$  terminal is not utilized either, both of these terminals can be used as I/O ports.

Figure 5.8.3.1(c) shows the connection example of input/output terminals in the asynchronous mode.

5 PERIPHERAL CIRCUITS AND THEIR OPERATION (Serial Interface)

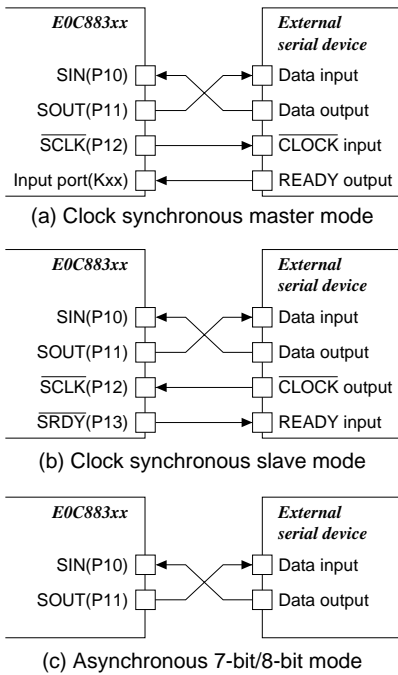

Fig. 5.8.3.1 Connection examples of serial interface I/O terminals

5.8.4 Clock source

There are four clock sources and selection is made by setting the two bits of the clock source selection register SCS0 and SCS1 as shown in table below.

Table 5.8.4.1 Clock source

SCS1	SCS0	Clock source
1	1	Programmable timer
1	0	fosc3 / 4
0	1	fosc3 / 8
0	0	fosc3 / 16

This register setting is invalid in clock synchronous slave mode and the external clock input from the SCLK terminal is used.

When the "programmable timer" is selected, the programmable timer 1 underflow signal is divided by 1/2 and this signal used as the clock source. With respect to the transfer rate setting, see "5.11 Programmable Timer".

At initial reset, the synchronous clock is set to "fosc3/16".

Whichever clock is selected, the signal is further divided by 1/16 and then used as the synchronous clock.

Furthermore, external clock input is used as is for SCLK in clock synchronous slave mode.

Table 5.8.4.2 shows an examples of transfer rates and OSC3 oscillation frequencies when the clock source is set to programmable timer.

When the demultiplied signal of the OSC3 oscillation circuit is made the clock source, it is necessary to turn the OSC3 oscillation ON, prior to using the serial interface.

A time interval of several msec to several 10 msec, from the turning ON of the OSC3 oscillation circuit until the oscillation stabilizes, is necessary, due to the oscillation element that is used. Consequently, you should allow an adequate waiting time after turning ON of the OSC3 oscillation, before starting transmitting/receiving of serial interface. (The oscillation start time will vary somewhat depending on the oscillator and on the externally attached parts. Refer to the oscillation start time example indicated in Chapter 7, "ELECTRICAL CHARACTERISTICS".) At initial reset, the OSC3 oscillation circuit is set to OFF status.

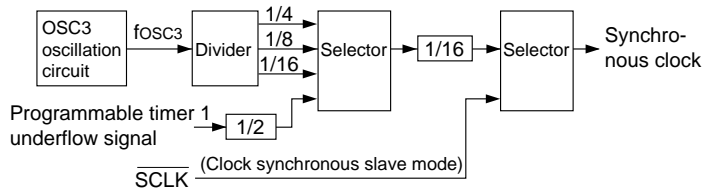

Fig. 5.8.4.1 Division of the synchronous clock

Table 5.8.4.2 OSC3 oscillation frequencies and transfer rates

Transfer rate (bps)	OSC3 oscillation frequency / Programmable timer settings					
	fosc3 = 3.072 MHz		fosc3 = 4.608 MHz		fosc3 = 4.9152 MHz	
	PSC1X	RLD1X	PSC1X	RLD1X	PSC1X	RLD1X
9,600	0 (1/1)	09H	0 (1/1)	0EH	0 (1/1)	0FH
4,800	0 (1/1)	13H	0 (1/1)	1DH	0 (1/1)	1FH
2,400	0 (1/1)	27H	0 (1/1)	3BH	0 (1/1)	3FH
1,200	0 (1/1)	4FH	0 (1/1)	77H	0 (1/1)	7FH
600	0 (1/1)	9FH	0 (1/1)	EFH	0 (1/1)	FFH
300	1 (1/4)	4FH	1 (1/4)	77H	1 (1/4)	7FH
150	1 (1/4)	9FH	1 (1/4)	EFH	1 (1/4)	FFH

### 5.8.5 Transmit-receive control

Below is a description of the registers which handle transmit-receive control. With respect to transmit-receive control procedures and operations, please refer to the following sections in which these are discussed on a mode by mode basis.

#### ■ Shift register and received data buffer

Exclusive shift registers for transmitting and receiving are installed in this serial interface. Consequently, duplex communication simultaneous transmit and receive is possible when the asynchronous system is selected.

Data being transmitted are written to TRXD0–TRXD7 and converted to serial through the shift register and is output from the SOUT terminal.

In the reception section, a received data buffer is installed separate from the shift register. Data being received are input to the SIN terminal and is converted to parallel through the shift register and written to the received data buffer. Since the received data buffer can be read even during serial input operation, the continuous data is received efficiently. However, since buffer functions are not used in clock synchronous mode, be sure to read out data before the next data reception begins.

#### ■ Transmit enable register and transmit control bit

For transmitting control, use the transmit enable register TXEN and transmit control bit TXTRG.

The transmit enable register TXEN is used to set the transmitting enable/disable status. When "1" is written to this register to set the transmitting enable status, clock input to the shift register is enabled and the system is ready to transmit data. In the clock synchronous mode, synchronous clock input/output from the  $\overline{\text{SCLK}}$  terminal is also enabled.

The transmit control bit TXTRG is used as the trigger to start transmitting data. Data to be transmitted is written to the transmit data shift register, and when transmitting preparations are complete, "1" is written to TXTRG whereupon data transmitting begins. When interrupt has been enabled, an interrupt is generated when the transmission is completed. If there is subsequent data to be transmitted it can be sent using this interrupt.

In addition, TXTRG can be read as the status. When set to "1", it indicates transmitting operation, and "0" indicates transmitting stop.

For details on timing, see the timing chart which gives the timing for each mode.

When not transmitting, set TXEN to "0" to disable transmitting status.

#### ■ Receive enable register, receive control bit

For receiving control, use the receive enable register RXEN and receive control bit RXTRG.

Receive enable register RXEN is used to set receiving enable/disable status. When "1" is written into this register to set the receiving enable status, clock input to the shift register is enabled and the system is ready to receive data. In the clock synchronous mode, synchronous clock input/output from the SCLK terminal is also enabled.

With the above setting, receiving begins and serial data input from the SIN terminal goes to the shift register.

The operation of the receive control bit RXTRG is slightly different depending on whether a clock synchronous system or an asynchronous system is being used.

In the clock synchronous system, the receive control bit TXTRG is used as the trigger to start receiving data.

When received data has been read and the preparation for next data receiving is completed, write "1" into RXTRG to start receiving. (When "1" is written to RXTRG in slave mode,  $\overline{\text{SRDY}}$  switches to "0".)

In an asynchronous system, RXTRG is used to prepare for next data receiving. After reading the received data from the received data buffer, write "1" into RXTRG to signify that the received data buffer is empty. If "1" is not written into RXTRG, the overrun error flag OER will be set to "1" when the next receiving operation is completed. (An overrun error will be generated when receiving is completed between reading the received data and the writing of "1" to RXTRG.)

In addition, RXTRG can be read as the status. In either clock synchronous mode or asynchronous mode, when RXTRG is set to "1", it indicates receiving operation and when set to "0", it indicates that receiving has stopped.

For details on timing, see the timing chart which gives the timing for each mode.

When you do not receive, set RXEN to "0" to disable receiving status.

### 5.8.6 Operation of clock synchronous transfer

Clock synchronous transfer involves the transfer of 8-bit data by synchronizing it to eight clocks. The same synchronous clock is used by both the transmitting and receiving sides.

When the serial interface is used in the master mode, the clock signal selected using SCS0 and SCS1 is further divided by 1/16 and employed as the synchronous clock. This signal is then sent via the SCLK terminal to the slave side (external serial I/O device).

When used in the slave mode, the clock input to the SCLK terminal from the master side (external serial input/output device) is used as the synchronous clock.

In the clock synchronous mode, since one clock line (SCLK) is shared for both transmitting and receiving, transmitting and receiving cannot be performed simultaneously. (Half duplex only is possible in clock synchronous mode.)

Transfer data is fixed at 8 bits and both transmitting and receiving are conducted with the LSB (bit 0) coming first.

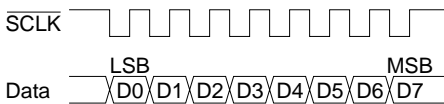

Fig. 5.8.6.1 Transfer data configuration using clock synchronous mode

Below is a description of initialization when performing clock synchronous transfer, transmit-receive control procedures and operations. With respect to serial interface interrupt, see "5.8.8 Interrupt function".

■ Initialization of serial interface

When performing clock synchronous transfer, the following initial settings must be made.

- (1) Setting of transmitting/receiving disable  
To set the serial interface into a status in which both transmitting and receiving are disabled, "0" must be written to both the transmit enable register TXEN and the receive enable register RXEN. Fix these two registers to a disable status until data transfer actually begins.

- (2) Port selection  
Because serial interface input/output ports SIN, SOUT, SCLK and SRDY are set as I/O port terminals P10–P13 at initial reset, "1" must be written to the serial interface enable register ESIF in order to set these terminals for serial interface use.

- (3) Setting of transfer mode  
Select the clock synchronous mode by writing the data as indicated below to the two bits of the mode selection registers SMD0 and SMD1.

**Master mode:** SMD0 = "0", SMD1 = "0"  
**Slave mode:** SMD0 = "1", SMD1 = "0"

- (4) Clock source selection  
In the master mode, select the synchronous clock source by writing data to the two bits of the clock source selection registers SCS0 and SCS1. (See Table 5.8.4.1.)  
This selection is not necessary in the slave mode.

Since all the registers mentioned in (2)–(4) are assigned to the same address, it's possible to set them all with one instruction. The parity enable register EPR is also assigned to this address, however, since parity is not necessary in the clock synchronous mode, parity check will not take place regardless of how they are set.

- (5) Clock source control  
When the master mode is selected and programmable timer for the clock source is selected, set transfer rate on the programmable timer side. (See "5.11 Programmable Timer".)  
When the divided signal of OSC3 oscillation circuit is selected for the clock source, be sure that the OSC3 oscillation circuit is turned ON prior to commencing data transfer. (See "5.4 Oscillation Circuit and Operating Mode".)

### ■ Data transmit procedure

The control procedure and operation during transmitting is as follows.

- (1) Write "0" in the transmit enable register TXEN and the receive enable register RXEN to reset the serial interface.
- (2) Write "1" in the transmit enable register TXEN to set into the transmitting enable status.
- (3) Write the transmitting data into TRXD0–TRXD7.
- (4) In case of the master mode, confirm the receive ready status on the slave side (external serial input/output device), if necessary. Wait until it reaches the receive ready status.
- (5) Write "1" in the transmit control bit TXTRG and start transmitting.

In the master mode, this control causes the synchronous clock to change to enable and to be provided to the shift register for transmitting and output from the SCLK terminal.

In the slave mode, it waits for the synchronous clock to be input from the  $\overline{\text{SCLK}}$  terminal. The transmitting data of the shift register shifts one bit at a time at each falling edge of the synchronous clock and is output from the SOUT terminal. When the final bit (MSB) is output, the SOUT terminal is maintained at that level, until the next transmitting begins.

The transmitting complete interrupt factor flag FSTRA is set to "1" at the point where the data transmitting of the shift register is completed. When interrupt has been enabled, a transmitting complete interrupt is generated at this point.

Set the following transmitting data using this interrupt.

- (6) Repeat steps (3) to (5) for the number of bytes of transmitting data, and then set the transmit disable status by writing "0" to the transmit enable register TXEN, when the transmitting is completed.

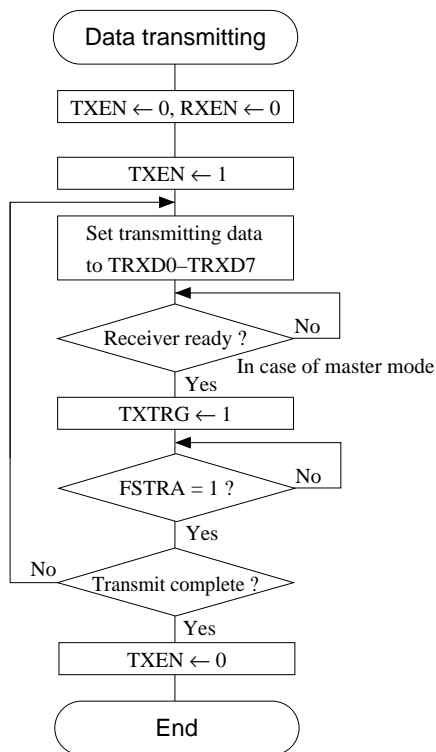

Fig. 5.8.6.2 Transmit procedure in clock synchronous mode

■ Data receive procedure

The control procedure and operation during receiving is as follows.

- (1) Write "0" in the receive enable register RXEN and transmit enable register TXEN to reset the serial interface.
- (2) Write "1" in the receive enable register RXEN to set into the receiving enable status.
- (3) In case of the master mode, confirm the transmit ready status on the slave side (external serial input/output device), if necessary. Wait until it reaches the transmit ready status.
- (4) Write "1" in the receive control bit RXTRG and start receiving.

In the master mode, this control causes the synchronous clock to change to enable and is provided to the shift register for receiving and output from the  $\overline{SCLK}$  terminal.

In the slave mode, it waits for the synchronous clock to be input from the  $\overline{SCLK}$  terminal. The received data input from the SIN terminal is successively incorporated into the shift register in synchronization with the rising edge of the synchronous clock.

At the point where the data of the 8th bit has been incorporated at the final (8th) rising edge of the synchronous clock, the content of the shift register is sent to the received data buffer and the receiving complete interrupt factor flag FSREC is set to "1". When interrupt has been enabled, a receiving complete interrupt is generated at this point.

- (5) Read the received data from TRXD0-TRXD7 using receiving complete interrupt.
- (6) Repeat steps (3) to (5) for the number of bytes of receiving data, and then set the receive disable status by writing "0" to the receive enable register RXEN, when the receiving is completed.

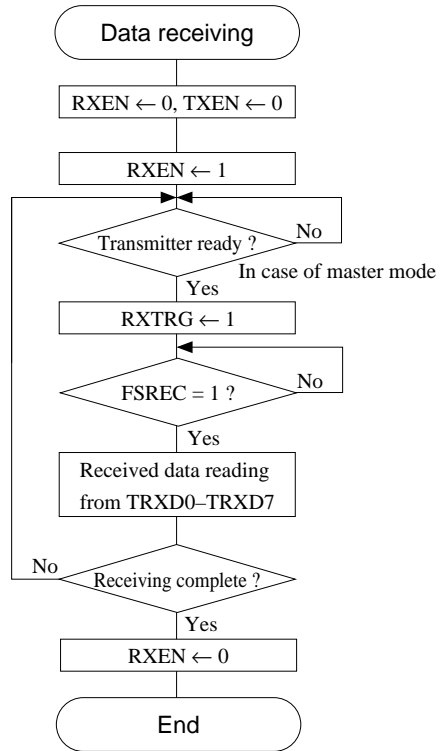

Fig. 5.8.6.3 Receiving procedure in clock synchronous mode



■ **Transmit/receive ready (SRDY) signal**

When this serial interface is used in the clock synchronous slave mode (external clock input), an SRDY signal is output to indicate whether or not this serial interface can transmit/receive to the master side (external serial input/output device). This signal is output from the SRDY terminal and when this interface enters the transmit or receive enable (READY) status, it becomes "0" (LOW level) and becomes "1" (HIGH level) when there is a BUSY status, such as during transmit/receive operation.

The SRDY signal changes the "1" to "0," immediately after writing "1" into the transmit control bit TXTRG or the receive control bit RXTRG and returns from "0" to "1", at the point where the first synchronous clock has been input (falling edge).

When you have set in the master mode, control the transfer by inputting the same signal from the slave side using the input port or I/O port. At this time, since the SRDY terminal is not set and instead P13 functions as the I/O port, you can apply this port for said control.

■ **Timing chart**

The timing chart for the clock synchronous system transmission is shown in Figure 5.8.6.4.

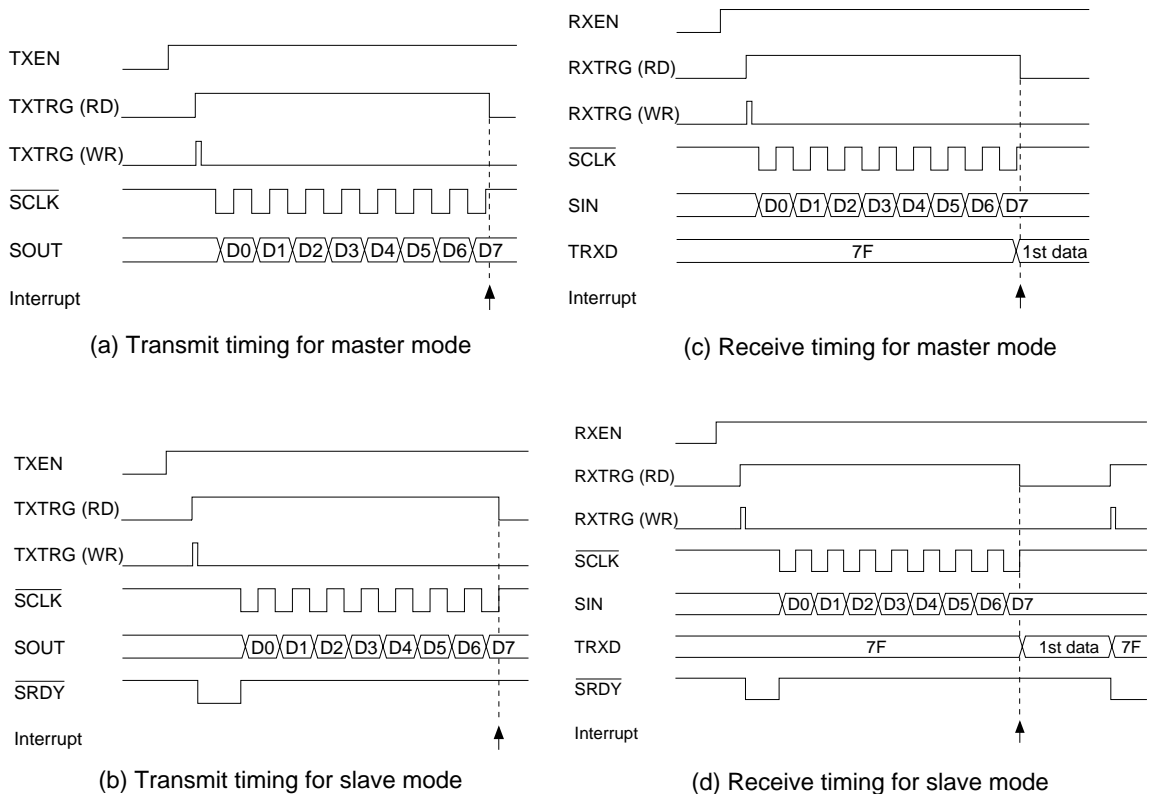

Fig. 5.8.6.4 Timing chart (clock synchronous system transmission)

### 5.8.7 Operation of asynchronous transfer

Asynchronous transfer is a mode that transfers by adding a start bit and a stop bit to the front and the back of each piece of serial converted data. In this mode, there is no need to use a clock that is fully synchronized clock on the transmit side and the receive side, but rather transmission is done while adopting the synchronization at the start/stop bits that have attached before and after each piece of data. The RS-232C interface functions can be easily realized by selecting this transfer mode.

This interface has separate transmit and receive shift registers and is designed to permit full duplex transmission to be done simultaneously for transmitting and receiving.

For transfer data in the asynchronous 7-bit mode, either 7 bits data (no parity) or 7 bits data + parity bit can be selected. In the asynchronous 8-bit mode, either 8 bits data (no parity) or 8 bits data + parity bit can be selected.

Parity can be even or odd, and parity checking of received data and adding a parity bit to transmitting data will be done automatically. Thereafter, it is not necessary to be conscious of parity itself in the program.

The start bit and stop bit are respectively fixed at one bit and data is transmitted and received by placing the LSB (bit 0) at the front.

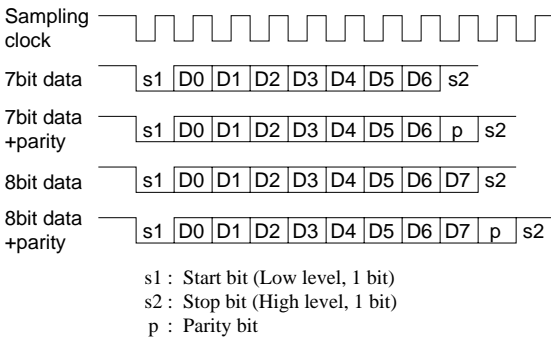

Fig. 5.8.7.1 Transfer data configuration for asynchronous system

Here following, we will explain the control sequence and operation for initialization and transmitting / receiving in case of asynchronous data transfer. See "5.8.8 Interrupt function" for the serial interface interrupts.

#### ■ Initialization of serial interface

The below initialization must be done in cases of asynchronous system transfer.

- (1) **Setting of transmitting/receiving disable**  
To set the serial interface into a status in which both transmitting and receiving are disabled, "0" must be written to both the transmit enable register TXEN and the receive enable register RXEN. Fix these two registers to a disable status until data transfer actually begins.
- (2) **Port selection**  
Because serial interface input/output terminals SIN and SOUT are set as I/O port terminals P10 and P11 at initial reset, "1" must be written to the serial interface enable register ESIF in order to set these terminals for serial interface use. SCLK and SRDY terminals set in the clock synchronous mode are not used in the asynchronous mode. These terminals function as I/O port terminals P12 and P13.
- (3) **Setting of transfer mode**  
Select the asynchronous mode by writing the data as indicated below to the two bits of the mode selection registers SMD0 and SMD1.  
**7-bit mode:** SMD0 = "0", SMD1 = "1"  
**8-bit mode:** SMD0 = "1", SMD1 = "1"
- (4) **Parity bit selection**  
When checking and adding parity bits, write "1" into the parity enable register EPR to set to "with parity check". As a result of this setting, in the asynchronous 7-bit mode, it has a 7 bits data + parity bit configuration and in the asynchronous 8-bit mode it has an 8 bits data + parity bit configuration. In this case, parity checking for receiving and adding a parity bit for transmitting is done automatically in hardware. Moreover, when "with parity check" has been selected, "odd" or "even" parity must be further selected in the parity mode selection register PMD. When "0" is written to the PMD register to select "without parity check" in the asynchronous 7-bit mode, data configuration is set to 7 bits data (no parity) and in the asynchronous 8-bit mode (no parity) it is set to 8 bits data (no parity) and parity checking and parity bit adding will not be done.
- (5) **Clock source selection**  
Select the clock source by writing data to the two bits of the clock source selection registers SCS0 and SCS1. (See Table 5.8.4.1.)

Since all the registers mentioned in (2)–(5) are assigned to the same address, it's possible to set them all with one instruction.

(6) Clock source control

When the programmable timer is selected for the clock source, set transfer rate on the programmable timer side. (See "5.11 Programmable Timer".)

When the divided signal of OSC3 oscillation circuit is selected for the clock source, be sure that the OSC3 oscillation circuit is turned ON prior to commencing data transfer. (See "5.4 Oscillation Circuit and Operating Mode".)

■ Data transmit procedure

The control procedure and operation during transmitting is as follows.

- (1) Write "0" in the transmit enable register TXEN to reset the serial interface.
- (2) Write "1" in the transmit enable register TXEN to set into the transmitting enable status.
- (3) Write the transmitting data into TRXD0–TRXD7. Also, when 7-bit data is selected, the TRXD7 data becomes invalid.
- (4) Write "1" in the transmit control bit TXTRG and start transmitting.

This control causes the shift clock to change to enable and a start bit (LOW) is output to the SOUT terminal in synchronize to its rising edge. The transmitting data set to the shift register is shifted one bit at a time at each rising edge of the clock thereafter and is output from the SOUT terminal. After the data output, it outputs a stop bit (HIGH) and HIGH level is maintained until the next start bit is output.

The transmitting complete interrupt factor flag FSTRA is set to "1" at the point where the data transmitting is completed. When interrupt has been enabled, a transmitting complete interrupt is generated at this point.

Set the following transmitting data using this interrupt.

- (5) Repeat steps (3) to (4) for the number of bytes of transmitting data, and then set the transmit disable status by writing "0" to the transmit enable register TXEN, when the transmitting is completed.

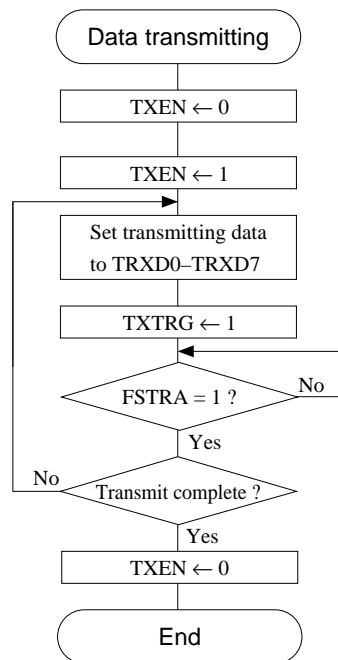

Fig. 5.8.7.2 Transmit procedure in asynchronous mode

■ **Data receive procedure**

The control procedure and operation during receiving is as follows.

- (1) Write "0" in the receive enable register RXEN to set the receiving disable status and to reset the respective PER, OER, FER flags that indicate parity, overrun and framing errors.
- (2) Write "1" in the receive enable register RXEN to set into the receiving enable status.
- (3) The shift clock will change to enable from the point where the start bit (LOW) has been input from the SIN terminal and the receive data will be synchronized to the rising edge following the second clock, and will thus be successively incorporated into the shift register.  
After data bits have been incorporated, the stop bit is checked and, if it is not HIGH, it becomes a framing error and the error interrupt factor flag FSERR is set to "1". When interrupt has been enabled, an error interrupt is generated at this point. When receiving is completed, data in the shift register is transferred to the received data buffer and the receiving complete interrupt flag FSREC is set to "1". When interrupt has been enabled, a receiving complete interrupt is generated at this point. (When an overrun error is generated, the interrupt factor flag FSREC is not set to "1" and a receiving complete interrupt is not generated.) If "with parity check" has been selected, a parity check is executed when data is transferred into the received data buffer from the shift register and if a parity error is detected, the error interrupt factor flag is set to "1". When the interrupt has been enabled, an error interrupt is generated at this point just as in the framing error mentioned above.
- (4) Read the received data from TRXD0–TRXD7 using receiving complete interrupt.
- (5) Write "1" to the receive control bit RXTRG to inform that the receive data has been read out. When the following data is received prior to writing "1" to RXTRG, it is recognized as an overrun error and the error interrupt factor flag is set to "1". When the interrupt has been enabled, an error interrupt is generated at this point just as in the framing error and parity error mentioned above.
- (6) Repeat steps (3) to (5) for the number of bytes of receiving data, and then set the receive disable status by writing "0" to the receive enable register RXEN, when the receiving is completed.

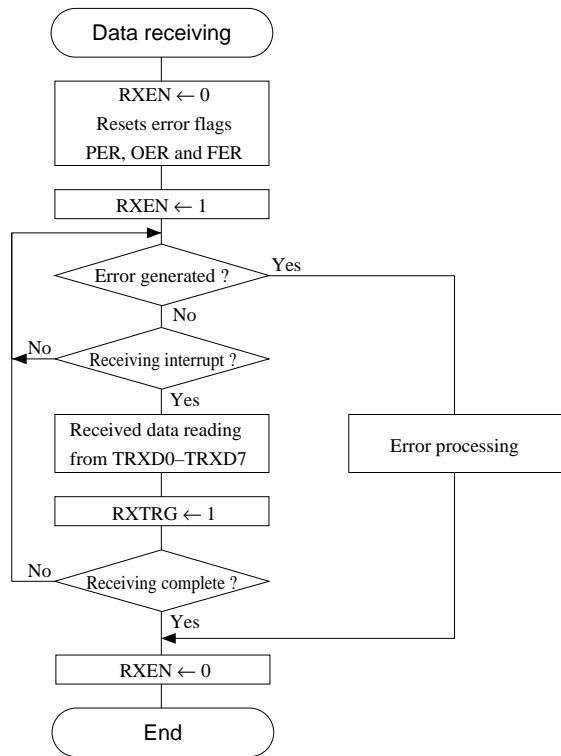

Fig. 5.8.7.3 Receiving procedure in asynchronous mode

### ■ Receive error

During receiving the following three types of errors can be detected by an interrupt.

#### (1) Parity error

When writing "1" to the EPR register to select "with parity check", a parity check (vertical parity check) is executed during receiving. After each data bit is sent a parity check bit is sent. The parity check bit is a "0" or a "1". Even parity checking will cause the sum of the parity bit and the other bits to be even. Odd parity causes the sum to be odd. This is checked on the receiving side.

The parity check is performed when data received in the shift register is transferred to the received data buffer. It checks whether the parity check bit is a "1" or a "0" (the sum of the bits including the parity bit) and the parity set in the PMD register match. When it does not match, it is recognized as a parity error and the parity error flag PER and the error interrupt factor flag FSERR is set to "1".

When interrupt has been enabled, an error interrupt is generated at this point.

The PER flag is reset to "0" by writing "1".

Even when this error has been generated, the received data corresponding to the error is transferred in the received data buffer and the receive operation also continues.

The received data at this point cannot assured because of the parity error.

#### (2) Framing error

In asynchronous transfer, synchronization is adopted for each character at the start bit ("0") and the stop bit ("1"). When receiving has been done with the stop bit set at "0", the serial interface judges the synchronization to be off and a framing error is generated. When this error is generated, the framing error flag FER and the error interrupt factor flag FSERR are set to "1". When interrupt has been enabled, an error interrupt is generated at this point. The FER flag is reset to "0" by writing "1".

Even when this error has been generated, the received data for it is loaded into the receive data buffer and the receive operation also continues. However, even when it does not become a framing error with the following data receipt, such data cannot be assured.

Even when this error has been generated, the received data corresponding to the error is transferred in the received data buffer and the receive operation also continues. However, even when it does not become a framing error with the following data receiving, such data cannot be assured.

#### (3) Overrun error

When the next data is received before "1" is written to RXTRG, an overrun error will be generated, because the previous receive data will be overwritten. When this error is generated, the overrun error flag OER and the error interrupt factor flag FSERR are set to "1". When interrupt has been enabled, an error interrupt is generated at this point. The OER flag is reset to "0" by writing "1" into it.

Even when this error has been generated, the received data corresponding to the error is transferred in the received data buffer and the receive operation also continues.

Furthermore, when the timing for writing "1" to RXTRG and the timing for the received data transfer to the received data buffer overlap, it will be recognized as an overrun error.

### ■ Timing chart

Figure 5.8.7.4 show the asynchronous transfer timing chart.

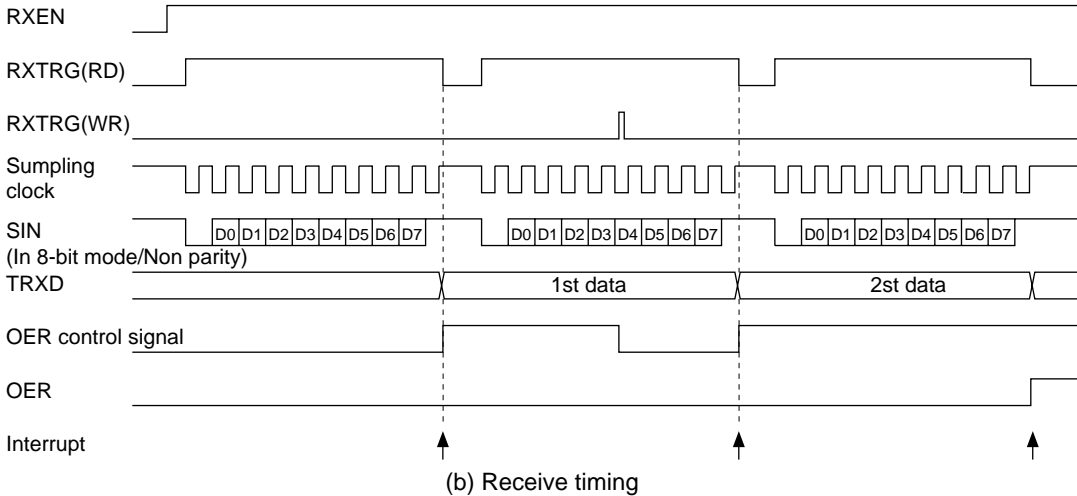
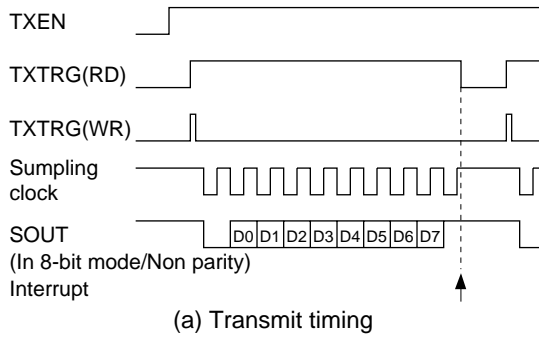

Fig. 5.8.7.4 Timing chart (asynchronous transfer)

### 5.8.8 Interrupt function

This serial interface includes a function that generates the below indicated three types of interrupts.

- Transmitting complete interrupt
- Receiving complete interrupt
- Error interrupt

The interrupt factor flag FSxxx and the interrupt enable register ESxxx for the respective interrupt factors are provided and then the interrupt enable/disable can be selected by the software. In addition, a priority level of the serial interface interrupt for the CPU can be optionally set at levels 0 to 3 by the interrupt priority registers PSIF0 and PSIF1. For details on the above mentioned interrupt control register and the operation following generation of an interrupt, see "5.16 Interrupt and Standby Status".

Figure 5.8.8.1 shows the configuration of the serial interface interrupt circuit.

#### ■ Transmitting complete interrupt

This interrupt factor is generated at the point where the sending of the data written into the shift register has been completed and sets the interrupt factor flag FSTRA to "1". When set in this manner, if the corresponding interrupt enable register ESTR A is set to "1" and the corresponding interrupt priority registers PSIF0 and PSIF1 are set to a higher level than the setting of interrupt flags (I0 and I1), an interrupt will be generated to the CPU.

When "0" has been written into the interrupt enable register ESTR A and interrupt has been disabled, an interrupt is not generated to the CPU. Even in this case, the interrupt factor flag FSTRA is set to "1". The interrupt factor flag FSTRA is reset to "0" by writing "1".

The following transmitting data can be set and the transmitting start (writing "1" to TXTRG) can be controlled by generation of this interrupt factor. The exception processing vector address for this interrupt factor is set at 000014H.

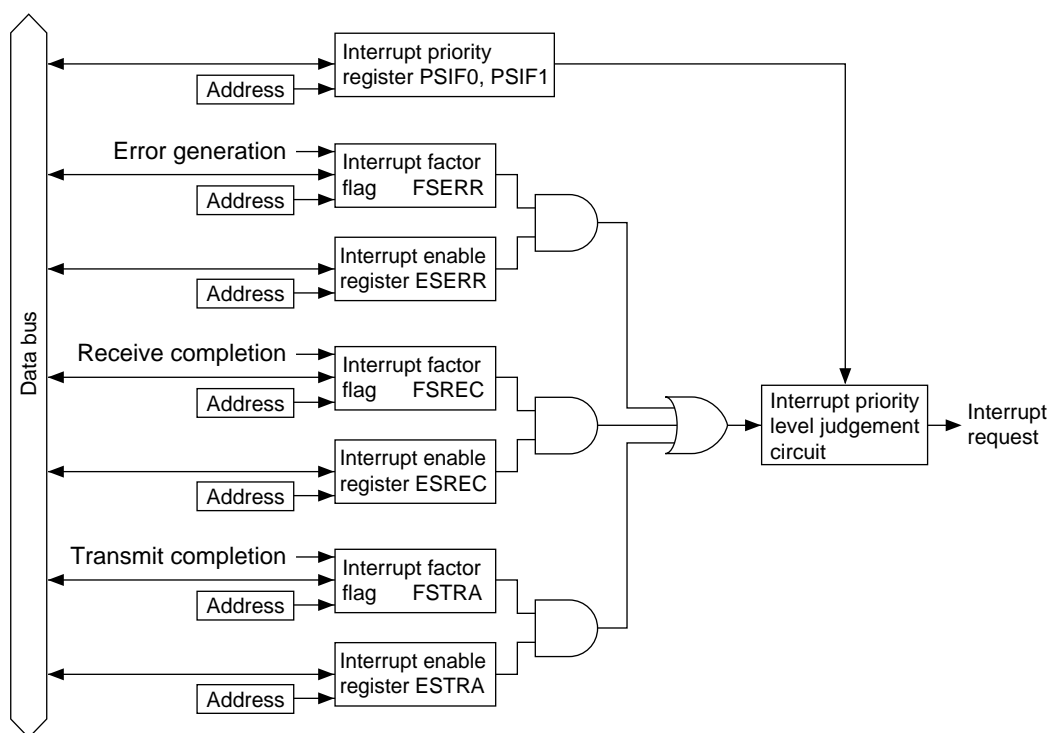

Fig. 5.8.8.1 Configuration of serial interface interrupt circuit

#### ■ Receiving complete interrupt

This interrupt factor is generated at the point where receiving has been completed and the receive data incorporated into the shift register has been transferred into the received data buffer and it sets the interrupt factor flag FSREC to "1". When set in this manner, if the corresponding interrupt enable register ESREC is set to "1" and the corresponding interrupt priority registers PSIF0 and PSIF1 are set to a higher level than the setting of interrupt flags (I0 and I1), an interrupt will be generated to the CPU. When "0" has been written into the interrupt enable register ESREC and interrupt has been disabled, an interrupt is not generated to the CPU. Even in this case, the interrupt factor flag FSREC is set to "1". The interrupt factor flag FSREC is reset to "0" by writing "1".

The generation of this interrupt factor permits the received data to be read.

Also, the interrupt factor flag is set to "1" when a parity error or framing error is generated.

The exception processing vector address for this interrupt factor is set at 000012H.

#### ■ Error interrupt

This interrupt factor is generated at the point where a parity error, framing error or overrun error is detected during receiving and it sets the interrupt factor flag FSERR to "1". When set in this manner, if the corresponding interrupt enable register ESERR is set to "1" and the corresponding interrupt priority registers PSIF0 and PSIF1 are set to a higher level than the setting of interrupt flags (I0 and I1), an interrupt will be generated to the CPU. When "0" has been written in the interrupt enable register ESERR and interrupt has been disabled, an interrupt is not generated to the CPU. Even in this case, the interrupt factor flag FSERR is set to "1". The interrupt factor flag FSERR is reset to "0" by writing "1".

Since all three types of errors result in the same interrupt factor, you should identify the error that has been generated by the error flags PER (parity error), OER (overrun error) and FER (framing error).

The exception processing vector address for this interrupt factor is set at 000010H.

## 5.8.9 Control of serial interface

Table 5.8.9.1 show the serial interface control bits.

Table 5.8.9.1(a) Serial interface control bits

Address	Bit	Name	Function	1	0	SR	R/W	Comment			
00FF48	D7	–	–	–	–	–		"0" when being read			
	D6	EPR	Parity enable register	With parity	Non parity	0	R/W	Only for asynchronous mode			
	D5	PMD	Parity mode selection	Odd	Even	0	R/W				
	D4	SCS1	Clock source selection	SCS1	SCS0	Clock source	0	R/W	In the clock synchronous slave mode, external clock is selected.		
	D3			SCS0	1					1	Programmable timer
					1					0	fosc3 / 4
	D2	SMD1	Serial I/F mode selection	SMD1	SMD0	Mode	0	R/W			
				1	1					Asynchronous 8-bit	
D1	SMD0	Serial I/F mode selection	1	0	Asynchronous 7-bit	0	R/W				
			0	1	Clock synchronous slave						
D0	ESIF	Serial I/F enable register		Serial I/F	I/O port	0	R/W				
00FF49	D7	–	–	–	–	–		"0" when being read			
	D6	FER	Framing error flag	R	Error	No error	0	R/W	Only for asynchronous mode		
				W	Reset (0)	No operation					
	D5	PER	Parity error flag	R	Error	No error	0	R/W			
				W	Reset (0)	No operation					
	D4	OER	Overrun error flag	R	Error	No error	0	R/W			
				W	Reset (0)	No operation					
	D3	RXTRG	Receive trigger/status	R	Run	Stop	0	R/W			
W				Trigger	No operation						
D2	RXEN	Receive enable		Enable	Disable	0	R/W				
D1	TXTRG	Transmit trigger/status	R	Run	Stop	0	R/W				
			W	Trigger	No operation						
D0	TXEN	Transmit enable		Enable	Disable	0	R/W				
00FF4A	D7	TRXD7	Transmit/Receive data D7 (MSB)	High	Low	X	R/W				
	D6	TRXD6	Transmit/Receive data D6								
	D5	TRXD5	Transmit/Receive data D5								
	D4	TRXD4	Transmit/Receive data D4								
	D3	TRXD3	Transmit/Receive data D3								
	D2	TRXD2	Transmit/Receive data D2								
	D1	TRXD1	Transmit/Receive data D1								
	D0	TRXD0	Transmit/Receive data D0 (LSB)								
00FF20	D7	PK01	K00–K07 interrupt priority register	PK01	PK00	0	R/W				
	D6	PK00									
	D5	PSIF1	Serial interface interrupt priority register	PSIF1	PSIF0	0	R/W				
	D4	PSIF0									
	D3	PSW1	Stopwatch timer interrupt priority register	1	1	Level 3	0		R/W		
	D2	PSW0									
D1	PTM1	Clock timer interrupt priority register	0	0	Level 1	0	R/W				
D0	PTM0										



Table 5.8.9.1(b) Serial interface control bits

Address	Bit	Name	Function	1	0	SR	R/W	Comment		
00FF23	D7	EPT1	Programmable timer 1 interrupt enable register	Interrupt enable	Interrupt disable	0	R/W			
	D6	EPT0	Programmable timer 0 interrupt enable register							
	D5	EK1	K10 and K11 interrupt enable register							
	D4	EK0H	K04–K07 interrupt enable register							
	D3	EK0L	K00–K03 interrupt enable register							
	D2	ESERR	Serial I/F (error) interrupt enable register							
	D1	ESREC	Serial I/F (receiving) interrupt enable register							
D0	ESTRA	Serial I/F (transmitting) interrupt enable register								
00FF25	D7	FPT1	Programmable timer 1 interrupt factor flag	(R)	(R)	0	R/W			
	D6	FPT0	Programmable timer 0 interrupt factor flag	Interrupt factor is generated	No interrupt factor is generated					
	D5	FK1	K10 and K11 interrupt factor flag							
	D4	FK0H	K04–K07 interrupt factor flag							
	D3	FK0L	K00–K03 interrupt factor flag	(W)	(W)					
	D2	FSERR	Serial I/F (error) interrupt factor flag						Reset	No operation
	D1	FSREC	Serial I/F (receiving) interrupt factor flag							
D0	FSTRA	Serial I/F (transmitting) interrupt factor flag								

**ESIF: 00FF48H•D0**

Sets the serial interface terminals (P10–P13).

When "1" is written: Serial input/output terminal

When "0" is written: I/O port terminal

Reading: Valid

The ESIF is the serial interface enable register and P10–P13 terminals become serial input/output terminals (SIN, SOUT, SCLK, SRDY) when "1" is written, and they become I/O port terminals when "0" is written.

Also, see Table 5.8.3.2 for the terminal settings according to the transfer modes.

At initial reset, ESIF is set to "0" (I/O port).

**SMD0, SMD1: 00FF48H•D1, D2**

Set the transfer modes according to Table 5.8.9.2.

Table 5.8.9.2 Transfer mode settings

SMD1	SMD0	Mode
1	1	Asynchronous system 8-bit
1	0	Asynchronous system 7-bit
0	1	Clock synchronous system slave
0	0	Clock synchronous system master

SMD0 and SMD1 can also read out.

At initial reset, this register is set to "0" (clock synchronous master mode).

**SCS0, SCS1: 00FF48H•D3, D4**

Select the clock source according to Table 5.8.9.3.

Table 5.8.9.3 Clock source selection

SCS1	SCS0	Clock source
1	1	Programmable timer
1	0	fosc3 / 4
0	1	fosc3 / 8
0	0	fosc3 / 16

SCS0 and SCS1 can also be read out.

In the clock synchronous slave mode, setting of this register is invalid.

At initial reset, this register is set to "0" (fosc3/16).

**EPR: 00FF48H•D6**

Selects the parity function.

When "1" is written: With parity

When "0" is written: Non parity

Reading: Valid

Selects whether or not to check parity of the received data and to add a parity bit to the transmitting data. When "1" is written to EPR, the most significant bit of the received data is considered to be the parity bit and a parity check is executed. A parity bit is added to the transmitting data. When "0" is written, neither checking is done nor is a parity bit added.

Parity is valid only in asynchronous mode and the EPR setting becomes invalid in the clock synchronous mode.

At initial reset, EPR is set to "0" (non parity).

**PMD: 00FF48H•D5**

Selects odd parity / even parity.

When "1" is written: Odd parity  
 When "0" is written: Even parity  
 Reading: Valid

When "1" is written to PMD, odd parity is selected and even parity is selected when "0" is written. The parity check and addition of a parity bit is only valid when "1" has been written to EPR. When "0" has been written to EPR, the parity setting by PMD becomes invalid.

At initial reset, PMD is set to "0" (even parity).

**TXEN: 00FF49H•D0**

Sets the serial interface to the transmitting enable status.

When "1" is written: Transmitting enable  
 When "0" is written: Transmitting disable  
 Reading: Valid

When "1" is written to TXEN, the serial interface shifts to the transmitting enable status and shifts to the transmitting disable status when "0" is written. Set TXEN to "0" when making the initial settings of the serial interface and similar operations.

At initial reset, TXEN is set to "0" (transmitting disable).

**TXTRG: 00FF49H•D1**

Functions as the transmitting start trigger and the operation status indicator (transmitting / stop status).

When "1" is read: During transmitting  
 When "0" is read: During stop  
 When "1" is written: Transmitting start  
 When "0" is written: Invalid

Starts the transmitting when "1" is written to TXTRG after writing the transmitting data. TXTRG can be read as the status. When set to "1", it indicates transmitting operation, and "0" indicates transmitting stop.

At initial reset, TXTRG is set to "0" (during stop).

**RXEN: 00FF49H•D2**

Sets the serial interface to the receiving enable status.

When "1" is written: Receiving enable  
 When "0" is written: Receiving disable  
 Reading: Valid

When "1" is written to RXEN, the serial interface shifts to the receiving enable status and shifts to the receiving disable status when "0" is written.

Set RXEN to "0" when making the initial settings of the serial interface and similar operations.

At initial reset, RXEN is set to "0" (receiving disable).

**RXTRG: 00FF49H•D3**

Functions as the receiving start trigger or preparation for the following data receiving and the operation status indicator (during receiving / during stop).

When "1" is read: During receiving  
 When "0" is read: During stop

When "1" is written: Receiving start / following data receiving preparation  
 When "0" is written: Invalid

RXTRG has a slightly different operation in the clock synchronous system and the asynchronous system.

The RXTRG in the clock synchronous system, is used as the trigger for the receiving start.

Writes "1" into RXTRG to start receiving at the point where the receive data has been read and the following receive preparation has been done. (In the slave mode, SRDY becomes "0" at the point where "1" has been written into into the RXTRG.)

RSTRG is used in the asynchronous system for preparation of the following data receiving. Reads the received data located in the received data buffer and writes "1" into RXTRG to inform that the received data buffer has shifted to empty. When "1" has not been written to RXTRG, the overrun error flag OER is set to "1" at the point where the following receiving has been completed. (When the receiving has been completed between the operation to read the received data and the operation to write "1" into RXTRG, an overrun error occurs.)

In addition, RXTRG can be read as the status. In either clock synchronous mode or asynchronous mode, when RXTRG is set to "1", it indicates receiving operation and when set to "0", it indicates that receiving has stopped.

At initial reset, RXTRG is set to "0" (during stop).

**TRXD0–TRXD7: 00FF4AH****During transmitting**

Write the transmitting data into the transmit shift register.

- When "1" is written: HIGH level
- When "0" is written: LOW level

Write the transmitting data prior to starting transmitting.

In the case of continuous transmitting, wait for the transmitting complete interrupt, then write the data. The TRXD7 becomes invalid for the asynchronous 7-bit mode.

Converted serial data for which the bits set at "1" as HIGH (VDD) level and for which the bits set at "0" as LOW (VSS) level are output from the SOUT terminal.

**During receiving**

Read the received data.

- When "1" is read: HIGH level
- When "0" is read: LOW level

The data from the received data buffer can be read out. Since the shift register is provided separately from this buffer, reading can be done during the receive operation in the asynchronous mode. (The buffer function is not used in the clock synchronous mode.) Read the data after waiting for the receiving complete interrupt.

When performing parity check in the asynchronous 7-bit mode, "0" is loaded into the 8th bit (TRXD7) that corresponds to the parity bit.

The serial data input from the SIN terminal is level converted, making the HIGH (VDD) level bit "1" and the LOW (VSS) level bit "0" and is then loaded into this buffer.

At initial reset, the buffer content is undefined.

**OER: 00FF49H•D4**

Indicates the generation of an overrun error.

- When "1" is read: Error
- When "0" is read: No error
- When "1" is written: Reset to "0"
- When "0" is written: Invalid

OER is an error flag that indicates the generation of an overrun error and becomes "1" when an error has been generated.

An overrun error is generated when the receiving of data has been completed prior to the writing of "1" to RXTRG in the asynchronous mode.

OER is reset to "0" by writing "1".

At initial reset and when RXEN is "0", OER is set to "0" (no error).

**PER: 00FF49H•D5**

Indicates the generation of a parity error.

- When "1" is read: Error
- When "0" is read: No error
- When "1" is written: Reset to "0"
- When "0" is written: Invalid

PER is an error flag that indicates the generation of a parity error and becomes "1" when an error has been generated.

When a parity check is performed in the asynchronous mode, if data that does not match the parity is received, a parity error is generated.

PER is reset to "0" by writing "1".

At initial reset and when RXEN is "0", PER is set to "0" (no error).

**FER: 00FF49H•D6**

Indicates the generation of a framing error.

- When "1" is read: Error
- When "0" is read: No error
- When "1" is written: Reset to "0"
- When "0" is written: Invalid

FER is an error flag that indicates the generation of a framing error and becomes "1" when an error has been generated.

When the stop bit for the receiving of the asynchronous mode has become "0", a framing error is generated.

FER is reset to "0" by writing "1".

At initial reset and when RXEN is "0", FER is set to "0" (no error).

**PSIF0, PSIF1: 00FF20H•D4, D5**

Sets the priority level of the serial interface interrupt. The two bits PSIF0 and PSIF1 are the interrupt priority register corresponding to the serial interface interrupt. Table 5.8.9.4 shows the interrupt priority level which can be set by this register.

Table 5.8.9.4 Interrupt priority level settings

PSIF1	PSIF0	Interrupt priority level
1	1	Level 3 ( $\overline{\text{IRQ}}3$ )
1	0	Level 2 ( $\overline{\text{IRQ}}2$ )
0	1	Level 1 ( $\overline{\text{IRQ}}1$ )
0	0	Level 0 (None)

At initial reset, this register is set to "0" (level 0).

**ESTRA, ESREC, ESERR: 00FF23H•D0, D1, D2**

Enables or disables the generation of an interrupt for the CPU.

- When "1" is written: Interrupt enabled
- When "0" is written: Interrupt disabled
- Reading: Valid

ESTRA, ESREC and ESERR are interrupt enable registers that respectively correspond to the interrupt factors for transmitting complete, receiving complete and receiving error. Interrupts set to "1" are enabled and interrupts set to "0" are disabled. At initial reset, this register is set to "0" (interrupt disabled).

**FSTRA, FSREC, FSERR: 00FF25H•D0, D1, D2**

Indicates the serial interface interrupt generation status.

- When "1" is read: Interrupt factor present
- When "0" is read: Interrupt factor not present
- When "1" is written: Resets factor flag
- When "0" is written: Invalid

FSTRA, FSREC and FSERR are interrupt factor flags that respectively correspond to the interrupts for transmitting complete, receiving complete and receiving error and are set to "1" by generation of each factor.

Transmitting complete interrupt factor is generated at the point where the data transmitting of the shift register has been completed.

Receiving complete interrupt factor is generated at the point where the received data has been transferred into the received data buffer.

Receive error interrupt factor is generated when a parity error, framing error or overrun error has been detected during data receiving.

When set in this manner, if the corresponding interrupt enable register is set to "1" and the corresponding interrupt priority register is set to a higher level than the setting of interrupt flags (I0 and I1), an interrupt will be generated to the CPU.

Regardless of the interrupt enable register and interrupt priority register settings, the interrupt factor flag will be set to "1" by the occurrence of an interrupt generation condition.

To accept the subsequent interrupt after interrupt generation, re-setting of the interrupt flags (set interrupt flag to lower level than the level indicated by the interrupt priority registers, or execute the RETE instruction) and interrupt factor flag reset are necessary. The interrupt factor flag is reset to "0" by writing "1".

At initial reset, this flag is reset to "0".

**5.8.10 Programming notes**

- (1) Be sure to initialize the serial interface mode in the transmitting / receiving disable status (TXEN = RXEN = "0").
- (2) Do not perform double trigger (writing "1" to TXTRG (RXTRG) when the serial interface is in the transmitting (receiving) operation. Furthermore, do not execute the SLP instruction. (When executing the SLP instruction, set TXEN = RXEN = "0".)
- (3) In the clock synchronous mode, since one clock line (SCLK) is shared for both transmitting and receiving, transmitting and receiving cannot be performed simultaneously. (Half duplex only is possible in clock synchronous mode.) Consequently, be sure not to write "1" to RXTRG (TXTRG) when TXTRG (RXTRG) is "1".
- (4) When a parity error or framing error is generated during receiving in the asynchronous mode, the receiving error interrupt factor flag FSERR is set to "1" prior to the receiving complete interrupt factor flag FSREC for the time indicated in Table 5.8.10.1. Consequently, when an error is generated, you should reset the receiving complete interrupt factor flag FSREC to "0" by providing a wait time in error processing routines and similar routines. When an overrun error is generated, the receiving complete interrupt factor flag FSREC is not set to "1" and a receiving complete interrupt is not generated.

*Table 5.8.10.1 Time difference between FSERR and FSREC on error generation*

Clock source	Time difference
fosc3 / n	1/2 cycles of fosc3 / n
Programmable timer	1 cycle of timer 1 underflow

- (5) When the demultiplied signal of the OSC3 oscillation circuit is made the clock source, it is necessary to turn the OSC3 oscillation ON, prior to using the serial interface. A time interval of several msec to several 10 msec, from the turning ON of the OSC3 oscillation circuit to until the oscillation stabilizes, is necessary, due to the oscillation element that is used. Consequently, you should allow an adequate waiting time after turning ON of the OSC3 oscillation, before starting transmitting / receiving of serial interface. (The oscillation start time will vary somewhat depending on the oscillator and on the externally attached parts. Refer to the oscillation start time example indicated in Chapter 7, "ELECTRICAL CHARACTERISTICS".) At initial reset, the OSC3 oscillation circuit is set to OFF status.

## 5.9 Clock Timer

### 5.9.1 Configuration of clock timer

The E0C883xx has built in a clock timer that uses the OSC1 oscillation circuit as clock source. The clock timer is composed of an 8-bit binary counter that uses the 256 Hz signal dividing  $f_{OSC1}$  as its input clock and can read the data of each bit (128–1 Hz) by software.

Normally, this clock timer is used for various timing functions such as clocks.

The configuration of the clock timer is shown in Figure 5.9.1.1.

### 5.9.2 Interrupt function

The clock timer can generate an interrupt by each of the 32 Hz, 8 Hz, 2 Hz and 1 Hz signals.

The configuration of the clock timer interrupt circuit is shown in Figure 5.9.2.1.

Interrupts are generated by respectively setting the corresponding interrupt factor flags FTM32, FTM8, FTM2 and FTM1 at the falling edge of the 32 Hz, 8 Hz, 2 Hz and 1 Hz signals to "1". Interrupt can be prohibited by the setting the interrupt enable registers ETM32, ETM8, ETM2 and ETM1 corresponding to each interrupt factor flag.

In addition, a priority level of the clock timer interrupt for the CPU can be optionally set at levels 0 to 3 by the interrupt priority registers PTM0 and PTM1.

For details on the above mentioned interrupt control register and the operation following generation of an interrupt, see "5.16 Interrupt and Standby Status".

The exception processing vector addresses for each interrupt factor are respectively set as shown below.

32 Hz interrupt:	00001CH
8 Hz interrupt:	00001EH
2 Hz interrupt:	000020H
1 Hz interrupt:	000022H

Figure 5.9.2.2 shows the timing chart for the clock timer.

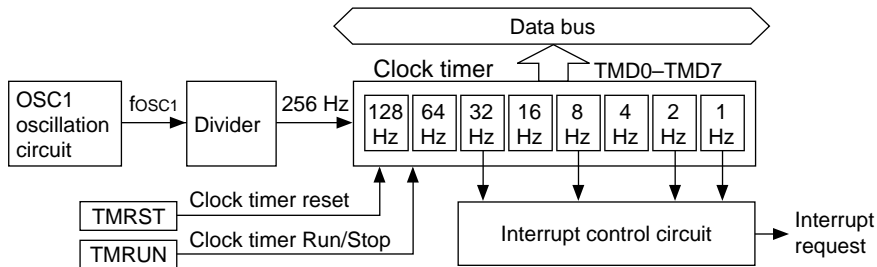

Fig. 5.9.1.1 Configuration of clock timer

5 PERIPHERAL CIRCUITS AND THEIR OPERATION (Clock Timer)

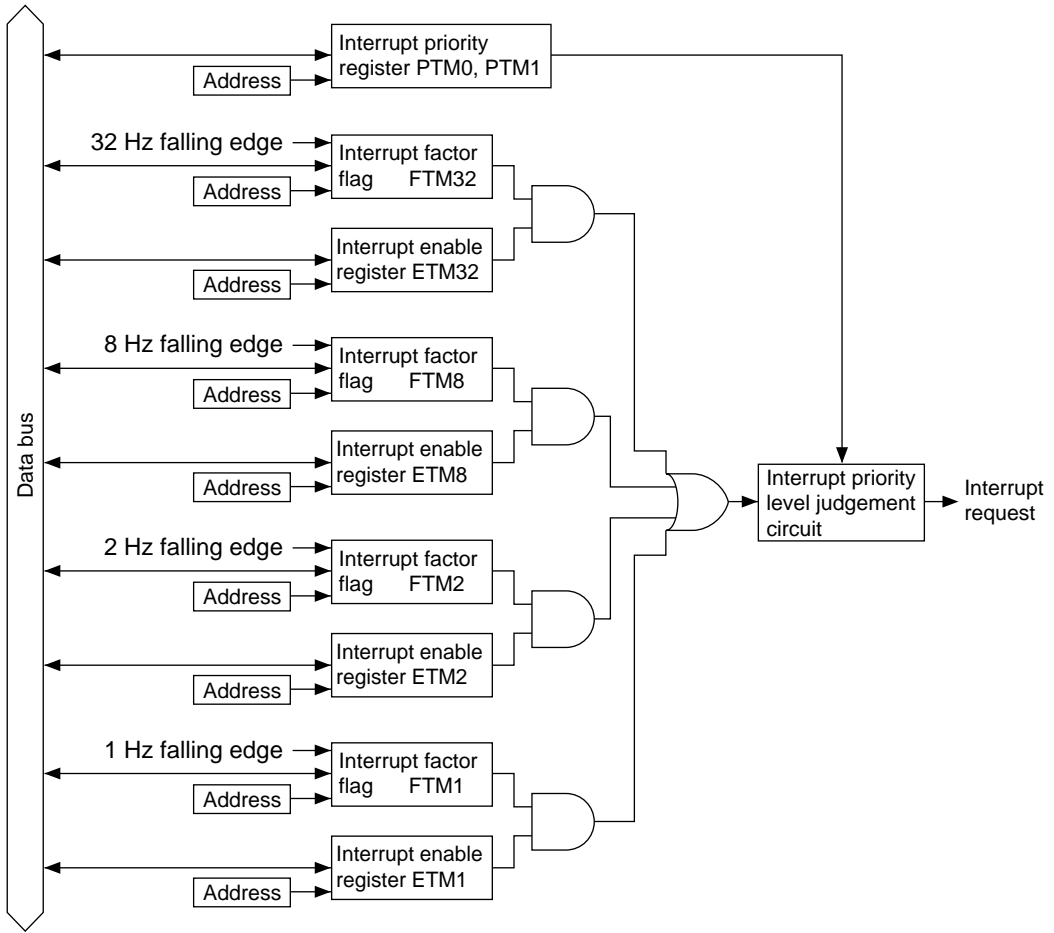

Fig. 5.9.2.1 Configuration of clock timer interrupt circuit

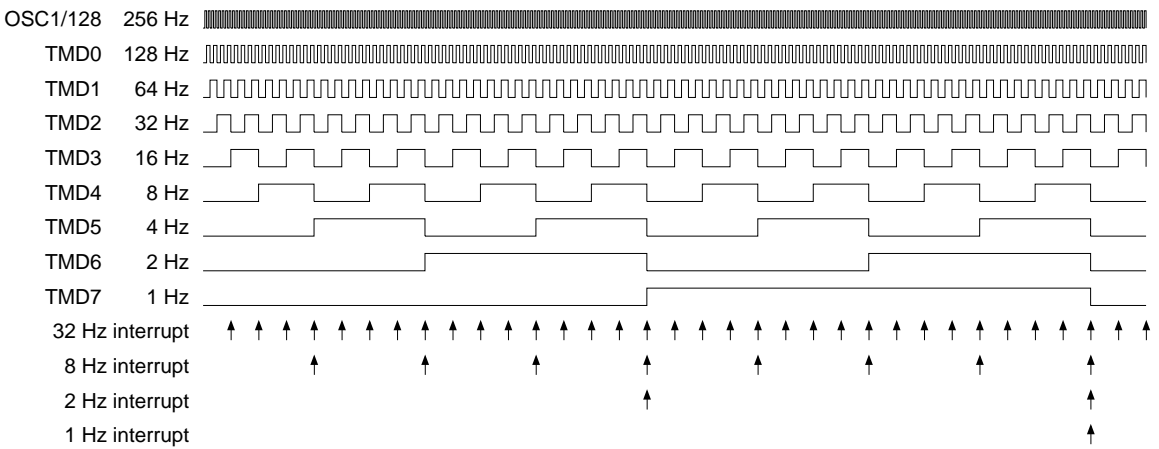

Fig. 5.9.2.2 Timing chart of clock timer

## 5.9.3 Control of clock timer

Table 5.9.3.1 shows the clock timer control bits.

Table 5.9.3.1 Clock timer control bits

Address	Bit	Name	Function	1	0	SR	R/W	Comment																																				
00FF40	D7	—	—	—	—	—		"0" when being read																																				
	D6	FOUT2	FOUT frequency selection <table border="1"> <thead> <tr> <th>FOUT2</th> <th>FOUT1</th> <th>FOUT0</th> <th>Frequency</th> </tr> </thead> <tbody> <tr> <td>0</td> <td>0</td> <td>0</td> <td>fosc1 / 1</td> </tr> <tr> <td>0</td> <td>0</td> <td>1</td> <td>fosc1 / 2</td> </tr> <tr> <td>0</td> <td>1</td> <td>0</td> <td>fosc1 / 4</td> </tr> <tr> <td>0</td> <td>1</td> <td>1</td> <td>fosc1 / 8</td> </tr> <tr> <td>1</td> <td>0</td> <td>0</td> <td>fosc3 / 1</td> </tr> <tr> <td>1</td> <td>0</td> <td>1</td> <td>fosc3 / 2</td> </tr> <tr> <td>1</td> <td>1</td> <td>0</td> <td>fosc3 / 4</td> </tr> <tr> <td>1</td> <td>1</td> <td>1</td> <td>fosc3 / 8</td> </tr> </tbody> </table>	FOUT2	FOUT1	FOUT0	Frequency	0	0	0	fosc1 / 1	0	0	1	fosc1 / 2	0	1	0	fosc1 / 4	0	1	1	fosc1 / 8	1	0	0	fosc3 / 1	1	0	1	fosc3 / 2	1	1	0	fosc3 / 4	1	1	1	fosc3 / 8			0	R/W	
	FOUT2	FOUT1		FOUT0	Frequency																																							
	0	0		0	fosc1 / 1																																							
	0	0	1	fosc1 / 2																																								
	0	1	0	fosc1 / 4																																								
	0	1	1	fosc1 / 8																																								
	1	0	0	fosc3 / 1																																								
	1	0	1	fosc3 / 2																																								
1	1	0	fosc3 / 4																																									
1	1	1	fosc3 / 8																																									
D5	FOUT1				0	R/W																																						
D4	FOUT0					0	R/W																																					
D3	FOUTON	FOUT output control		On	Off	0	R/W																																					
D2	WDRST	Watchdog timer reset		Reset	No operation	—	W	Constantly "0" when																																				
D1	TMRST	Clock timer reset		Reset	No operation	—	W	being read																																				
D0	TMRUN	Clock timer Run/Stop control		Run	Stop	0	R/W																																					
00FF41	D7	TMD7	Clock timer data 1 Hz	High	Low	0	R																																					
	D6	TMD6	Clock timer data 2 Hz																																									
	D5	TMD5	Clock timer data 4 Hz																																									
	D4	TMD4	Clock timer data 8 Hz																																									
	D3	TMD3	Clock timer data 16 Hz																																									
	D2	TMD2	Clock timer data 32 Hz																																									
	D1	TMD1	Clock timer data 64 Hz																																									
	D0	TMD0	Clock timer data 128 Hz																																									
00FF20	D7	PK01	K00–K07 interrupt priority register	PK01	PK00	0	R/W																																					
	D6	PK00																																										
	D5	PSIF1	Serial interface interrupt priority register	PSIF1	PSIF0	0	R/W																																					
	D4	PSIF0																																										
	D3	PSW1																																										
	D2	PSW0	Stopwatch timer interrupt priority register	PTM1	PTM0	Priority level	0	R/W																																				
	D1	PTM1	Clock timer interrupt priority register	1	1	Level 3	0	R/W																																				
D0	PTM0	1		0	Level 2																																							
			0	1	Level 1																																							
			0	0	Level 0																																							
00FF22	D7	—	—	—	—	—		"0" when being read																																				
	D6	ESW100	Stopwatch timer 100 Hz interrupt enable register	Interrupt enable	Interrupt disable	0	R/W																																					
	D5	ESW10	Stopwatch timer 10 Hz interrupt enable register																																									
	D4	ESW1	Stopwatch timer 1 Hz interrupt enable register																																									
	D3	ETM32	Clock timer 32 Hz interrupt enable register																																									
	D2	ETM8	Clock timer 8 Hz interrupt enable register																																									
	D1	ETM2	Clock timer 2 Hz interrupt enable register																																									
	D0	ETM1	Clock timer 1 Hz interrupt enable register																																									
00FF24	D7	—	—						—	—	—		"0" when being read																															
	D6	FSW100	Stopwatch timer 100 Hz interrupt factor flag	(R)	(R)	0	R/W																																					
	D5	FSW10	Stopwatch timer 10 Hz interrupt factor flag	Interrupt factor is generated	No interrupt factor is generated																																							
	D4	FSW1	Stopwatch timer 1 Hz interrupt factor flag																																									
	D3	FTM32	Clock timer 32 Hz interrupt factor flag	(W)	(W)																																							
	D2	FTM8	Clock timer 8 Hz interrupt factor flag	Reset	No operation																																							
	D1	FTM2	Clock timer 2 Hz interrupt factor flag																																									
D0	FTM1	Clock timer 1 Hz interrupt factor flag																																										

**TMD0–TMD7: 00FF41H**

The clock timer data can be read out. Each bit of TMD0–TMD7 and frequency correspondence are as follows:

- TMD0: 128Hz      TMD4: 8Hz
- TMD1: 64Hz      TMD5: 4Hz
- TMD2: 32Hz      TMD6: 2Hz
- TMD3: 16Hz      TMD7: 1Hz

Since the TMD0–TMD7 is exclusively for reading, the write operation is invalid.

At initial reset, the timer data is set to "00H".

**TMRST: 00FF40H•D1**

Resets the clock timer.

- When "1" is written: Clock timer reset
- When "0" is written: No operation
- Reading: Always "0"

The clock timer is reset by writing "1" to the TMRST.

When the clock timer is reset in the RUN status, it restarts immediately after resetting. In the case of the STOP status, the reset data "00H" is maintained. No operation results when "0" is written to the TMRST.

Since the TMRST is exclusively for writing, it always becomes "0" during reading.

**TMRUN: 00FF40H•D0**

Controls RUN/STOP of the clock timer.

- When "1" is written: RUN
- When "0" is written: STOP
- Reading: Valid

The clock timer starts up-counting by writing "1" to the TMRUN and stops by writing "0".

In the STOP status, the count data is maintained until it is reset or set in the next RUN status. Also, when the STOP status changes to the RUN status, the data that was maintained can be used for resuming the count.

At initial reset, the TMRUN is set to "0" (STOP).

**PTM0, PTM1: 00FF20H•D0, D1**

Sets the priority level of the clock timer interrupt. The two bits PTM0 and PTM1 are the interrupt priority register corresponding to the clock timer interrupt. Table 5.9.3.2 shows the interrupt priority level which can be set by this register.

Table 5.9.3.2 Interrupt priority level settings

PTM1	PTM0	Interrupt priority level
1	1	Level 3 ( $\overline{IRQ3}$ )
1	0	Level 2 ( $\overline{IRQ2}$ )
0	1	Level 1 ( $\overline{IRQ1}$ )
0	0	Level 0 (None)

At initial reset, this register is set to "0" (level 0).

**ETM1, ETM2, ETM8, ETM32: 00FF22H•D0–D3**

Enables or disables the generation of an interrupt for the CPU.

- When "1" is written: Interrupt enabled
- When "0" is written: Interrupt disabled
- Reading: Valid

The ETM1, ETM2, ETM8 and ETM32 are interrupt enable registers that respectively correspond to the interrupt factors for 1 Hz, 2 Hz, 8 Hz and 32 Hz. Interrupts set to "1" are enabled and interrupts set to "0" are disabled.

At initial reset, this register is set to "0" (interrupt disabled).

**FTM1, FTM2, FTM8, FTM32: 00FF24H•D0–D3**

Indicates the clock timer interrupt generation status.

- When "1" is read: Interrupt factor present
- When "0" is read: Interrupt factor not present
- When "1" is written: Resets factor flag
- When "0" is written: Invalid

The FTM1, FTM2, FTM8 and FTM32 are interrupt factor flags that respectively correspond to the interrupts for 1 Hz, 2 Hz, 8 Hz and 32 Hz and are set to "1" at the falling edge of each signal.

When set in this manner, if the corresponding interrupt enable register is set to "1" and the corresponding interrupt priority register is set to a higher level than the setting of interrupt flags (I0 and I1), an interrupt will be generated to the CPU. Regardless of the interrupt enable register and interrupt priority register settings, the interrupt factor flag will be set to "1" by the occurrence of an interrupt generation condition.

To accept the subsequent interrupt after interrupt generation, re-setting of the interrupt flags (set interrupt flag to lower level than the level indicated by the interrupt priority registers, or execute the RETE instruction) and interrupt factor flag reset are necessary. The interrupt factor flag is reset to "0" by writing "1".

At initial reset, this flag is reset to "0".



### 5.9.4 Programming notes

- (1) The clock timer is actually made to RUN/STOP in synchronization with the falling edge of the 256 Hz signal after writing to the TMRUN register. Consequently, when "0" is written to the TMRUN, the timer shifts to STOP status when the counter is incremented "1". The TMRUN maintains "1" for reading until the timer actually shifts to STOP status. Figure 5.9.4.1 shows the timing chart of the RUN/STOP control.

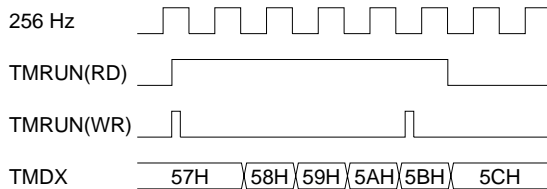

Fig. 5.9.4.1 Timing chart of RUN/STOP control

- (2) The SLP instruction is executed when the clock timer is in the RUN status (TMRUN = "1"). The clock timer operation will become unstable when returning from SLEEP status. Therefore, when shifting to SLEEP status, set the clock timer to STOP status (TMRUN = "0") prior to executing the SLP instruction.

## 5.10 Stopwatch Timer

### 5.10.1 Configuration of stopwatch timer

The E0C883xx has a built-in 1/100 sec and 1/10 sec stopwatch timer. The stopwatch timer is composed of a 4-bit 2 stage BCD counter (1/100 sec units and 1/10 sec units) that makes the 256 Hz signal that divides the fosc1 the input clock and it can read the count data by software.

Figure 5.10.1.1 shows the configuration of the stopwatch timer.

The stopwatch timer can be used as a timer different from the clock timer and can easily realize stopwatch and other such functions by software.

### 5.10.2 Count up pattern

The stopwatch timer is respectively composed of the 4-bit BCD counters SWD0–SWD3 and SWD4–SWD7.

Figure 5.10.2.1 shows the count up pattern of the stopwatch timer.

The feedback dividing circuit generates an approximate 100 Hz signal at 2/256 sec and 3/256 sec intervals from a 256 Hz signal divided from fosc1.

The 1/100 sec counter (SWD0–SWD3) generates an approximate 10 Hz signal at 25/256 sec and 26/256 sec intervals by counting the approximate 100 Hz signal generated by the feedback dividing circuit in 2/256 sec and 3/256 sec intervals. The count-up is made approximately 1/100 sec counting by the 2/256 sec and 3/256 sec intervals.

The 1/10 sec counter (SWD4–SWD7) generates a 1 Hz signal by counting the approximate 10 Hz signal generated by the 1/100 sec counter at 25/256 sec and 26/256 sec intervals in 4:6 ratios.

The count-up is made approximately 1/10 sec counting by 25/256 sec and 26/256 sec intervals.

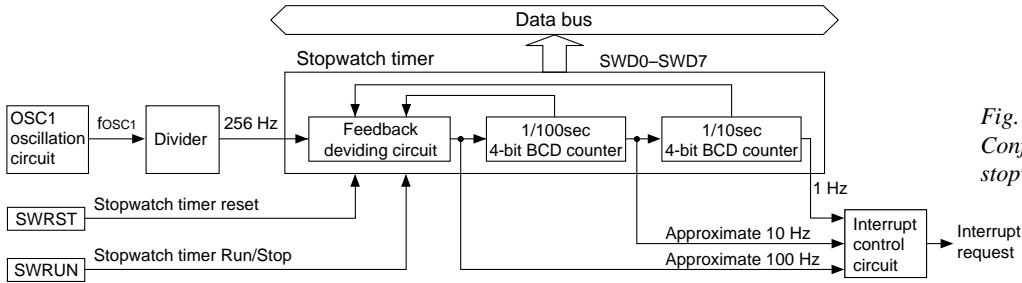

Fig. 5.10.1.1 Configuration of stopwatch timer

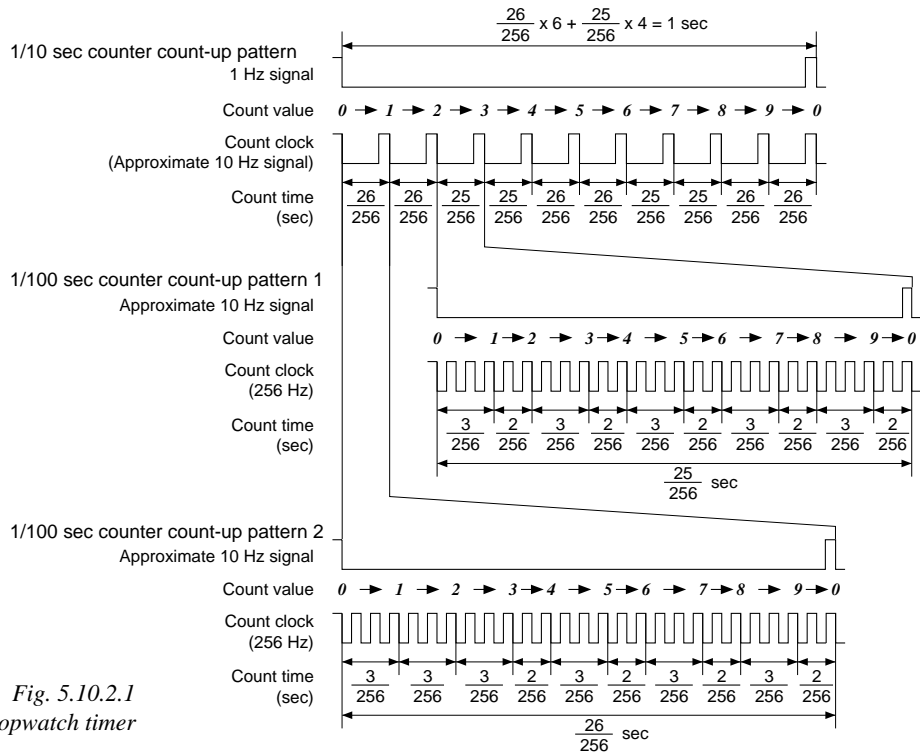

Fig. 5.10.2.1

Count-up pattern of stopwatch timer

### 5.10.3 Interrupt function

The stopwatch timer can generate an interrupt by each of the 100 Hz (approximately 100 Hz), 10 Hz (approximately 10 Hz) and 1 Hz signals.

Figure 5.10.3.1 shows the configuration of the stopwatch timer interrupt circuit

The corresponding factor flags FSW100, FSW10 and FSW1 are respectively set to "1" at the falling edge of the 100 Hz, 10Hz and 1Hz signal and an interrupt is generated. Interrupt can be prohibited by the setting of the interrupt enable registers ESW100, ESW10 and ESW1 corresponding to each interrupt factor flag.

In addition, a priority level of the stopwatch timer interrupt for the CPU can be optionally set at levels 0 to 3 by the interrupt priority registers PSW0 and PSW1.

For details on the above mentioned interrupt control registers and the operation following generation of an interrupt, see "5.16 Interrupt and Standby Status".

The exception processing vector addresses of each interrupt factor are respectively set as shown below.

- 100 Hz interrupt: 000016H
- 10 Hz interrupt: 000018H
- 1 Hz interrupt: 00001AH

Figure 5.10.3.2 shows the timing chart for the stopwatch timer.

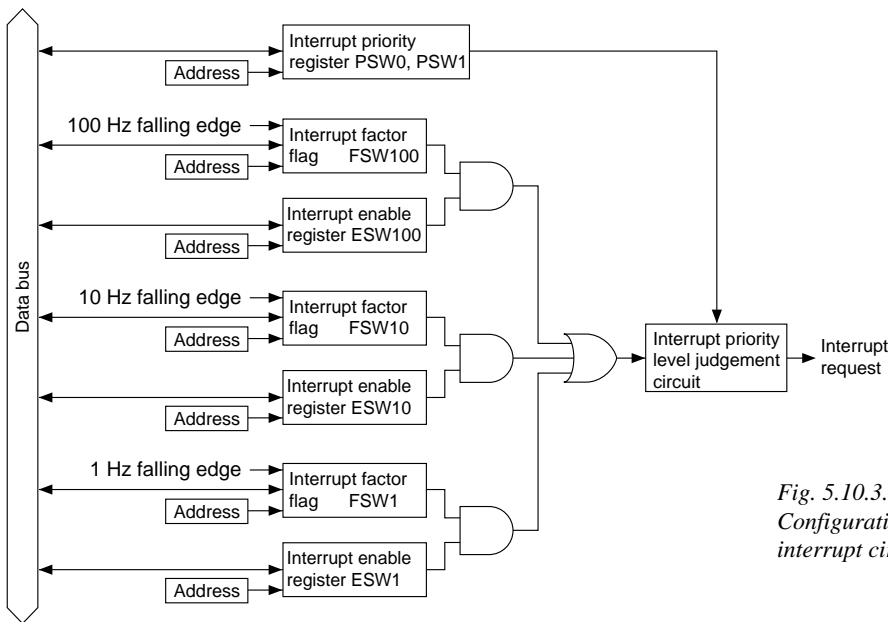

Fig. 5.10.3.1 Configuration of the stopwatch timer interrupt circuit

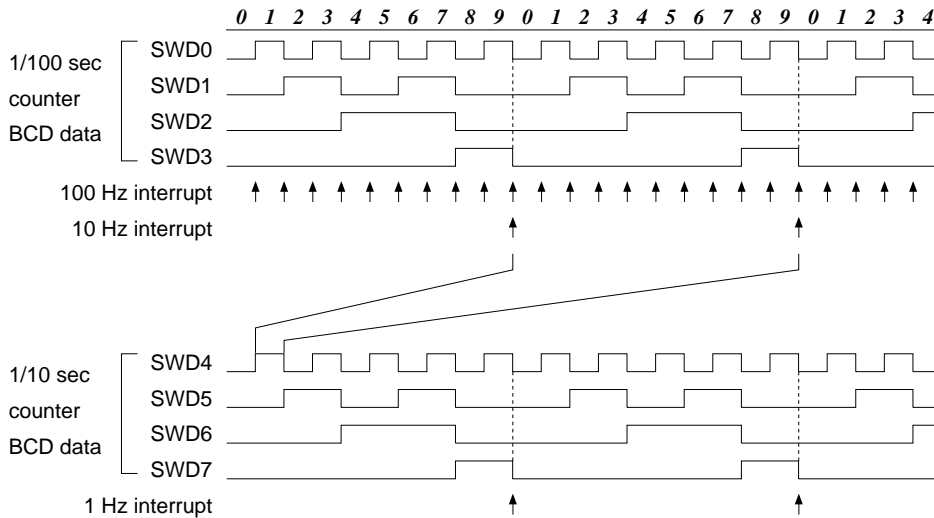

Fig. 5.10.3.2 Stopwatch timer timing chart

## 5.10.4 Control of stopwatch timer

Table 5.10.4.1 shows the stopwatch timer control bits.

Table 5.10.4.1 Stopwatch timer control bits

Address	Bit	Name	Function	1	0	SR	R/W	Comment
00FF42	D7	–	–	–	–	–		Constantly "0" when being read
	D6	–	–	–	–	–		
	D5	–	–	–	–	–		
	D4	–	–	–	–	–		
	D3	–	–	–	–	–		
	D2	–	–	–	–	–		
	D1	SWRST	Stopwatch timer reset	Reset	No operation	–	W	
D0	SWRUN	Stopwatch timer Run/Stop control	Run	Stop	0	R/W		
00FF43	D7	SWD7	Stopwatch timer data			0	R	
	D6	SWD6						
	D5	SWD5	BCD (1/10 sec)					
	D4	SWD4	-----					
	D3	SWD3	Stopwatch timer data					
	D2	SWD2	-----					
	D1	SWD1	BCD (1/100 sec)					
D0	SWD0	-----						
00FF20	D7	PK01	K00–K07 interrupt priority register	PK01 PK00 PSIF1 PSIF0 PSW1 PSW0 PTM1 PTM0	Priority level Level 3 Level 2 Level 1 Level 0	0	R/W	
	D6	PK00						
	D5	PSIF1	Serial interface interrupt priority register					
	D4	PSIF0						
	D3	PSW1	Stopwatch timer interrupt priority register					
	D2	PSW0						
D1	PTM1	Clock timer interrupt priority register						
D0	PTM0							
00FF22	D7	–	–	–	–	–		"0" when being read
	D6	ESW100	Stopwatch timer 100 Hz interrupt enable register	Interrupt enable	Interrupt disable	0	R/W	
	D5	ESW10	Stopwatch timer 10 Hz interrupt enable register					
	D4	ESW1	Stopwatch timer 1 Hz interrupt enable register					
	D3	ETM32	Clock timer 32 Hz interrupt enable register					
	D2	ETM8	Clock timer 8 Hz interrupt enable register					
	D1	ETM2	Clock timer 2 Hz interrupt enable register					
D0	ETM1	Clock timer 1 Hz interrupt enable register						
00FF24	D7	–	–	–	–	–		"0" when being read
	D6	FSW100	Stopwatch timer 100 Hz interrupt factor flag	(R)	(R)	0	R/W	
	D5	FSW10	Stopwatch timer 10 Hz interrupt factor flag	Interrupt factor is generated	No interrupt factor is generated			
	D4	FSW1	Stopwatch timer 1 Hz interrupt factor flag					
	D3	FTM32	Clock timer 32 Hz interrupt factor flag					
	D2	FTM8	Clock timer 8 Hz interrupt factor flag					
	D1	FTM2	Clock timer 2 Hz interrupt factor flag					
D0	FTM1	Clock timer 1 Hz interrupt factor flag	(W) Reset	(W) No operation				

**SWD0–SWD7: 00FF43H**

The stopwatch timer data can be read out. Higher and lower nibbles and BCD digit correspondence are as follows:

SWD0–SWD3: BCD (1/100sec)  
SWD4–SWD7: BCD (1/10sec)

Since SWD0–SWD7 are exclusively for reading, the write operation is invalid.

At initial reset, the timer data is set to "00H".

**SWRST: 00FF42H•D1**

Resets the stopwatch timer.

When "1" is written: Stopwatch timer reset  
When "0" is written: No operation  
Reading: Always "0"

The stopwatch timer is reset by writing "1" to the SWRST. When the stopwatch timer is reset in the RUN status, it restarts immediately after resetting. In the case of the STOP status, the reset data "00H" is maintained.

No operation results when "0" is written to the SWRST.

Since the SWRST is exclusively for writing, it always becomes "0" during reading.

**SWRUN: 00FF42H•D0**

Controls RUN/STOP of the stopwatch timer.

When "1" is written: RUN  
When "0" is written: STOP  
Reading: Valid

The stopwatch timer starts up-counting by writing "1" to the SWRUN and stops by writing "0".

In the STOP status, the timer data is maintained until it is reset or set in the next RUN status. Also, when the STOP status changes to the RUN status, the data that was maintained can be used for resuming the count.

At initial reset, the SWRUN is set at "0" (STOP).

**PSW0, PSW1: 00FF20H•D2, D3**

Sets the priority level of the stopwatch timer interrupt.

The two bits PSW0 and PSW1 are the interrupt priority register corresponding to the stopwatch timer interrupt. Table 5.10.4.2 shows the interrupt priority level which can be set by this register.

Table 5.10.4.2 Interrupt priority level settings

PSW1	PSW0	Interrupt priority level
1	1	Level 3 ( $\overline{\text{IRQ3}}$ )
1	0	Level 2 ( $\overline{\text{IRQ2}}$ )
0	1	Level 1 ( $\overline{\text{IRQ1}}$ )
0	0	Level 0 (None)

At initial reset, this register is set to "0" (level 0).

**ESW1, ESW10, ESW100: 00FF22H•D4, D5, D6**

Enables or disables the generation of an interrupt for the CPU.

When "1" is written: Interrupt enabled  
When "0" is written: Interrupt disabled  
Reading: Valid

The ESW1, ESW10 and ESW100 are interrupt enable registers that respectively correspond to the interrupt factors for 1 Hz, 10 Hz and 100 Hz.

Interrupts set to "1" are enabled and interrupts set to "0" are disabled.

At initial reset, this register is set to "0" (interrupt disabled).

**FSW1, FSW10, FSW100: 00FF24H•D4, D5, D6**

Indicates the stopwatch timer interrupt generation status.

When "1" is read: Interrupt factor present  
When "0" is read: Interrupt factor not present  
When "1" is written: Resets factor flag  
When "0" is written: Invalid

The FSW1, FSW10 and FSW100 are interrupt factor flags that respectively correspond to the interrupts for 1 Hz, 10 Hz and 100 Hz and are set to "1" in synchronization with the falling edge of each signal. When set in this manner, if the corresponding interrupt enable register is set to "1" and the corresponding interrupt priority register is set to a higher level than the setting of interrupt flags (I0 and I1), an interrupt will be generated to the CPU. Regardless of the interrupt enable register and interrupt priority register settings, the interrupt factor flag will be set to "1" by the occurrence of an interrupt generation condition.

To accept the subsequent interrupt after interrupt generation, re-setting of the interrupt flags (set interrupt flag to lower level than the level indicated by the interrupt priority registers, or execute the RETE instruction) and interrupt factor flag reset are necessary. The interrupt factor flag is reset to "0" by writing "1".

At initial reset, this flag is reset to "0".

**5.10.5 Programming notes**

- (1) The stopwatch timer is actually made to RUN/STOP in synchronization with the falling edge of the 256 Hz signal after writing to the SWRUN register. Consequently, when "0" is written to the SWRUN, the timer shifts to STOP status when the counter is incremented "1". The SWRUN maintains "1" for reading until the timer actually shifts to STOP status. Figure 5.10.5.1 shows the timing chart of the RUN/STOP control.

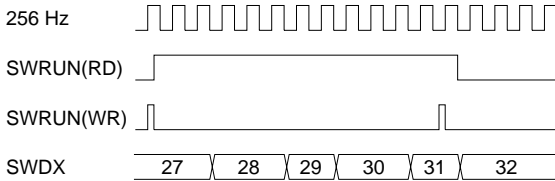

*Fig. 5.10.5.1 Timing chart of RUN/STOP control*

- (2) The SLP instruction is executed when the stopwatch timer is in the RUN status (SWRUN = "1"). The stopwatch timer operation will become unstable when returning from SLEEP status. Therefore, when shifting to SLEEP status, set the clock timer to STOP status (SWRUN = "0") prior to executing the SLP instruction.

## 5.11 Programmable Timer

### 5.11.1 Configuration of programmable timer

The E0C883xx has two built-in 8-bit programmable timer systems (timer 0 and timer 1).

Timer 0 and timer 1 are composed of 8-bit presetable down counters and they can be used as 8-bit  $\times$  2 channels or 16-bit  $\times$  1 channel programmable timer. They also have an event counter function and a pulse width measurement function using the K10 input port terminal.

Figure 5.11.1.1 shows the configuration of the programmable timer.

Programmable setting of the transfer rate is possible, due to the fact that the programmable timer underflow signal can be used as a synchronous clock for the serial interface.

The underflow divided by 1/2 signal can also be output externally from the R27 output port terminal.

### 5.11.2 Count operation and setting basic mode

Here we will explain the basic operation and setting of the programmable timer.

#### ■ Setting of initial value and counting down

The timers 0 and 1 each have a down counter and reload data register.

The reload data registers RLD00–RLD07 (timer 0) and RLD10–RLD17 (timer 1) are registers that set the initial value of the counter.

By writing "1" to the preset control bit PSET0 (timer 0) or PSET1 (timer 1), the down counter loads the initial value set in the reload register RLD.

Therefore, down-counting is executed from the stored initial value according to the input clock.

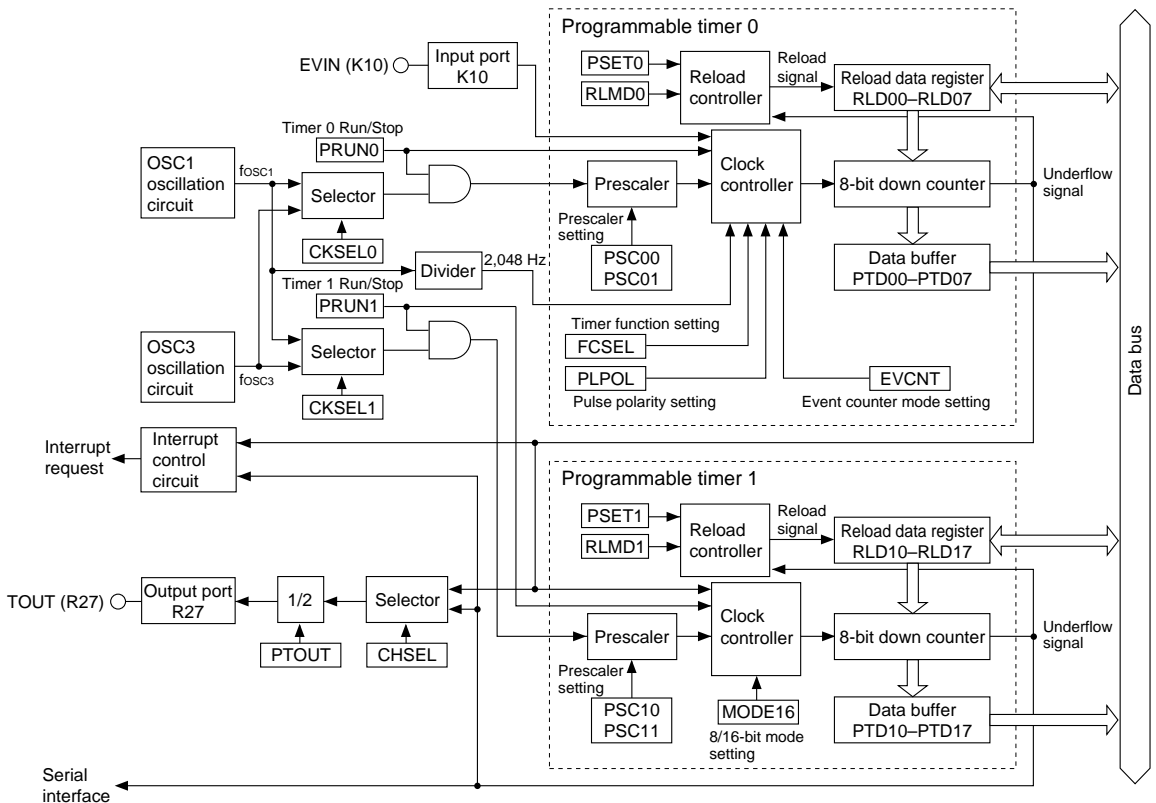

Fig. 5.11.1.1 Configuration of programmable timer

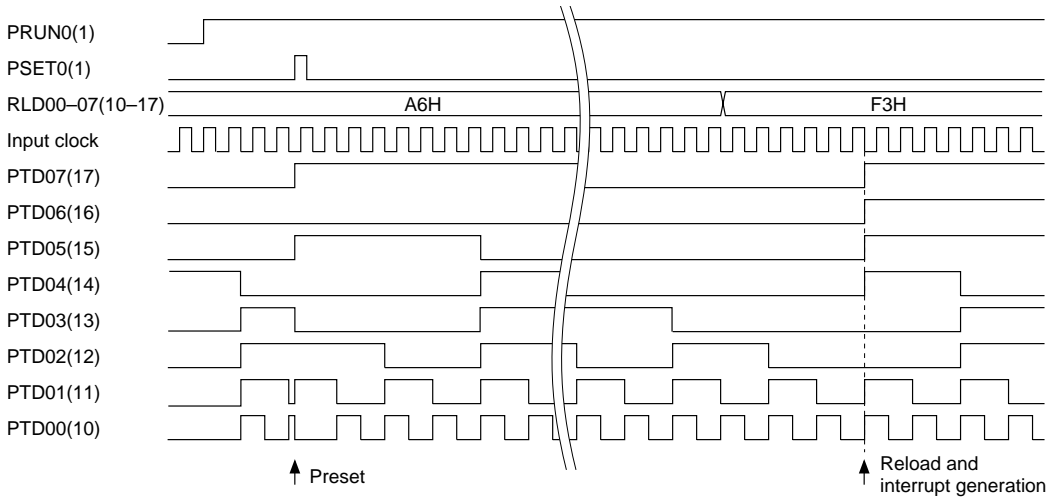

Fig. 5.11.2.1 Basic operation timing of the counter

The registers PRUN0 (timer 0) and PRUN1 (timer 1) are provided to control the RUN/STOP for timers 0 and 1.

After the reload data has been preset into the counter, down-counting is begun by writing "1" to this register. When "0" is written, the clock input is prohibited and the count stops. The control of this RUN/STOP has no affect on the counter data. The counter data is maintained even during the stoppage of the counter and it can start the count, continuing from that data.

The reading of the counter data can be done through the data buffers PTD00-PTD07 (timer 0) and PTD10-PTD17 (timer 1) with optional timing. When the down-counting has progressed and an underflow is generated, the counter reloads the initial value set in the reload data register. This underflow signal controls an interrupt generation, pulse (TOUT signal) output and serial interface clocking, in addition to reloading the counter.

■ Continuous/one-shot mode setting

By writing "1" to the continuous/one-shot mode selection registers CONT0 (timer 0) and CONT1 (timer 1), the programmable timer is set to the continuous mode. In the continuous mode, the initial counter value is automatically loaded when an underflow is generated, and counting is continued. This mode is suitable when programmable intervals are necessary (such as an interrupt and a synchronous clock for the serial interface). On the other hand, when writing "0" to the registers CONT0 (timer 0) and CONT1 (timer 1), the programmable timer is set to the one-shot mode. The counter loads an initial value and stops when an underflow is generated. At this time, the RUN/STOP control register PRUN0 (timer 0) and PRUN1 (timer 1) are automatically reset to "0". After the counter stops, a one-shot count can be performed once again by writing "1" to registers PRUN0 (timer 0) and PRUN1 (timer 1). This mode is suitable for single time measurement, for example.

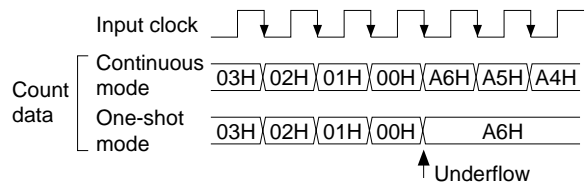

When "A6H" is set into reload data register RLD.

Fig. 5.11.2.2 Continuous mode and one-shot mode



### ■ 8/16-bit mode setting

By writing "0" to the 8/16-bit mode selection register MODE16, timer 0 and timer 1 are set as independent timers in 8-bit × 2 channels. In this mode, timer 0 and timer 1 can be controlled individually and each of them operates independently.

On the other hand, when writing "1" to the register MODE16, timer 0 and timer 1 are set as 1 channel 16-bit timer. This is done by setting timer 0 to the lower 8 bits, and timer 1 to the upper 8 bits. The timer is controlled by timer 0's registers. In this case, the control registers for timer 1 are invalid. (PRUN1 is fixed at "0".)

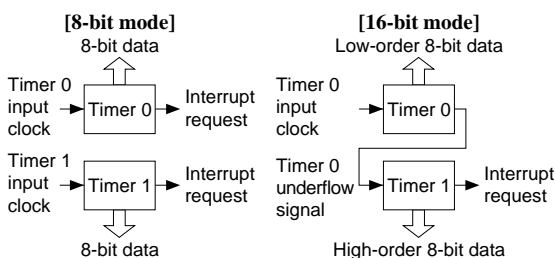

Fig. 5.11.2.3 8/16-bit mode setting and counter configuration

### 5.11.3 Setting of input clock

Prescalers have been provided for timers 0 and 1. The prescalers generate the input clock for each by dividing the source clock signal from the OSC1 or OSC3 oscillation circuit.

The source clock and the dividing ratio of the prescaler can be selected individually for timer 0 and timer 1 in software.

The input clocks are set by the below sequence.

#### (1) Selection of source clock

Select the source clock (OSC1 or OSC3) for each prescaler. This is done with the source clock selection registers CKSEL0 (timer 0) and CKSEL1 (timer 1): when "0" is written, OSC1 is selected and when "1" is written, OSC3 is selected. When the 16-bit mode is selected, the source clock is selected by register CKSEL0, and the register CKSEL1 setting becomes invalid. When the OSC3 oscillation circuit is made the clock source, it is necessary to turn the OSC3 oscillation ON, prior to using the programmable timer.

From the time the OSC3 oscillation circuit is turning ON until oscillation stabilizes, an interval of several msec to several 10 msec is necessary. Consequently, you should allow an adequate waiting time after turning the OSC3 oscillation circuit ON before starting the count of the programmable timer. (The oscillation start time will vary somewhat depending on the oscillator and on external parts. Refer to the oscillation start time example indicated in Chapter 7, "ELECTRICAL CHARACTERISTICS".)

At initial reset, OSC3 oscillation circuit is set to OFF status.

#### (2) Selection of prescaler dividing ratio

Select the dividing ratio of each prescaler from among 4 types. This selection is done by the prescaler dividing ratio selection registers PSC00/PSC01 (timer 0) and PSC10/PSC11 (timer 1). Setting value and dividing ratio correspondence are shown in Table 5.11.3.1.

Table 5.11.3.1 Selection of prescaler dividing ratio

PSC11 PSC01	PSC10 PSC00	Prescaler dividing ratio
1	1	Source clock / 64
1	0	Source clock / 16
0	1	Source clock / 4
0	0	Source clock / 1

By writing "1" to the register PRUN0 (timer 0) and PRUN1 (timer 1), the source clock is input to the prescaler. Therefore, the clock with selected dividing ratio is input to the timer and the timer starts counting down.

When the 16-bit mode has been selected, the dividing ratio for the source clock is selected by register PSC00/PSC01 and the setting of register PSC10/PSC11 becomes invalid.

### 5.11.4 Timer mode

The timer mode counts down using the prescaler output as an input clock. In this mode, the programmable timer operates as a timer that obtains fixed cycles using the OSC1 or OSC3 oscillation circuit as a clock source.

See "5.11.2 Count operation and basic mode setting" for basic operation and control, and "5.11.3 Setting input clock" for the clock source and setting of the prescaler.

### 5.11.5 Event counter mode

Timer 0 includes an even counter function that counts by inputting an external clock (EVIN) to input port K10. This function is selected by writing "1" to the timer 0 counter mode selection register EVCNT.

When the event counter mode is selected, timer 0 operates as an event counter and timer 1 operates as a normal timer in 8-bit mode. In the 16-bit mode, timer 0 and timer 1 operate as 1 channel 16-bit event counter. In the event counter mode, since the timer 0 is clocked externally, the settings of registers PSC00/PSC01 become invalid.

Count down timing can be controlled by either the falling edge or rising edge selected by the timer 0 pulse polarity selection register PLPOL. When "0" is written to the register PLPOL, the falling edge is selected, and when "1" is written, the rising edge is selected. The timing is shown in Figure 5.11.5.1.

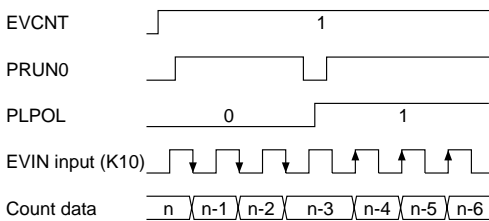

Fig. 5.11.5.1 Timing chart for event counter mode

The event counter also includes a noise rejecter to eliminate noise such as chattering for the external clock (EVIN). This function is selected by writing "1" to the timer 0 function selection register FCSEL.

For a reliable count when "with noise rejecter" is selected, you must allow 0.98 msec or more pulse width for both LOW and HIGH levels. (The noise rejecter allows clocking counter at the second falling edge of the internal 2,048 Hz signal after changing the input level of the K10 input port terminal. Consequently, the pulse width that can reliably be rejected is 0.48 msec.)

Figure 5.11.5.2 shows the count down timing with the noise rejecter selected.

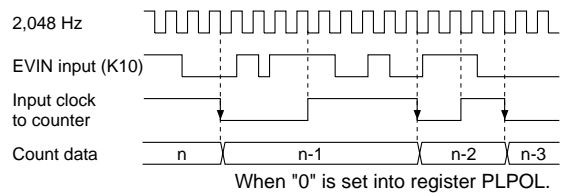

Fig. 5.11.5.2 Count down timing with noise rejecter

The event counter mode is the same as the timer mode except that the clock is external (EVIN). See "5.11.2 Count operation and setting basic mode" for the basic operation and control.

### 5.11.6 Pulse width measurement timer mode

Timer 0 includes a pulse width measurement function that measures the width of the input signal to the K10 input port terminal. This function is selected by writing "1" to the timer function selection register FCSEL when in the timer mode (EVCNT = "0").

When the pulse width measurement mode is selected, timer 0 operates as an pulse width measurement and timer 1 operates as a normal timer in 8-bit mode. In the 16-bit mode, timer 0 and timer 1 operate as 1 channel 16-bit pulse width measurement.

The level of the input signal (EVIN) for measurement can be changed either a LOW or HIGH level by the timer 0 pulse polarity selection register PLPOL. When "0" is written to register PLPOL, a LOW level width is measured and when "1" is written, a HIGH level width is measured. The timing is shown in Figure 5.11.6.1.

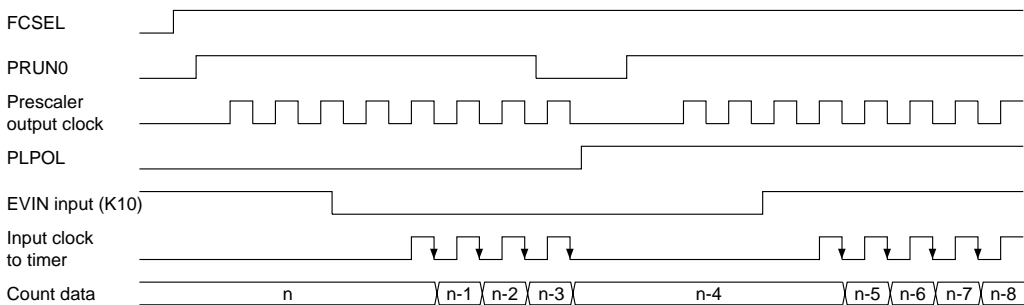

Fig. 5.11.6.1 Timing chart for pulse width measurement timer mode

The pulse width measurement timer mode is the same as the timer mode except that the input clock is controlled by the level of the signal (EVIN) input to the K10 input port terminal.  
See "5.11.2 Count operation and setting basic mode" for the basic operation and control.

### 5.11.7 Interrupt function

The programmable timer can generate an interrupt due to an underflow signal of timer 0 and timer 1. Figure 5.11.7.1 shows the configuration of the programmable timer interrupt circuit.

The respectively corresponding interrupt factor flags FPT0 and FPT1 are set to "1" and an interrupt is generated by an underflow signal of timers 1 and 0. Interrupt can also be prohibited by the setting of the interrupt enable registers EPT0 and EPT1 corresponding to each interrupt flag.

In addition, a priority level of the programmable timer interrupt for the CPU can be optionally set at levels 0 to 3 by the interrupt priority registers PPT0 and PPT1.

For details on the above mentioned interrupt control registers and the operation following generation of an interrupt, see "5.16 Interrupt and Standby Status".

The exception processing vector addresses of each interrupt factor are respectively set as shown below.

Programmable timer 1 interrupt: 000006H  
 Programmable timer 0 interrupt: 000008H

When the 16-bit mode is selected, the interrupt factor flag FPT0 is not set to "1" and a timer 0 interrupt cannot be generated. (In the 16-bit mode, the interrupt factor flag FPT1 is set to "1" by an underflow of the 16-bit counter.)

### 5.11.8 Setting of TOUT output

The programmable timer can generate a TOUT signal due to an underflow of timer 0 or timer 1. A TOUT signal is the above mentioned underflow divided by 1/2. The timer underflow which is to be used can be selected by the TOUT output channel selection register CHSEL. When writing "0" to register CHSEL, timer 0 is selected and when "1" is written, timer 1 is selected. However, in the 16-bit mode, it is fixed in timer 1 (underflow of the 16-bit timer) and the setting of register CHSEL becomes invalid.

Figure 5.11.8.1 shows the TOUT signal waveform when channel switching.

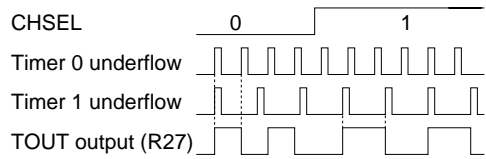

Fig. 5.11.8.1 TOUT signal waveform at channel change

The TOUT signal can be output from the R27 output port terminal and the programmable clock can be supplied to an external device.

The configuration of the output port R27 is shown in Figure 5.11.8.2.

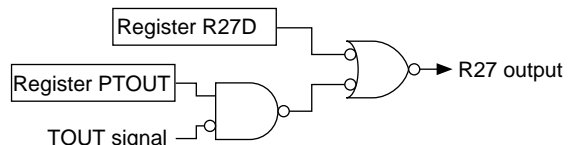

Fig. 5.11.8.2 Configuration of R27

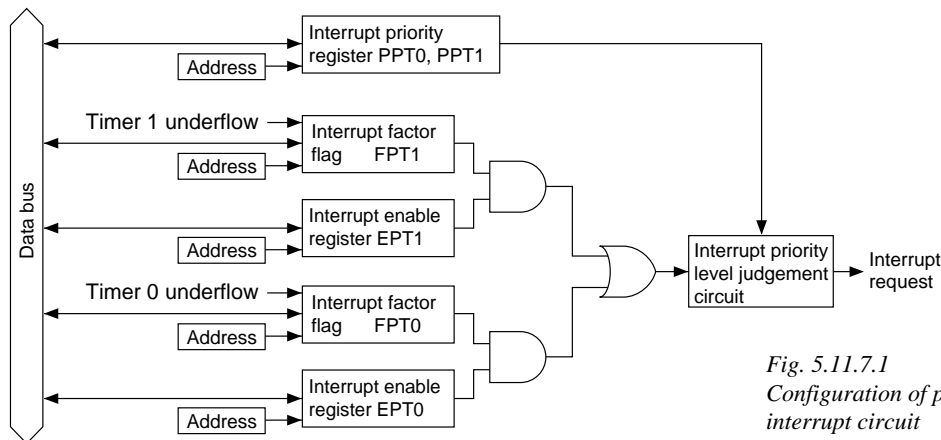

Fig. 5.11.7.1 Configuration of programmable timer interrupt circuit

The output control of the TOUT signal is done by register PTOUT. When "1" is set to the PTOUT, the TOUT signal is output from the R27 output port and when "0" is set, HIGH (VDD) level is output. At this time, "1" must always be set in the data register R27D.

Since the TOUT signal is generated asynchronously from the register PTOUT, when the signal is turned ON or OFF by the register setting, a hazard of a 1/2 cycle or less is generated.

Figure 5.11.8.3 shows the output waveform of TOUT signal.

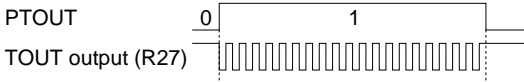

Fig. 5.11.8.3 Output waveform of the TOUT signal

### 5.11.9 Transmission rate setting of serial interface

The underflow signal of the timer 1 can be used to clock the serial interface.

The transmission rate setting in this case is made in registers PSC1X and PLD1X, and is used to set the count mode to the reload count mode (RLMD1 = "1").

Since the underflow signal of the timer 1 is divided by 1/32 in the serial interface, the value set in register RLD1X which corresponds to the transmission rate is shown in the following expression:

$$RLD1X = fosc / (32 * bps * 4^{PSC1X}) - 1$$

fosc: Oscillation frequency (OSC1/OSC3)

bps: Transmission rate

PSC1X: Setting value to the register PSC1X (0-3)

(00H can be set to RLD1X)

Table 5.11.9.1 shows an example of the transmission rate setting when the OSC3 oscillation circuit is used as a clock source.

Table 5.11.9.1 Example of transmission rate setting

Transfer rate (bps)	OSC3 oscillation frequency / Programmable timer settings					
	fosc3 = 3.072 MHz		fosc3 = 4.608 MHz		fosc3 = 4.9152 MHz	
	PSC1X	RLD1X	PSC1X	RLD1X	PSC1X	RLD1X
9,600	0 (1/1)	09H	0 (1/1)	0EH	0 (1/1)	0FH
4,800	0 (1/1)	13H	0 (1/1)	1DH	0 (1/1)	1FH
2,400	0 (1/1)	27H	0 (1/1)	3BH	0 (1/1)	3FH
1,200	0 (1/1)	4FH	0 (1/1)	77H	0 (1/1)	7FH
600	0 (1/1)	9FH	0 (1/1)	EFH	0 (1/1)	FFH
300	1 (1/4)	4FH	1 (1/4)	77H	1 (1/4)	7FH
150	1 (1/4)	9FH	1 (1/4)	EFH	1 (1/4)	FFH

## 5.11.10 Control of programmable timer

Table 5.11.10.1 shows the programmable timer control bits.

Table 5.11.10.1(a) Programmable timer control bits

Address	Bit	Name	Function	1	0	SR	R/W	Comment		
00FF30	D7	—	—	—	—	—		Constrant "0" when being read		
	D6	—	—	—	—	—				
	D5	—	—	—	—	—				
	D4	MODE16	8/16-bit mode selection		16-bit x 1	8-bit x 2	0	R/W		
	D3	CHSEL	TOUT output channel selection		Timer 1	Timer 0	0	R/W		
	D2	PTOUT	TOUT output control		On	Off	0	R/W		
	D1	CKSEL1	Prescaler 1 source clock selection		fosc3	fosc1	0	R/W		
	D0	CKSEL0	Prescaler 0 source clock selection		fosc3	fosc1	0	R/W		
00FF31	D7	EVCNT	Timer 0 counter mode selection		Event counter	Timer	0	R/W		
	D6	FCSEL	Timer 0 function selection	In timer mode	Pulse width measurement	Normal mode	0	R/W		
				In event counter mode	With noise rejector	Without noise rejector				
	D5	PLPOL	Timer 0 pulse polarity selection	Down count timing in event counter mode	Rising edge of K10 input	Falling edge of K10 input	0	R/W		
				In pulse width measurement mode	High level measurement for K10 input	Low level measurement for K10 input				
	D4	PSC01	Timer 0 prescaler dividing ratio selection					0	R/W	
			PSC01	PSC00	Prescaler dividing ratio					
	D3	PSC00	1	1	Source clock / 64			0	R/W	
			1	0	Source clock / 16					
			0	1	Source clock / 4					
0			0	Source clock / 1						
D2	CONT0	Timer 0 continuous/one-shot mode selection		Continuous	One-shot	0	R/W			
D1	PSET0	Timer 0 preset		Preset	No operation	—	W	"0" when being read		
D0	PRUN0	Timer 0 Run/Stop control		Run	Stop	0	R/W			
00FF32	D7	—	—	—	—	—		Constrant "0" when being read		
	D6	—	—	—	—	—				
	D5	—	—	—	—	—				
	D4	PSC11	Timer 1 prescaler dividing ratio selection					0	R/W	
			PSC11	PSC10	Prescaler dividing ratio					
	D3	PSC10	1	1	Source clock / 64			0	R/W	
			1	0	Source clock / 16					
			0	1	Source clock / 4					
0			0	Source clock / 1						
D2	CONT1	Timer 1 continuous/one-shot mode selection		Continuous	One-shot	0	R/W			
D1	PSET1	Timer 1 preset		Preset	No operation	—	W	"0" when being read		
D0	PRUN1	Timer 1 Run/Stop control		Run	Stop	0	R/W			

## 5 PERIPHERAL CIRCUITS AND THEIR OPERATION (Programmable Timer)

Table 5.11.10.1(b) Programmable timer control bits

Address	Bit	Name	Function	1	0	SR	R/W	Comment
00FF33	D7	RLD07	Timer 0 reload data D7 (MSB)	High	Low	1	R/W	
	D6	RLD06	Timer 0 reload data D6					
	D5	RLD05	Timer 0 reload data D5					
	D4	RLD04	Timer 0 reload data D4					
	D3	RLD03	Timer 0 reload data D3					
	D2	RLD02	Timer 0 reload data D2					
	D1	RLD01	Timer 0 reload data D1					
	D0	RLD00	Timer 0 reload data D0 (LSB)					
00FF34	D7	RLD17	Timer 1 reload data D7 (MSB)	High	Low	1	R/W	
	D6	RLD16	Timer 1 reload data D6					
	D5	RLD15	Timer 1 reload data D5					
	D4	RLD14	Timer 1 reload data D4					
	D3	RLD13	Timer 1 reload data D3					
	D2	RLD12	Timer 1 reload data D2					
	D1	RLD11	Timer 1 reload data D1					
	D0	RLD10	Timer 1 reload data D0 (LSB)					
00FF35	D7	PTD07	Timer 0 counter data D7 (MSB)	High	Low	1	R	
	D6	PTD06	Timer 0 counter data D6					
	D5	PTD05	Timer 0 counter data D5					
	D4	PTD04	Timer 0 counter data D4					
	D3	PTD03	Timer 0 counter data D3					
	D2	PTD02	Timer 0 counter data D2					
	D1	PTD01	Timer 0 counter data D1					
	D0	PTD00	Timer 0 counter data D0 (LSB)					
00FF36	D7	PTD17	Timer 1 counter data D7 (MSB)	High	Low	1	R	
	D6	PTD16	Timer 1 counter data D6					
	D5	PTD15	Timer 1 counter data D5					
	D4	PTD14	Timer 1 counter data D4					
	D3	PTD13	Timer 1 counter data D3					
	D2	PTD12	Timer 1 counter data D2					
	D1	PTD11	Timer 1 counter data D1					
	D0	PTD10	Timer 1 counter data D0 (LSB)					

Table 5.11.10.1(c) Programmable timer control bits

Address	Bit	Name	Function	1	0	SR	R/W	Comment	
00FF21	D7	—	—	—	—	—	—	Constantly "0" when being read	
	D6	—	—	—	—	—	—		
	D5	—	—	—	—	—	—		
	D4	—	—	—	—	—	—		
	D3	PPT1	Programmable timer interrupt priority register	PPT1	PPT0	Priority level	0	R/W	
	D2	PPT0		PK11	PK10				
D1	PK11	K10 and K11 interrupt priority register	1	1	Level 2	0	R/W		
D0	PK10		0	1	Level 1				
			0	0	Level 0				
00FF23	D7	EPT1	Programmable timer 1 interrupt enable register	Interrupt enable	Interrupt disable	0	R/W		
	D6	EPT0	Programmable timer 0 interrupt enable register						
	D5	EK1	K10 and K11 interrupt enable register						
	D4	EK0H	K04–K07 interrupt enable register						
	D3	EK0L	K00–K03 interrupt enable register						
	D2	ESERR	Serial I/F (error) interrupt enable register						
	D1	ESREC	Serial I/F (receiving) interrupt enable register						
D0	ESTRA	Serial I/F (transmitting) interrupt enable register							
00FF25	D7	FPT1	Programmable timer 1 interrupt factor flag	(R)	(R)	0	R/W		
	D6	FPT0	Programmable timer 0 interrupt factor flag	Interrupt factor is generated	No interrupt factor is generated				
	D5	FK1	K10 and K11 interrupt factor flag						
	D4	FK0H	K04–K07 interrupt factor flag						
	D3	FK0L	K00–K03 interrupt factor flag						
	D2	FSERR	Serial I/F (error) interrupt factor flag	(W)	(W)				
	D1	FSREC	Serial I/F (receiving) interrupt factor flag	Reset	No operation				
D0	FSTRA	Serial I/F (transmitting) interrupt factor flag							

**MODE16: 00FF30H•D4**

Selects the 8/16-bit mode.

When "1" is written: 16 bits × 1 channel

When "0" is written: 8 bits × 2 channels

Reading: Valid

Select whether timer 0 and timer 1 will be used as 2 channel independent 8-bit timers or as a 1 channel combined 16-bit timer. When "0" is written to MODE16, 8-bit × 2 channels is selected and when "1" is written, 16-bit × 1 channel is selected. At initial reset, MODE16 is set to "0" (8-bit × 2 channels).

**CKSEL0, CKSEL1: 00FF30H•D0, D1**

Select the source clock of the prescaler.

When "1" is written: OSC3 clock

When "0" is written: OSC1 clock

Reading: Valid

Select whether the source clock of prescaler 0 will be set to OSC1 or OSC3. When "0" is written to CKSEL0, OSC1 is selected and when "1" is written, OSC3 is selected.

In the same way, the source clock of prescaler 1 is selected by CKSEL1.

When event counter mode has been selected, the setting of the CKSEL0 becomes invalid. In the same way, the CKSEL1 setting becomes invalid when 16-bit mode has been selected.

At initial reset, this register is set to "0" (OSC1 clock).

**PSC00, PSC01: 00FF31H•D3, D4**  
**PSC10, PSC11: 00FF32H•D3, D4**

Select the dividing ratio of the prescaler. Two-bit PSC00 and PSC01 is the prescaler dividing ratio selection registers for timer 0, and the two-bit PSC10 and PSC11 correspond to timer 1. The prescaler dividing ratios that can be set by these registers are shown in Table 5.11.10.2.

Table 5.11.10.2 Selection of prescaler dividing ratio

PSC11 PSC01	PSC10 PSC00	Prescaler dividing ratio
1	1	Input clock / 64
1	0	Input clock / 16
0	1	Input clock / 4
0	0	Input clock / 1

When event counter mode has been selected, the setting of the PSC00 and PSC01 becomes invalid. In the same way, the PSC10 and PSC11 setting becomes invalid when 16-bit mode has been selected. At initial reset, this register is set to "0" (input clock/1).

**EVCNT: 00FF31H•D7**

Selects the counter mode for the timer 0.

- When "1" is written: Event counter mode
- When "0" is written: Timer mode
- Reading: Valid

Select whether timer 0 will be used as an event counter or a timer. When "1" is written to EVCNT, the event counter mode is selected and when "0" is written, the timer mode is selected. At initial reset, EVCNT is set to "0" (timer mode).

**FCSEL: 00FF31H•D6**

Selects the function for each counter mode of timer 0.

• In timer mode

- When "1" is written: Pulse width measurement timer mode
- When "0" is written: Normal mode
- Reading: Valid

In the timer mode, select whether timer 0 will be used as a pulse width measurement timer or a normal timer. When "1" is written to FCSEL, the pulse width measurement mode is selected and the counting is done according to the level of the signal (EVIN) input to the K10 input port terminal. When "0" is written to FCSEL, the normal mode is selected and the counting is not affected by the K10 input port terminal.

• In event counter mode

- When "1" is written: With noise rejecter
- When "0" is written: Without noise rejecter
- Reading: Valid

In the event counter mode, select whether the noise rejecter for the K10 input port terminal will be selected or not.

When "1" is written to FCSEL, the noise rejecter is selected and counting is done by an external clock (EVIN) with 0.98 msec or more pulse width. (The noise rejecter allows clocking counter at the second falling edge of the internal 2,048 Hz signal after changing the input level of the K10 input port terminal. Consequently, the pulse width that can reliably be rejected is 0.48 msec.)

When "0" is written to FCSEL, the noise rejecter is not selected and the counting is done directly by an external clock (EVIN) input to the K10 input port terminal.

At initial reset, FCSEL is set to "0".

**PLPOL: 00FF31H•D5**

Selects the pulse polarity for the K10 input port terminal.

• In event counter mode

- When "1" is written: Rising edge
- When "0" is written: Falling edge
- Reading: Valid

In the event counter mode, select whether the count timing will be set at the falling edge of the external clock (EVIN) input to the K10 input port terminal or at the rising edge. When "0" is written to PLPOL, the falling edge is selected and when "1" is written, the rising edge is selected.

• In pulse width measurement mode

- When "1" is written: High level pulse width measurement
- When "0" is written: LOW level pulse width measurement
- Reading: Valid

In the pulse width measurement mode, select whether the LOW level width of the signal (EVIN) input to the K10 input port terminal will be measured or the HIGH level will be measured. When "0" is written to PLPOL, the LOW level width measurement is selected and when "1" is written, the HIGH level width measurement is selected.

In the normal mode (EVCNT = FCSEL = "0"), the setting of PLPOL becomes invalid. At initial reset, PLPOL is set to "0".



***CONT0, CONT1: 00FF31H•D2, 00FF32H•D2***

Select the continuous/one-shot mode.

When "1" is written: Continuous mode

When "0" is written: One-shot mode

Reading: Valid

Select whether timer 0 will be used in the continuous mode or in the one-shot mode.

By writing "1" to CONT0, the programmable timer is set to the continuous mode. In the continuous mode, the initial counter value is automatically loaded when an underflow is generated, and counting is continued. On the other hand, when writing "0" to CONT0, the programmable timer is set to the one-shot mode. The counter loads an initial value and stops when an underflow is generated. At this time, PRUN0 is automatically reset to "0".

In the same way, the continuous/one-shot mode for timer 1 is selected by CONT1. (In the one-shot mode for timer 1, PRUN1 is automatically reset to "0" when the counter underflow is generated.)

At initial reset, this register is set to "0" (one-shot mode).

***RLD00–RLD07: 00FF33H******RLD10–RLD17: 00FF34H***

Sets the initial value for the counter.

RLD00–RLD07: Reload data for Timer 0

RLD10–RLD17: Reload data for Timer 1

The reload data set in this register is loaded into the respective counters and is counted down with that as the initial value.

Reload data is loaded to the counter under two conditions, when "1" is written to PSET0 or PSET1 and when the counter underflow automatically loads.

At initial reset, this register is set to "FFH".

***PTD00–PTD07: 00FF35H******PTD10–PTD17: 00FF36H***

Data of the programmable timer can be read out.

PTD00–PTD07: Timer 0 counter data

PTD10–PTD17: Timer 1 counter data

These bits act as a buffer to maintain the counter data during readout, and the data can be read as optional timing. However, in the 16-bit mode, to avoid a read error, (data error when a borrow from timer 0 to timer 1 is generated in the middle of reading PTD00–PTD07 and PTD10–PTD17), PTD10–PTD17 latches the timer 1 counter data according to the reading of PTD00–PTD07.

The latched status of PTD10–PTD17 is canceled according to the readout of PTD10–PTD17 or when 0.73–1.22 msec (depends on the readout timing) has elapsed. Therefore, in 16-bit mode, be sure to read the counter data of PTD00–PTD07 and PTD10–PTD17 in order.

Since these bits are exclusively for reading, the write operation is invalid.

At initial reset, these bits are set to "FFH".

***PSET0, PSET1: 00FF31H•D1, 00FF32H•D1***

Presets the reload data to the counter.

When "1" is written: Preset

When "0" is written: No operation

Reading: Always "0"

By writing "1" to PSET0, the reload data in PLD00–PLD07 is preset to the counter of timer 0. When the counter of timer 0 is preset in the RUN status, it restarts immediately after presetting.

In the case of STOP status, the reload data that has been preset is maintained.

No operation results when "0" is written.

In the same way, the reload data in PLD10–PLD17 is preset to the counter of timer 1 by PSET1.

When the 16-bit mode is selected, writing "1" to PSET1 is invalid.

This bit is exclusively for writing, it always becomes "0" during reading.

***PRUN0, PRUN1: 00FF31H•D0, 00FF32H•D0***

Controls the RUN/STOP of the counter.

When "1" is written: RUN

When "0" is written: STOP

Reading: Valid

The counter of timer 0 starts down-counting by writing "1" to PRUN0 and stops by writing "0".

In the STOP status, the counter data is maintained until it is preset or set in the next RUN status. Also, when the STOP status changes to the RUN status, the data that was maintained can be used for resuming the count.

In the same way, the RUN/STOP of the timer 1 counter is controlled by PRUN1.

When the 16-bit mode is selected, PRUN1 is fixed at "0".

At initial reset and when an underflow is generated in the one-shot mode, this register is set to "0" (STOP).

**CHSEL: 00FF30H•D3**

Selects the channel of the TOUT signal.

- When "1" is written: Timer 0 underflow
- When "0" is written: Timer 1 underflow
- Reading: Valid

Select whether the timer 0 underflow will be used for the TOUT signal or the timer 1 underflow will be used. When "0" is written to CHSEL, timer 0 is selected and when "1" is written, timer 1 is selected. When the 16-bit mode has been selected, it is fixed to timer 1 (underflow of the 16-bit timer), and setting of CHSEL becomes invalid.

At initial reset, CHSEL is set to "0" (timer 1 underflow).

**PTOUT: 00FF30H•D2**

Controls the TOUT signal output.

- When "1" is written: TOUT signal output
- When "0" is written: HIGH level (DC) output
- Reading: Valid

PTOUT is the output control register for TOUT signal. When "1" is set, the TOUT signal is output from the output port terminal R27 and when "0" is set, HIGH (VDD) level is output. At this time, "1" must always be set for the data register R27D.

At initial reset, PTOUT is set to "0" (HIGH level output).

**PPT0, PPT1: 00FF21H•D2, D3**

Sets the priority level of the programmable timer interrupt.

The two bits PPT0 and PPT1 are the interrupt priority register corresponding to the programmable timer interrupt. Table 5.11.10.3 shows the interrupt priority level which can be set by this register.

*Table 5.11.10.3 Interrupt priority level settings*

PPT1	PPT0	Interrupt priority level
1	1	Level 3 ( $\overline{\text{IRQ}}_3$ )
1	0	Level 2 ( $\overline{\text{IRQ}}_2$ )
0	1	Level 1 ( $\overline{\text{IRQ}}_1$ )
0	0	Level 0 (None)

At initial reset, this register is set to "0" (level 0).

**EPT0, EPT1: 00FF23H•D6, D7**

Enables or disables the generation of an interrupt for the CPU.

- When "1" is written: Interrupt enabled
- When "0" is written: Interrupt disabled
- Reading: Valid

The EPT0 and EPT1 are interrupt enable registers that respectively correspond to the interrupt factors for timer 0 and timer 1. Interrupts set to "1" are enabled and interrupts set to "0" are disabled. When the 16-bit mode is selected, setting of EPT0 becomes invalid.

At initial reset, this register is set to "0" (interrupt disabled).

**FPT0, FPT1: 00FF25H•D6, D7**

Indicates the programmable timer interrupt generation status.

- When "1" is read: Interrupt factor present
- When "0" is read: Interrupt factor not present
- When "1" is written: Resets factor flag
- When "0" is written: Invalid

The FPT0 and FPT1 are interrupt factor flags that respectively correspond to the interrupts for timer 0 and timer 1 and are set to "1" in synchronization with the underflow of each counter.

When set in this manner, if the corresponding interrupt enable register is set to "1" and the corresponding interrupt priority register is set to a higher level than the setting of interrupt flags (I0 and I1), an interrupt will be generated to the CPU. Regardless of the interrupt enable register and interrupt priority register settings, the interrupt factor flag will be set to "1" by the occurrence of an interrupt generation condition.

To accept the subsequent interrupt after interrupt generation, re-setting of the interrupt flags (set interrupt flag to lower level than the level indicated by the interrupt priority registers, or execute the RETE instruction) and interrupt factor flag reset are necessary. The interrupt factor flag is reset to "0" by writing "1".

When the 16-bit mode is selected, the interrupt factor flag FPT0 is not set to "1" and a timer 0 interrupt cannot be generated. (In the 16-bit mode, the interrupt factor flag FPT1 is set to "1" by an underflow of the 16-bit counter.)

At initial reset, this flag is reset to "0".

### 5.11.11 Programming notes

- (1) The programmable timer is actually made to RUN/STOP in synchronization with the falling edge of the input clock after writing to the PRUN0(1) register. Consequently, when "0" is written to the PRUN0(1), the timer shifts to STOP status when the counter is decremented "1". The PRUN0(1) maintains "1" for reading until the timer actually shifts to STOP status. Figure 5.11.11.1 shows the timing chart of the RUN/STOP control.

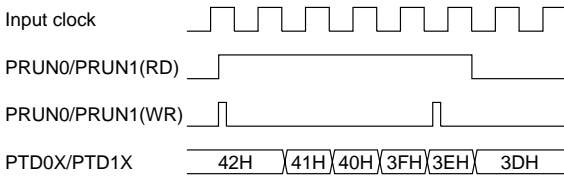

Fig. 5.11.11.1 Timing chart of RUN/STOP control

The event counter mode is excluded from the above note.

- (2) The SLP instruction is executed when the programmable timer is in the RUN status (PRUN0(1) = "1"). The programmable timer operation will become unstable when returning from SLEEP status. Therefore, when shifting to SLEEP status, set the clock timer to STOP status (PRUN0(1) = "0") prior to executing the SLP instruction. In the same way, disable the TOUT signal (PTOUT = "0") to avoid an unstable clock output to the R27 output port terminal.
- (3) Since the TOUT signal is generated asynchronously from the register PTOUT, when the signal is turned ON or OFF by the register setting, a hazard of a 1/2 cycle or less is generated.
- (4) When the OSC3 oscillation circuit is made the clock source, it is necessary to turn the OSC3 oscillation ON, prior to using the programmable timer. From the time the OSC3 oscillation circuit is turning ON until oscillation stabilizes, an interval of several msec to several 10 msec is necessary. Consequently, you should allow an adequate waiting time after turning the OSC3 oscillation circuit ON before starting the count of the programmable timer. (The oscillation start time will vary somewhat depending on the oscillator and on external parts. Refer to the oscillation start time example indicated in Chapter 7, "ELECTRICAL CHARACTERISTICS".) At initial reset, OSC3 oscillation circuit is set to OFF status.
- (5) When the 16-bit mode has been selected, be sure to read the counter data in the order of PTD00–PTD07 and PTD10–PTD17. Moreover, the time interval between reading PTD00–PTD07 and PTD10–PTD17 should be 0.73 msec or less.

## 5.12 LCD Controller

### 5.12.1 Configuration of LCD controller

The E0C88xx has a built-in dot matrix LCD driver. The E0C88348/317/316 allows an LCD panel with a maximum of 1,632 dots (51 segments × 32 commons). In the E0C88308 a maximum of 1,312 dots (41 segments × 32 commons) are permitted. It also has an LCD controller for an external LCD driver. Figure 5.12.1.1 shows the configuration of the LCD controller and the drive power supply.

### 5.12.2 Mask option

Selection of the drive duty for the built-in LCD driver can be selected whether it will be 1/32 and 1/16 software-switched or fixed at 1/8 by the mask option.

LCD drive duty	
<input type="checkbox"/>	1/32 & 1/16 duty
<input type="checkbox"/>	1/8 duty

When "1/32 & 1/16 duty" is selected, the drive duty can be selected by software. When "0" is written to the drive duty selection register LDUTY, 1/32 duty is selected and when "1" is written, 1/16 duty is selected.

When "1/8 duty" is selected, the drive duty is fixed at 1/8 and setting of LDUTY becomes invalid. When the built-in LCD driver is not used, select the default setting of "1/32 & 1/16 duty".

### 5.12.3 LCD power supply

For the LCD system drive voltages  $V_{C1}$ – $V_{C5}$ , either the internal power supply or external power supply can be selected by the mask option.

When the internal power supply is selected, voltage is generated by the internal voltage regulator and voltage booster circuits. The internal power supply can generate two types of reference voltage; TYPE A (4.5 V) and TYPE B (5.5 V), and either one can be selected by the mask option.

When external power supply is selected, the voltage should be supplied from outside of the IC.

LCD power supply	
<input type="checkbox"/>	Internal power supply TYPE A (4.5 V)
<input type="checkbox"/>	Internal power supply TYPE B (5.5 V)
<input type="checkbox"/>	External power supply

The internal power supply is designed for a small scale LCD panel and is not suitable for driving a panel that has large size pixels or for driving a large capacity panel using an external expanded LCD driver. In this case, select external power supply and input the regulated voltage from outside of the IC.

Figure 5.12.3.1 shows the circuit examples when using an external power supply.

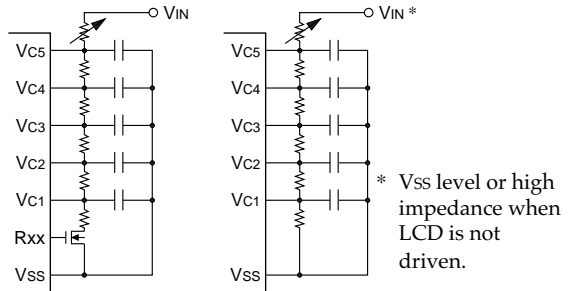
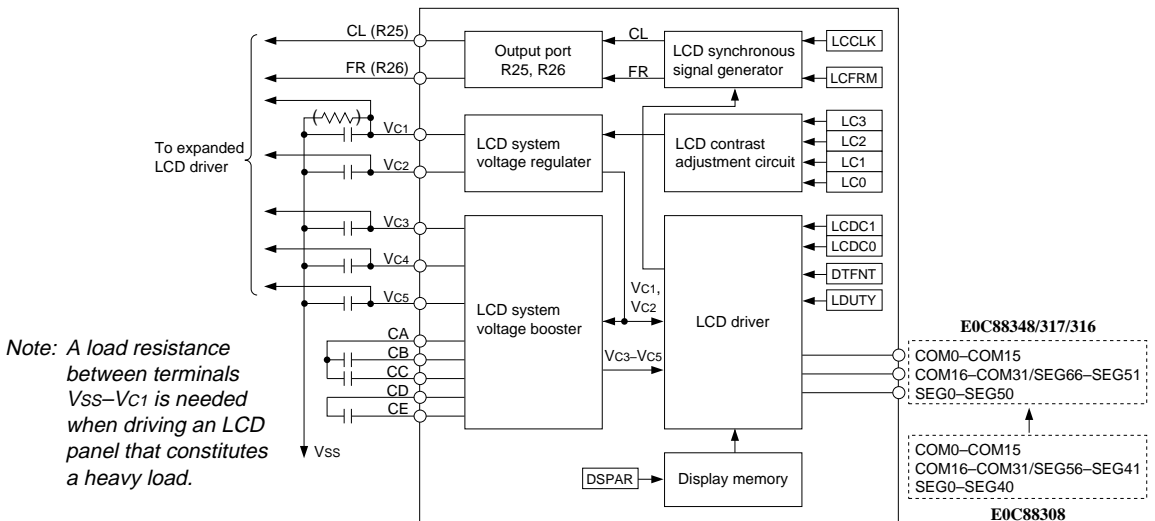

Fig. 5.12.3.1  
Circuit examples when using an external power supply



Note: A load resistance between terminals  $V_{SS}$ – $V_{C1}$  is needed when driving an LCD panel that constitutes a heavy load.

Fig. 5.12.1.1 Configuration of LCD controller and drive power supply

### 5.12.4 LCD driver

The maximum number of dots changes according to the drive duty selection.

When 1/32 duty is selected, the combined common/segment output terminal is switched to the common terminal. An LCD panel with 51 segments  $\times$  32 commons (maximum 1,632 dots) in the E0C88348/317/316 and 41 segments  $\times$  32 commons (maximum 1,312 dots) in the E0C88308 can be driven.

When 1/16 duty is selected, the combined common/segment output terminal is switched to the segment terminal. An LCD panel with 67 segments  $\times$  16 commons (maximum 1,072 dots) in the E0C88348/317/316 and 57 segments  $\times$  16 commons (maximum 912 dots) in the E0C88308 can be driven.

When 1/8 duty is selected, the combined common/segment output terminal is switched to the segment terminal as when 1/16 duty is selected. An LCD panel with 67 segments  $\times$  8 commons (maximum 536 dots) in the E0C88348/317/316 and 57 segments  $\times$  8 commons (maximum 456 dots) in the E0C88308 can be driven. Furthermore, when 1/8 duty is selected, terminals COM8–COM15 become invalid, in that they always output an OFF signal. Table 5.12.4.1 shows the correspondence between the drive duty and the maximum number of displaying dots.

The drive bias is 1/5 (five potentials, VC1–VC5) for any one of the 1/32, 1/16 and 1/8 duties. The respective drive waveforms are shown in Figures 5.12.4.1–5.12.4.3.

Table 5.12.4.1 Correspondence between drive duty and maximum number of displaying dots

Model name	Mask option	LDUTY	Duty	Common terminal	Segment terminal	Maximum number of display dots
<b>E0C88348</b>	1/32 & 1/16 duty	0	1/32	COM0–COM31	SEG0–SEG50	1,632 dots
<b>E0C88317</b>		1	1/16	COM0–COM15	SEG0–SEG66	1,072 dots
<b>E0C88316</b>	1/8 duty	×	1/8	COM0–COM7	SEG0–SEG66	536 dots
<b>E0C88308</b>	1/32 & 1/16 duty	0	1/32	COM0–COM31	SEG0–SEG40	1,312 dots
		1	1/16	COM0–COM15	SEG0–SEG56	912 dots
	1/8 duty	×	1/8	COM0–COM7	SEG0–SEG56	456 dots

## 5 PERIPHERAL CIRCUITS AND THEIR OPERATION (LCD Controller)

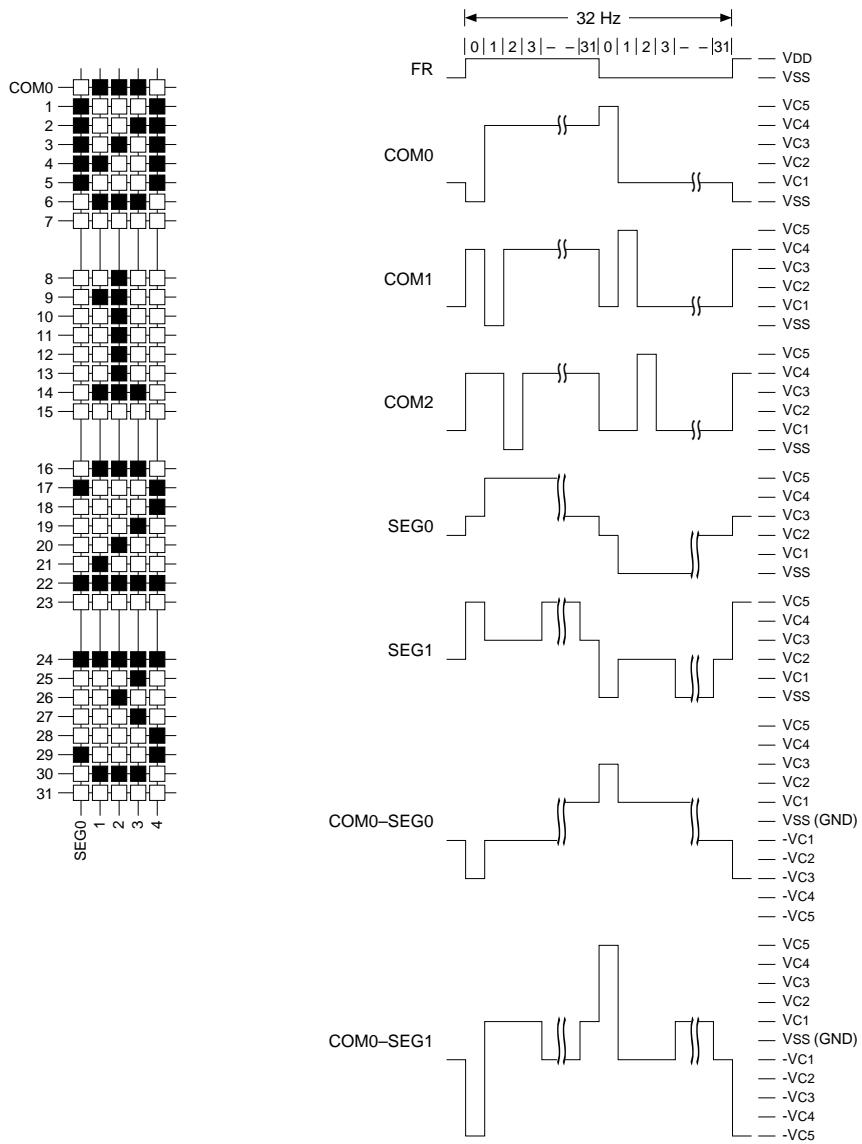

Fig. 5.12.4.1 Drive waveform for 1/32 duty

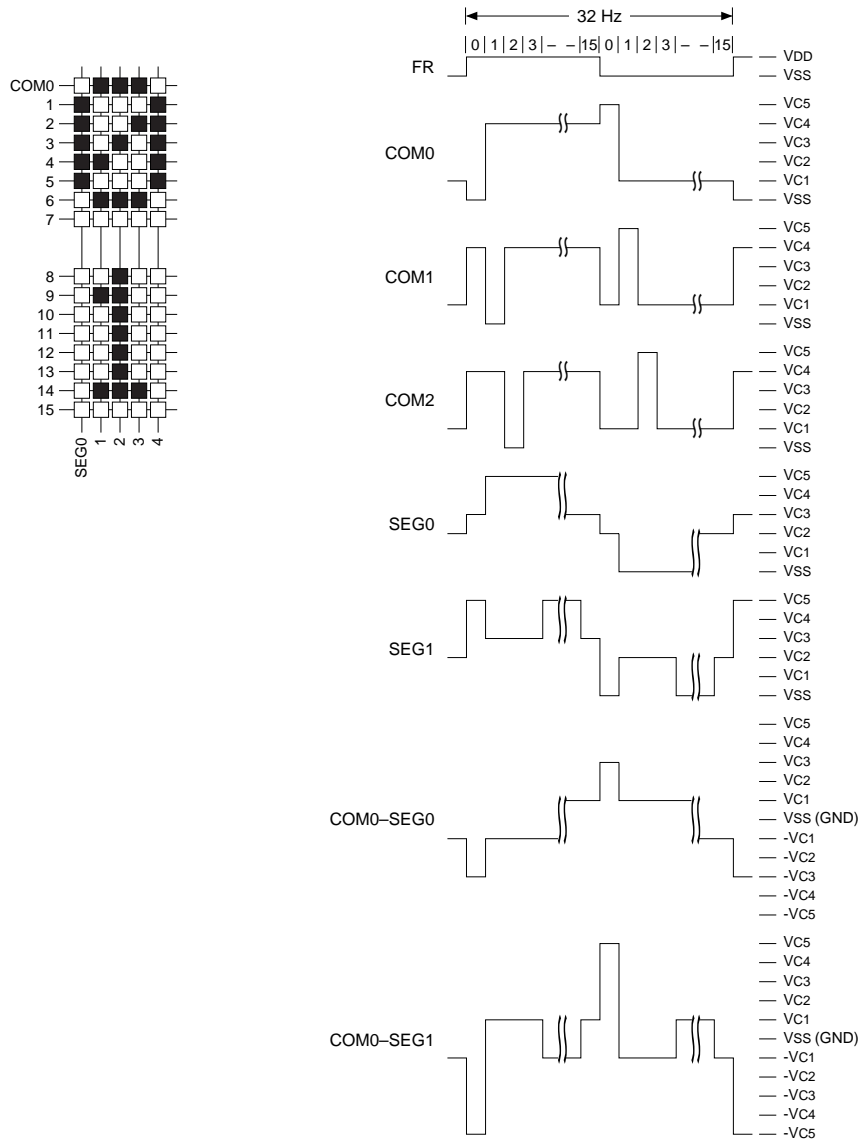

Fig. 5.12.4.2 Drive waveform for 1/16 duty

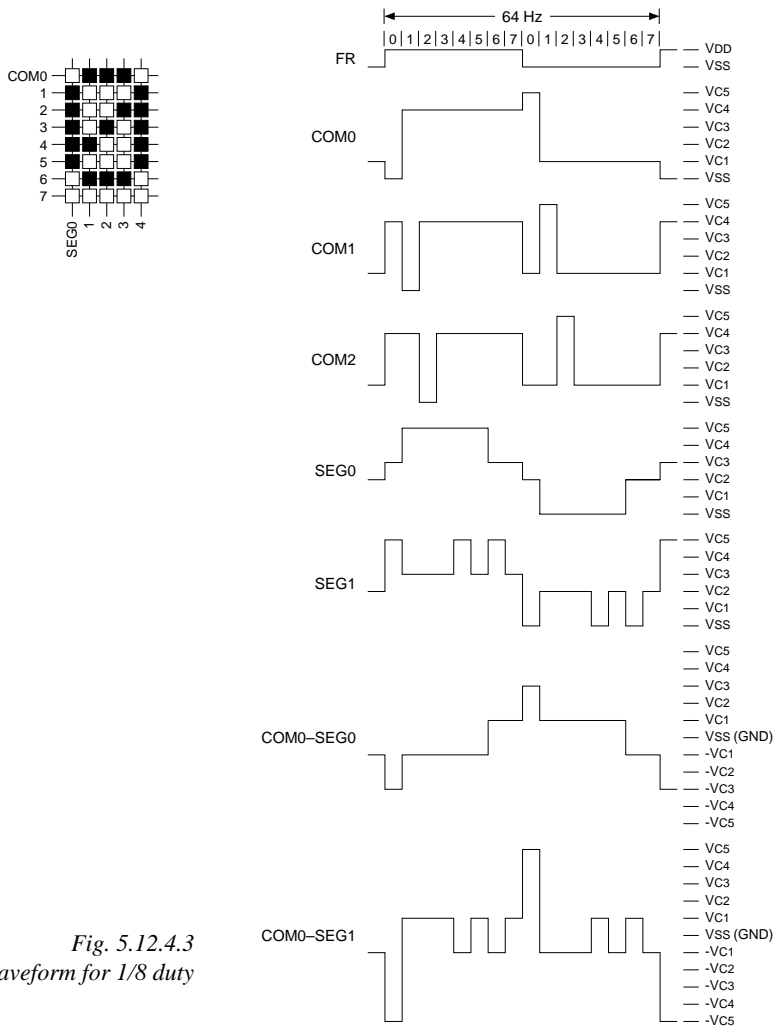

Fig. 5.12.4.3  
Drive waveform for 1/8 duty

**5.12.5 Display memory**

The E0C883xx has a built-in 402-byte display memory. The display memory is allocated to address Fx00H-Fx42H (x = 8-DH) and the correspondence between the memory bits and common/segment terminal is changed according to the selection status of the following items.

- (1) Drive duty (1/32, 1/16 or 1/8 duty)
- (2) Dot font (5 × 8 or 5 × 5 dots)

When 1/16 or 1/8 duty is selected for drive duty, two-screen memory can be secured, and the two screens can be switched by the display memory area selection register DSPAR. When "0" is written to DSPAR, display area 0 is selected and when "1" is written, display area 1 is selected.

Furthermore, memory allocation for 5 × 8 dots and 5 × 5 dots can be selected in order to easily display 5 × 5-dot font characters on the LCD panel. This selection can be done by the dot font selection register DTFNT: when "0" is written to DTFNT, 5 × 8 dots is selected and when "1" is written, 5 × 5 dots is selected.

The correspondence between the display memory bits set according to the drive duty and font size, and the common/segment terminals are shown in Figures 5.12.5.1-5.12.5.6.

When "1" is written to the display memory bit corresponding to the dot on the LCD panel, the dot goes ON and when "0" is written, it goes OFF. Since display memory is designed to permit reading/writing, it can be controlled in bit units by logical operation instructions and other means (read, modify and write instructions).

The display area bits which have not been assigned within the 402-byte display memory can be used as general purpose RAM with read/write capabilities. Even when external memory has expanded into the display memory area, this area is not released to external memory. Access to this area is always via display memory.







Address/Data bit	0								1								2								3								4								COM																										
	0	1	2	3	4	5	6	7	8	9	10	11	12	13	14	15	16	17	18	19	20	21	22	23	24	25	26	27	28	29	30	31	32	33	34	35	36	37	38	39		40	41	42	43	44	45	46	47	48	49	50	51	52	53	54	55	56	57	58	59	60	61	62	63	64	65
D0																																																																			
D1																																																																			
D2																																																																			
D3																																																																			
D4																																																																			
D5																																																																			
D6																																																																			
D7																																																																			
D0																																																																			
D1																																																																			
D2																																																																			
D3																																																																			
D4																																																																			
D5																																																																			
D6																																																																			
D7																																																																			
D0																																																																			
D1																																																																			
D2																																																																			
D3																																																																			
D4																																																																			
D5																																																																			
D6																																																																			
D7																																																																			
D0																																																																			
D1																																																																			
D2																																																																			
D3																																																																			
D4																																																																			
D5																																																																			
D6																																																																			
D7																																																																			
D0																																																																			
D1																																																																			
D2																																																																			
D3																																																																			
D4																																																																			
D5																																																																			
D6																																																																			
D7																																																																			
D0																																																																			
D1																																																																			
D2																																																																			
D3																																																																			
D4																																																																			
D5																																																																			
D6																																																																			
D7																																																																			

Fig. 5.12.5.3 1/16 duty and 5 × 8 dots display memory map

\* In the E0C88308, an area of 00F<sub>x</sub>39H–00F<sub>x</sub>42H (x = 8–BH) is secured as general purpose RAM with read/write capabilities that does not affect the display.

## 5 PERIPHERAL CIRCUITS AND THEIR OPERATION (LCD Controller)

Address/Data bit	0																1																2																3																4				COM										
	0	1	2	3	4	5	6	7	8	9	A	B	C	D	E	F	0	1	2	3	4	5	6	7	8	9	A	B	C	D	E	F	0	1	2	3	4	5	6	7	8	9	A	B	C	D	E	F	0	1	2	3	4	5	6	7	8	9	A	B	C	D	E	F	0	1	2	3		4	5	6	7	8	9	A	B	C	D
D0	Display area 0 (when "0" is set into DSPAR)																Display area 0 (when "0" is set into DSPAR)																Display area 0 (when "0" is set into DSPAR)																Display area 0 (when "0" is set into DSPAR)																*				0										
D1																																																																					1										
D2																																																																					2										
D3																																																																					3										
D4																																																																					4										
D5	Display area 0 (when "0" is set into DSPAR)																Display area 0 (when "0" is set into DSPAR)																Display area 0 (when "0" is set into DSPAR)																Display area 0 (when "0" is set into DSPAR)																*				5										
D6																																																																					6										
D7																																																																					7										
D8																																																																					8										
D9																																																																					9										
D10	Display area 0 (when "0" is set into DSPAR)																Display area 0 (when "0" is set into DSPAR)																Display area 0 (when "0" is set into DSPAR)																Display area 0 (when "0" is set into DSPAR)																*				10										
D11																																																																					11										
D12																																																																					12										
D13																																																																					13										
D14																																																																					14										
D15	15																																																																														
D16	Display area 1 (when "1" is set into DSPAR)																Display area 1 (when "1" is set into DSPAR)																Display area 1 (when "1" is set into DSPAR)																Display area 1 (when "1" is set into DSPAR)																*				0										
D17																																																																					1										
D18																																																																					2										
D19																																																																					3										
D20																																																																					4										
D21	Display area 1 (when "1" is set into DSPAR)																Display area 1 (when "1" is set into DSPAR)																Display area 1 (when "1" is set into DSPAR)																Display area 1 (when "1" is set into DSPAR)																*				5										
D22																																																																					6										
D23																																																																					7										
D24																																																																					8										
D25																																																																					9										
D26	Display area 1 (when "1" is set into DSPAR)																Display area 1 (when "1" is set into DSPAR)																Display area 1 (when "1" is set into DSPAR)																Display area 1 (when "1" is set into DSPAR)																*				10										
D27																																																																					11										
D28																																																																					12										
D29																																																																					13										
D30																																																																					14										
D31	15																																																																														
D32	Display area 1 (when "1" is set into DSPAR)																Display area 1 (when "1" is set into DSPAR)																Display area 1 (when "1" is set into DSPAR)																Display area 1 (when "1" is set into DSPAR)																*				16										
D33																																																																					17										
D34																																																																					18										
D35																																																																					19										
D36																																																																					20										
D37	21																																																																														
D38	22																																																																														
D39	23																																																																														
D40	24																																																																														
D41	25																																																																														
D42	26																																																																														
D43	27																																																																														
D44	28																																																																														
D45	29																																																																														
D46	30																																																																														
D47	31																																																																														
D48	32																																																																														
D49	33																																																																														
D50	34																																																																														
D51	35																																																																														
D52	36																																																																														
D53	37																																																																														
D54	38																																																																														
D55	39																																																																														
D56	40																																																																														
D57	41																																																																														
D58	42																																																																														
D59	43																																																																														
D60	44																																																																														
D61	45																																																																														
D62	46																																																																														
D63	47																																																																														
D64	48																																																																														
D65	49																																																																														
D66	50																																																																														
D67	51																																																																														
D68	52																																																																														
D69	53																																																																														
D70	54																																																																														
D71	55																																																																														
D72	56																																																																														
D73	57																																																																														
D74	58																																																																														
D75	59																																																																														
D76	60																																																																														
D77	61																																																																														
D78	62																																																																														
D79	63																																																																														
D80	64																																																																														
D81	65																																																																														
D82	66																																																																														

Fig. 5.12.5.4 1/16 duty and 5 × 5 dots display memory map

\* In the E0C88308, an area of 00Fx39H–00Fx42H (x = 8–DH) is secured as general purpose RAM with read/write capabilities that does not affect the display.

Address/Data bit	0								1								2								3								4		COM																																																																																														
	0	1	2	3	4	5	6	7	8	9	A	B	C	D	E	F	0	1	2	3	4	5	6	7	8	9	A	B	C	D	E	F	0	1		2	3	4	5	6	7	8	9	A	B	C	D	E	F	0	1	2	3	4	5	6	7																																																																								
D0																																																																	D7																																																																
D1																																																																	D8																																																																
D2																																																																	D9																																																																
D3																																																																	DA																																																																
D4																																																																	DB																																																																
D5																																																																	DC																																																																
D6																																																																	DD																																																																
D7																																																																	DE																																																																
D0																																																																	DF																																																																
D1																																																																	E0																																																																
D2																																																																	E1																																																																
D3																																																																	E2																																																																
D4																																																																	E3																																																																
D5																																																																	E4																																																																
D6																																																																	E5																																																																
D7																																																																	E6																																																																
D0																																																																	E7																																																																
D1																																																																	E8																																																																
D2																																																																	E9																																																																
D3																																																																	EA																																																																
D4																																																																	EB																																																																
D5																																																																	EC																																																																
D6																																																																	ED																																																																
D7																																																																	EE																																																																
D0																																																																	EF																																																																
D1																																																																	F0																																																																
D2																																																																	F1																																																																
D3																																																																	F2																																																																
D4																																																																	F3																																																																
D5																																																																	F4																																																																
D6																																																																	F5																																																																
D7																																																																	F6																																																																
D0																																																																	F7																																																																
D1																																																																	F8																																																																
D2																																																																	F9																																																																
D3																																																																	FA																																																																
D4																																																																	FB																																																																
D5																																																																	FC																																																																
D6																																																																	FD																																																																
D7																																																																	FE																																																																
D0																																																																	FF																																																																
D1																																																																	00																																																																
D2																																																																	01																																																																
D3																																																																	02																																																																
D4																																																																	03																																																																
D5																																																																	04																																																																
D6																																																																	05																																																																
D7																																																																	06																																																																
D0																																																																	07																																																																
D1																																																																	08																																																																
D2																																																																	09																																																																
D3																																																																	0A																																																																
D4																																																																	0B																																																																
D5																																																																	0C																																																																
D6																																																																	0D																																																																
D7																																																																	0E																																																																
D0																																																																	0F																																																																
D1																																																																	10																																																																
D2																																																																	11																																																																
D3																																																																	12																																																																
D4																																																																	13																																																																
D5																																																																	14																																																																
D6																																																																	15																																																																
D7																																																																	16																																																																
D0																																																																	17																																																																
D1																																																																	18																																																																
D2																																																																	19																																																																
D3																																																																	1A																																																																
D4																																																																	1B																																																																
D5																																																																	1C																																																																
D6																																																																	1D																																																																
D7																																																																	1E																																																																
D0																																																																	1F																																																																
D1																																																																	20																																																																
D2																																																																	21																																																																
D3																																																																	22																																																																
D4																																																																	23																																																																
D5																																																																	24																																																																
D6																																																																	25																																																																
D7																																																																	26																																																																
D0																																																																	27																																																																
D1																																																																	28																																																																
D2																																																																	29																																																																
D3																																																																	2A																																																																
D4																																																																	2B																																																																
D5																																																																	2C																																																																
D6																																																																	2D																																																																
D7																																																																	2E																																																																
D0																																																																	2F																																																																
D1																																																																	30																																																																
D2																																																																	31																																																																
D3																																																																	32																																																																
D4																																																																	33																																																																
D5																																																																	34																																																																
D6																																																																	35																																																																
D7																																																																	36																																																																
D0																																																																	37																																																																
D1																																																																	38																																																																
D2																																																																	39																																																																
D3																																																																	3A																																																																
D4																																																																	3B																																																																
D5																																																																	3C																																																																
D6																																																																	3D																																																																
D7																																																																	3E																																																																
D0																																																																	3F																																																																
D1																																																																	40																																																																
D2																																																																	41																																																																
D3																																																																	42																																																																
D4																																																																	43																																																																
D5																																																																	44																																																																
D6																																																																	45																																																																
D7																																																																	46																																																																
D0																																																																	47																																																																
D1																																																																	48																																																																
D2																																																																	49																																																																
D3																																																																	4A																																																																
D4																																																																	4B																																																																
D5																																																																	4C																																																																
D6																																																																	4D																																																																
D7																																																																	4E																																																																
D0																																																																	4F																																																																
D1																																																																	50																																																																
D2																																																																	51																																																																
D3																																																																	52																																																																
D4																																																																	53																																																																
D5																																																																	54																																																																
D6																																																																	55																																																																
D7																																																																	56																																																																
D0																																																																	57																																																																
D1																																																																	58																																																																
D2																																																																	59																																																																
D3																																																																	5A																																																																
D4																																																																	5B																																																																
D5																																																																	5C																																																																
D6																																																																	5D																																																																
D7																																																																	5E																																																																
D0																																																																	5F																																																																
D1																																																																	60																																																																
D2																																																																	61																																																																
D3																																																																	62																																																																
D4																																																																	63																																																																
D5																																																																	64																																																																
D6																																																																	65																																																																
D7																																																																	66																																																																

Fig. 5.12.5.5 1/8 duty and 5 × 8 dots display memory map

\* In the E0C88308, an area of 00F<sub>x</sub>39H–00F<sub>x</sub>42H (x = 8 and 0AH) is secured as general purpose RAM with read/write capabilities that does not affect the display.

## 5 PERIPHERAL CIRCUITS AND THEIR OPERATION (LCD Controller)

Address/Data bit	0								1								2								3								4				COM																																																																																																																																																																																																																																																																																																																																																																						
	0	1	2	3	4	5	6	7	8	9	A	B	C	D	E	F	0	1	2	3	4	5	6	7	8	9	A	B	C	D	E	F	0	1	2	3																																																																																																																																																																																																																																																																																																																																																																							
D0	Display area 0 (when "0" is set into DSPAR)																																D7	Display area 0 (when "0" is set into DSPAR)																																D6	Display area 1 (when "1" is set into DSPAR)																																D5	Display area 1 (when "1" is set into DSPAR)																																D4	Display area 1 (when "1" is set into DSPAR)																																D3	Display area 1 (when "1" is set into DSPAR)																																D2	Display area 1 (when "1" is set into DSPAR)																																D1	Display area 1 (when "1" is set into DSPAR)																																D0	Display area 1 (when "1" is set into DSPAR)																																																																																																																																		
D1																																																																																																																																																																																																																																																																																																																																																																																																											
D2																																																																																																																																																																																																																																																																																																																																																																																																											
D3																																																																																																																																																																																																																																																																																																																																																																																																											
00F800H	Display area 0 (when "0" is set into DSPAR)																																00F842H	Display area 0 (when "0" is set into DSPAR)																																00F900H	Display area 0 (when "0" is set into DSPAR)																																00F942H	Display area 0 (when "0" is set into DSPAR)																																00FA00H	Display area 0 (when "0" is set into DSPAR)																																00FA42H	Display area 0 (when "0" is set into DSPAR)																																00FB00H	Display area 0 (when "0" is set into DSPAR)																																00FB42H	Display area 0 (when "0" is set into DSPAR)																																00FC00H	Display area 0 (when "0" is set into DSPAR)																																00FC42H	Display area 0 (when "0" is set into DSPAR)																																00FD00H	Display area 0 (when "0" is set into DSPAR)																																00FD42H	Display area 0 (when "0" is set into DSPAR)																															
D4																																																																																																																																																																																																																																																																																																																																																																																																											
D5																																																																																																																																																																																																																																																																																																																																																																																																											
D6																																																																																																																																																																																																																																																																																																																																																																																																											
D7																																																																																																																																																																																																																																																																																																																																																																																																											
SEG 0	1	2	3	4	5	6	7	8	9	10	11	12	13	14	15	16	17	18	19	20	21	22	23	24	25	26	27	28	29	30	31	32	33	34	35	36	37	38	39	40	41	42	43	44	45	46	47	48	49	50	51	52	53	54	55	56	57	58	59	60	61	62	63	64	65	66																																																																																																																																																																																																																																																																																																																																									

Fig. 5.12.5.6 1/8 duty and 5 × 5 dots display memory map

\* In the E0C88308, an area of 00F<sub>x</sub>39H–00F<sub>x</sub>42H (x = 8, 9, BH and CH) is secured as general purpose RAM with read/write capabilities that does not affect the display.

### 5.12.6 Display control

The display status of the built-in LCD driver and the contrast adjustment can be controlled with the built-in LCD controller. The LCD display status can be selected by display control registers LCDC0 and LCDC1. Setting the value and display status are shown in Table 5.12.6.1.

Table 5.12.6.1 LCD display control

LCDC1	LCDC0	LCD display
1	1	All LCDs lit (Static)
1	0	All LCDs out (Dynamic)
0	1	Normal display
0	0	Drive OFF

All the dots in the LCD display can be turned on or off directly by the drive waveform output from the LCD driver, and data in the display memory is not changed. Also, since the common terminal at this time is set to static drive when all the dots are on and is set to dynamic drive when they are off, this function can be used as follows:

- (1) Since all dots on is binary output (VC5 and VSS) with static drive, the common/segment terminal can be used as a monitor terminal for the OSC1 oscillation frequency adjustment.
- (2) Since all dots off is dynamic drive, you can brink the entire LCD display without changing display memory data.

Selecting LCD drive OFF turns the LCD drive power circuit OFF and all the VC1–VC5 terminals go to Vss level. However, if external power supply has been selected by the mask option, the VC1–VC5 shift to floating status when drive is turned OFF. Furthermore, when the SLP instruction is executed, registers LCDC0 and LCDC1 are automatically reset to "0" (set to drive off) by hardware.

The LCD contrast can be adjusted in 16 stages. This adjustment is done by the contrast adjustment register LC0–LC3, and the setting values correspond to the contrast as shown in Table 5.12.6.2. However, if external power supply has been selected by the mask option, the contrast adjustment register LC0–LC3 is ineffective and contrast adjustment cannot be done.

Table 5.12.6.2 LCD contrast adjustment

LC3	LC2	LC1	LC0	Contrast
1	1	1	1	Dark
1	1	1	0	↑
1	1	0	1	
:	:	:	:	
0	0	1	0	
0	0	0	1	↓
0	0	0	0	Light

### 5.12.7 CL and FR outputs

In order for the E0C883xx to handle connection to an externally expanded LCD driver, output ports R25 and R26 can be used to output a CL signal (LCD synchronous signal) and FR signal (LCD frame signal), respectively.

The configuration of output ports R25 and R26 are shown in Figure 5.12.7.1.

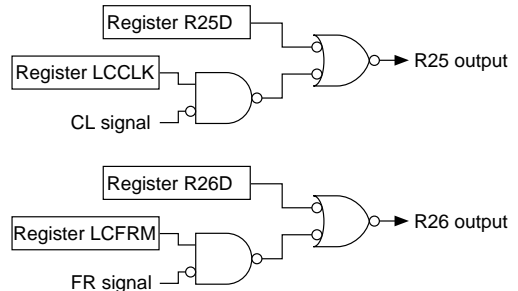

Fig. 5.12.7.1 Configuration of R25 and R26

The output control for the CL signal is done by the register LCCLK. When you set "1" for the LCCLK, the CL signal is output from the output port terminal R25, when "0" is set, the HIGH (VDD) level is output. At this time, "1" must always be set for the data register R25D.

The output control for the FR signal is done by the register LCFRM. When you set "1" for the LCFRM, the FR signal is output from the output port terminal R26, when "0" is set, the HIGH (VDD) level is output. At this time, "1" must always be set for the data register R26D.

The frequencies of each signal are changed as shown in Table 5.12.7.1 according to the drive duty selection.

Table 5.12.7.1 Frequencies of CL and FR signals

Drive duty	CL signal (Hz)	FR signal (Hz)
1/32	2,048	32
1/16	1,024	32
1/8	1,024	64

Since the signals are generated asynchronously from the registers LCCLK and LCFRM, when the signals are turned ON or OFF by the register settings, a hazard of a 1/2 cycle or less is generated. Figure 5.12.7.2 shows the output waveforms of the CL and FR signals.

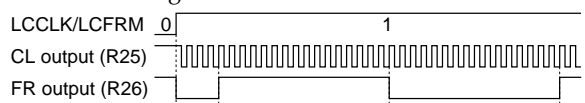

Fig. 5.12.7.2 Output waveforms of CL and FR signals (when 1/16 duty is selected)

5.12.8 Control of LCD controller

Table 5.12.8.1 shows the LCD controller control bits.

Table 5.12.8.1 LCD controller control bits

Address	Bit	Name	Function	1	0	SR	R/W	Comment			
00FF10	D7	–	–	–	–	–		Constantry "0" when being read			
	D6	–	–	–	–	–					
	D5	–	–	–	–	–					
	D4	LCCLK	CL output control for expanded LCD driver		On	Off	0	R/W			
	D3	LCFRM	FR output control for expanded LCD driver		On	Off	0	R/W			
	D2	DTFNT	LCD dot font selection		5 × 5 dots	5 × 8 dots	0	R/W			
	D1	LDUTY	LCD drive duty selection		1/16 duty	1/32 duty	0	R/W			
D0	SGOUT	R/W register		1	0	0	R/W	Reserved register			
00FF11	D7	–	–	–	–	–		"0" when being read			
	D6	DSPAR	LCD display memory area selection		Display area 1	Display area 0	0	R/W			
	D5	LCDC1	LCD display control				0	R/W	These bits are reset to (0, 0) when SLP instruction is executed.		
			LCDC1	LCDC0						LCD display	
			1	1						All LCDs lit	
			1	0						All LCDs out	
	D4	LCDC0					0	R/W			
	0		1	Normal display							
	0		0	Drive off							
D3	LC3	LCD contrast adjustment				0	R/W				
D2	LC2	LC3	LC2						LC1	LC0	Contrast
		1	1						1	1	Dark
D1	LC1	1	1						1	0	:
	:	:	:						:	:	:
D0	LC0	0	0	0	0	Light					

\*1 When 1/8 duty has been selected by mask option, setting of this register becomes invalid.

**LDUTY: 00FF10H•D1**

Selects the drive duty.

- When "1" is written: 1/16 duty
- When "0" is written: 1/32 duty
- Reading: Valid

When "1/32 & 1/16 duty" is selected by the mask option, select whether the drive duty will be 1/32 or 1/16.

When "0" is written to LDUTY, 1/32 duty is selected and the combined common/segment output terminal is switched to the common terminal.

When "1" is written to LDUTY, 1/16 duty is selected and the combined common/segment output terminal is switched to the segment terminal.

When "1/8 duty" is selected by the mask option, the combined common/segment terminals are fixed to the segment terminals and the setting of LDUTY becomes invalid.

The correspondence between the display memory bits set according to the drive duty, and the common/segment terminals are shown in Figures 5.12.5.1–5.12.5.6.

At initial reset, LDUTY is set to "0" (1/32 duty).

**DTFNT: 00FF10H•D2**

Selects the dot font.

- When "1" is written: 5 × 5 dots
- When "0" is written: 5 × 8 dots
- Reading: Valid

Select 5 × 8 dots or 5 × 5 dots type for the display memory area.

When "0" is written to DTFNT, 5 × 8 dots is selected and when "1" is written, 5 × 5 dots is selected.

The correspondence between the display memory bits set according to the dot font, and the common/segment terminals are shown in Figures 5.12.5.1–5.12.5.6.

At initial reset, DTFNT is set to "0" (5 × 8 dots).



**DSPAR: 00FF11H•D6**

Selects the display area.

When "1" is written: Display area 1  
 When "0" is written: Display area 0  
 Reading: Valid

Selects which display area is secured for two screens in the display memory, will be displayed when 1/16 or 1/8 duty is selected.

When "0" is written to DSPAR, display area 0 is selected and when "1" is written, display area 1 is selected.

When 1/32 duty is selected, since the display area is only for one screen, the setting of DSPAR becomes invalid.

The correspondence between the display memory bits set according to the display area, and the common/segment terminals are shown in Figures 5.12.5.1–5.12.5.6.

At initial reset, DSPAR is set to "0" (display area 0).

**LCDC0, LCDC1: 00FF11H•D4, D5**

Controls the LCD display.

Table 5.12.8.2 LCD display control

LCDC1	LCDC0	LCD display
1	1	All LCDs lit (Static)
1	0	All LCDs out (Dynamic)
0	1	Normal display
0	0	Drive OFF

The four settings mentioned above can be made without changing the display memory data. At initial reset and in the SLEEP status, this register is set to "0" (drive off).

**LC0–LC3: 00FF11H•D0–D3**

Adjusts the LCD contrast.

Table 5.12.8.3 LCD contract adjustment

LC3	LC2	LC1	LC0	Contrast
1	1	1	1	Dark
1	1	1	0	↑
1	1	0	1	
1	1	0	0	
1	0	1	1	
1	0	1	0	
1	0	0	1	
1	0	0	0	
0	1	1	1	
0	1	1	0	
0	1	0	1	
0	1	0	0	
0	0	1	1	
0	0	1	0	
0	0	0	1	↓
0	0	0	0	Light

The contrast can be adjusted in 16 stages as mentioned above. This adjustment changes the drive voltage on terminals VC1–VC5.

At initial reset, this register is set to "0".

*Note: If external power supply has been selected by the mask option, the contrast adjustment register LC0–LC3 is ineffective.*

**LCCLK: 00FF10H•D4**

Controls the CL signal output.

When "1" is written: CL signal output  
 When "0" is written: HIGH level (DC) output  
 Reading: Valid

LCCLK is the output control register for CL signal. When "1" is set, the CL signal is output from the output port terminal R25 and when "0" is set, HIGH (VDD) level is output. At this time, "1" must always be set for the data register R25D.

At initial reset, LCCLK is set to "0" (HIGH level output).

**LCFRM: 00FF10H•D3**

Controls the FR signal output.

When "1" is written: FR signal output  
 When "0" is written: HIGH level (DC) output  
 Reading: Valid

LCFRM is the output control register for FR signal. When "1" is set, the FR signal is output from the output port terminal R26 and when "0" is set, HIGH (VDD) level is output. At this time, "1" must always be set for the data register R26D.

At initial reset, LCFRM is set to "0" (HIGH level output).

**5.12.9 Programming notes**

- (1) Since the CL and FR signals are generated asynchronously from the output control registers LCCLK and LCFRM, when the signals is turned ON or OFF by setting of the registers LCCLK and LCFRM, a hazard of a 1/2 cycle or less is generated.
- (2) When the SLP instruction is executed, display control registers LCDC0 and LCDC1 are automatically reset to "0" by hardware. Furthermore, in the SLEEP status, HIGH (VDD) level is output for the CL and FR signals. (When registers R25D and R26D are set to "1".)

### 5.13 Sound Generator

#### 5.13.1 Configuration of sound generator

The E0C883xx has a built-in sound generator for generating BZ (buzzer) signal. BZ signals generated from the sound generator can be output from the R50 output port terminal. Aside permitting the respective setting of the buzzer signal frequency and sound level (duty adjustment) to 8 stages, it permits the adding of a digital envelope by means of duty ratio control. It also has a one-shot output function for outputting key operated sounds. Figure 5.13.1.1 shows the configuration of the sound generator.

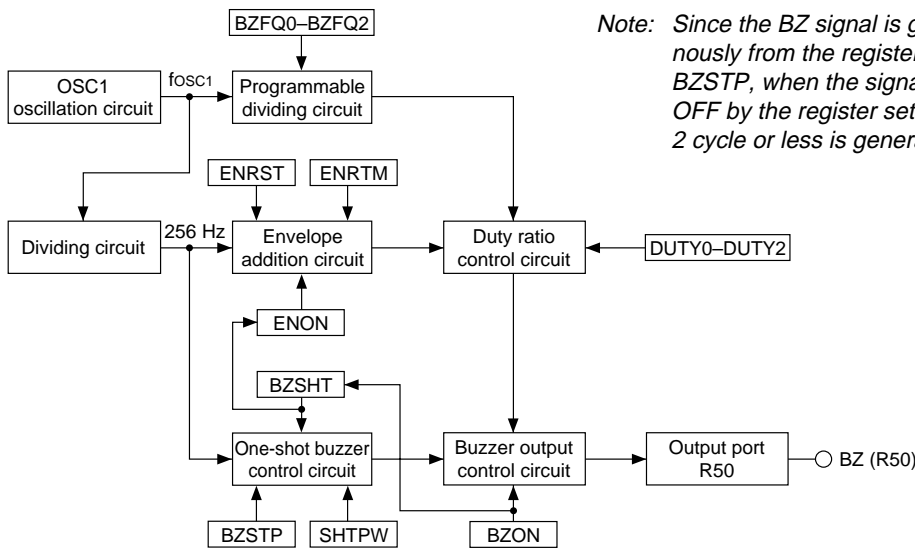

Fig. 5.13.1.1 Configuration of sound generator

#### 5.13.2 Control of buzzer output

BZ signal can be output from the R50 output port terminal. The configuration of the output port R50 is shown in Figure 5.13.2.1.

The output control for the BZ signal generated by the sound generator is done by the buzzer output control register BZON, one-shot buzzer trigger bit BZSHT and one-shot buzzer forced stop bit BZSTP. When "1" is set to BZON or BZSHT, the BZ signal is output from the R50 output port terminal and when "0" is set to BZON or "1" is set to BZSTP, the LOW (Vss) level is output. At this time, "0" must always be set for the output data register R50D. Figure 5.13.2.2 shows the output waveform of the BZ signal.

*Note: Since the BZ signal is generated asynchronously from the registers BZON, BZSHT and BZSTP, when the signal is turned ON or OFF by the register settings, a hazard of a 1/2 cycle or less is generated.*

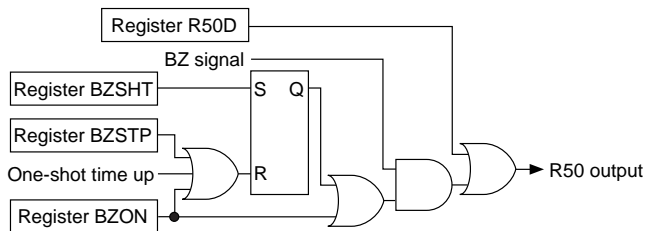

Fig. 5.13.2.1 Configuration of R50

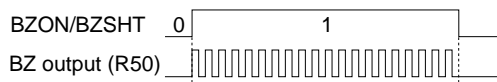

Fig. 5.13.2.2 Output waveform of BZ signal

### 5.13.3 Setting of buzzer frequency and sound level

The BZ signal is a divided signal using the OSC1 oscillation circuit (32.768 kHz) as the clock source and 8 frequencies can be selected. This selection is done by the buzzer frequency selection register BZFQ0–BZFQ2. The setting value and buzzer frequency correspondence is shown in Table 5.13.3.1. By selecting the duty ratio of the BZ signal from among 8 types, the buzzer sound level can be adjusted. This selection is made in the duty ratio selection register DUTY0–DUTY2. The setting value and duty ratio correspondence is shown in Table 5.13.3.2.

Table 5.13.3.1 Buzzer signal frequency settings

BZFQ2	BZFQ1	BZFQ0	Buzzer frequency (Hz)
0	0	0	4096.0
0	0	1	3276.8
0	1	0	2730.7
0	1	1	2340.6
1	0	0	2048.0
1	0	1	1638.4
1	1	0	1365.3
1	1	1	1170.3

Table 5.13.3.2 Duty ratio settings

Level	DUTY2	DUTY1	DUTY0	Duty ratio by buzzer frequencies (Hz)			
				4096.0	3276.8	2730.7	2340.6
				2048.0	1638.4	1365.3	1170.3
Level 1 (Max)	0	0	0	8/16	8/20	12/24	12/28
Level 2	0	0	1	7/16	7/20	11/24	11/28
Level 3	0	1	0	6/16	6/20	10/24	10/28
Level 4	0	1	1	5/16	5/20	9/24	9/28
Level 5	1	0	0	4/16	4/20	8/24	8/28
Level 6	1	0	1	3/16	3/20	7/24	7/28
Level 7	1	1	0	2/16	2/20	6/24	6/28
Level 8 (Min)	1	1	1	1/16	1/20	5/24	5/28

Duty ratio refers to the ratio of pulse width to the pulse cycle; given that HIGH level output time is TH, and low level output time is TL the BZ signal becomes TH/(TH+TL).

When DUTY0–DUTY2 have all been set to "0", the duty ratio becomes maximum and the sound level also becomes maximum. Conversely, when DUTY0–DUTY2 have all been set to "1", the duty ratio becomes minimum and the sound level also becomes minimum.

Note that the duty ratio setting differ depending on frequency. See Table 5.13.3.2.

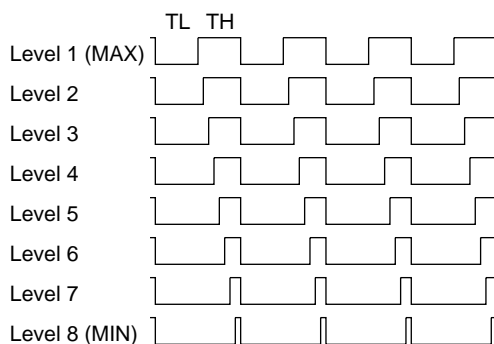

Fig. 5.13.3.1 Duty ratio of buzzer signal waveform

Note: When using the digital envelope, the DUTY0–DUTY2 setting becomes invalid.

### 5.13.4 Digital envelope

A digital envelope with duty control can be added to the BZ signal.

The envelope can be realized by staged changing of the same duty ratio as detailed in Table 5.13.3.2 in the preceding section from level 1 (maximum) to level 8 (minimum).

The addition of an envelope to the buzzer signal can be done by writing "1" to the envelope control register ENON. When "0" is written, the duty ratio is set at the level selected in DUTY0–DUTY2.

By writing "1" to ENON to turn the buzzer output ON (writing "1" to BZON), a BZ signal with a level 1 duty ratio is output, and then the duty ratio can be attenuated in stages to level 8. The attenuated envelope can be returned to level 1 by writing "1" to the envelope reset bit ENRST. When attenuated to level 8, the duty level remains at level 8 until the buzzer output is turned OFF (writing "0" to BZON) or writing "1" to ENRST.

The stage changing time for the envelope level can be selected either 125 msec or 62.5 msec by the envelope attenuation time selection register ENRTM. Figure 5.13.4.1 shows the timing chart of the digital envelope.

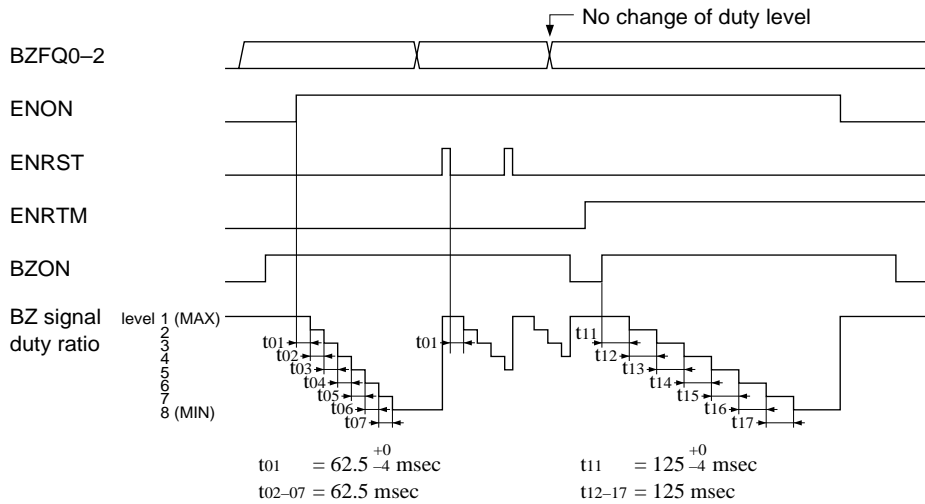

Fig. 5.13.4.1 Timing chart of digital envelope

### 5.13.5 One-shot output

The sound generator has a built-in one-shot output function for outputting a short duration buzzer signal for key operation sounds and similar effects. Either 125 msec or 31.25 msec can be selected by the one-shot buzzer duration selection register SHTPW for buzzer signal output time.

The output control of the one-shot buzzer is done by writing "1" to the one-shot buzzer trigger BZSHT, then the BZ signal is output in synchronization with the internal 256 Hz signal from the R50 output port terminal. Thereafter, when the set time has elapsed, the BZ signal in synchronization with the 256 Hz signal automatically goes OFF in the same manner.

The BZSHT can be read to determine status. When BZSHT is "1", it indicates a BUSY status (during one-shot output) and when BZSHT is "0", it indicates a READY status (during stop).

When you want to turn the BZ signal OFF prior to the elapse of the set time, the BZ signal can be immediately stopped (goes OFF in asynchronization with 256 Hz signal) by writing "1" to the one-shot forced stop bit BZSTP.

Since the one-shot output has a short duration, an envelope cannot be added. (When "1" is written to BZSHT, ENON is automatically reset to "0".) Consequently, only the frequency and sound level can be set for one-shot output.

The control for the one-shot output is invalid during normal buzzer output.

Figure 5.13.5.1 shows the timing chart of the one-shot output.

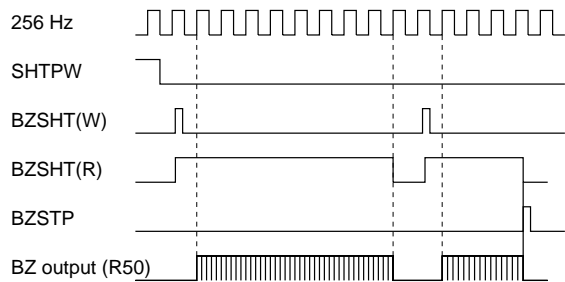

Fig. 5.13.5.1 Timing chart of one-shot output

5.13.6 Control of sound generator

Table 5.13.6.1 shows the sound generator control bits.

Table 5.13.6.1 Sound generator control bits

Address	Bit	Name	Function	1	0	SR	R/W	Comment	
00FF44	D7	–	–	–	–	–		Constrany "0" when being read	
	D6	BZSTP	One-shot buzzer forcibly stop	Forcibly stop	No operation	–	W		
	D5	BZSHT	One-shot buzzer trigger/status	R	Busy	Ready	0		R/W
				W	Trigger	No operation			
	D4	SHTPW	One-shot buzzer duration width selection	125 msec	31.25 msec	0	R/W		
	D3	ENRTM	Envelope attenuation time	1 sec	0.5 sec	0	R/W		
	D2	ENRST	Envelope reset	Reset	No operation	–	W		"0" when being read
	D1	ENON	Envelope On/Off control	On	Off	0	R/W		*1
D0	BZON	Buzzer output control	On	Off	0	R/W			
00FF45	D7	–	–	–	–	–		"0" when being read	
	D6	DUTY2	Buzzer signal duty ratio selection					0	R/W
			DUTY2–1      Buzzer frequency (Hz)						
			2	1	0	4096.0 3276.8 2730.7 2340.6			
						2048.0 1638.4 1365.3 1170.3			
	D5	DUTY1	0	0	0	8/16 8/20 12/24 12/28		0	R/W
			0	0	1	7/16 7/20 11/24 11/28			
			0	1	0	6/16 6/20 10/24 10/28			
			0	1	1	5/16 5/20 9/24 9/28			
	D4	DUTY0	1	0	0	4/16 4/20 8/24 8/28		0	R/W
			1	0	1	3/16 3/20 7/24 7/28			
1			1	0	2/16 2/20 6/24 6/28				
1			1	1	1/16 1/20 5/24 5/28				
D3	–	–	–	–	–		"0" when being read		
D2	BZFQ2	Buzzer frequency selection					0	R/W	
		BZFQ2	BZFQ1	BZFQ0	Frequency (Hz)				
D1	BZFQ1	0	0	0	4096.0		0	R/W	
		0	0	1	3276.8				
		0	1	0	2730.7				
		0	1	1	2340.6				
D0	BZFQ0	1	0	0	2048.0		0	R/W	
		1	0	1	1638.4				
		1	1	0	1365.3				
		1	1	1	1170.3				

\*1 Reset to "0" during one-shot output.

**BZON: 00FF44H•D0**

Controls the BZ signal output.

- When "1" is written: BZ signal output
- When "0" is written: LOW level (DC) output
- Reading: Valid

BZON is the output control register for BZ signal. When "1" is set, the BZ signal is output from the output port terminal R50 and when "0" is set, LOW (Vss) level is output. At this time, "0" must always be set for the data register R50D. At initial reset, BZON is set to "0" (LOW level output).

**BZFQ0–BZFQ2: 00FF45H•D0–D2**

Selects the BZ signal frequency.

Table 5.13.6.2 Buzzer frequency settings

BZFQ2	BZFQ1	BZFQ0	Buzzer frequency (Hz)
0	0	0	4096.0
0	0	1	3276.8
0	1	0	2730.7
0	1	1	2340.6
1	0	0	2048.0
1	0	1	1638.4
1	1	0	1365.3
1	1	1	1170.3

The buzzer frequency can be selected from among the above 8 types that have divided the OSC1 clock. At initial reset, this register is set at "0" (4096.0 Hz).

**DUTY0–DUTY2: 00FF45H•D4–D6**

Selects the duty ratio of the BZ signal.

Table 5.13.6.3 Duty ratio settings

Level	DUTY2	DUTY1	DUTY0	Duty ratio by buzzer frequencies (Hz)			
				4096.0 2048.0	3276.8 1638.4	2730.7 1365.3	2340.6 1170.3
Level 1 (Max)	0	0	0	8/16	8/20	12/24	12/28
Level 2	0	0	1	7/16	7/20	11/24	11/28
Level 3	0	1	0	6/16	6/20	10/24	10/28
Level 4	0	1	1	5/16	5/20	9/24	9/28
Level 5	1	0	0	4/16	4/20	8/24	8/28
Level 6	1	0	1	3/16	3/20	7/24	7/28
Level 7	1	1	0	2/16	2/20	6/24	6/28
Level 8 (Min)	1	1	1	1/16	1/20	5/24	5/28

The buzzer sound level can be adjusted by selecting the duty ratio from among the above 8 types. However, when the envelope has been set to ON (ENON = "1"), this setting becomes invalid.

At initial reset, this register is set to "0" (level 1).

**ENRST: 00FF44H•D2**

Resets the envelope.

- When "1" is written: Reset
- When "0" is written: No operation
- Reading: Always "0"

The envelope is reset by writing "1" to ENRST and the duty ratio returns to level 1 (maximum). Writing "0" to ENRST and writing "1" when an envelope has not been added become invalid. Since ENRST is exclusively for writing, it always becomes "0" during reading.

**ENON: 00FF44H•D1**

Controls the addition of an envelope to the BZ signal.

- When "1" is written: ON
- When "0" is written: OFF
- Reading: Valid

By writing "1" to ENON, an envelope can be added to BZ signal output. When "0" is written, an envelope is not added and the BZ signal is fixed at the duty ratio selected in DUTY0–DUTY2. At initial reset and when "1" is written to BZSHT, ENON is set to "0" (OFF).

**ENRTM: 00FF44H•D3**

Selects the envelope attenuation time that is added to the BZ signal.

- When "1" is written: 1.0 sec  
(125 msec × 7 = 875 msec)
- When "0" is written: 0.5 sec  
(62.5 msec × 7 = 437.5 msec)
- Reading: Valid

The attenuation time of the digital envelope is determined by the time for changing the duty ratio. The duty ratio is changed in 125 msec (8 Hz) units when "1" is written to ENRTM and in 62.5 msec (16 Hz) units, when "0" is written.

This setting becomes invalid when an envelope has been set to OFF (ENON = "0"). At initial reset, ENRTM is set to "0" (0.5 sec).

**SHTPW: 00FF44H•D4**

Selects the output duration width of the one-shot buzzer.

- When "1" is written: 125 msec
- When "0" is written: 31.25 msec
- Reading: Valid

The one-shot buzzer output duration width is set to 125 msec when "1" is written to SHTPW and 62.5 msec, when "0" is written.

At initial reset, SHTPW is set to "0" (31.25 msec).

***BZSHT: 00FF44H•D5***

Controls the one-shot buzzer output.

When "1" is written:	Trigger
When "0" is written:	No operation
When "1" is read:	Busy
When "0" is read:	Ready

Writing "1" into BZSHT causes the one-shot output circuit to operate and the BZ signal to be output. The buzzer output is automatically turned OFF after the time set by SHTPW has elapsed. At this time, "0" must always be set for the data register R50D.

The one-shot output is only valid when the normal buzzer output is OFF (BZON = "0") status. The trigger is invalid during ON (BZON = "1") status. When a re-trigger is assigned during a one-shot output, the one-shot output time set with SHTPW is measured again from that point. (time extension)  
The operation status of the one-shot output circuit can be confirmed by reading BZSHT, when the one-shot output is ON (busy), BZSHT reads "1" and when the output is OFF (ready), it reads "0".  
At initial reset, BZSHT is set to "0" (ready).

***BZSTP: 00FF44H•D6***

Forcibly stops the one-shot buzzer output.

When "1" is written:	Forcibly stop
When "0" is written:	No operation
Reading:	Constantly "0"

By writing "1" into BZSTP, the one-shot buzzer output can be stopped prior to the elapsing of the time set with SHTPW.

Writing "0" is invalid and writing "1" except during one-shot output is also invalid.

When "1" is written to BZSHT and BZSTP simultaneously, BZSTP takes precedence and one-shot output becomes stop status.

Since BZSTP is for writing only, during readout it is constantly set to "0".

***5.13.7 Programming notes***

- (1) Since the BZ signal is generated asynchronously from the register BZON, when the signal is turned ON or OFF by the register setting, a hazard of a 1/2 cycle or less is generated.
- (2) The SLP instruction has executed when the BZ signal is in the enable status (BZON = "1" or BZSHT = "1"), an unstable clock is output from the R50 output port terminal at the time of return from the SLEEP status. Consequently, when shifting to the SLEEP status, you should set the BZ signal to the disable status (BZON = BZSHT = "0") prior to executing the SLP instruction.
- (3) The one-shot output is only valid when the normal buzzer output is OFF (BZON = "0") status. The trigger is invalid during ON (BZON = "1") status.

## 5.14 Analog Comparator

### 5.14.1 Configuration of analog comparator

The E0C883xx has an MOS input analog comparator built into two channels. The respective analog comparators have two differential input terminals (inverted input terminal CMPMx and non-inverted input terminal CMPPx) that are available for general purpose use.

Figure 5.14.1.1 shows the configuration of the analog comparator.

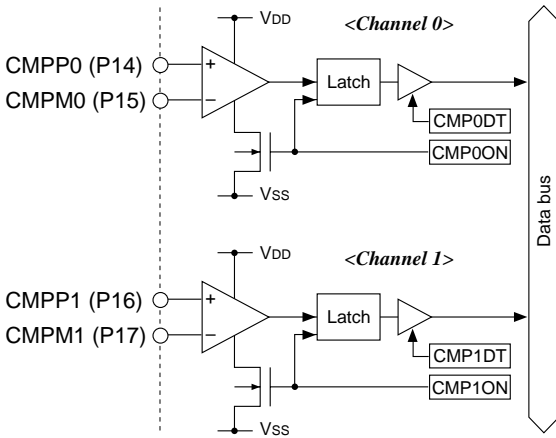

Fig. 5.14.1.1 Configuration of analog comparator

Since the input terminals of the analog comparator CMPP0, CMPM0, CMPP1 and CMPM1 are common to I/O ports P14–P17, when using as the input terminal for the analog comparator, "0" (input mode) must be written to I/O control registers IOC14–IOC17.

Table 5.14.1.1 Input terminal configuration

Terminal	When analog comparator is used
P14	CMPP0
P15	CMPM0
P16	CMPP1
P17	CMPM1

### 5.14.2 Mask option

Since the input terminals of the analog comparator are common to the I/O ports, the mask option for the I/O port corresponding to the channel to be used must be set to "Gate direct".

#### I/O ports pull-up resistor

P14 (CMPP0) ...	<input type="checkbox"/> With resistor	<input checked="" type="checkbox"/> Gate direct
P15 (CMPM0) ..	<input type="checkbox"/> With resistor	<input checked="" type="checkbox"/> Gate direct
P16 (CMPP1) ...	<input type="checkbox"/> With resistor	<input checked="" type="checkbox"/> Gate direct
P17 (CMPM1) ..	<input type="checkbox"/> With resistor	<input checked="" type="checkbox"/> Gate direct

\* "✓" above shows an example of both channels being used.

### 5.14.3 Analog comparator operation

By writing "1" to the analog comparator control register CMPxON, the analog comparator goes ON, and the analog comparator starts comparing the external voltages that have been input to the two differential input terminals CMPPx and CMPMx. The result can be read from the comparator comparison result detection bit CMPxDT through the latch and when CMPPx (+) > CMPMx (-), it is "1" and when CMPPx (+) < CMPMx (-), it is "0". After the analog comparator has been turned ON, a maximum time of 3 msec is necessary until output stabilizes. Consequently, you should allow an adequate waiting time after turning the analog comparator ON, before reading the comparison result.

When the analog comparator is turned OFF, the comparison result at that point will be latched and the concerned data can be read thereafter, until the analog comparator is turned ON.

You should turn the analog comparator OFF, when it is not necessary, so as to reduce current consumption.

See "7 ELECTRICAL CHARACTERISTICS" for the input voltage range.

*Note:* Since the input terminals of the analog comparator are common to the I/O ports, the I/O control registers (IOC14–IOC17) corresponding to the channel to be used must be set to the input mode.



### 5.14.4 Control of analog comparator

Table 5.14.4.1 shows the analog comparator control bits.

Table 5.14.4.1 Analog comparator control bits

Address	Bit	Name	Function	1	0	SR	R/W	Comment
00FF13	D7	–	–	–	–	–		Constantly "0" when being read
	D6	–	–	–	–	–		
	D5	–	–	–	–	–		
	D4	–	–	–	–	–		
	D3	CMP1ON	Comparator 1 On/Off control	On	Off	0	R/W	
	D2	CMP0ON	Comparator 0 On/Off control	On	Off	0	R/W	
	D1	CMP1DT	Comparator 1 data	+ > -	+ < -	0	R	
	D0	CMP0DT	Comparator 0 data	+ > -	+ < -	0	R	

#### CMP0ON, CMP1ON: 00FF13H•D2, D3

Controls the analog comparator ON/OFF.

When "1" is written: ON

When "0" is written: OFF

Reading: Valid

The analog comparator 0 goes ON by writing "1" to CMP0ON and goes OFF, when "0" is written. The analog comparator 1 can be controlled with CMP1ON in the same way.

At initial reset, this register is set "0" (OFF).

#### CMP0DT, CMP1DT: 00FF13H•D0, D1

The comparison result of the analog comparator can be read out.

When "1" is read: CMPPx (+) > CMPMx (-)

When "0" is read: CMPPx (+) < CMPMx (-)

Writing: Invalid

The result of analog comparator 0 can be read from CMP0DT. When the status of external voltage input to differential input terminals CMPP0 and CMPM0 is CMPP0 (+) > CMPM0 (-), CMP0DT becomes "1" and when it is CMPP0 (+) < CMPM0 (-), CMP0DT becomes "0".

As the same way, the comparison result between CMPP1 and CMPM1 can be read from CMP1DT. When the analog comparator is turned OFF, the latched result immediately prior to going OFF is read out.

At initial reset, this bit is set to "1".

### 5.14.5 Programming notes

- (1) To reduce current consumption, turn the analog comparator OFF (CMP0ON = CMP1ON = "0") when it is not necessary.
- (2) After the analog comparator has been turned ON, a maximum time of 3 msec is necessary until output stabilizes. Consequently, you should allow an adequate waiting time after turning the analog comparator ON, before reading the comparison result.
- (3) Since the input terminals of the analog comparator are common to the I/O ports, the I/O control registers (IOC14–IOC17) corresponding to the channel to be used must be set to the input mode.

## 5.15 Supply Voltage Detection (SVD) Circuit

### 5.15.1 Configuration of SVD circuit

The E0C883xx has a built-in supply voltage detection (SVD) circuit configured with a 4-bit successive approximation A/D converter.

The SVD circuit has 16 sampling levels (level 0–level 15) for supply voltage, and this can be controlled by software.

In addition, an initial reset signal can be generated when the supply voltage drops to level 0 or less.

This is selected by the mask option.

Figure 5.15.1.1 shows the configuration of the SVD circuit.

### 5.15.2 Operation of SVD circuit

#### ■ Sampling control of the SVD circuit

The SVD circuit has two operation modes: continuous sampling and 1/4 Hz auto-sampling mode.

Operation mode selection is done by the SVD control registers SVDON and SVDSP as shown in Table 5.15.2.1. When both bits of SVDON and SVDSP are set to "1", continuous sampling is selected.

Table 5.15.2.1 Correspondence between control register and operation mode

SVDON	SVDSP	Operating mode
0	0	SVD circuit OFF
0	1	1/4 Hz auto-sampling ON
1	×	Continuous sampling ON

In both operation modes, reading SVDON can confirm whether the SVD circuit is operating (BUSY) or on standby (READY); "1" indicates BUSY and "0" indicates READY.

When executing an SLP instruction while the SVD circuit is operating, the stop operation of the OSC1 oscillation circuit is kept waiting until the sampling is completed. The two bits of SVDON and SVDSP are automatically reset to "0" by hardware while waiting for completion of sampling.

To reduce current consumption, turn the SVD circuit OFF when it is not necessary.

#### ■ Detection result

The SVD circuit A/D converts the supply voltage (VDD–VSS) by 4-bit resolution and sets the result thereof into the SVD0–SVD3 register.

The data in SVD0–SVD3 correspond to the detection levels as shown in Table 5.15.2.2 and the detection data is maintained until the next sampling.

For the correspondence between the detection level and the supply voltage, see "7 ELECTRICAL CHARACTERISTICS".

An interval of 7.8 msec ( $f_{OSC1} = 32.768 \text{ kHz}$ ) is required from the start of supply voltage sampling by the SVD circuit to completion by writing the result into SVD0–SVD3. Therefore, when reading SVD0–SVD3 before sampling is finished, the previous result will be read.

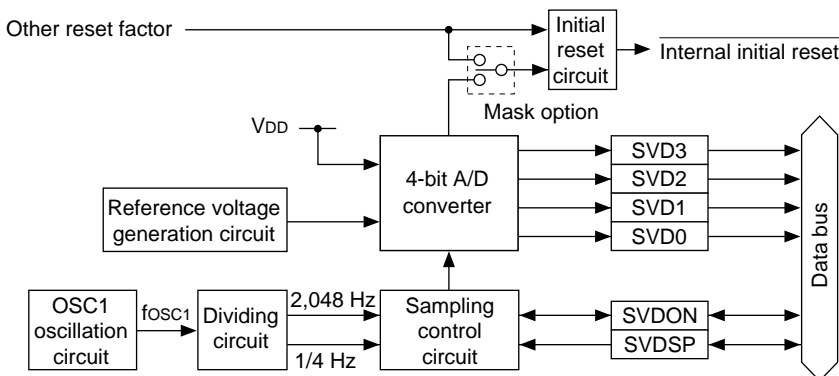

Fig.5.15.1.1 Configuration of SVD circuit

Table 5.15.2.2 Supply voltage detection results

SVD3	SVD2	SVD1	SVD0	Detection level
1	1	1	1	Level 15
1	1	1	0	Level 14
1	1	0	1	Level 13
1	1	0	0	Level 12
1	0	1	1	Level 11
1	0	1	0	Level 10
1	0	0	1	Level 9
1	0	0	0	Level 8
0	1	1	1	Level 7
0	1	1	0	Level 6
0	1	0	1	Level 5
0	1	0	0	Level 4
0	0	1	1	Level 3
0	0	1	0	Level 2
0	0	0	1	Level 1
0	0	0	0	Level 0

### ■ Timing of sampling

Next, we will explain the timing for two operation modes.

#### (1) Continuous sampling mode

This mode is selected when "1" is written to SVDON and sampling of the supply voltage is done continuously in 7.8 msec cycles.

The SVD circuit starts operation in synchronization with the internal 2,048 Hz signal and performs one sampling in 16 clock cycles.

The sampling is done continuously without setting the standby time and the result is latched to SVD0–SVD3 in every 16 clock cycles. Cancellation of continuous sampling is done by writing "0" to SVDON. The SVD circuit maintains ON status until completion of sampling and then goes OFF.

After writing "0" to SVDON, SVDON reads "1" until the SVD circuit actually goes OFF.

Figure 5.15.2.1 shows the timing chart of the continuous sampling.

#### (2) 1/4 Hz auto-sampling mode

This mode is selected when "0" is written to SVDON and "1" is written to SVDSP. In this case, supply voltage sampling is done in every 4 seconds.

The sampling time is 7.8 msec as in continuous sampling, and the result in SVD0–SVD3 is updated every 4 seconds.

Cancellation of 1/4 Hz auto-sampling is done by writing "0" to SVDSP. If the SVD circuit is sampling, SVD circuit waits until completion and then turns OFF. In addition, "1" is read from SVDON while the SVD circuit is sampling.

Figure 5.15.2.2 shows the timing chart of the 1/4 Hz auto-sampling.

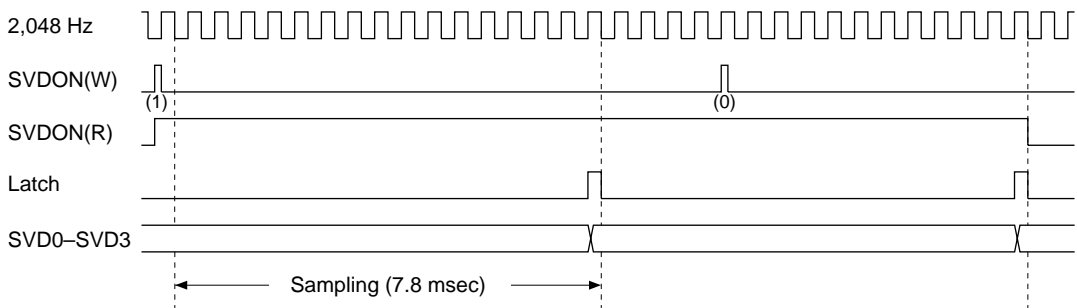

Fig. 5.15.2.1 Timing chart of continuous sampling

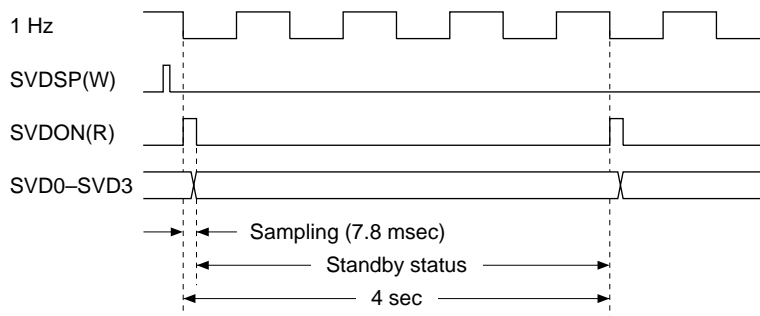

Fig. 5.15.2.2 Timing chart of 1/4 Hz auto-sampling

■ **Reset function at low voltage detection**

To avoid CPU runaway due to a supply voltage drop, an initial reset function when the supply voltage drops to level 0 or less can be selected by the mask option.

The SVD circuit shifts to continuous sampling status when it detects level 0 (SVD3–SVD0 = 0000B) four successive times. At this time, the internal initial reset signal is generated. The reset status continues until the supply voltage returns to level 2 (SVD3–SVD0 = 0010B) or higher.

When the reset status is canceled by the restoration of the supply voltage, the SVD circuit returns to its previous status. Continuous sampling status continues in case of the previous status was continuous sampling. Then CPU starts the reset exception processing.

Figure 5.15.2.3 shows the timing chart of the initial reset signal generation. (Example when using 1/4 Hz auto-sampling.)

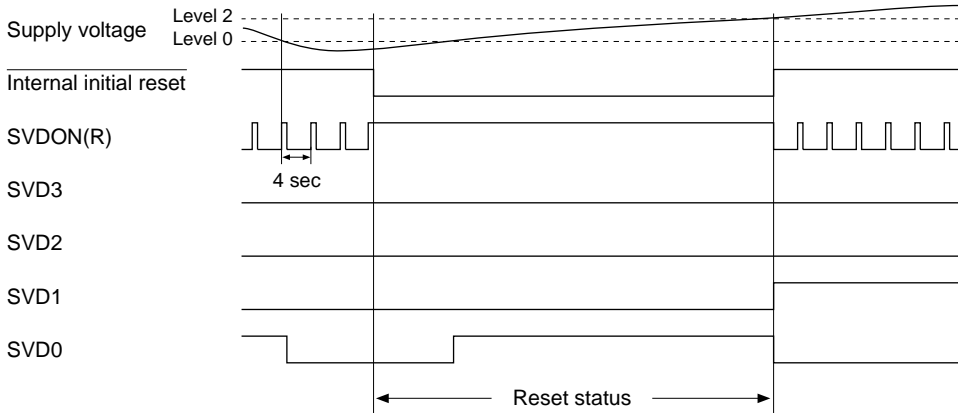

Fig. 5.15.2.3 Timing chart of the initial reset signal generation

**5.15.3 Control of SVD circuit**

Table 5.15.3.1 shows the SVD circuit control bits.

Table 5.15.3.1 SVD circuit control bits

Address	Bit	Name	Function	1	0	SR	R/W	Comment																									
00FF12	D7	–	–	–	–	–		Constrant "0" when being read																									
	D6	–	–	–	–	–																											
	D5	SVDSP	SVD auto-sampling control	On	Off	0	R/W	These registers are reset to "0" when																									
	D4	SVDON	SVD continuous sampling control/status	Busy On	Ready Off	1→0*1 0	R/W	SLP instruction is executed.																									
	D3	SVD3	SVD detection level	<table border="1"> <tr> <th>SVD3</th> <th>SVD2</th> <th>SVD1</th> <th>SVD0</th> <th>Detection level</th> </tr> <tr> <td>1</td> <td>1</td> <td>1</td> <td>1</td> <td>Level 15</td> </tr> <tr> <td>1</td> <td>1</td> <td>1</td> <td>0</td> <td>Level 14</td> </tr> <tr> <td>⋮</td> <td>⋮</td> <td>⋮</td> <td>⋮</td> <td>⋮</td> </tr> <tr> <td>0</td> <td>0</td> <td>0</td> <td>0</td> <td>Level 0</td> </tr> </table>	SVD3	SVD2	SVD1	SVD0	Detection level	1	1	1	1	Level 15	1	1	1	0	Level 14	⋮	⋮	⋮	⋮	⋮	0	0	0	0	Level 0	–	–	X	R
SVD3	SVD2	SVD1			SVD0	Detection level																											
1	1	1			1	Level 15																											
1	1	1			0	Level 14																											
⋮	⋮	⋮			⋮	⋮																											
0	0	0	0	Level 0																													
D2	SVD2	–	–	–	–	X	R																										
D1	SVD1	–	–	–	–	X	R																										
⋮	⋮	–	–	–	–	–	–																										
D0	SVD0	–	–	–	–	X	R																										

\*1 After initial reset, this status is set "1" until conclusion of hardware first sampling.

\*2 Initial values are set according to the supply voltage detected at first sampling by hardware. Until conclusion of first sampling, SVD0–SVD3 data are undefined.

**SVDON: 00FF12H•D4**

Controls the turning ON/OFF of the continuous sampling mode.

When "1" is written: Continuous sampling ON  
When "0" is written: Continuous sampling OFF

When "1" is read: BUSY  
When "0" is read: READY

The continuous sampling mode goes ON when "1" is written to SVDON and goes OFF, when "0" is written.

In the ON status, sampling of the supply voltage is done continuously in 7.8 msec cycles and the detection result is latched to SVD0–SVD3.

SVDON can be read, and "1" indicates SVD circuit operation (BUSY) and "0" indicates standby (READY).

At initial reset and in the SLEEP status, SVDON is set to "0" (continuous sampling OFF/READY).

**SVDSP: 00FF12H•D5**

Controls the turning ON/OFF of the 1/4 Hz auto-sampling mode.

When "1" is written: Auto-sampling ON  
When "0" is written: Auto-sampling OFF  
Reading: Valid

The 1/4 Hz auto-sampling mode goes ON when "1" is written to SVDSP and goes OFF, when "0" is written.

In the ON status, sampling is done in every 4 seconds and "1" is read from SVDON during the actual sampling period (7.8 msec).

At initial reset and in the SLEEP status, SVDSP is set to "0" (auto-sampling OFF).

**SVD0–SVD3: 00FF12H•D0–D3**

The detection result of the SVD is set.

The reading data correspond to the detection levels as shown in Table 5.15.3.2 and the data is maintained until the next sampling.

Table 5.15.3.2 Supply voltage detection results

SVD3	SVD2	SVD1	SVD0	Detection level
1	1	1	1	Level 15
1	1	1	0	Level 14
1	1	0	1	Level 13
1	1	0	0	Level 12
1	0	1	1	Level 11
1	0	1	0	Level 10
1	0	0	1	Level 9
1	0	0	0	Level 8
0	1	1	1	Level 7
0	1	1	0	Level 6
0	1	0	1	Level 5
0	1	0	0	Level 4
0	0	1	1	Level 3
0	0	1	0	Level 2
0	0	0	1	Level 1
0	0	0	0	Level 0

For the correspondence between the detection level and the supply voltage, see "7 ELECTRICAL CHARACTERISTICS".

The initial value at initial reset is set according to the supply voltage detected at first sampling by hardware. Data of this bit is undefined until this sampling is completed.

**5.15.4 Programming notes**

- (1) To reduce current consumption, turn the SVD circuit OFF (SVDON = SVDSP = "0") when it is not necessary.
- (2) When executing an SLP instruction while the SVD circuit is operating, the stop operation of the OSC1 oscillation circuit is kept waiting until the sampling is completed. The two bits of SVDON and SVDSP are automatically reset to "0" by hardware while waiting for completion of sampling.

### 5.16 Interrupt and Standby Status

**Types of interrupts**

Six systems and 15 types of interrupts have been provided for the E0C883xx.

- |  |
|--|
| <p><b>External interrupt</b></p> <ul style="list-style-type: none"> <li>•K00–K07 input interrupt (2 types)</li> <li>•K10 and K11 input interrupt (1 type)</li> </ul> <p><b>Internal interrupt</b></p> <ul style="list-style-type: none"> <li>•Clock timer interrupt (4 types)</li> <li>•Stopwatch timer interrupt (3 types)</li> <li>•Programmable timer interrupt (2 types)</li> <li>•Serial interface interrupt (3 types)</li> </ul> |
|--|

\* K11 is not available in the E0C88308.

An interrupt factor flag that indicates the generation of an interrupt factor and an interrupt enable register that sets enable/disable for interrupt requests have been provided for each interrupt and interrupt generation can be optionally set for each factor.

In addition, an interrupt priority register has been provided for each system of interrupts and the priority of interrupt processing can be set to 3 levels in each system.

Figure 5.16.1 shows the configuration of the interrupt circuit.

Refer to the explanations of the respective peripheral circuits for details on each interrupt.

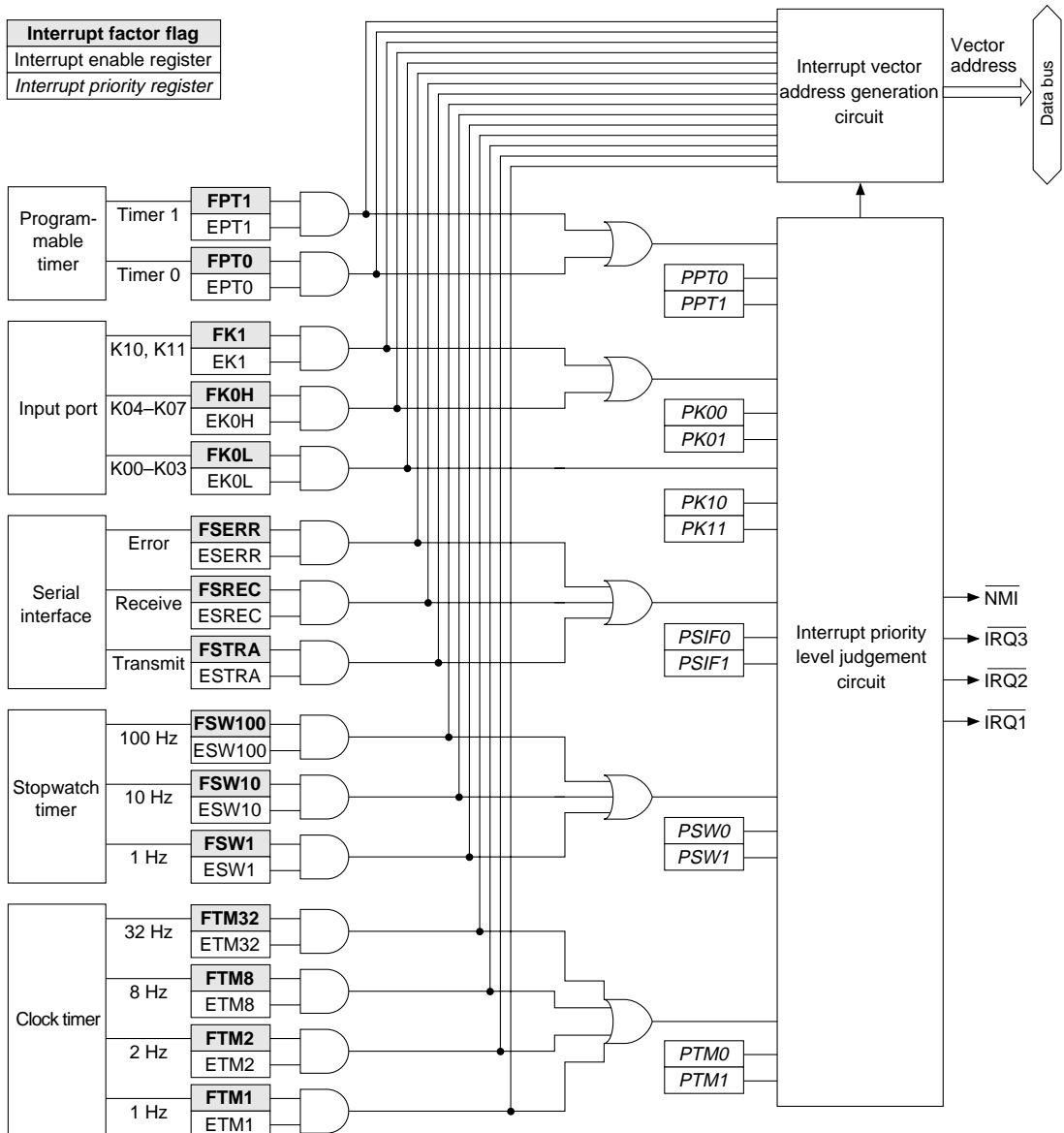

Fig. 5.16.1 Configuration of interrupt circuit

### ■ HALT status

By executing the program's HALT instruction, the E0C883xx shifts to the HALT status.

Since CPU operation stops in the HALT status, power consumption can be reduced with only peripheral circuit operation.

Cancellation of the HALT status is done by initial reset or an optional interrupt request, and the CPU restarts program execution from an exception processing routine.

See the "E0C88 Core CPU Manual" for the HALT status and reactivation sequence.

### ■ SLEEP status

By executing the program's SLP instruction, the E0C883xx shifts to the SLEEP status.

Since the operation of the CPU and peripheral circuits stop completely in the SLEEP status, power consumption can be reduced even more than in the HALT status. Cancellation of the SLEEP status is done by initial reset or an input interrupt from the input port. The CPU reactivates after waiting 8,192/fOSC1 seconds of oscillation stabilization time. At this time, the CPU restarts program execution from an exception processing routine (input interrupt routine).

- Notes:*
- Since oscillation is unstable for a short time after reactivation from the SLEEP status, the wait time is not always 250 msec even when using the 32.768 kHz crystal oscillator for the OSC1 oscillation circuit.
  - The CE terminal status in HALT or SLEEP mode is different depending on the model. See Note in Section 5.2.2.

## 5.16.1 Interrupt generation conditions

The interrupt factor flags that indicate the generation of their respective interrupt factors are provided for the previously indicated 6 systems and 15 types of interrupts and they will be set to "1" by the generation of a factor.

In addition, interrupt enable registers with a 1 to 1 correspondence to each of the interrupt factor flags are provided. An interrupt is enabled when "1" is written and interrupt is disabled when "0" is written.

The CPU manages the enable/disable of interrupt requests at the interrupt priority level. An interrupt priority register that sets the priority level is provided for each of the interrupts of the 6 systems and the CPU accepts only interrupts above the level that has been indicated with the interrupt flags (I0 and I1).

Consequently, the following three conditions are necessary for the CPU to accept the interrupt.

- (1) The interrupt factor flag has been set to "1" by generation of an interrupt factor.
- (2) The interrupt enable register corresponding to the above has been set to "1".
- (3) The interrupt priority register corresponding to the above has been set to a priority level higher than the interrupt flag (I0 and I1) setting.

The CPU initially samples the interrupt for the first op-code fetch cycle of each instruction. Thereupon, the CPU shifts to the exception processing when the above mentioned conditions have been established. See the "E0C88 Core CPU Manual" for the exception processing sequence.

## 5.16.2 Interrupt factor flag

Table 5.16.2.1 shows the correspondence between the factors generating an interrupt and the interrupt factor flags.

The corresponding interrupt factor flags are set to "1" by generation of the respective interrupt factors. The corresponding interrupt factor can be confirmed by reading the flags through software.

Table 5.16.2.1 Interrupt factors

Interrupt factor	Interrupt factor flag
Programmable timer 1 underflow	FPT1 (00FF25 D7)
Programmable timer 0 underflow	FPT0 (00FF25 D6)
Non matching of the K10 and K11 inputs and the input comparison registers KCP10 and KCP11	FK1 (00FF25 D5)
Non matching of the K04–K07 inputs and the input comparison registers KCP04–KCP07	FK0H (00FF25 D4)
Non matching of the K00–K03 inputs and the input comparison registers KCP00–KCP03	FK0L (00FF25 D3)
Serial interface receiving error (in asynchronous mode)	FSERR (00FF25 D2)
Serial interface receiving completion	FSREC (00FF25 D1)
Serial interface transmitting completion	FSTRA (00FF25 D0)
Falling edge of the stopwatch timer 100 Hz signal	FSW100 (00FF24 D6)
Falling edge of the stopwatch timer 10 Hz signal	FSW10 (00FF24 D5)
Falling edge of the stopwatch timer 1 Hz signal	FSW1 (00FF24 D4)
Rising edge of the clock timer 32 Hz signal	FTM32 (00FF24 D3)
Rising edge of the clock timer 8 Hz signal	FTM8 (00FF24 D2)
Rising edge of the clock timer 2 Hz signal	FTM2 (00FF24 D1)
Rising edge of the clock timer 1 Hz signal	FTM1 (00FF24 D0)

Interrupt factor flag that has been set to "1" is reset to "0" by writing "1".

At initial reset, the interrupt factor flags are reset to "0".

*Note: When executing the RETE instruction without resetting the interrupt factor flag after an interrupt has been generated, the same interrupt will be generated. Consequently, the interrupt factor flag corresponding to that routine must be reset (writing "1") in the interrupt processing routine.*

### 5.16.3 Interrupt enable register

The interrupt enable register has a 1 to 1 correspondence with each interrupt factor flag and enable/disable of interrupt requests can be set.

When "1" is written to the interrupt enable register, an interrupt request is enabled, and is disabled when "0" is written. This register also permits reading, thus making it possible to confirm that a status has been set.

At initial reset, the interrupt enable registers are set to "0" and shifts to the interrupt disable status.

Table 5.16.3.1 shows the correspondence between the interrupt enable registers and the interrupt factor flags.

Table 5.16.3.1 Interrupt enable registers and interrupt factor flags

Interrupt	Interrupt factor flag	Interrupt enable register
Programmable timer 1	FPT1 (00FF25 D7)	EPT1 (00FF23 D7)
Programmable timer 0	FPT0 (00FF25 D6)	EPT0 (00FF23 D6)
K10 and K11 input	FK1 (00FF25 D5)	EK1 (00FF23 D5)
K04–K07 input	FK0H (00FF25 D4)	EK0H (00FF23 D4)
K00–K03 input	FK0L (00FF25 D3)	EK0L (00FF23 D3)
Serial interface receiving error	FSERR (00FF25 D2)	ESERR (00FF23 D2)
Serial interface receiving completion	FSREC (00FF25 D1)	ESREC (00FF23 D1)
Serial interface transmitting completion	FSTRA (00FF25 D0)	ESTRA (00FF23 D0)
Stopwatch timer 100 Hz	FSW100 (00FF24 D6)	ESW100 (00FF22 D6)
Stopwatch timer 10 Hz	FSW10 (00FF24 D5)	ESW10 (00FF22 D5)
Stopwatch timer 1 Hz	FSW1 (00FF24 D4)	ESW1 (00FF22 D4)
Clock timer 32 Hz	FTM32 (00FF24 D3)	ETM32 (00FF22 D3)
Clock timer 8 Hz	FTM8 (00FF24 D2)	ETM8 (00FF22 D2)
Clock timer 2 Hz	FTM2 (00FF24 D1)	ETM2 (00FF22 D1)
Clock timer 1 Hz	FTM1 (00FF24 D0)	ETM1 (00FF22 D0)

Table 5.16.4.1 Interrupt priority register

Interrupt	Interrupt priority register
Programmable timer interrupt	PPT0, PPT1 (00FF21 D2, D3)
K10 and K11 input interrupt	PK10, PK11 (00FF21 D0, D1)
K00–K07 input interrupt	PK00, PK01 (00FF20 D6, D7)
Serial interface interrupt	PSIF0, PSIF1 (00FF20 D4, D5)
Stopwatch timer interrupt	PSW0, PSW1 (00FF20 D2, D3)
Clock timer interrupt	PTM0, PTM1 (00FF20 D0, D1)

### 5.16.4 Interrupt priority register and interrupt priority level

The interrupt priority registers shown in Table 5.16.4.1 are set to each system of interrupts and the interrupt priority levels for the CPU can be set to the optional priority level (0–3). As a result, it is possible to have multiple interrupts that match the system's interrupt processing priority levels.

The interrupt priority level between each system can optionally be set to three levels by the interrupt priority register. However, when more than one system is set to the same priority level, they are processed according to the default priority level.

Table 5.16.4.2 Setting of interrupt priority level

P*1	P*0	Interrupt priority level
1	1	Level 3 (IRQ3)
1	0	Level 2 (IRQ2)
0	1	Level 1 (IRQ1)
0	0	Level 0 (non)



At initial reset, the interrupt priority registers are all set to "0" and each interrupt is set to level 0. Furthermore, the priority levels in each system have been previously decided and they cannot be changed.

The CPU can mask each interrupt by setting the interrupt flags (I0 and I1). The relation between the interrupt priority level of each system and interrupt flags is shown in Table 5.16.4.3, and the CPU accepts only interrupts above the level indicated by the interrupt flags.

The NMI (watchdog timer) that has level 4 priority, is always accepted regardless of the setting of the interrupt flags.

Table 5.16.4.3 Interrupt mask setting of CPU

I1	I0	Acceptable interrupt
1	1	Level 4 (NMI)
1	0	Level 4, Level 3 ( $\overline{\text{IRQ}}_3$ )
0	1	Level 4, Level 3, Level 2 ( $\overline{\text{IRQ}}_2$ )
0	0	Level 4, Level 3, Level 2, Level 1 ( $\overline{\text{IRQ}}_1$ )

After an interrupt has been accepted, the interrupt flags are written to the level of that interrupt. However, interrupt flags after an NMI has been accepted are written to level 3 (I0 = I1 = "1").

Table 5.16.4.4 Interrupt flags after acceptance of interrupt

Accepted interrupt priority level	I1	I0
Level 4 ( $\overline{\text{NMI}}$ )	1	1
Level 3 ( $\overline{\text{IRQ}}_3$ )	1	1
Level 2 ( $\overline{\text{IRQ}}_2$ )	1	0
Level 1 ( $\overline{\text{IRQ}}_1$ )	0	1

The set interrupt flags are reset to their original value on return from the interrupt processing routine. Consequently, multiple interrupts up to 3 levels can be controlled by the initial settings of the interrupt priority registers alone. Additional multiplexing can be realized by rewriting the interrupt flags and interrupt enable register in the interrupt processing routine.

**Note:** Beware. If the interrupt flags have been rewritten (set to lower priority) prior to resetting an interrupt factor flag after an interrupt has been generated, the same interrupt will be generated again.

### 5.16.5 Exception processing vectors

When the CPU accepts an interrupt request, it starts exception processing following completion of the instruction being executed. In exception processing, the following operations branch the program.

- (1) In the minimum mode, the program counter (PC) and system condition flag (SC) are moved to stack and in the maximum mode, the code bank register (CB), PC and SC are moved.
- (2) The branch destination address is read from the exception processing vector corresponding to each exception processing (interrupt) factor and is placed in the PC.

An exception vector is 2 bytes of data in which the top address of each exception (interrupt) processing routine has been stored and the vector addresses correspond to the exception processing factors as shown in Table 5.16.5.1.

Table 5.16.5.1 Vector address and exception processing correspondence

Vector address	Exception processing factor	Priority
000000H	Reset	High ↑
000002H	Zero division	
000004H	Watchdog timer ( $\overline{\text{NMI}}$ )	
000006H	Programmable timer 1 interrupt	
000008H	Programmable timer 0 interrupt	↓ Low
00000AH	K10, K11 input interrupt	
00000CH	K04–K07 input interrupt	
00000EH	K00–K03 input interrupt	
000010H	Serial I/F error interrupt	
000012H	Serial I/F receiving complete interrupt	
000014H	Serial I/F transmitting complete interrupt	
000016H	Stopwatch timer 100 Hz interrupt	
000018H	Stopwatch timer 10 Hz interrupt	
00001AH	Stopwatch timer 1 Hz interrupt	
00001CH	Clock timer 32 Hz interrupt	
00001EH	Clock timer 8 Hz interrupt	
000020H	Clock timer 2 Hz interrupt	
000022H	Clock timer 1 Hz interrupt	
000024H	System reserved (cannot be used)	
000026H	Software interrupt	
:		
0000FEH		

**Note:** An exception processing vector is fixed at 2 bytes, so it cannot specify a branch destination bank address. Consequently, to branch from multiple banks to a common exception processing routine, the top portion of an exception processing routine must be described within the common area (000000H–007FFFH).

5.16.6 Control of interrupt

Table 5.16.6.1 shows the interrupt control bits.

Table 5.16.6.1 Interrupt control bits

Address	Bit	Name	Function	1	0	SR	R/W	Comment	
00FF20	D7	PK01	K00–K07 interrupt priority register	PK01	PK00	0	R/W		
	D6	PK00							
	D5	PSIF1	Serial interface interrupt priority register	PSIF1	PSIF0	0	R/W		
	D4	PSIF0							
	D3	PSW1							
	D2	PSW0	Stopwatch timer interrupt priority register	1	0	Level 3	0		R/W
	D1	PTM1							
D0	PTM0	Clock timer interrupt priority register	0	1	Level 2	0	R/W		
D0	PTM0								
00FF21	D7	–	–	–	–	–	–	Constantly "0" when being read	
	D6	–	–	–	–	–	–		
	D5	–	–	–	–	–	–		–
	D4	–	–	–	–	–	–		–
	D3	PPT1	Programmable timer interrupt priority register	PPT1	PPT0	Priority level	0	R/W	
	D2	PPT0							
D1	PK11	K10 and K11 interrupt priority register	1	0	Level 2	0	R/W		
D0	PK10								
00FF22	D7	–	–	–	–	–	–	"0" when being read	
	D6	ESW100	Stopwatch timer 100 Hz interrupt enable register	Interrupt enable	Interrupt disable	0	R/W		
	D5	ESW10							
	D4	ESW1							
	D3	ETM32							
	D2	ETM8							
	D1	ETM2							
	D0	ETM1							
00FF23	D7	EPT1						Programmable timer 1 interrupt enable register	Interrupt enable
	D6	EPT0							
	D5	EK1	K10 and K11 interrupt enable register						
	D4	EK0H							
	D3	EK0L	K00–K03 interrupt enable register						
	D2	ESERR							
	D1	ESREC							
D0	ESTRA	Serial I/F (transmitting) interrupt enable register							
00FF24	D7	–	–	–	–	–	–	"0" when being read	
	D6	FSW100	Stopwatch timer 100 Hz interrupt factor flag	(R)	(R)	0	R/W		
	D5	FSW10							
	D4	FSW1							
	D3	FTM32							
	D2	FTM8							
	D1	FTM2							
D0	FTM1								
00FF25	D7	FPT1	Programmable timer 1 interrupt factor flag	Interrupt factor is generated	No interrupt factor is generated	0	R/W		
	D6	FPT0							
	D5	FK1	K10 and K11 interrupt factor flag						
	D4	FK0H							
	D3	FK0L	K00–K03 interrupt factor flag						
	D2	FSERR							
	D1	FSREC							
D0	FSTRA	Serial I/F (transmitting) interrupt factor flag							

Refer to the explanations on the respective peripheral circuits for the setting content and control method for each bit.

### 5.16.7 Programming notes

- (1) When executing the RETE instruction without resetting the interrupt factor flag after an interrupt has been generated, the same interrupt will be generated. Consequently, the interrupt factor flag corresponding to that routine must be reset (writing "1") in the interrupt processing routine.
- (2) Beware. If the interrupt flags (I0 and I1) have been rewritten (set to lower priority) prior to resetting an interrupt factor flag after an interrupt has been generated, the same interrupt will be generated again.
- (3) An exception processing vector is fixed at 2 bytes, so it cannot specify a branch destination bank address. Consequently, to branch from multiple banks to a common exception processing routine, the front portion of an exception processing routine must be described within the common area (000000H–007FFFH).
- (4) Do not execute the SLP instruction for 2 msec after a  $\overline{\text{NMI}}$  interrupt has occurred (when  $f_{\text{OSC1}}$  is 32.768 kHz).

## 5.17 Notes for Low Current Consumption

The E0C883xx can turn circuits, which consume a large amount of power, ON or OFF by control registers.

You can reduce power consumption by creating a program that operates the minimum necessary circuits using these control registers.

Next, which circuit systems' operation can be controlled and their control registers (instructions) are explained. You should refer to these when programming.

See Chapter 7, "ELECTRICAL CHARACTERISTICS" for the current consumption.

Table 5.17.1 Circuit systems and control registers

Circuit type	Control register (Instruction)	Status at time of initial resetting
CPU	HALT and SLP instructions	Operation status
Oscillation circuit	CLKCHG, OSCC	OSC1 clock (CLKCHG = "0") OSC3 oscillation OFF (OSCC = "0")
Operating mode	VDC0, VDC1	Normal mode (VDC0 = VDC1 = "0")
LCD controller	LCDC0, LCDC1	Drive OFF (LCDC0 = LCDC1 = "0")
SVD circuit	SVDON, SVDSP	OFF status (SVDON = SVDSP = "0")
Analog comparator	CMP0ON, CMP1ON	OFF status (CMP0ON = CMP1ON = "0")

# 6 BASIC EXTERNAL WIRING DIAGRAM

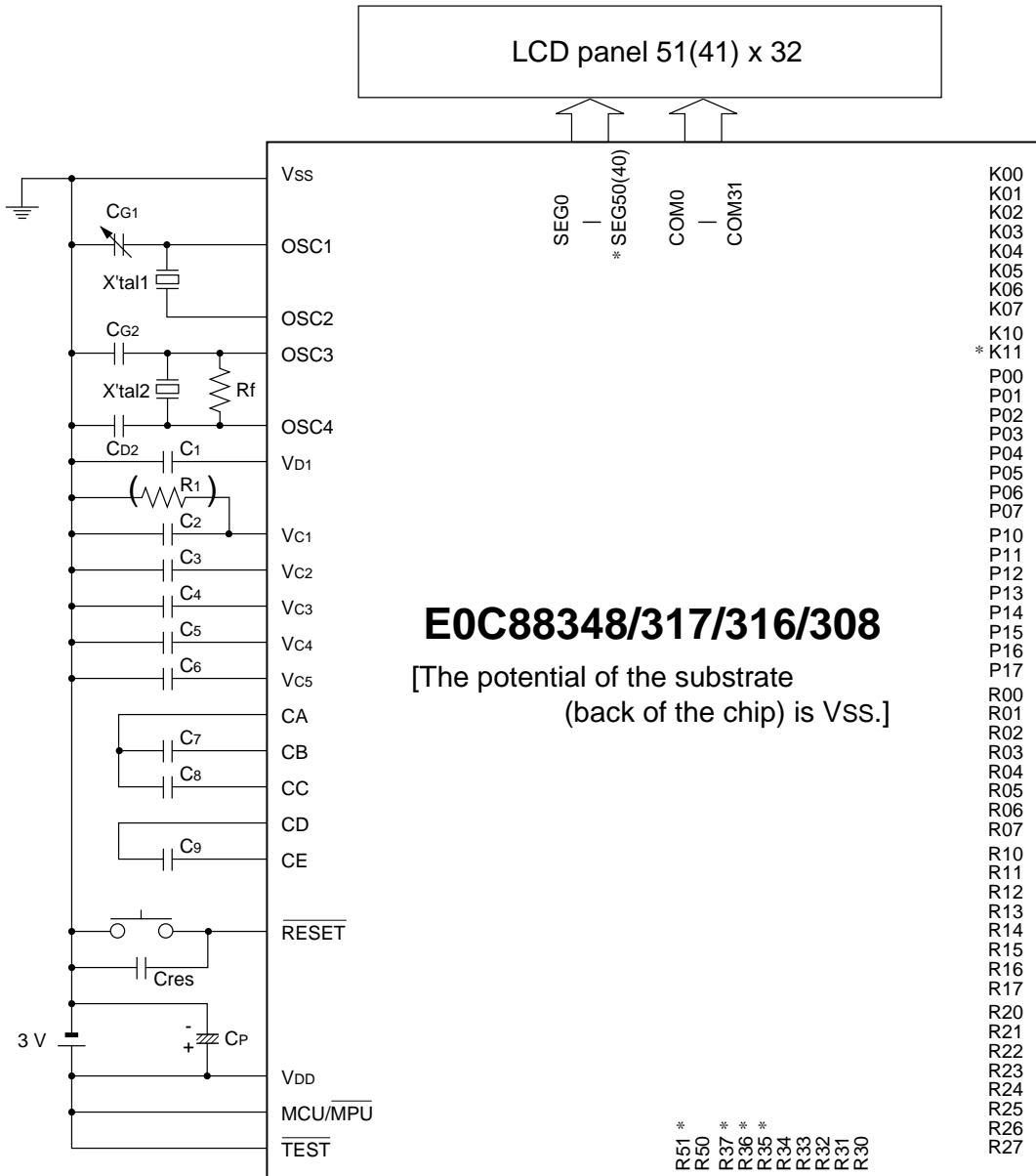

**Recommended values for external parts**

Symbol	Name	Recommended value
X'tal1	Crystal oscillator	32.768 kHz, CI (Max.) = 35 kΩ
X'tal2	Crystal oscillator	4.9152 MHz
Rf	Feedback resistor	1 MΩ
CG1	Trimmer capacitor	5–25 pF
CG2	Gate capacitor	15 pF
Cd2	Drain capacitor	15 pF
C1	Capacitor between Vss and VD1	0.1 μF
C2	Capacitor between Vss and VC1	0.1 μF

Symbol	Name	Recommended value
C3	Capacitor between Vss and VC2	0.1 μF
C4	Capacitor between Vss and VC3	0.1 μF
C5	Capacitor between Vss and VC4	0.1 μF
C6	Capacitor between Vss and VC5	0.1 μF
C7–C9	Booster capacitors	0.1 μF
CP	Capacitor for power supply	3.3 μF
Cres	Capacitor for RESET terminal	0.47 μF
R1	Load resistor between Vss and VC1	100 kΩ (It is needed when driving an LCD panel that constitutes a heavy load.)

# 7 ELECTRICAL CHARACTERISTICS

## 7.1 Absolute Maximum Rating

(V <sub>SS</sub> = 0 V)					
Item	Symbol	Condition	Rated value	Unit	Note
Power voltage	V <sub>DD</sub>		-0.3 to +7.0	V	
Liquid crystal power voltage	V <sub>C5</sub>		-0.3 to +7.0	V	
Input voltage	V <sub>I</sub>		-0.3 to V <sub>DD</sub> + 0.3	V	
Output voltage	V <sub>O</sub>		-0.3 to V <sub>DD</sub> + 0.3	V	1
High level output current	I <sub>OH</sub>	1 terminal	-5	mA	
		Total of all terminals	-20	mA	
Low level output current	I <sub>OL</sub>	1 terminal	5	mA	
		Total of all terminals	20	mA	
Permitted loss	P <sub>D</sub>		200	mW	2
Operating temperature	T <sub>opr</sub>		-40 to +85	°C	
Storage temperature	T <sub>stg</sub>		-65 to +150	°C	

Note) 1 Case that to Nch open drain output by the mask option is included.

2 In case of plastic package.

## 7.2 Recommended Operating Conditions

(V<sub>SS</sub> = 0 V, T<sub>a</sub> = -40 to 85°C)

Item	Symbol	Condition	Min.	Typ.	Max.	Unit	Note
Operating power voltage (Normal mode)	VDD		2.4		5.5	V	
Operating power voltage (Low power mode)	VDD		1.8		3.5	V	
Operating power voltage (High speed mode)	VDD		3.5		5.5	V	
Operating frequency (Normal mode)	fOSC1	VDD = 2.4 to 5.5 V	30.000	32.768	50.000	kHz	1
	fOSC3		0.03		4.2		
Operating frequency (Low power mode)	fOSC1	VDD = 1.8 to 3.5 V	30.000	32.768	50.000	kHz	1
Operating frequency (High speed mode)	fOSC1	VDD = 3.5 to 5.5 V	30.000	32.768	50.000	kHz	1
	fOSC3		0.03		8.2		
Liquid crystal power voltage	VC5	VC5 ≥ VC4 ≥ VC3 ≥ VC2 ≥ VC1 ≥ VSS			6.0	V	2
Capacitor between VD1 and VSS	C1			0.1		μF	
Capacitor between VC1 and VSS	C2			0.1		μF	3
Capacitor between VC2 and VSS	C3			0.1		μF	3
Capacitor between VC3 and VSS	C4			0.1		μF	3
Capacitor between VC4 and VSS	C5			0.1		μF	3
Capacitor between VC5 and VSS	C6			0.1		μF	3
Capacitor between CA and CB	C7			0.1		μF	3
Capacitor between CA and CC	C8			0.1		μF	3
Capacitor between CD and CE	C9			0.1		μF	3
Resistor between VC1 and VSS	R1			100		kΩ	4

- Note) 1 When an external clock is input from the OSC1 terminal by the mask option, do not connect anything to the OSC2 terminal, and when an external clock is input from the OSC3 terminal, do not connect to the OSC4 terminal.
- 2 When external power supply is selected by the mask option.
- 3 When LCD drive power is not used, the capacitor is not necessary.  
In this case, do not connect anything to VC1 to VC5 and CA to CE terminals.
- 4 It is necessary when the panel load is large and for 1/32 duty driving.  
The resistance value should be decided by connecting it to the actual panel to be used.
- 5 When CR oscillation is selected to OSC3, the maximum frequency is limited to 3 MHz.
- 6 When CR oscillation is selected to OSC3, the maximum frequency is limited to 4 MHz.

### 7.3 DC Characteristics

Unless otherwise specified:  $V_{DD} = 1.8$  to  $5.5$  V,  $V_{SS} = 0$  V,  $T_a = -40$  to  $85^\circ\text{C}$

Item	Symbol	Condition	Min.	Typ.	Max.	Unit	Note
High level input voltage (1)	$V_{IH1}$	$K_{XX}, P_{XX}, \overline{MCU/MPU}$	$0.8V_{DD}$		$V_{DD}$	V	
Low level input voltage (1)	$V_{IL1}$	$K_{XX}, P_{XX}, \overline{MCU/MPU}$	0		$0.2V_{DD}$	V	
High level input voltage (2) (Normal mode)	$V_{IH2}$	OSC1, OSC3	1.6		$V_{DD}$	V	1
High level input voltage (2) (Low power mode)	$V_{IH2}$	OSC1	1.0		$V_{DD}$	V	1
High level input voltage (2) (High speed mode)	$V_{IH2}$	OSC1, OSC3	2.4		$V_{DD}$	V	1
Low level input voltage (2) (Normal mode)	$V_{IL2}$	OSC1, OSC3	0		0.6	V	1
Low level input voltage (2) (Low power mode)	$V_{IL2}$	OSC1	0		0.3	V	1
Low level input voltage (2) (High speed mode)	$V_{IL2}$	OSC1, OSC3	0		0.9	V	1
High level schmitt input voltage	$V_{T+}$	$\overline{RESET}$	$0.5V_{DD}$		$0.9V_{DD}$	V	
Low level schmitt input voltage	$V_{T-}$	$RESET$	$0.1V_{DD}$		$0.5V_{DD}$	V	
High level output current	$I_{OH}$	$P_{XX}, R_{XX}, V_{OH} = 0.9 V_{DD}$			-0.5	mA	
Low level output current	$I_{OL}$	$P_{XX}, R_{XX}, V_{OL} = 0.1 V_{DD}$	0.5			mA	
Input leak current	$I_{LI}$	$K_{XX}, P_{XX}, \overline{RESET}, \overline{MCU/MPU}$	-1		1	$\mu\text{A}$	
Output leak current	$I_{LO}$	$P_{XX}, R_{XX}$	-1		1	$\mu\text{A}$	
Input pull-up resistance	$R_{IN}$	$K_{XX}, P_{XX}, \overline{RESET}, \overline{MCU/MPU}$	100		500	$\text{k}\Omega$	2
Input terminal capacitance	$C_{IN}$	$K_{XX}, P_{XX}$ $V_{IN} = 0$ V, $f = 1$ MHz, $T_a = 25^\circ\text{C}$			15	pF	
Segment/Common output current	$I_{SEGH}$	$SEG_{XX}, COM_{XX}, V_{SEGH} = V_{C5} - 0.1$ V			-5	$\mu\text{A}$	
	$I_{SEGL}$	$SEG_{XX}, COM_{XX}, V_{SEGL} = 0.1$ V	5			$\mu\text{A}$	

- Note) 1 When external clock is selected by mask option.  
 2 When addition of pull-up resistor is selected by mask option.

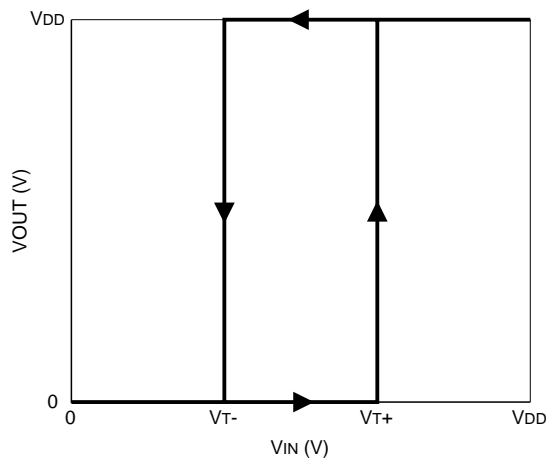



## 7.4 Analog Circuit Characteristics

### ■ LCD drive circuit

The Typ. values of the LCD drive voltage shown in the following table shift in difference of panel load (panel size, drive duty, display segment number). Therefore, these should be evaluated by connecting to the actual panel to be used. Moreover, if the display is uneven with a large panel load, connect a resistor (R1) between the VSS and VC1 terminal. (It is necessary in 1/32 duty driving.)

Unless otherwise specified:  $V_{DD} = V_{C2}$  (LCX = FH) +0.1 to 5.5 V,  $V_{SS} = 0$  V,  $T_a = 25^\circ\text{C}$ ,

$C_1 = C_2 = C_3 = C_4 = C_5 = C_6 = C_7 = C_8 = C_9 = 0.1 \mu\text{F}$

Item	Symbol	Condition	Min.	Typ.	Max.	Unit	Note	
LCD drive voltage	VC1	*1	0.18Vcs		0.22Vcs	V		
	VC2	*2	0.39Vcs		0.43Vcs	V		
	VC3	*3	0.59Vcs		0.63Vcs	V		
	VC4	*4		0.80Vcs		0.84Vcs	V	
	VC5 TYPE A (4.5V)	*5	LCX = 0H	Typ×0.94	3.89	Typ×1.06	V	
			LCX = 1H		3.96		V	
			LCX = 2H		4.04		V	
			LCX = 3H		4.11		V	
			LCX = 4H		4.18		V	
			LCX = 5H		4.26		V	
			LCX = 6H		4.34		V	
			LCX = 7H		4.42		V	
			LCX = 8H		4.50		V	
			LCX = 9H		4.58		V	
			LCX = AH		4.66		V	
			LCX = BH		4.74		V	
			LCX = CH		4.82		V	
			LCX = DH		4.90		V	
			LCX = EH		4.99		V	
			LCX = FH		5.08		V	
			VC5 TYPE B (5.5V)		*5		LCX = 0H	Typ×0.94
	LCX = 1H	4.83		V				
	LCX = 2H	4.92		V				
	LCX = 3H	5.02		V				
	LCX = 4H	5.11		V				
	LCX = 5H	5.21		V				
	LCX = 6H	5.30		V				
	LCX = 7H	5.40		V				
	LCX = 8H	5.50		V				
LCX = 9H	5.60	V						
LCX = AH	5.70	V						
LCX = BH	5.81	V						
LCX = CH	5.93	V						
LCX = DH	6.05	V						
LCX = EH	6.17	V						
LCX = FH	6.29	V						

\*1 Connects 1 MΩ load resistor between VSS and VC1. (without panel load)

\*2 Connects 1 MΩ load resistor between VSS and VC2. (without panel load)

\*3 Connects 1 MΩ load resistor between VSS and VC3. (without panel load)

\*4 Connects 1 MΩ load resistor between VSS and VC4. (without panel load)

\*5 Connects 1 MΩ load resistor between VSS and VC5. (without panel load)

## 7 ELECTRICAL CHARACTERISTICS

### ■ SVD circuit

Unless otherwise specified:  $V_{DD} = 1.8$  to  $5.5$  V,  $V_{SS} = 0$  V,  $T_a = 25^\circ\text{C}$

Item	Symbol	Condition	Min.	Typ.	Max.	Unit	Note
SVD voltage	VSVD	Level 1 → Level 0	Typ×0.92	1.82	Typ×1.08	V	1
		Level 2 → Level 1		2.00		V	1
		Level 3 → Level 2		2.18		V	1
		Level 4 → Level 3		2.36		V	2
		Level 5 → Level 4		2.54		V	2
		Level 6 → Level 5		2.72		V	2
		Level 7 → Level 6		2.90		V	3
		Level 8 → Level 7		3.08		V	3
		Level 9 → Level 8		3.26		V	3
		Level 10 → Level 9		3.45		V	4
		Level 11 → Level 10		3.65		V	4
		Level 12 → Level 11		3.85		V	4
		Level 13 → Level 12		4.05		V	4
		Level 14 → Level 13		4.25		V	4
		Level 15 → Level 14		4.50		V	4

$V_{SVD}(\text{Level } 0) < V_{SVD}(\text{Level } 1) < V_{SVD}(\text{Level } 2) < V_{SVD}(\text{Level } 3) < V_{SVD}(\text{Level } 4) < V_{SVD}(\text{Level } 5) < V_{SVD}(\text{Level } 6) < V_{SVD}(\text{Level } 7)$

$< V_{SVD}(\text{Level } 8) < V_{SVD}(\text{Level } 9) < V_{SVD}(\text{Level } 10) < V_{SVD}(\text{Level } 11) < V_{SVD}(\text{Level } 12) < V_{SVD}(\text{Level } 13) < V_{SVD}(\text{Level } 14) < V_{SVD}(\text{Level } 15)$

- Note) 1 Low power operating mode only  
 2 Low power operating mode or Normal operating mode only  
 3 Normal operating mode only  
 4 Normal operating mode or High speed operating mode only

### ■ Analog comparator circuit

Unless otherwise specified:  $V_{DD} = 1.8$  to  $5.5$  V,  $V_{SS} = 0$  V,  $T_a = 25^\circ\text{C}$

Item	Symbol	Condition	Min.	Typ.	Max.	Unit	Note
Analog comparator operating voltage input range	VCMP	Non-inverted input (CMPP)	0.7		$V_{DD} - 0.7$	V	1
	VCMM	Inverted input (CMPM)	0.7		$V_{DD} - 0.7$	V	1
Analog comparator offset voltage	VCMOF	VCMP = 0.7 V to $V_{DD} - 0.7$ V VCMM = 0.7 V to $V_{DD} - 0.7$ V			20	mV	1
Analog comparator stability time	tCMP1				1	mS	2
Analog comparator response time	tCMP2	VCMP = 0.7 V to $V_{DD} - 0.7$ V VCMM = 0.7 V to $V_{DD} - 0.7$ V			2	mS	1
		VCMP = VCMM ± 0.025 V					3

- Note) 1 When "without pull-up resistor" (comparator input terminal) is selected by mask option.  
 2 Stability time is the time from turning the circuit ON until the circuit is stabilized.  
 3 Response time is the time that the output result responds to the input signal.

## 7.5 Power Current Consumption

Unless otherwise specified: V<sub>DD</sub> = Within the operating voltage in each operating mode, V<sub>SS</sub> = 0 V, T<sub>a</sub> = 25°C, OSC1 = 32.768 kHz crystal oscillation, C<sub>G</sub> = 25pF, OSC3 = External clock input, Non heavy load protection mode, C1 = C2 = C3 = C4 = C5 = C6 = C7 = C8 = C9 = 0.1 μF, No panel load

Item	Symbol	Condition	Min.	Typ.	Max.	Unit	Note
Power current (Normal mode)	IDD1	In SLEEP status *1		0.3	1	μA	
	IDD2	In HALT status *2		2	5	μA	
	IDD3	CPU is in operating (32.768 kHz) *3		14	18	μA	
	IDD4	CPU is in operating (1 MHz) *4		0.45	0.60	mA	
	IDD5	CPU is in operating (OSC3 = 1 MHz, Crystal) *5		0.55	1.0	mA	
	IDD6	CPU is in operating (OSC3 = 1 MHz, Ceramic) *5		0.55	1.0	mA	
	IDD7	CPU is in operating (OSC3 = CR, R = 100 kΩ) *5		1.1	1.7	mA	
	IHVL	In heavy load protection mode		25	50	μA	1
Power current (Low power mode)	IDD1	In SLEEP status *1		0.2	1	μA	
	IDD2	In HALT status *2		1	5	μA	
	IDD3	CPU is in operating (32.768 kHz) *3		8	12	μA	
	IHVL	In heavy load protection mode		15	30	μA	1
Power current (High speed mode)	IDD1	In SLEEP status *1		1	3	μA	
	IDD2	In HALT status *2		5	10	μA	
	IDD3	CPU is in operating (32.768 kHz) *3		24	30	μA	
	IDD4	CPU is in operating (1 MHz) *4		0.70	1.00	mA	
	IDD5	CPU is in operating (OSC3 = 1 MHz, Crystal) *5		1.2	2.5	mA	
	IDD6	CPU is in operating (OSC3 = 1 MHz, Ceramic) *5		1.2	2.5	mA	
	IDD7	CPU is in operating (OSC3 = CR, R = 100 kΩ) *5		3.4	4.7	mA	
	IHVL	In heavy load protection mode		35	70	μA	1
LCD drive circuit current	ILCDN			2.5	5	μA	
	ILCDH	In heavy load protection mode		15	30	μA	1
SVD circuit current	ISVDN	V <sub>DD</sub> = 3.0 V		30	60	μA	2
	ISVDH	In heavy load protection mode		25	75	μA	1
Analog comparator circuit current	ICMP1	CMPXDT = "1"		40	100	μA	
	ICMP2	CMPXDT = "0"		4	10	μA	
OSC1 CR oscillation current	ICR1			20	50	μA	3

\*1 OSC1: Stop, OSC3: Stop, CPU, ROM, RAM: SLEEP status, Clock timer: Stop, Others: Stop status

\*2 OSC1: Oscillating, OSC3: Stop, CPU, ROM, RAM: HALT status, Clock timer: Operating, Others: Stop status

\*3 OSC1: Oscillating, OSC3: Stop, CPU, ROM, RAM: Operating in 32.768 kHz, Clock timer: Operating, Others: Stop status

\*4 OSC1: Oscillating, OSC3: External, CPU, ROM, RAM: Operating in 1 MHz, Clock timer: Operating, Others: Stop status

\*5 SC1: Oscillating, OSC3: Oscillating, CPU, ROM, RAM: Operating in 1 MHz, Clock timer: Operating, Others: Stop status

Note) 1 It is the value of current which flows in the heavy load protection circuit when in the heavy load protection mode (OSC3 ON or buzzer ON).

2 The value in  $x$  V can be found by the following expression: ISVDN (V<sub>DD</sub> =  $x$  V) = ( $x$  × 20) - 30 (Typ. value),  
ISVDN (V<sub>DD</sub> =  $x$  V) = ( $x$  × 30) - 30 (Max. value)

3 When OSC1 CR oscillation circuit is selected by the mask option.

## 7.6 AC Characteristics

### ■ External memory access

#### • Read cycle (Normal operating mode)

Condition:  $V_{DD} = 2.4$  to  $5.5$  V,  $V_{SS} = 0$  V,  $T_a = -40$  to  $85^\circ\text{C}$ ,  $V_{IH1} = 0.8V_{DD}$ ,  $V_{IL1} = 0.2V_{DD}$ ,  $V_{IH2} = 1.6$  V,  $V_{IL2} = 0.6$  V,  $V_{OH} = 0.8V_{DD}$ ,  $V_{OL} = 0.2V_{DD}$ ,  $C_L = 100$  pF (load capacitance)

Item	Symbol	Min.	Typ.	Max.	Unit	Note
Address set-up time in read cycle	tras	$t_c + t_l - 100 + n \cdot t_c / 2$			nS	1
Address hold time in read cycle	trah	th-80			nS	
Read signal pulse width	trp	$t_c - 20 + n \cdot t_c / 2$			nS	1
Data input set-up time in read cycle	trds	300			nS	
Data input hold time in read cycle	trdh	0			nS	

Note) 1 Substitute the number of states for wait insertion in n.

#### • Read cycle (High speed operating mode)

Condition:  $V_{DD} = 3.5$  to  $5.5$  V,  $V_{SS} = 0$  V,  $T_a = -40$  to  $85^\circ\text{C}$ ,  $V_{IH1} = 0.8V_{DD}$ ,  $V_{IL1} = 0.2V_{DD}$ ,  $V_{IH2} = 2.4$  V,  $V_{IL2} = 0.9$  V,  $V_{OH} = 0.8V_{DD}$ ,  $V_{OL} = 0.2V_{DD}$ ,  $C_L = 100$  pF (load capacitance)

Item	Symbol	Min.	Typ.	Max.	Unit	Note
Address set-up time in read cycle	tras	$t_c + t_l - 50 + n \cdot t_c / 2$			nS	1
Address hold time in read cycle	trah	th-40			nS	
Read signal pulse width	trp	$t_c - 10 + n \cdot t_c / 2$			nS	1
Data input set-up time in read cycle	trds	150			nS	
Data input hold time in read cycle	trdh	0			nS	

Note) 1 Substitute the number of states for wait insertion in n.

#### • Read cycle (Low power operating mode)

Condition:  $V_{DD} = 1.8$  to  $3.5$  V,  $V_{SS} = 0$  V,  $T_a = -40$  to  $85^\circ\text{C}$ ,  $V_{IH1} = 0.8V_{DD}$ ,  $V_{IL1} = 0.2V_{DD}$ ,  $V_{IH2} = 1.0$  V,  $V_{IL2} = 0.3$  V,  $V_{OH} = 0.8V_{DD}$ ,  $V_{OL} = 0.2V_{DD}$ ,  $C_L = 100$  pF (load capacitance)

Item	Symbol	Min.	Typ.	Max.	Unit	Note
Address set-up time in read cycle	tras	15			$\mu\text{S}$	
Address hold time in read cycle	trah	5			$\mu\text{S}$	
Read signal pulse width	trp	10			$\mu\text{S}$	
Data input set-up time in read cycle	trds	10			$\mu\text{S}$	
Data input hold time in read cycle	trdh	0			$\mu\text{S}$	

#### • Write cycle (Normal operating mode)

Condition:  $V_{DD} = 2.4$  to  $5.5$  V,  $V_{SS} = 0$  V,  $T_a = -40$  to  $85^\circ\text{C}$ ,  $V_{IH1} = 0.8V_{DD}$ ,  $V_{IL1} = 0.2V_{DD}$ ,  $V_{IH2} = 1.6$  V,  $V_{IL2} = 0.6$  V,  $V_{OH} = 0.8V_{DD}$ ,  $V_{OL} = 0.2V_{DD}$ ,  $C_L = 100$  pF (load capacitance)

Item	Symbol	Min.	Typ.	Max.	Unit	Note
Address set-up time in write cycle	twas	$t_c - 180$			nS	
Address hold time in write cycle	twah	th-80			nS	
Write signal pulse width	twp	$t_l - 40 + n \cdot t_c / 2$			nS	1
Data output set-up time in write cycle	twds	$t_c - 180 + n \cdot t_c / 2$			nS	1
Data output hold time in write cycle	twdh	th-80		th+80	nS	

Note) 1 Substitute the number of states for wait insertion in n.

### • Write cycle (High speed operating mode)

Condition:  $V_{DD} = 3.5$  to  $5.5$  V,  $V_{SS} = 0$  V,  $T_a = -40$  to  $85^\circ\text{C}$ ,  $V_{IH1} = 0.8V_{DD}$ ,  $V_{IL1} = 0.2V_{DD}$ ,  $V_{IH2} = 2.4$  V,  $V_{IL2} = 0.9$  V,  $V_{OH} = 0.8V_{DD}$ ,  $V_{OL} = 0.2V_{DD}$ ,  $C_L = 100$  pF (load capacitance)

Item	Symbol	Min.	Typ.	Max.	Unit	Note
Address set-up time in write cycle	t <sub>was</sub>	t <sub>c</sub> -90			nS	
Address hold time in write cycle	t <sub>wah</sub>	t <sub>h</sub> -40			nS	
Write signal pulse width	t <sub>wp</sub>	t <sub>l</sub> -20+n•t <sub>c</sub> /2			nS	1
Data output set-up time in write cycle	t <sub>wds</sub>	t <sub>c</sub> -90+n•t <sub>c</sub> /2			nS	1
Data output hold time in write cycle	t <sub>wdh</sub>	t <sub>h</sub> -40		t <sub>h</sub> +40	nS	

Note) 1 Substitute the number of states for wait insertion in n.

### • Write cycle (Low power operating mode)

Condition:  $V_{DD} = 1.8$  to  $3.5$  V,  $V_{SS} = 0$  V,  $T_a = -40$  to  $85^\circ\text{C}$ ,  $V_{IH1} = 0.8V_{DD}$ ,  $V_{IL1} = 0.2V_{DD}$ ,  $V_{IH2} = 1.0$  V,  $V_{IL2} = 0.3$  V,  $V_{OH} = 0.8V_{DD}$ ,  $V_{OL} = 0.2V_{DD}$ ,  $C_L = 100$  pF (load capacitance)

Item	Symbol	Min.	Typ.	Max.	Unit	Note
Address set-up time in write cycle	t <sub>was</sub>	10			μS	
Address hold time in write cycle	t <sub>wah</sub>	5			μS	
Write signal pulse width	t <sub>wp</sub>	5			μS	
Data output set-up time in write cycle	t <sub>wds</sub>	10			μS	
Data output hold time in write cycle	t <sub>wdh</sub>	5		20	μS	

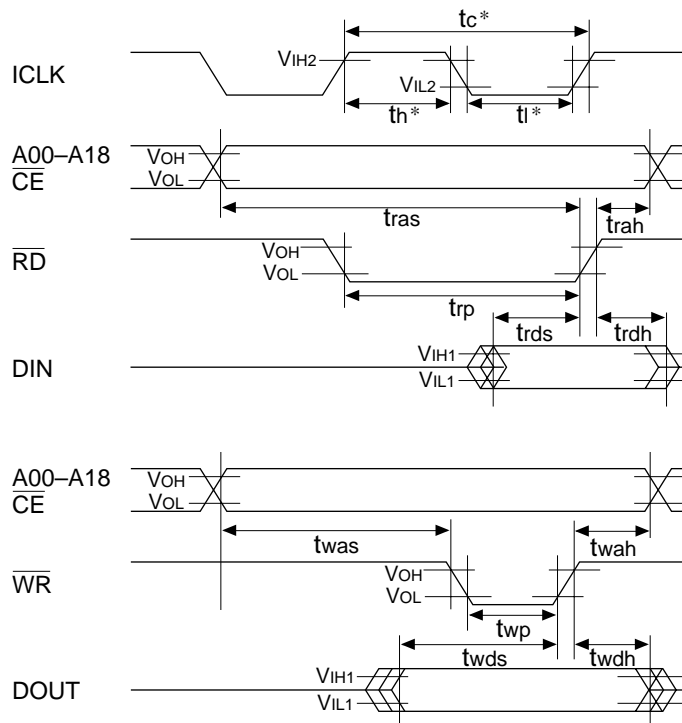

\* In the case of crystal oscillation and ceramic oscillation:  $t_h = 0.5t_c \pm 0.05t_c$ ,  $t_l = t_c - t_h$  ( $1/t_c$ : oscillation frequency)

\* In the case of CR oscillation:  $t_h = 0.5t_c \pm 0.10t_c$ ,  $t_l = t_c - t_h$  ( $1/t_c$ : oscillation frequency)

## 7 ELECTRICAL CHARACTERISTICS

### ■ Serial interface

#### • Clock synchronous master mode (Normal operating mode)

Condition:  $V_{DD} = 2.4$  to  $5.5$  V,  $V_{SS} = 0$  V,  $T_a = -40$  to  $85^\circ\text{C}$ ,  $V_{IH1} = 0.8V_{DD}$ ,  $V_{IL1} = 0.2V_{DD}$ ,  $V_{OH} = 0.8V_{DD}$ ,  $V_{OL} = 0.2V_{DD}$

Item	Symbol	Min.	Typ.	Max.	Unit	Note
Transmitting data output delay time	t <sub>smd</sub>			200	nS	
Receiving data input set-up time	t <sub>sms</sub>	500			nS	
Receiving data input hold time	t <sub>smh</sub>	200			nS	

#### • Clock synchronous master mode (High speed operating mode)

Condition:  $V_{DD} = 3.5$  to  $5.5$  V,  $V_{SS} = 0$  V,  $T_a = -40$  to  $85^\circ\text{C}$ ,  $V_{IH1} = 0.8V_{DD}$ ,  $V_{IL1} = 0.2V_{DD}$ ,  $V_{OH} = 0.8V_{DD}$ ,  $V_{OL} = 0.2V_{DD}$

Item	Symbol	Min.	Typ.	Max.	Unit	Note
Transmitting data output delay time	t <sub>smd</sub>			100	nS	
Receiving data input set-up time	t <sub>sms</sub>	250			nS	
Receiving data input hold time	t <sub>smh</sub>	100			nS	

#### • Clock synchronous master mode (Low power operating mode)

Condition:  $V_{DD} = 1.8$  to  $3.5$  V,  $V_{SS} = 0$  V,  $T_a = -40$  to  $85^\circ\text{C}$ ,  $V_{IH1} = 0.8V_{DD}$ ,  $V_{IL1} = 0.2V_{DD}$ ,  $V_{OH} = 0.8V_{DD}$ ,  $V_{OL} = 0.2V_{DD}$

Item	Symbol	Min.	Typ.	Max.	Unit	Note
Transmitting data output delay time	t <sub>smd</sub>			5	μS	
Receiving data input set-up time	t <sub>sms</sub>	10			μS	
Receiving data input hold time	t <sub>smh</sub>	5			μS	

#### • Clock synchronous slave mode (Normal operating mode)

Condition:  $V_{DD} = 2.4$  to  $5.5$  V,  $V_{SS} = 0$  V,  $T_a = -40$  to  $85^\circ\text{C}$ ,  $V_{IH1} = 0.8V_{DD}$ ,  $V_{IL1} = 0.2V_{DD}$ ,  $V_{OH} = 0.8V_{DD}$ ,  $V_{OL} = 0.2V_{DD}$

Item	Symbol	Min.	Typ.	Max.	Unit	Note
Transmitting data output delay time	t <sub>ssd</sub>			500	nS	
Receiving data input set-up time	t <sub>sss</sub>	200			nS	
Receiving data input hold time	t <sub>ssh</sub>	200			nS	

#### • Clock synchronous slave mode (High speed operating mode)

Condition:  $V_{DD} = 3.5$  to  $5.5$  V,  $V_{SS} = 0$  V,  $T_a = -40$  to  $85^\circ\text{C}$ ,  $V_{IH1} = 0.8V_{DD}$ ,  $V_{IL1} = 0.2V_{DD}$ ,  $V_{OH} = 0.8V_{DD}$ ,  $V_{OL} = 0.2V_{DD}$

Item	Symbol	Min.	Typ.	Max.	Unit	Note
Transmitting data output delay time	t <sub>ssd</sub>			250	nS	
Receiving data input set-up time	t <sub>sss</sub>	100			nS	
Receiving data input hold time	t <sub>ssh</sub>	100			nS	

#### • Clock synchronous slave mode (Low power operating mode)

Condition:  $V_{DD} = 1.8$  to  $3.5$  V,  $V_{SS} = 0$  V,  $T_a = -40$  to  $85^\circ\text{C}$ ,  $V_{IH1} = 0.8V_{DD}$ ,  $V_{IL1} = 0.2V_{DD}$ ,  $V_{OH} = 0.8V_{DD}$ ,  $V_{OL} = 0.2V_{DD}$

Item	Symbol	Min.	Typ.	Max.	Unit	Note
Transmitting data output delay time	t <sub>ssd</sub>			10	μS	
Receiving data input set-up time	t <sub>sss</sub>	5			μS	
Receiving data input hold time	t <sub>ssh</sub>	5			μS	

• Asynchronous system (All operating mode)

Condition:  $V_{DD} = 1.8$  to  $5.5$  V,  $V_{SS} = 0$  V,  $T_a = -40$  to  $85^\circ\text{C}$

Item	Symbol	Min.	Typ.	Max.	Unit	Note
Start bit detection error time	$t_{sa1}$	0		$t/16$	S	1
Erroneous start bit detection range time	$t_{sa2}$	$9t/16$		$10t/16$	S	2

- Note) 1 Start bit detection error time is a logical delay time from inputting the start bit until internal sampling begins operating.  
(Time as far as AC is excluded.)
- 2 Erroneous start bit detection range time is a logical range to detect whether a LOW level (start bit) has been input again after a start bit has been detected and the internal sampling clock has started.  
When a HIGH level is detected, the start bit detection circuit is reset and goes into a wait status until the next start bit.  
(Time as far as AC is excluded.)

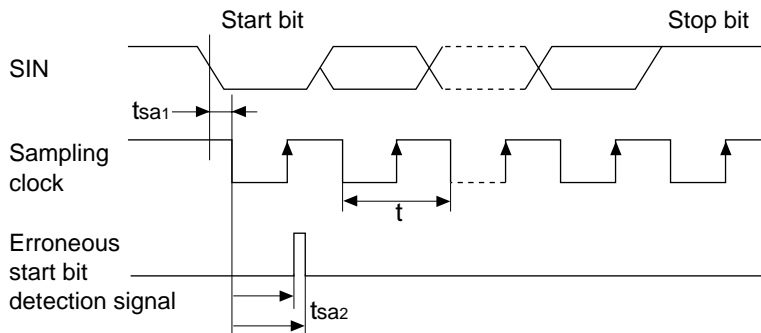
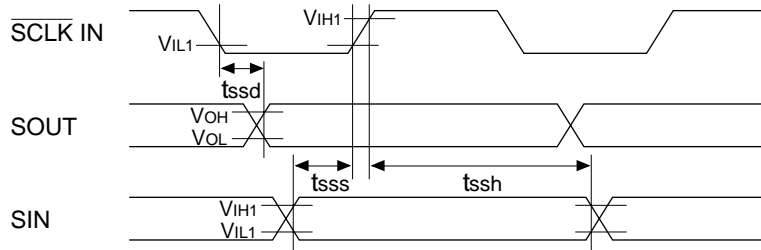
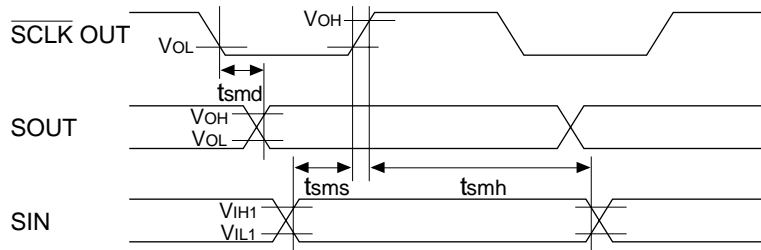

## 7 ELECTRICAL CHARACTERISTICS

### ■ Input clock

#### • OSC1, OSC3 external clock (Normal operating mode)

Condition:  $V_{DD} = 2.4$  to  $5.5$  V,  $V_{SS} = 0$  V,  $T_a = -40$  to  $85^\circ\text{C}$ ,  $V_{IH2} = 1.6$  V,  $V_{IL2} = 0.6$  V

Item	Symbol	Min.	Typ.	Max.	Unit	Note
OSC1 input clock time	Cycle time	$t_{01cy}$	20		32	$\mu\text{S}$
	"H" pulse width	$t_{01h}$	10		16	$\mu\text{S}$
	"L" pulse width	$t_{01l}$	10		16	$\mu\text{S}$
OSC3 input clock time	Cycle time	$t_{03cy}$	250		32,000	nS
	"H" pulse width	$t_{03h}$	125		16,000	nS
	"L" pulse width	$t_{03l}$	125		16,000	nS
Input clock rising time	$t_{0sr}$			25	nS	
Input clock falling time	$t_{0sf}$			25	nS	

#### • OSC1, OSC3 external clock (High speed operating mode)

Condition:  $V_{DD} = 3.5$  to  $5.5$  V,  $V_{SS} = 0$  V,  $T_a = -40$  to  $85^\circ\text{C}$ ,  $V_{IH2} = 2.4$  V,  $V_{IL2} = 0.9$  V

Item	Symbol	Min.	Typ.	Max.	Unit	Note
OSC1 input clock time	Cycle time	$t_{01cy}$	20		32	$\mu\text{S}$
	"H" pulse width	$t_{01h}$	10		16	$\mu\text{S}$
	"L" pulse width	$t_{01l}$	10		16	$\mu\text{S}$
OSC3 input clock time	Cycle time	$t_{03cy}$	125		32,000	nS
	"H" pulse width	$t_{03h}$	62.5		16,000	nS
	"L" pulse width	$t_{03l}$	62.5		16,000	nS
Input clock rising time	$t_{0sr}$			25	nS	
Input clock falling time	$t_{0sf}$			25	nS	

#### • OSC1, OSC3 external clock (Low power operating mode)

Condition:  $V_{DD} = 1.8$  to  $3.5$  V,  $V_{SS} = 0$  V,  $T_a = -40$  to  $85^\circ\text{C}$ ,  $V_{IH2} = 1.0$  V,  $V_{IL2} = 0.3$  V

Item	Symbol	Min.	Typ.	Max.	Unit	Note
OSC1 input clock time	Cycle time	$t_{01cy}$	20		32	$\mu\text{S}$
	"H" pulse width	$t_{01h}$	10		16	$\mu\text{S}$
	"L" pulse width	$t_{01l}$	10		16	$\mu\text{S}$
Input clock rising time	$t_{0sr}$			25	nS	
Input clock falling time	$t_{0sf}$			25	nS	

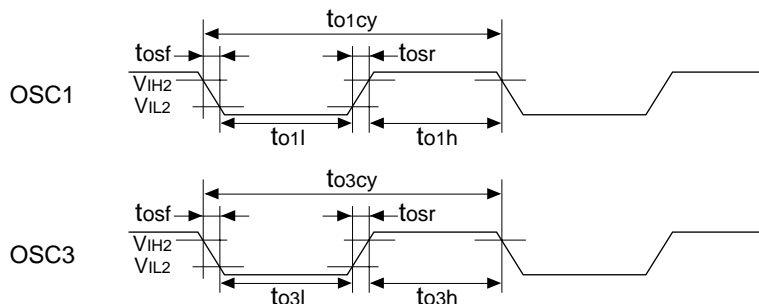



• **SCLK, EVIN input clock (Normal operating mode)**

Condition:  $V_{DD} = 2.4$  to  $5.5$  V,  $V_{SS} = 0$  V,  $T_a = -40$  to  $85^\circ\text{C}$ ,  $V_{IH1} = 0.8V_{DD}$ ,  $V_{IL1} = 0.2V_{DD}$

Item	System	Min.	Typ.	Max.	Unit	Note
SCLK input clock time	Cycle time	$t_{scyc}$	4		$\mu\text{S}$	
	"H" pulse width	$t_{sch}$	2		$\mu\text{S}$	
	"L" pulse width	$t_{scl}$	2		$\mu\text{S}$	
EVIN input clock time (With noise rejector)	Cycle time	$t_{evcy}$	$64 / f_{OSC1}$		S	
	"H" pulse width	$t_{evh}$	$32 / f_{OSC1}$		S	
	"L" pulse width	$t_{evl}$	$32 / f_{OSC1}$		S	
EVIN input clock time (Without noise rejector)	Cycle time	$t_{evcy}$	4		$\mu\text{S}$	
	"H" pulse width	$t_{evh}$	2		$\mu\text{S}$	
	"L" pulse width	$t_{evl}$	2		$\mu\text{S}$	
Input clock rising time	$t_{ckr}$			25	nS	
Input clock falling time	$t_{ckf}$			25	nS	

• **SCLK, EVIN input clock (High speed operating mode)**

Condition:  $V_{DD} = 3.5$  to  $5.5$  V,  $V_{SS} = 0$  V,  $T_a = -40$  to  $85^\circ\text{C}$ ,  $V_{IH1} = 0.8V_{DD}$ ,  $V_{IL1} = 0.2V_{DD}$

Item	System	Min.	Typ.	Max.	Unit	Note
SCLK input clock time	Cycle time	$t_{scyc}$	2		$\mu\text{S}$	
	"H" pulse width	$t_{sch}$	1		$\mu\text{S}$	
	"L" pulse width	$t_{scl}$	1		$\mu\text{S}$	
EVIN input clock time (With noise rejector)	Cycle time	$t_{evcy}$	$64 / f_{OSC1}$		S	
	"H" pulse width	$t_{evh}$	$32 / f_{OSC1}$		S	
	"L" pulse width	$t_{evl}$	$32 / f_{OSC1}$		S	
EVIN input clock time (Without noise rejector)	Cycle time	$t_{evcy}$	2		$\mu\text{S}$	
	"H" pulse width	$t_{evh}$	1		$\mu\text{S}$	
	"L" pulse width	$t_{evl}$	1		$\mu\text{S}$	
Input clock rising time	$t_{ckr}$			25	nS	
Input clock falling time	$t_{ckf}$			25	nS	

• **SCLK, EVIN input clock (Low power operating mode)**

Condition:  $V_{DD} = 1.8$  to  $3.5$  V,  $V_{SS} = 0$  V,  $T_a = -40$  to  $85^\circ\text{C}$ ,  $V_{IH1} = 0.8V_{DD}$ ,  $V_{IL1} = 0.2V_{DD}$

Item	System	Min.	Typ.	Max.	Unit	Note
SCLK input clock time	Cycle time	$t_{scyc}$	100		$\mu\text{S}$	
	"H" pulse width	$t_{sch}$	50		$\mu\text{S}$	
	"L" pulse width	$t_{scl}$	50		$\mu\text{S}$	
EVIN input clock time (With noise rejector)	Cycle time	$t_{evcy}$	$64 / f_{OSC1}$		S	
	"H" pulse width	$t_{evh}$	$32 / f_{OSC1}$		S	
	"L" pulse width	$t_{evl}$	$32 / f_{OSC1}$		S	
EVIN input clock time (Without noise rejector)	Cycle time	$t_{evcy}$	100		$\mu\text{S}$	
	"H" pulse width	$t_{evh}$	50		$\mu\text{S}$	
	"L" pulse width	$t_{evl}$	50		$\mu\text{S}$	
Input clock rising time	$t_{ckr}$			25	nS	
Input clock falling time	$t_{ckf}$			25	nS	

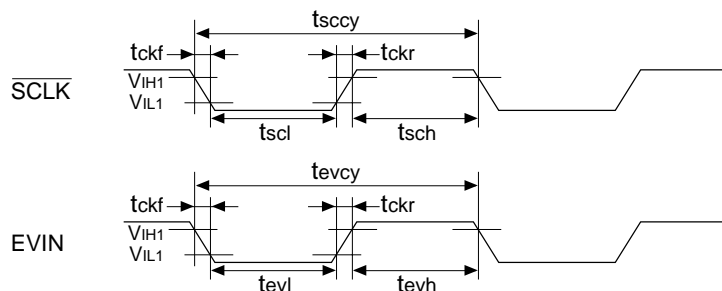

## 7 ELECTRICAL CHARACTERISTICS

### • $\overline{\text{RESET}}$ input clock (All operating mode)

Condition:  $V_{DD} = 1.8$  to  $5.5$  V,  $V_{SS} = 0$  V,  $T_a = -40$  to  $85^\circ\text{C}$ ,  $V_{IH} = 0.5V_{DD}$ ,  $V_{IL} = 0.1V_{DD}$

Item	Symbol	Min.	Typ.	Max.	Unit	Note
$\overline{\text{RESET}}$ input time	$t_{sr}$	100			$\mu\text{S}$	

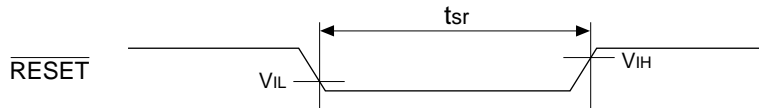

### ■ Power ON reset

Condition:  $V_{SS} = 0$  V,  $T_a = -40$  to  $85^\circ\text{C}$

Item	Symbol	Min.	Typ.	Max.	Unit	Note
Operating power voltage	$V_{sr}$	2.4			V	
$\overline{\text{RESET}}$ input time	$t_{psr}$	10			mS	

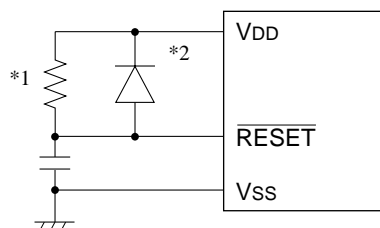
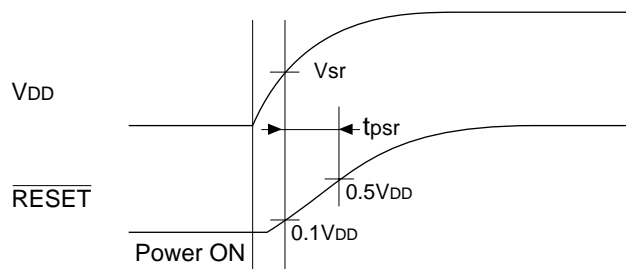

\*1 When the built-in pull up resistor is not used.

\*2 Because the potential of the  $\overline{\text{RESET}}$  terminal not reached  $V_{DD}$  level or higher.

### ■ Operating mode switching

Condition:  $V_{DD} = 1.8$  to  $5.5$  V,  $V_{SS} = 0$  V,  $T_a = -40$  to  $85^\circ\text{C}$

Item	Symbol	Min.	Typ.	Max.	Unit	Note
Stabilization time	$t_{vdc}$	5			mS	1

Note) 1 Stabilization time is the time from switching on the operating mode until operating mode is stabilized. For example, when turning the OSC3 oscillation circuit on, stabilization time is needed after the operating mode is switched on.

## 7.7 Oscillation Characteristics

Oscillation characteristics change depending on conditions (board pattern, components used, etc.). Use the following characteristics as reference values. In particular, when a ceramic oscillator is used for OSC3, use the oscillator manufacturer's recommended values for constants such as capacitance and resistance. The oscillation start time is important because it becomes the wait time when OSC3 clock is used. (If OSC3 is used as CPU clock before oscillation stabilizes, the CPU may malfunction.)

### ■ OSC1 (Crystal)

*Unless otherwise specified:* V<sub>DD</sub> = Within the operating voltage in each operating mode, V<sub>SS</sub> = 0 V, T<sub>a</sub> = 25°C,

Crystal oscillator = C2-TYPE\*, C<sub>G1</sub> = 25 pF, C<sub>D1</sub> = Built-in

Item	Symbol	Condition	Min.	Typ.	Max.	Unit	Note
Oscillation start time	t <sub>sta</sub>				3	S	
External gate capacitance	C <sub>G1</sub>	Including board capacitance	5		25	pF	1
Built-in gate capacitance	C <sub>G1</sub>	In case of the chip		15		pF	2
Built-in drain capacitance	C <sub>D1</sub>	In case of the chip		15		pF	
Frequency/IC deviation	∂f/∂IC	V <sub>DD</sub> = constant	-10		10	ppm	
Frequency/power voltage deviation	∂f/∂V				1	ppm/V	
Frequency adjustment range	∂f/∂C <sub>G</sub>	V <sub>DD</sub> = constant, C <sub>G</sub> = 5 to 25pF	25			ppm	
Frequency/operating mode deviation	∂f/∂MD	V <sub>DD</sub> = constant			20	ppm	

\* C2-TYPE Made by Seiko Epson corporation

Note) 1 When crystal oscillation is selected by the mask option.

2 When crystal oscillation (gate capacitor built-in) is selected by the mask option.

### ■ OSC1 (CR)

*Unless otherwise specified:* V<sub>DD</sub> = 2.4 to 5.5 V, V<sub>SS</sub> = 0 V, T<sub>a</sub> = -40 to 85°C

Item	Symbol	Condition	Min.	Typ.	Max.	Unit	Note
Oscillation start time	t <sub>sta</sub>				3	mS	
Frequency/IC deviation	∂f/∂IC	R <sub>CR</sub> = constant	-25		25	%	

### ■ OSC3 (Crystal)

*Unless otherwise specified:* V<sub>DD</sub> = Within the operating voltage in each operating mode, V<sub>SS</sub> = 0 V, T<sub>a</sub> = 25°C,

Crystal oscillator = CA-301 4MHz / CA-301 8MHz\*, R<sub>F</sub> = 1MΩ, C<sub>G2</sub> = C<sub>D2</sub> = 15pF

Item	Symbol	Condition	Min.	Typ.	Max.	Unit	Note
Oscillation start time (Normal mode)	t <sub>sta</sub>	4.0 MHz crystal oscillator			20	mS	1
Oscillation start time (High speed mode)	t <sub>sta</sub>	8.0 MHz crystal oscillator			20	mS	1

\* CA-301 4MHz / CA-301 8MHz Made by Seiko Epson corporation

Note) 1 The crystal oscillation start time changes by the crystal oscillator to be used, C<sub>G2</sub> and C<sub>D2</sub>.

### ■ OSC3 (Ceramic)

*Unless otherwise specified:* V<sub>DD</sub> = Within the operating voltage in each operating mode, V<sub>SS</sub> = 0 V, T<sub>a</sub> = 25°C,

Ceramic oscillator = CSA4.00MG / CSA8.00MTZ\*, R<sub>F</sub> = 1MΩ, C<sub>G2</sub> = C<sub>D2</sub> = 30pF

Item	Symbol	Condition	Min.	Typ.	Max.	Unit	Note
Oscillation start time (Normal mode)	t <sub>sta</sub>	4.0 MHz ceramic oscillator			5	mS	
Oscillation start time (High speed mode)	t <sub>sta</sub>	8.0 MHz ceramic oscillator			5	mS	

\* CSA4.00MG / CSA8.00MTZ Made by Murata Mfg. corporation

### ■ OSC3 (CR)

*Unless otherwise specified:* V<sub>DD</sub> = Within the operating voltage in each operating mode, V<sub>SS</sub> = 0 V, T<sub>a</sub> = -40 to 85°C

Item	Symbol	Condition	Min.	Typ.	Max.	Unit	Note
Oscillation start time (Normal mode)	t <sub>sta</sub>				1	mS	
Oscillation start time (High speed mode)	t <sub>sta</sub>				1	mS	
Frequency/IC deviation (Normal mode)	∂f/∂IC	R <sub>CR</sub> = constant	-25		25	%	
Frequency/IC deviation (High speed mode)	∂f/∂IC	R <sub>CR</sub> = constant	-25		25	%	

### 7.8 Characteristics Curves (reference value)

■ High level output current-voltage characteristic  
E0C88348/316/308

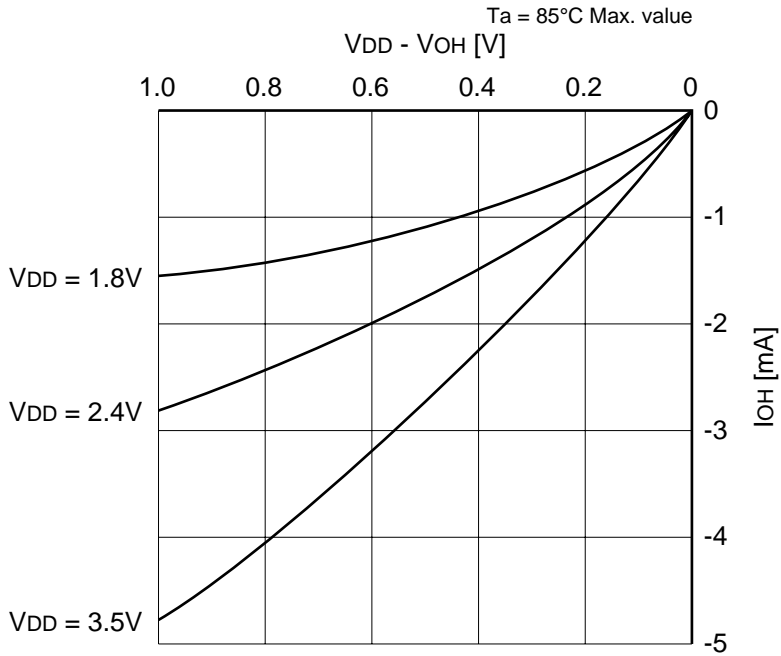

E0C88317

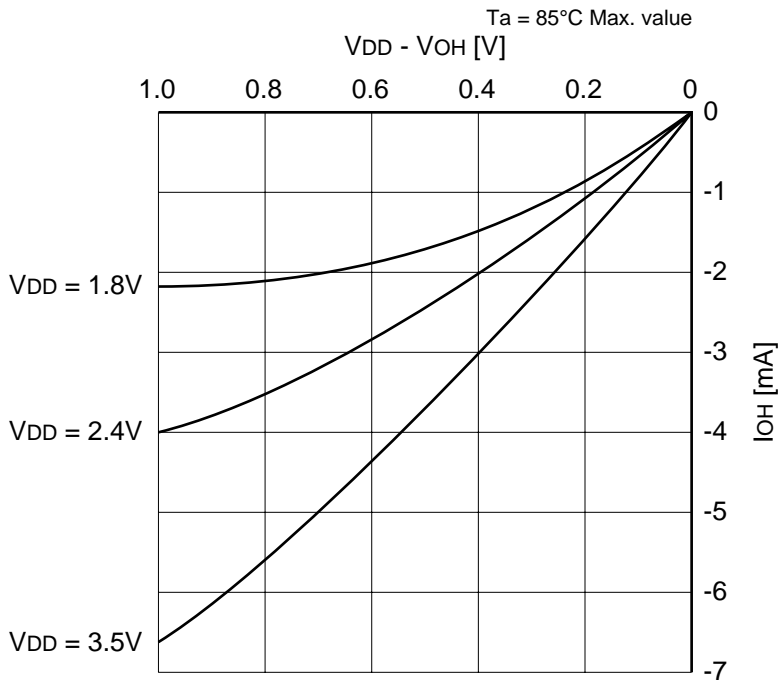

■ Low level output current-voltage characteristic  
E0C88348/316/308

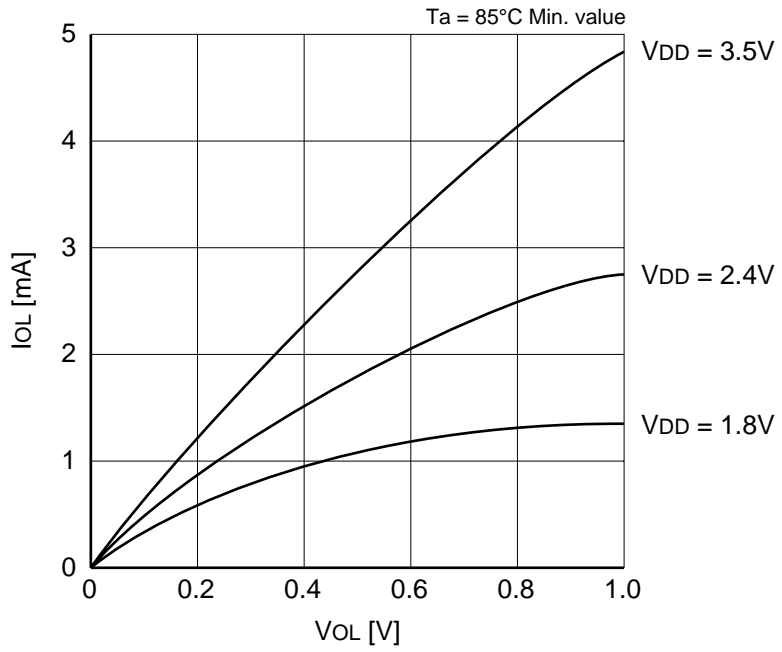

E0C88317

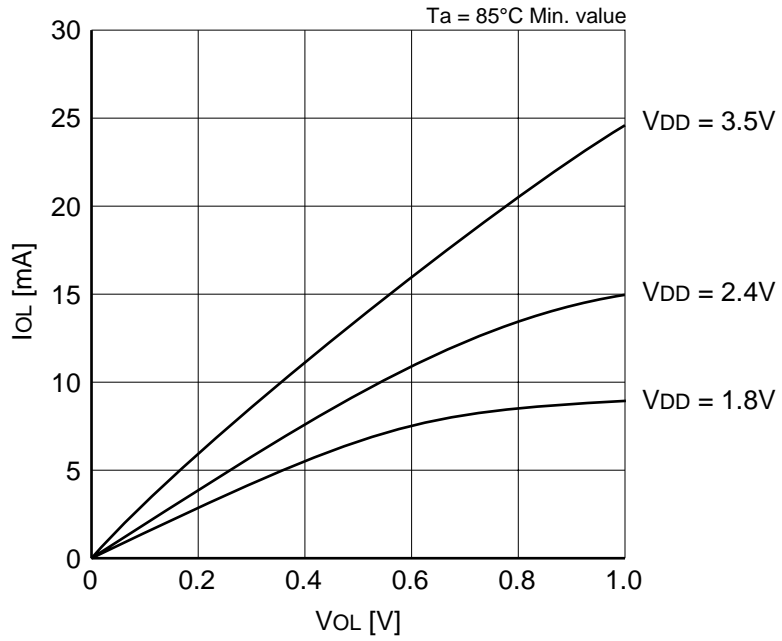

■ LCD drive voltage-ambient temperature characteristic  
E0C88348/316/308

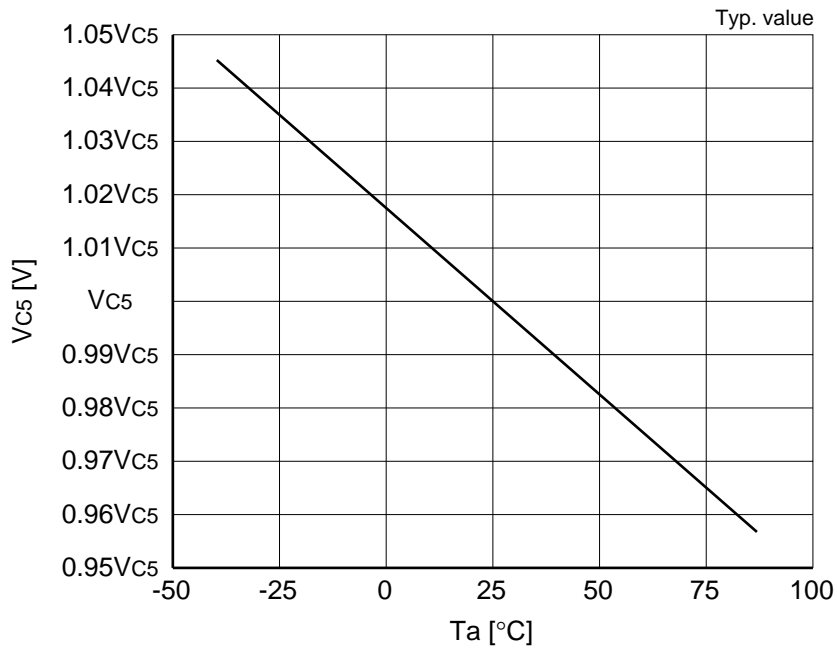

E0C88317

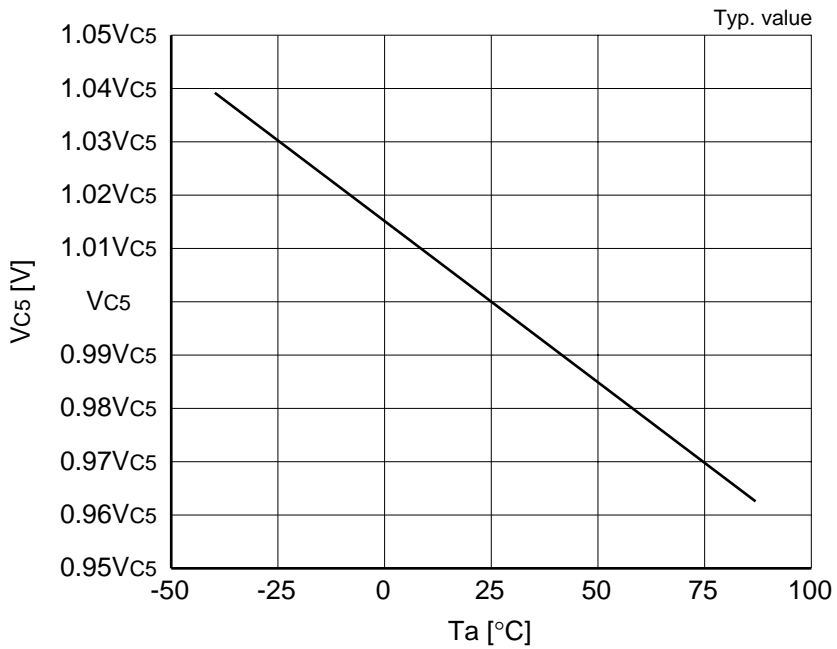

■ LCD drive voltage-supply voltage characteristic  
E0C88348/316/308

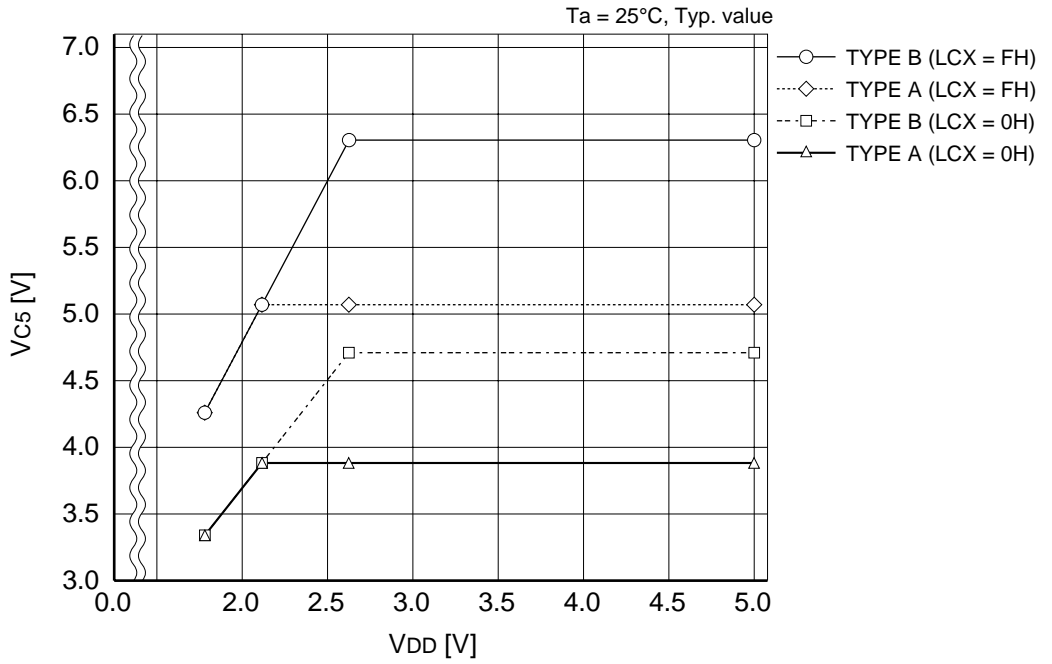

E0C88317

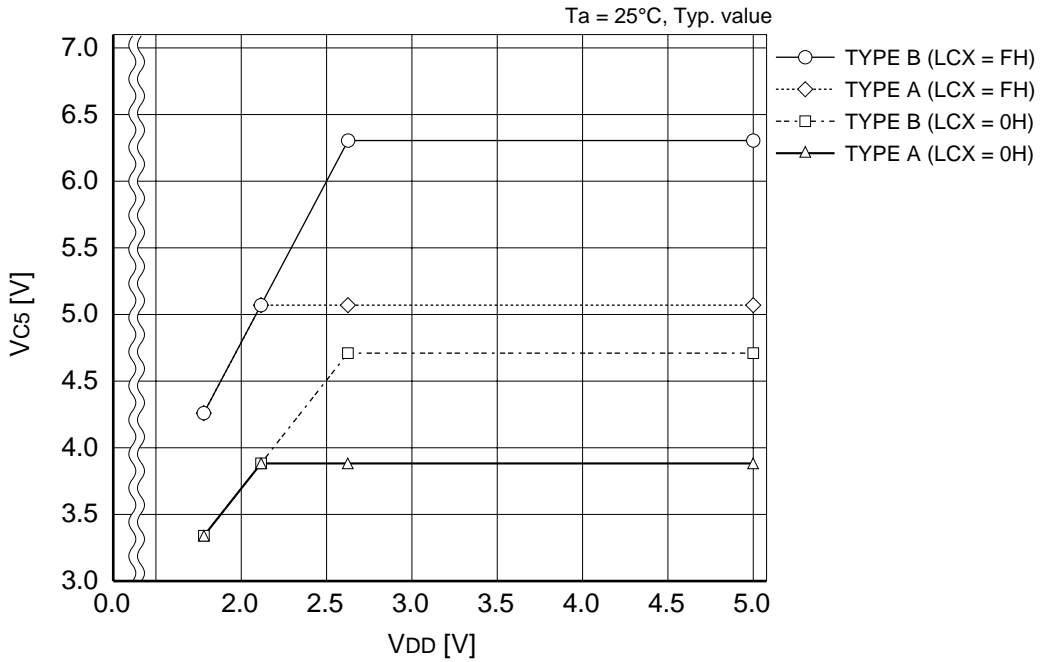

■ LCD drive voltage-load characteristic  
E0C88348/316/308

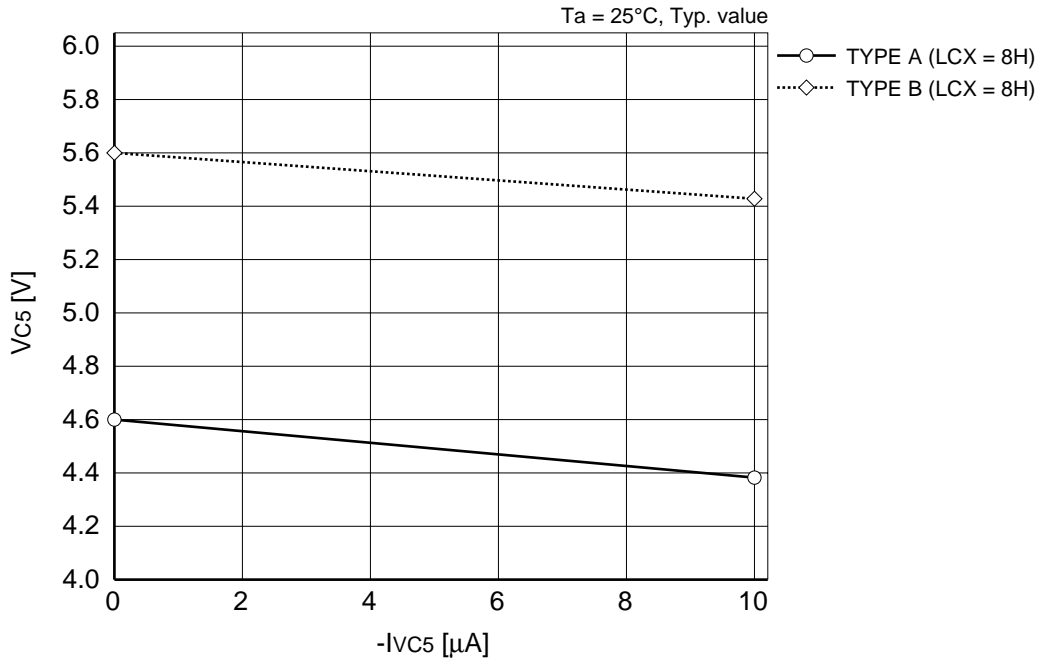

E0C88317

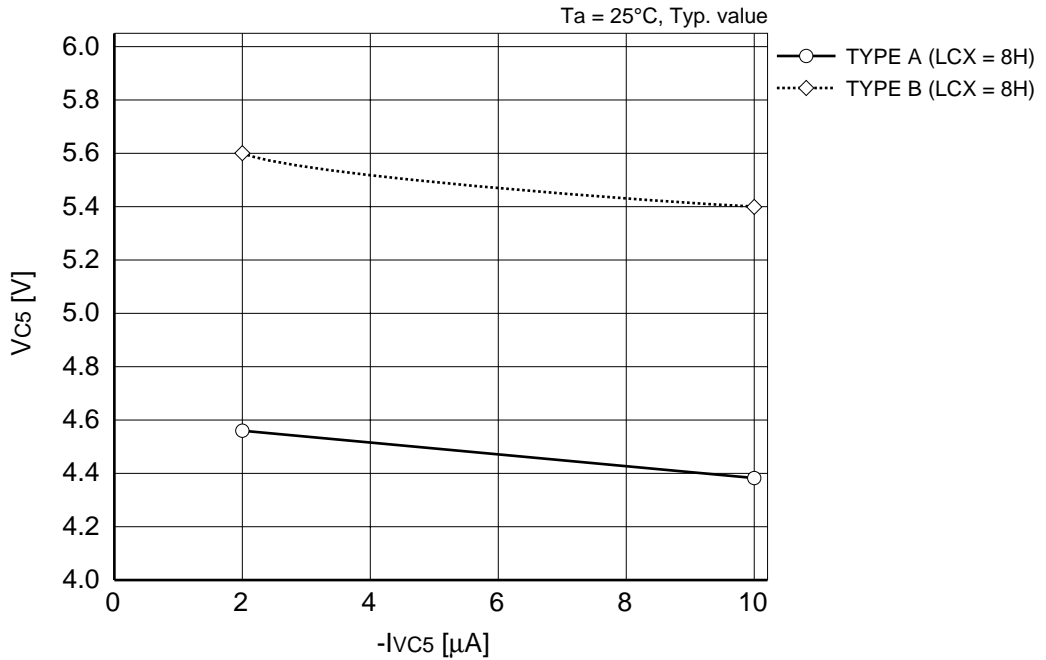



■ SVD voltage-ambient temperature characteristic  
E0C88348/316/308

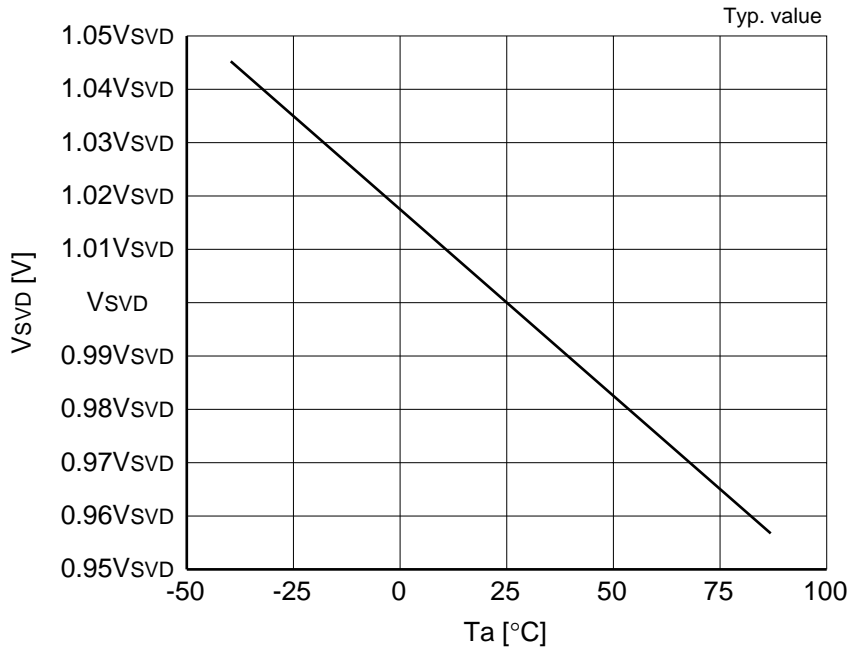

E0C88317

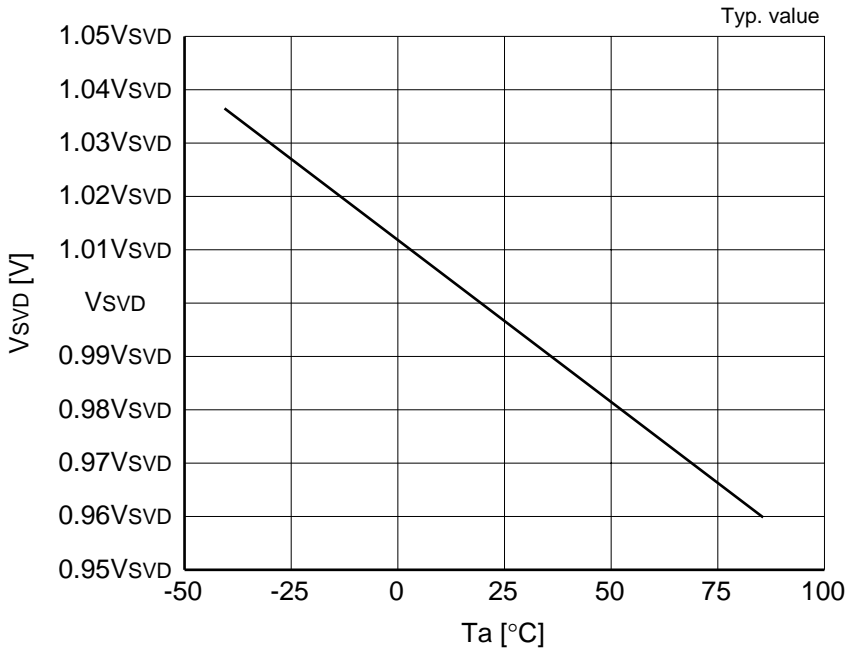

■ Power current (During operation with OSC3) <Crystal oscillation>  
E0C88348/316/308

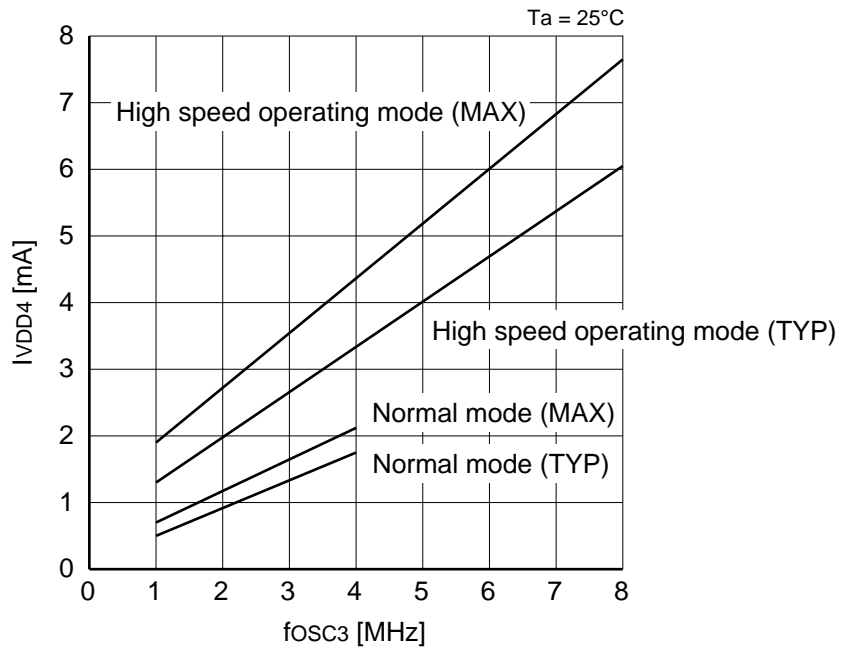

E0C88317

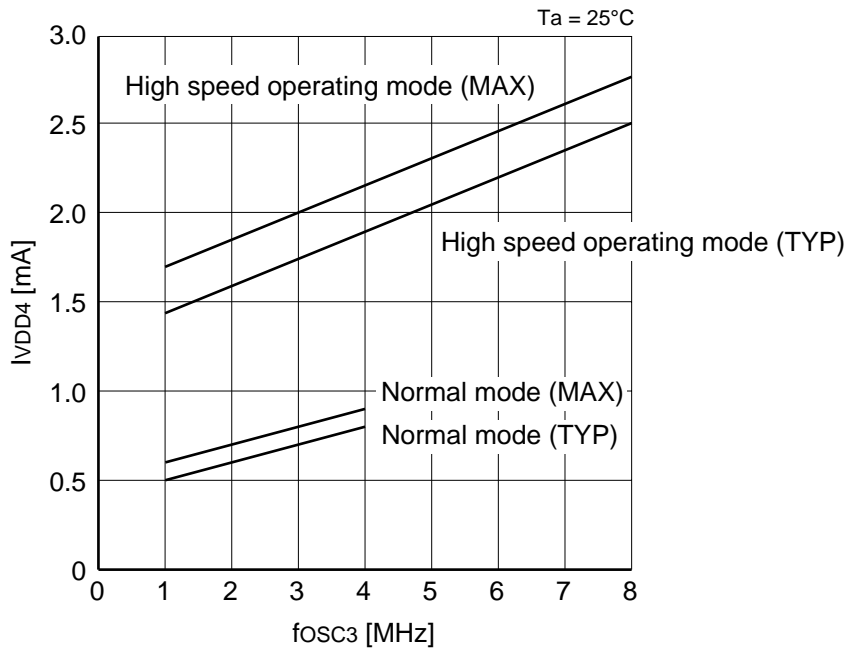

■ Power current (During operation with OSC3) <CR oscillation>  
E0C88348/316/308

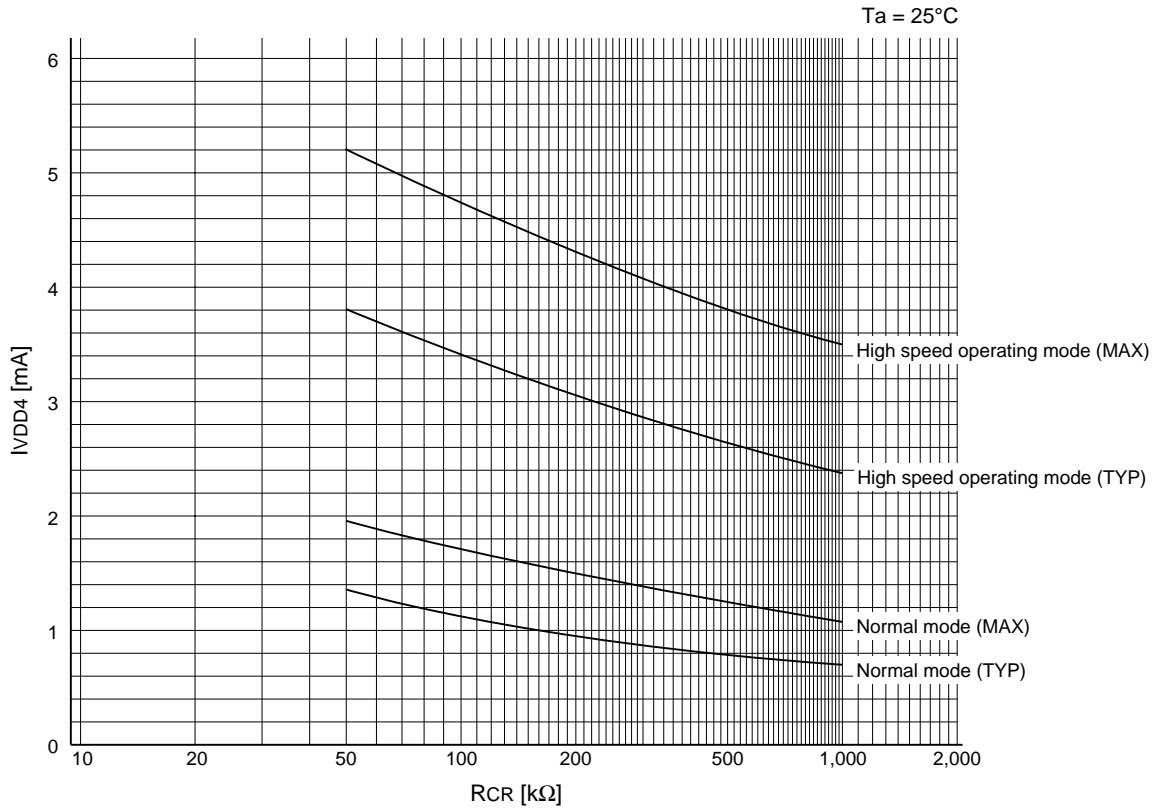

E0C88317

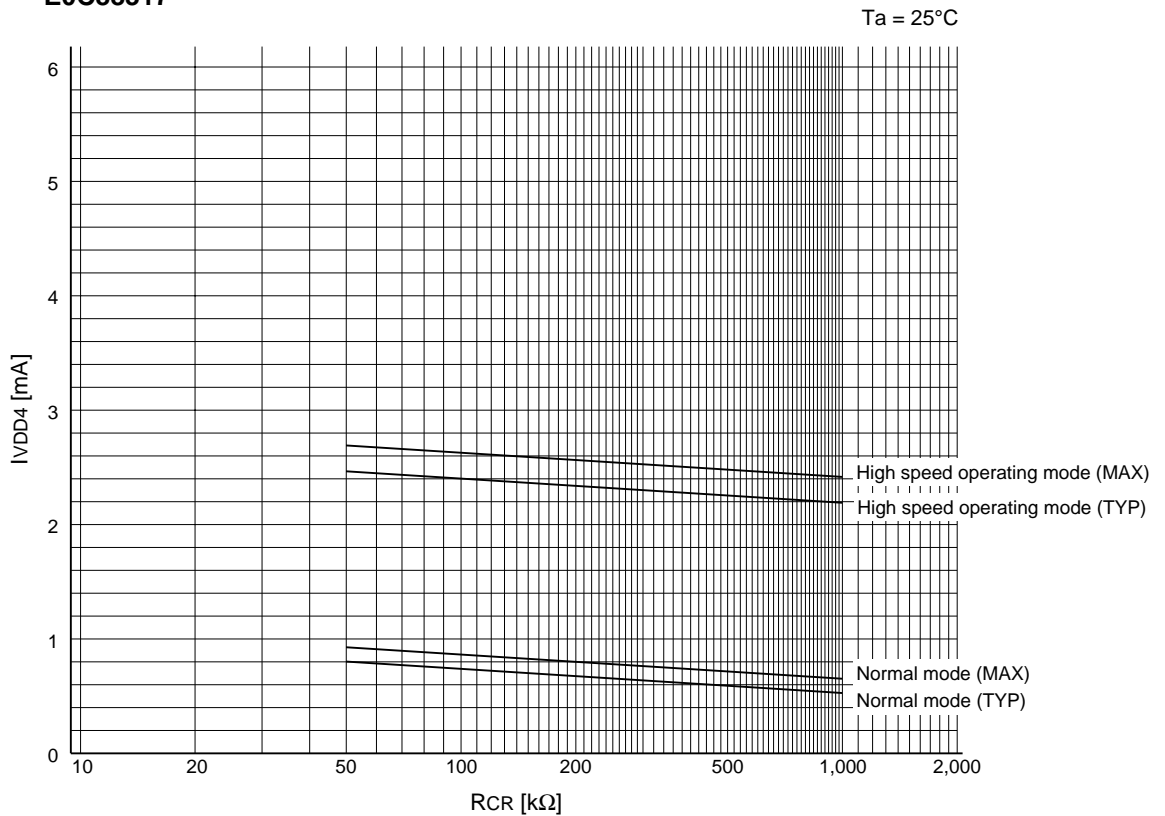

■ Power current (During operation with OSC3) <External clock>  
E0C88348/316/308

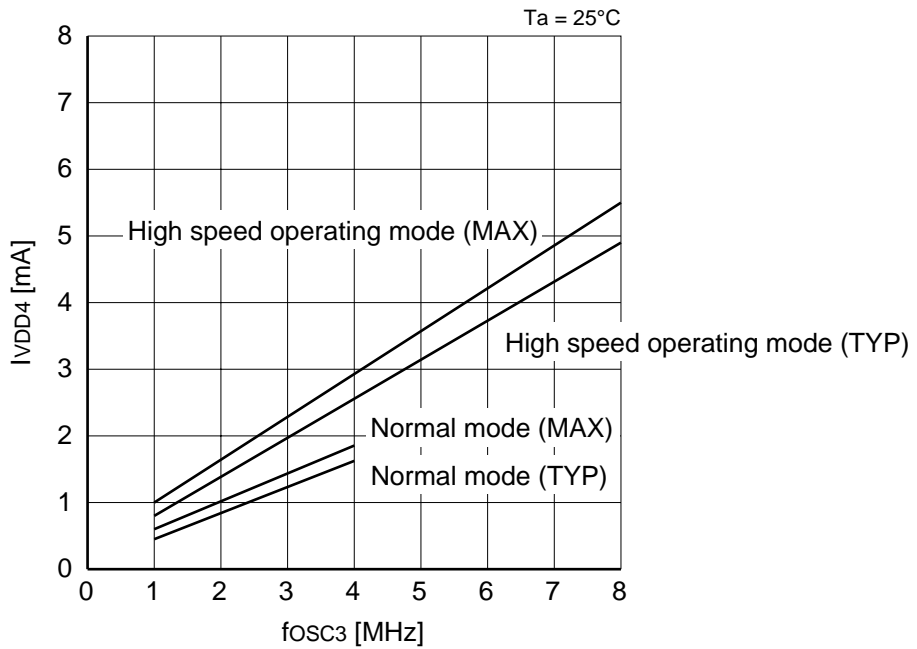

E0C88317

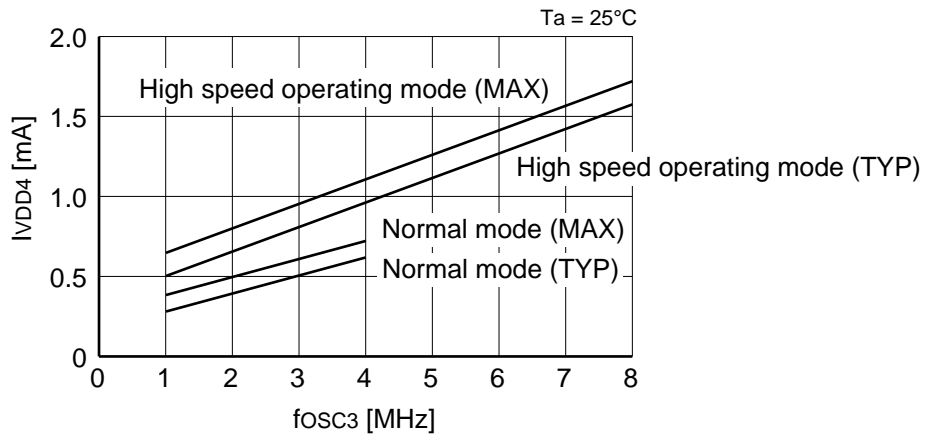

■ Power current-ambient temperature characteristic (In HALT status)  
E0C88348/316/308

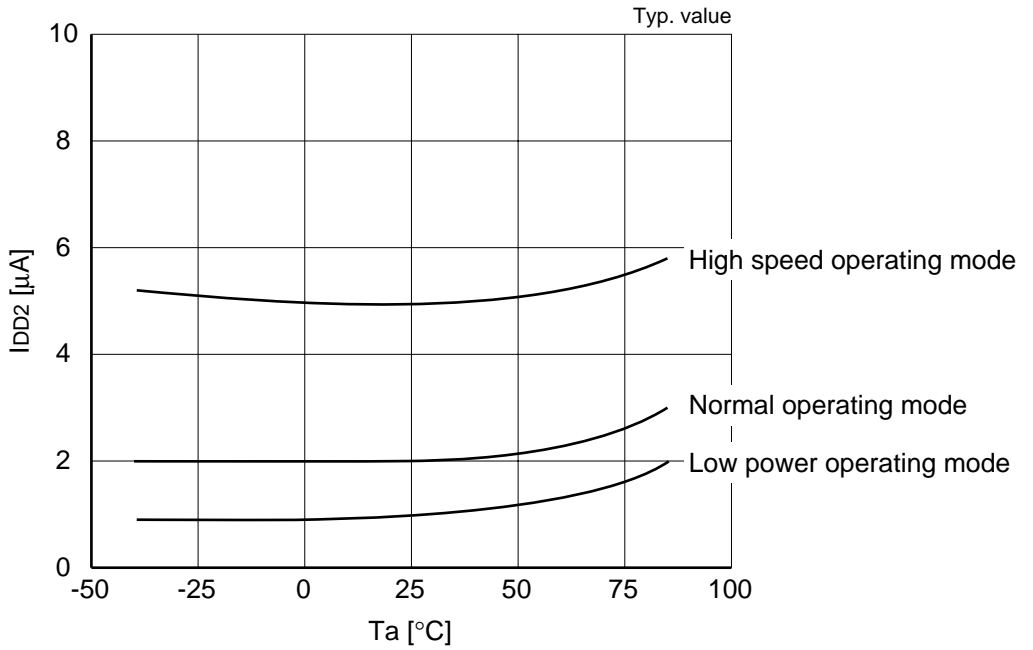

E0C88317

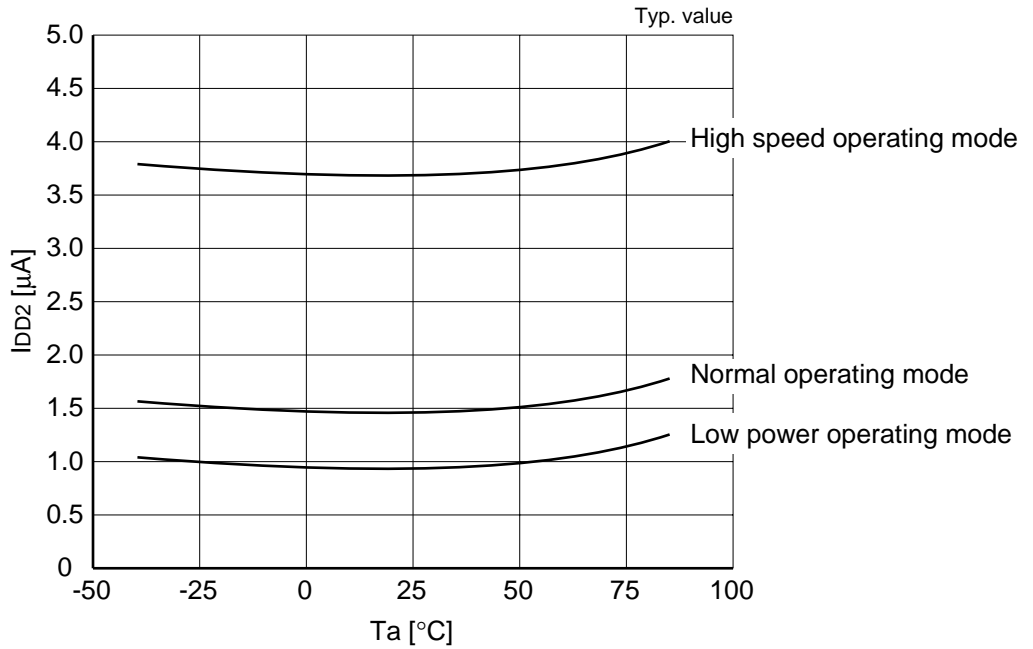

■ Power current-ambient temperature characteristic (CPU is under 32.768 kHz operation)  
E0C88348/316/308

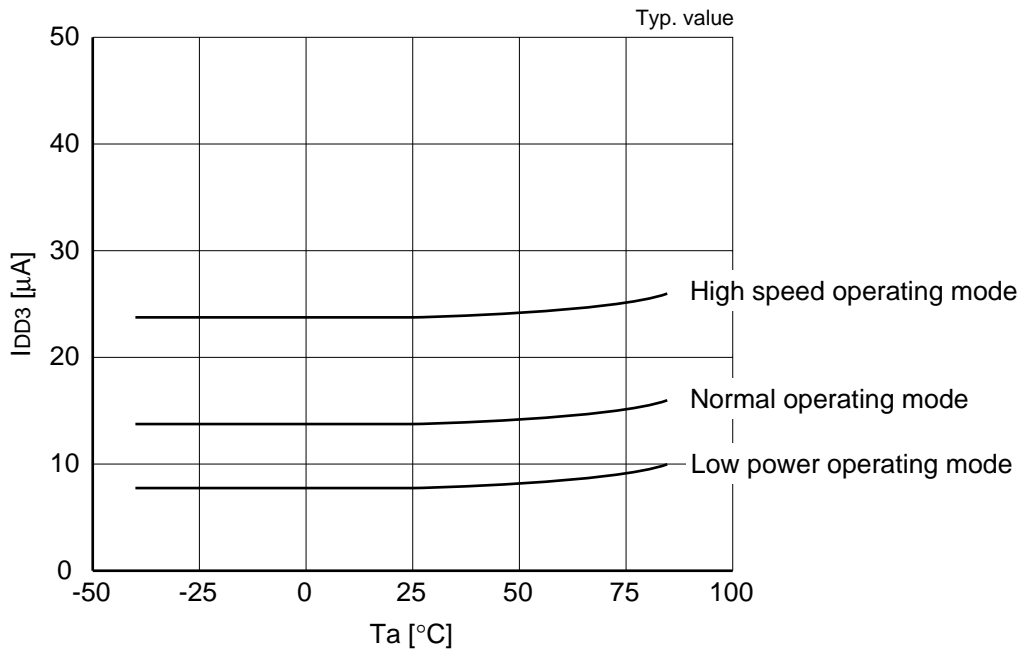

E0C88317

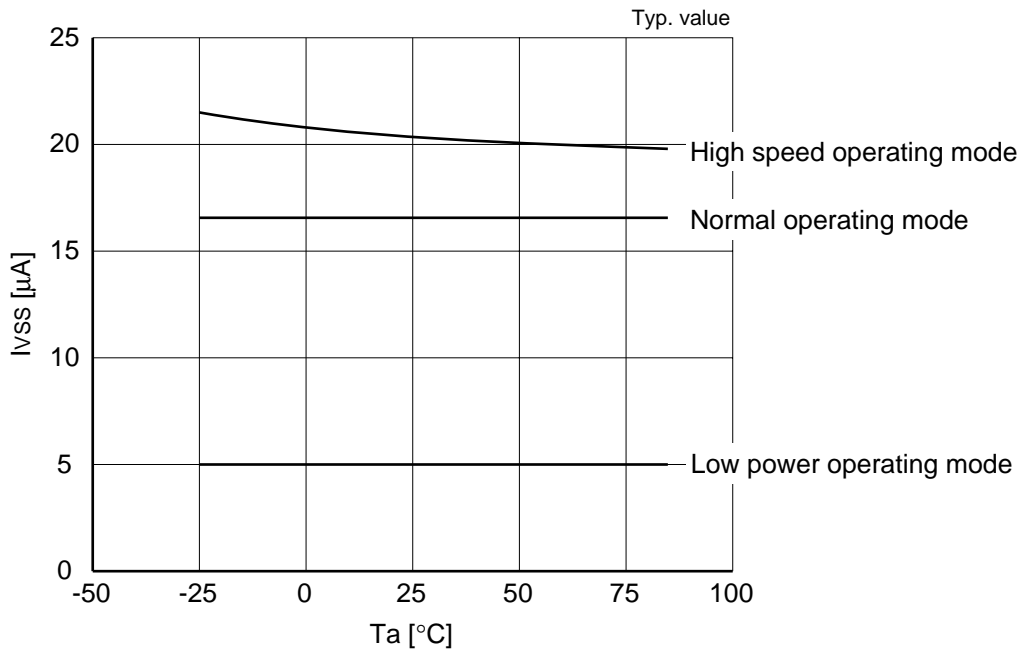

■ Power current-ambient temperature characteristic (CPU is under 1 MHz operation)  
E0C88348/316/308

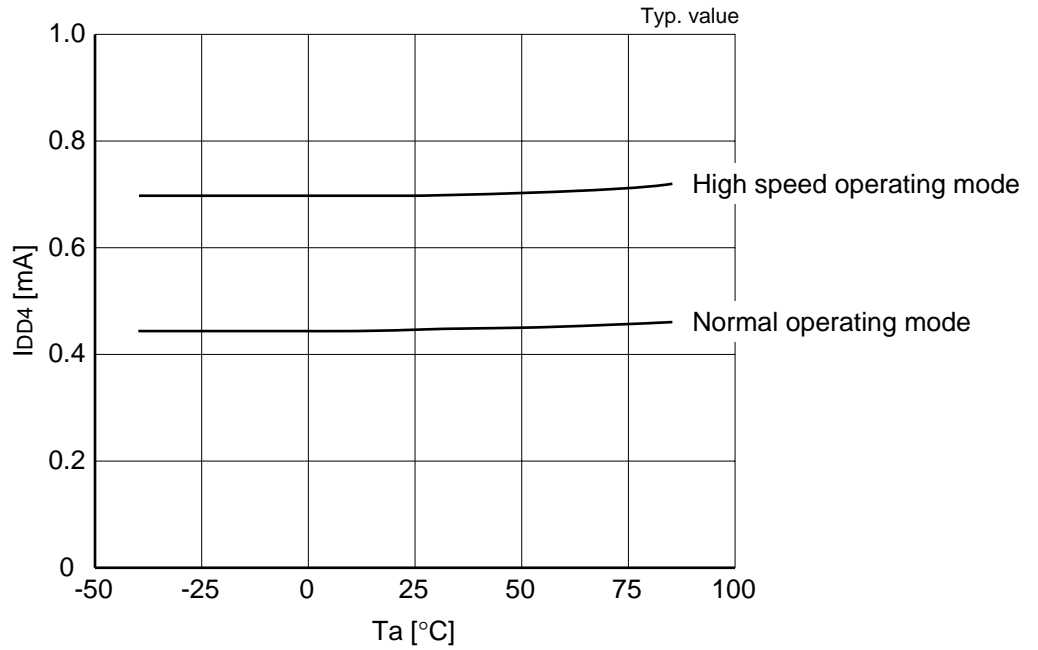

## E0C88317

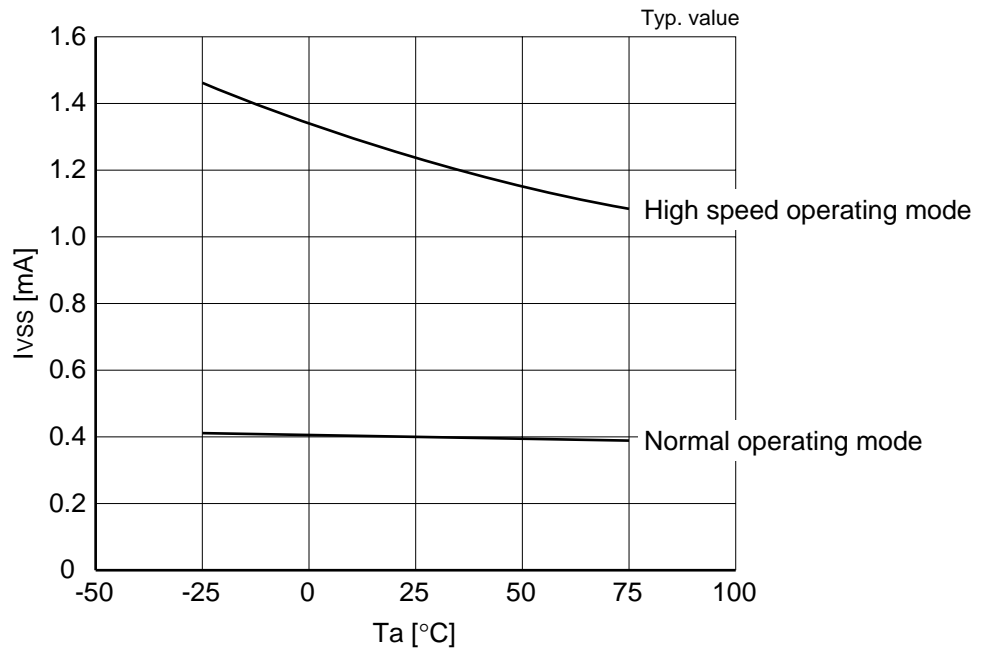

■ CR oscillation frequency characteristic

Note: Oscillation frequency changes depending on the conditions (components used, board pattern, etc.). In particular, the OSC3 oscillation frequency changes extensively depending on the product form (chip, plastic package or ceramic package) and board capacitance. Therefore, use the following charts for reference only and select the resistance value after evaluating the actual product. (The resistance value should be set to  $R_{CR} \geq 15 \text{ k}\Omega$ .)

• Oscillation frequency resistor characteristic  
E0C88348/316/308

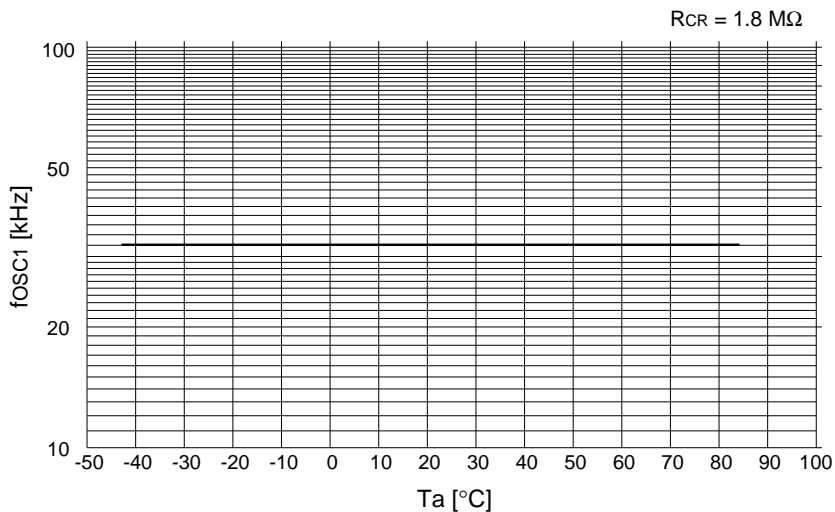
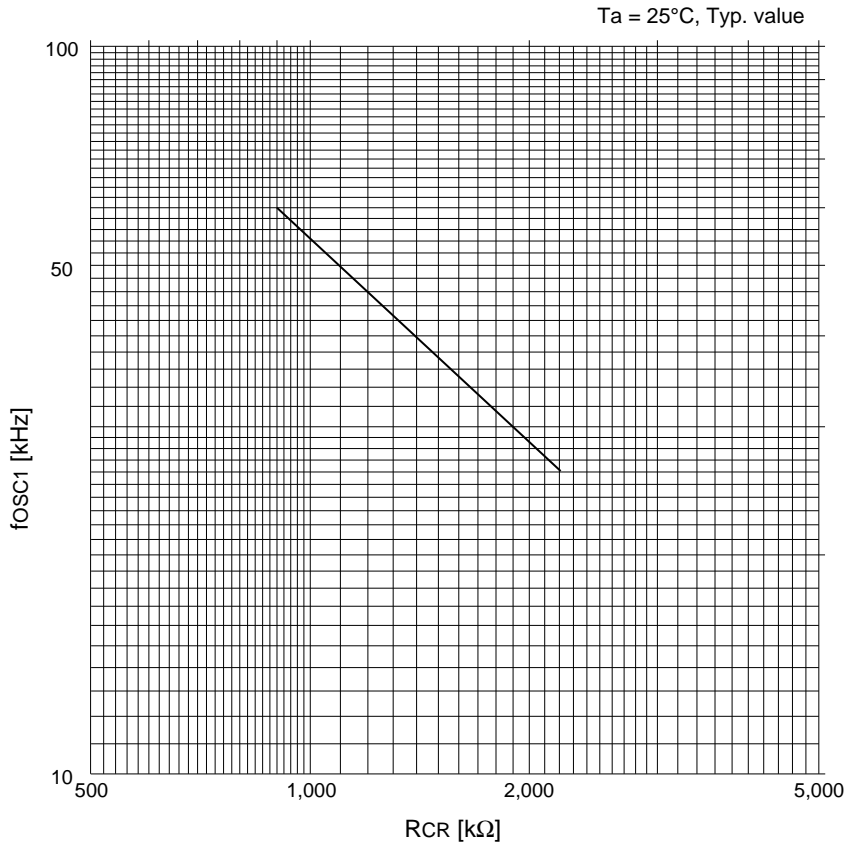



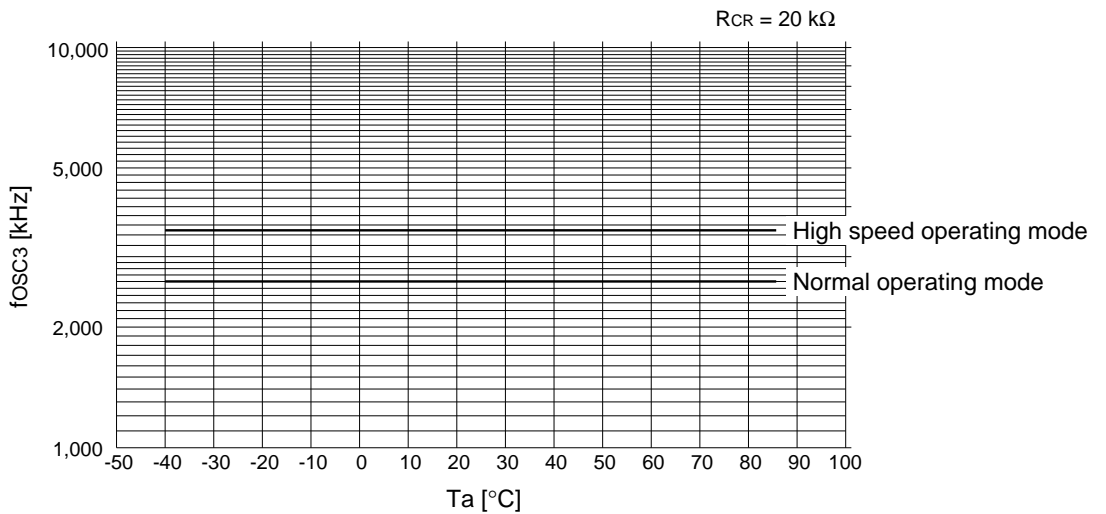
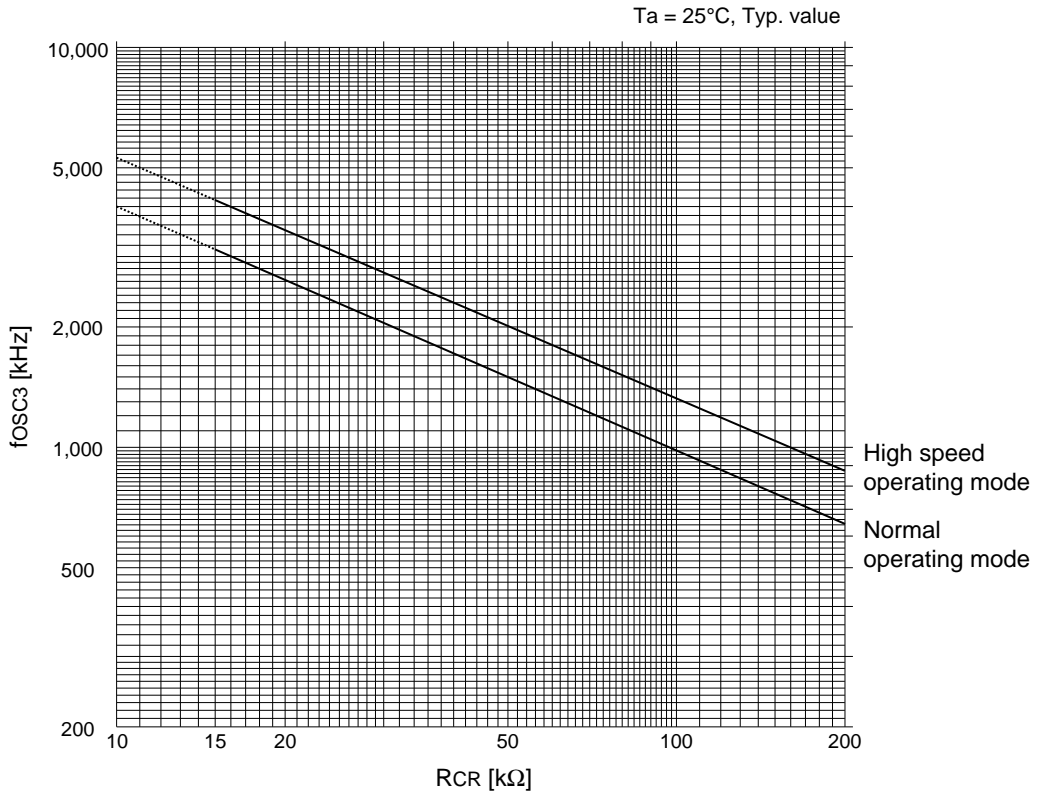

# 7 ELECTRICAL CHARACTERISTICS

## E0C88317

Ta = 25°C, Typ. value

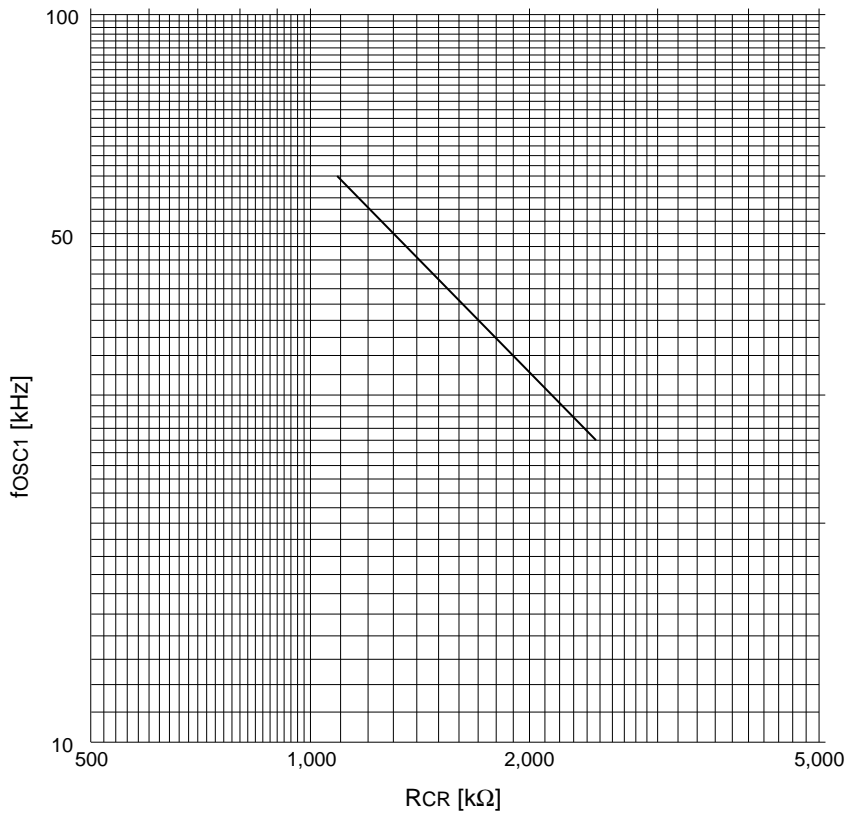

$RCR = 1.8$  M $\Omega$

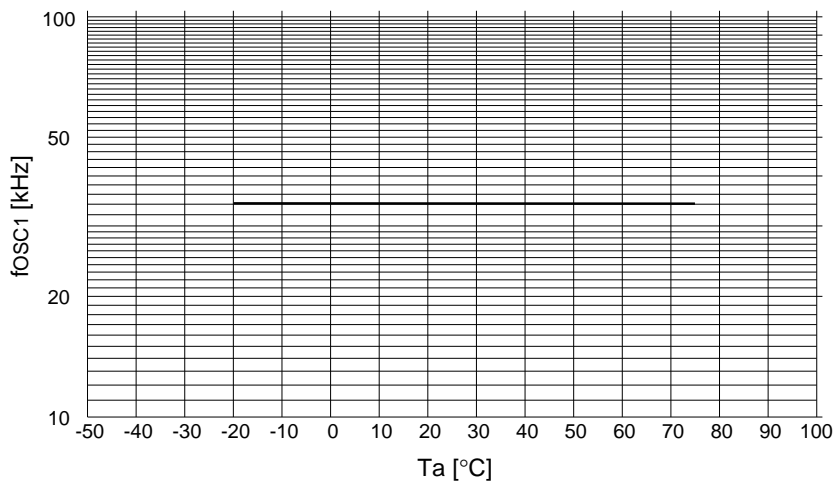

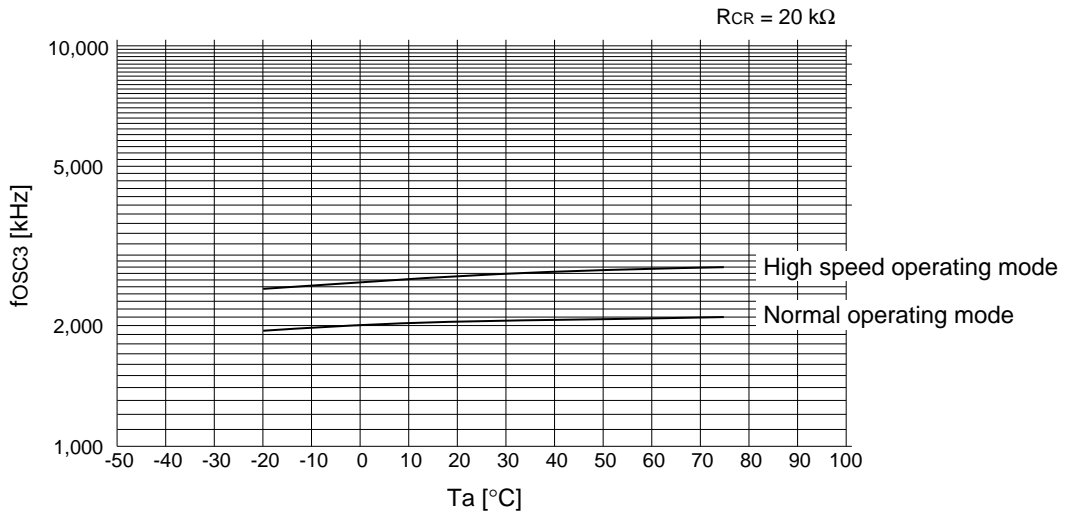
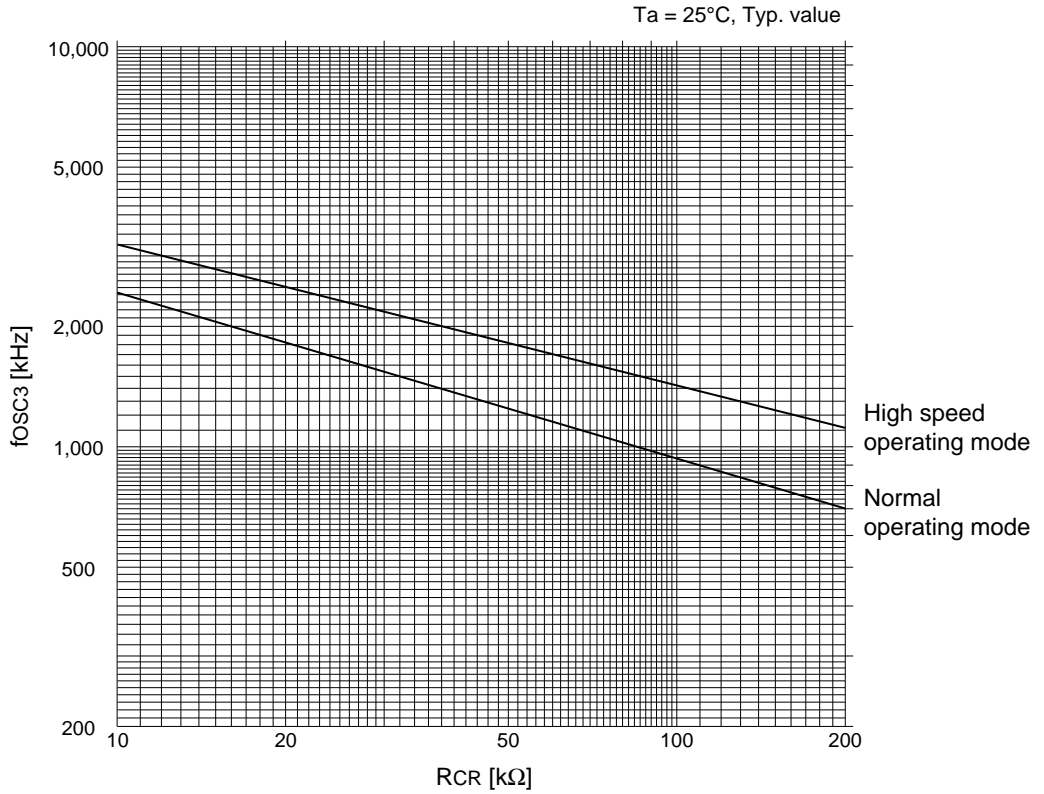



## QFP17-160pin

(Unit: mm)

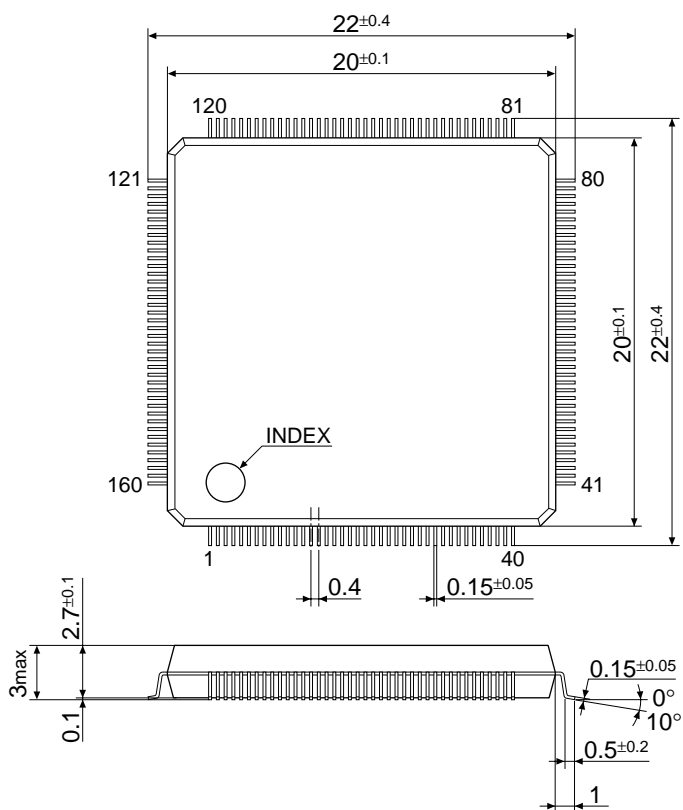

## 8.2 Ceramic Package

### QFP8-160pin

(Unit: mm)

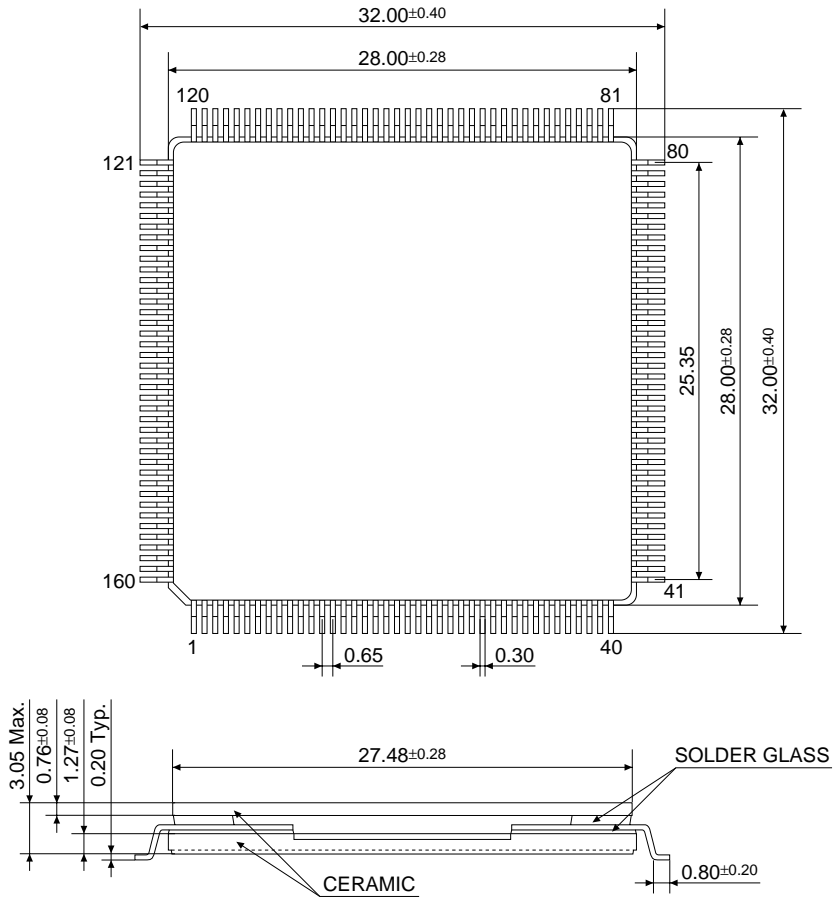

# 9 PAD LAYOUT

## 9.1 Diagram of Pad Layout

E0C88348

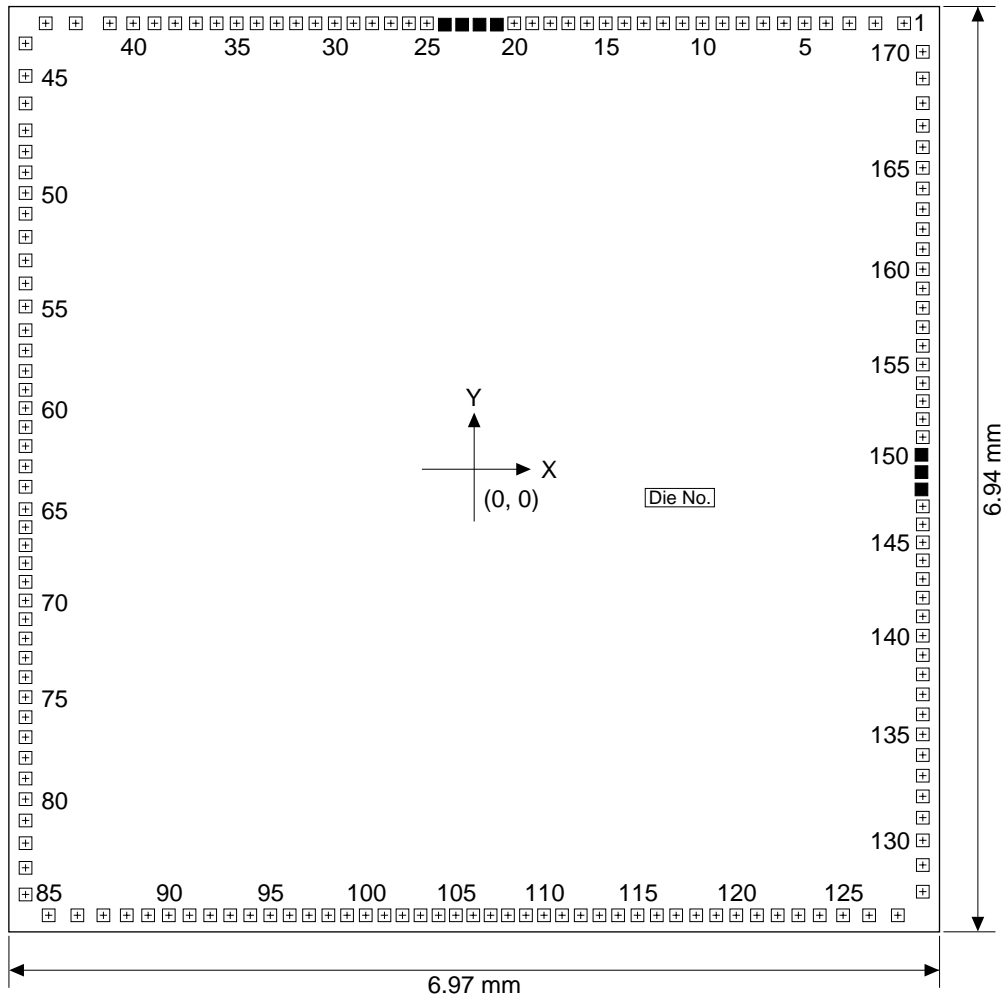

Chip thickness: 0.4 mm  
Pad opening: 95 μm

■ Pads are used for the IC shipment test, so you should not bond them.

9 PAD LAYOUT

E0C88317

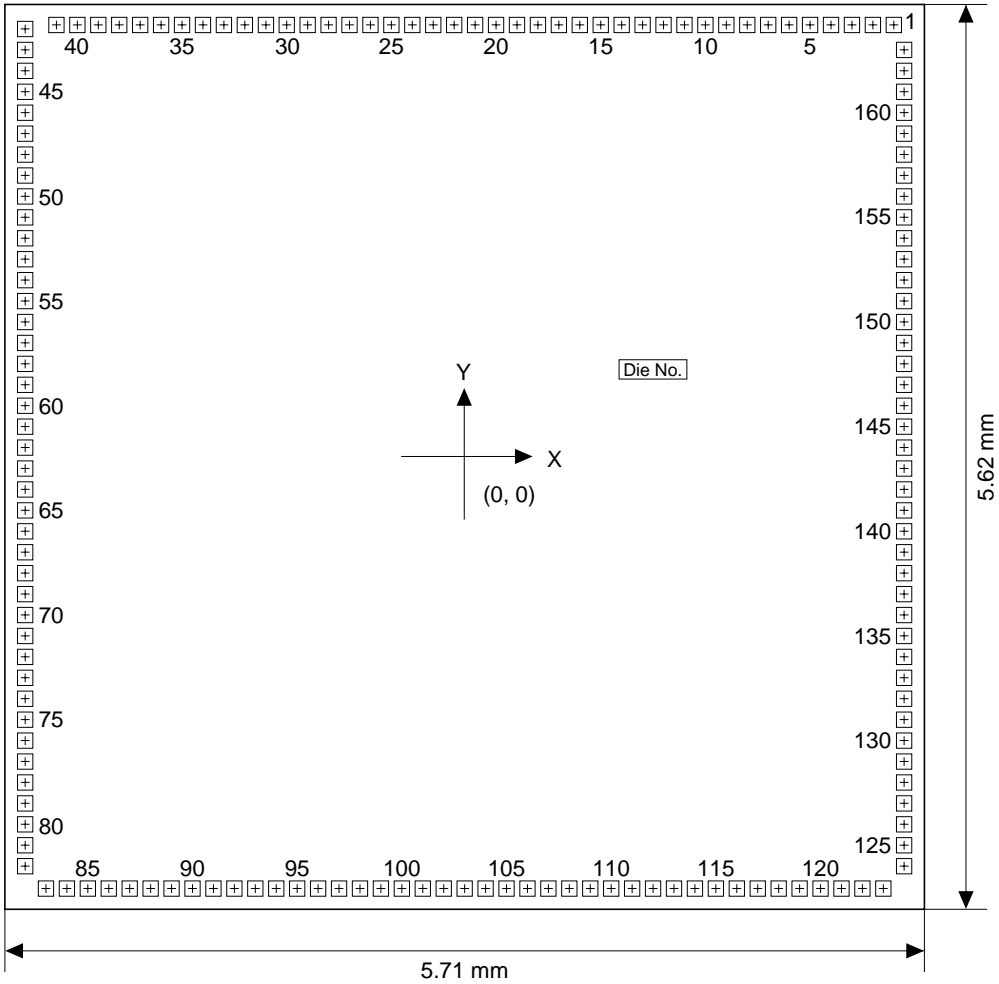

Chip thickness: 0.4 mm  
Pad opening: 95 μm



E0C88316

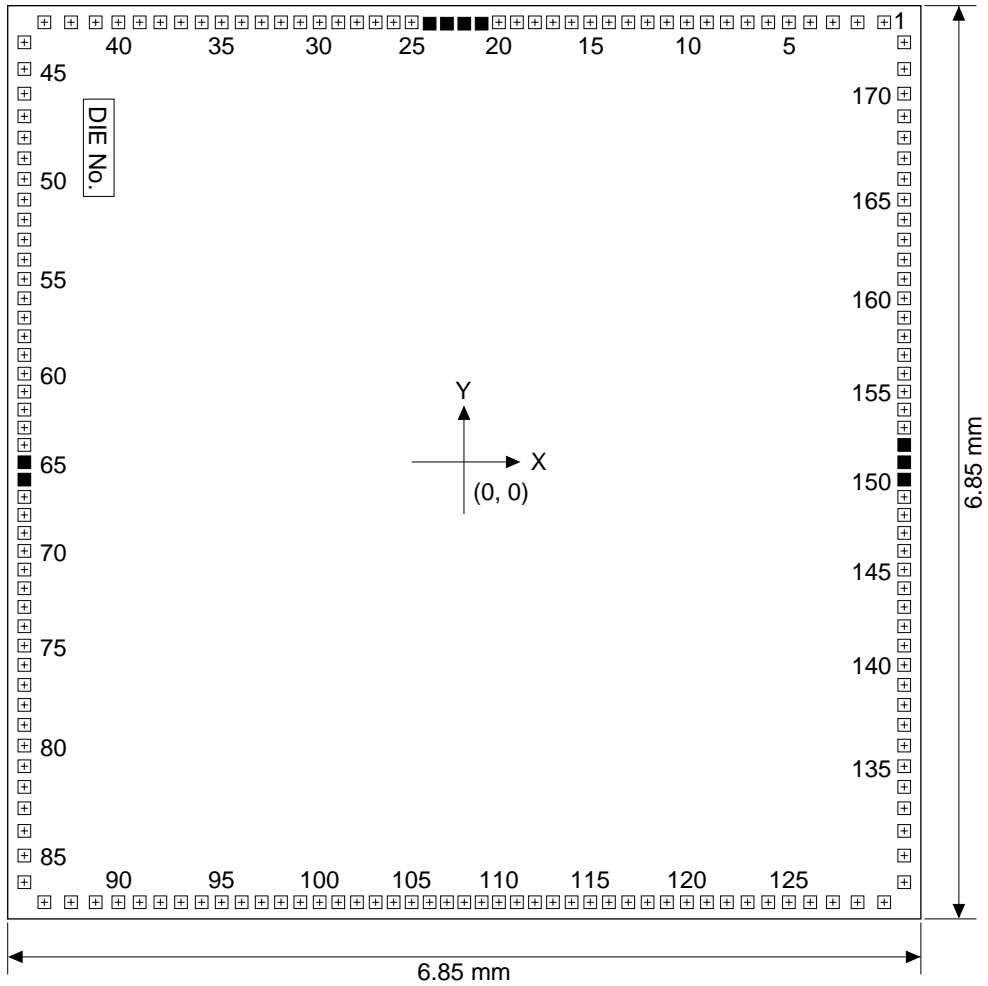

Chip thickness: 0.4 mm  
 Pad opening: 95 μm

■ Pads are used for the IC shipment test, so you should not bond them.

9 PAD LAYOUT

E0C88308

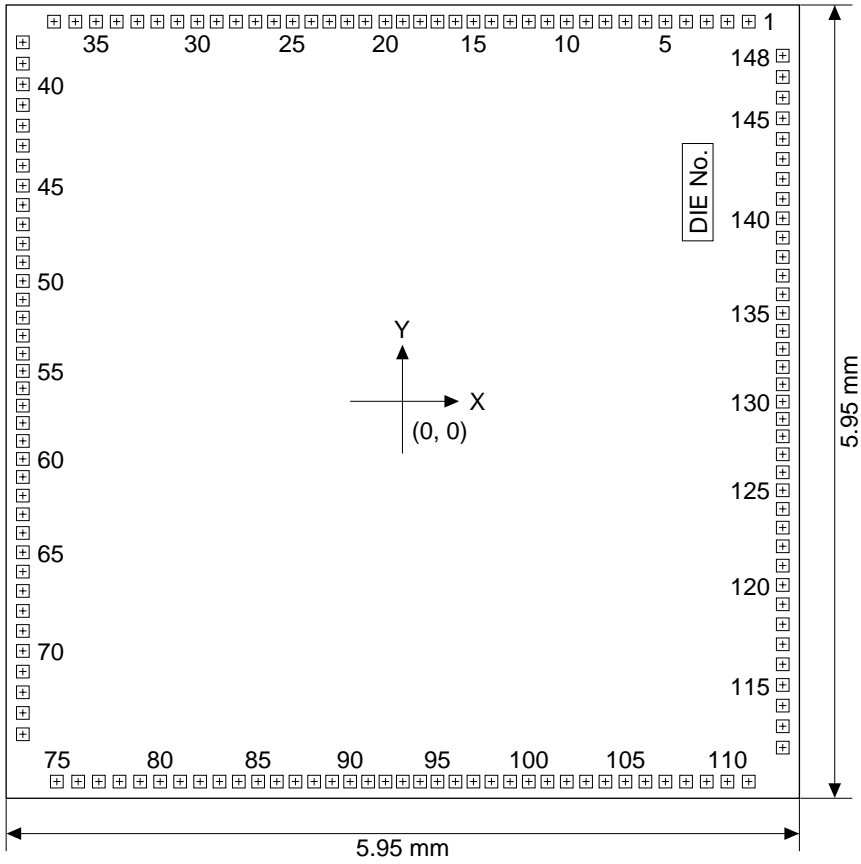

Chip thickness: 0.4 mm  
Pad opening: 95 µm

## 9.2 Pad Coordinates

Table 9.2.1 Pad coordinates (E0C88348)

(Unit: mm)

No.	Name	X	Y	No.	Name	X	Y	No.	Name	X	Y	No.	Name	X	Y		
1	COM24/SEG58	3.220	3.345	44	Vss	-3.360	3.194	87	R13/A11	-2.777	-3.345	130	SEG20	3.360	-2.783		
2	COM23/SEG59	3.005	3.345	45	OSC1	-3.360	2.950	88	R14/A12	-2.602	-3.345	131	SEG21	3.360	-2.613		
3	COM22/SEG60	2.810	3.345	46	OSC2	-3.360	2.744	89	R15/A13	-2.442	-3.345	132	SEG22	3.360	-2.453		
4	COM21/SEG61	2.635	3.345	47	TEST	-3.360	2.542	90	R16/A14	-2.287	-3.345	133	SEG23	3.360	-2.298		
5	COM20/SEG62	2.475	3.345	48	RESET	-3.360	2.382	91	R17/A15	-2.132	-3.345	134	SEG24	3.360	-2.143		
6	COM19/SEG63	2.320	3.345	49	MCU/MPU	-3.360	2.227	92	R20/A16	-1.977	-3.345	135	SEG25	3.360	-1.988		
7	COM18/SEG64	2.165	3.345	50	K11/BREQ	-3.360	2.072	93	R21/A17	-1.827	-3.345	136	SEG26	3.360	-1.838		
8	COM17/SEG65	2.010	3.345	51	K10/EVIN	-3.360	1.917	94	R22/A18	-1.677	-3.345	137	SEG27	3.360	-1.688		
9	COM16/SEG66	1.860	3.345	52	K07	-3.360	1.743	95	R23/RD	-1.527	-3.345	138	SEG28	3.360	-1.538		
10	COM15	1.710	3.345	53	K06	-3.360	1.567	96	R24/WR	-1.382	-3.345	139	SEG29	3.360	-1.393		
11	COM14	1.560	3.345	54	K05	-3.360	1.394	97	R25/CL	-1.237	-3.345	140	SEG30	3.360	-1.248		
12	COM13	1.415	3.345	55	K04	-3.360	1.221	98	R26/FR	-1.092	-3.345	141	SEG31	3.360	-1.103		
13	COM12	1.270	3.345	56	K03	-3.360	1.043	99	R27/TOUT	-0.952	-3.345	142	SEG32	3.360	-0.963		
14	COM11	1.125	3.345	57	K02	-3.360	0.891	100	R30/CE0	-0.812	-3.345	143	SEG33	3.360	-0.823		
15	COM10	0.985	3.345	58	K01	-3.360	0.737	101	R31/CE1	-0.672	-3.345	144	SEG34	3.360	-0.683		
16	COM9	0.845	3.345	59	K00	-3.360	0.596	102	R32/CE2	-0.537	-3.345	145	SEG35	3.360	-0.548		
17	COM8	0.705	3.345	60	P17/CMPP1	-3.360	0.459	103	R33/CE3	-0.402	-3.345	146	SEG36	3.360	-0.413		
18	COM7	0.570	3.345	61	P16/CMPP1	-3.360	0.317	104	R34/FOUT	-0.267	-3.345	147	SEG37	3.360	-0.278		
19	COM6	0.435	3.345	62	P15/CMPP0	-3.360	0.174	105	R35	-0.137	-3.345	148	-	*	3.350	-0.151	
20	COM5	0.300	3.345	63	P14/CMPP0	-3.360	0.022	106	R36	-0.007	-3.345	149	-	*	3.350	-0.021	
21	-	*	0.170	3.335	64	P13/SRDY	-3.360	-0.131	107	R37	0.123	-3.345	150	-	*	3.350	0.109
22	-	*	0.040	3.335	65	P12/SCLK	-3.360	-0.299	108	R50/BZ	0.253	-3.345	151	SEG38	3.360	0.241	
23	-	*	-0.090	3.335	66	P11/SOUT	-3.360	-0.434	109	R51/BACK	0.388	-3.345	152	SEG39	3.360	0.376	
24	-	*	-0.220	3.335	67	P10/SIN	-3.360	-0.569	110	SEG0	0.523	-3.345	153	SEG40	3.360	0.511	
25	COM4	-0.354	3.345	68	P07/D7	-3.360	-0.704	111	SEG1	0.658	-3.345	154	SEG41	3.360	0.646		
26	COM3	-0.489	3.345	69	P06/D6	-3.360	-0.844	112	SEG2	0.798	-3.345	155	SEG42	3.360	0.786		
27	COM2	-0.624	3.345	70	P05/D5	-3.360	-0.984	113	SEG3	0.938	-3.345	156	SEG43	3.360	0.926		
28	COM1	-0.764	3.345	71	P04/D4	-3.360	-1.124	114	SEG4	1.078	-3.345	157	SEG44	3.360	1.066		
29	COM0	-0.904	3.345	72	P03/D3	-3.360	-1.269	115	SEG5	1.223	-3.345	158	SEG45	3.360	1.211		
30	CE	-1.044	3.345	73	P02/D2	-3.360	-1.414	116	SEG6	1.368	-3.345	159	SEG46	3.360	1.356		
31	CD	-1.189	3.345	74	P01/D1	-3.360	-1.559	117	SEG7	1.513	-3.345	160	SEG47	3.360	1.501		
32	CC	-1.334	3.345	75	P00/D0	-3.360	-1.709	118	SEG8	1.663	-3.345	161	SEG48	3.360	1.651		
33	CB	-1.479	3.345	76	R00/A0	-3.360	-1.859	119	SEG9	1.813	-3.345	162	SEG49	3.360	1.801		
34	CA	-1.629	3.345	77	R01/A1	-3.360	-2.009	120	SEG10	1.963	-3.345	163	SEG50	3.360	1.951		
35	Vc5	-1.779	3.345	78	R02/A2	-3.360	-2.164	121	SEG11	2.118	-3.345	164	COM31/SEG51	3.360	2.106		
36	Vc4	-1.929	3.345	79	R03/A3	-3.360	-2.319	122	SEG12	2.273	-3.345	165	COM30/SEG52	3.360	2.261		
37	Vc3	-2.084	3.345	80	R04/A4	-3.360	-2.474	123	SEG13	2.428	-3.345	166	COM29/SEG53	3.360	2.416		
38	Vc2	-2.239	3.345	81	R05/A5	-3.360	-2.634	124	SEG14	2.588	-3.345	167	COM28/SEG54	3.360	2.576		
39	Vc1	-2.394	3.345	82	R06/A6	-3.360	-2.804	125	SEG15	2.763	-3.345	168	COM27/SEG55	3.360	2.746		
40	OSC3	-2.554	3.345	83	R07/A7	-3.360	-2.989	126	SEG16	2.958	-3.345	169	COM26/SEG56	3.360	2.931		
41	OSC4	-2.729	3.345	84	R10/A8	-3.360	-3.189	127	SEG17	3.173	-3.345	170	COM25/SEG57	3.360	3.131		
42	Vd1	-2.984	3.345	85	R11/A9	-3.187	-3.345	128	SEG18	3.360	-3.168						
43	VdD	-3.209	3.345	86	R12/A10	-2.972	-3.345	129	SEG19	3.360	-2.968						

\* Pads (No.21–24 and 148–150) are used for the IC shipment test, so you should not bond them.

9 PAD LAYOUT

Table 9.2.2 Pad coordinates (E0C88317)

(Unit: mm)

No.	Name	X	Y	No.	Name	X	Y	No.	Name	X	Y	No.	Name	X	Y
1	COM25/SEG57	2.665	2.682	42	OSC1	-2.729	2.657	83	R12/A10	-2.600	-2.682	124	SEG17	2.729	-2.543
2	COM24/SEG58	2.535	2.682	43	OSC2	-2.729	2.527	84	R13/A11	-2.470	-2.682	125	SEG18	2.729	-2.413
3	COM23/SEG59	2.405	2.682	44	TEST	-2.729	2.397	85	R14/A12	-2.340	-2.682	126	SEG19	2.729	-2.283
4	COM22/SEG60	2.275	2.682	45	RESET	-2.729	2.267	86	R15/A13	-2.210	-2.682	127	SEG20	2.729	-2.153
5	COM21/SEG61	2.145	2.682	46	MCU/MPU	-2.729	2.137	87	R16/A14	-2.080	-2.682	128	SEG21	2.729	-2.023
6	COM20/SEG62	2.015	2.682	47	K11/BREQ	-2.729	2.007	88	R17/A15	-1.950	-2.682	129	SEG22	2.729	-1.893
7	COM19/SEG63	1.885	2.682	48	K10/EVIN	-2.729	1.877	89	R20/A16	-1.820	-2.682	130	SEG23	2.729	-1.763
8	COM18/SEG64	1.755	2.682	49	K07	-2.729	1.747	90	R21/A17	-1.690	-2.682	131	SEG24	2.729	-1.633
9	COM17/SEG65	1.625	2.682	50	K06	-2.729	1.617	91	R22/A18	-1.560	-2.682	132	SEG25	2.729	-1.503
10	COM16/SEG66	1.495	2.682	51	K05	-2.729	1.487	92	R23/RD	-1.430	-2.682	133	SEG26	2.729	-1.373
11	COM15	1.365	2.682	52	K04	-2.729	1.357	93	R24/WR	-1.300	-2.682	134	SEG27	2.729	-1.243
12	COM14	1.235	2.682	53	K03	-2.729	1.227	94	R25/CL	-1.170	-2.682	135	SEG28	2.729	-1.113
13	COM13	1.105	2.682	54	K02	-2.729	1.097	95	R26/FR	-1.040	-2.682	136	SEG29	2.729	-983
14	COM12	975	2.682	55	K01	-2.729	967	96	R27/TOUT	-910	-2.682	137	SEG30	2.729	-853
15	COM11	845	2.682	56	K00	-2.729	837	97	R30/CE0	-780	-2.682	138	SEG31	2.729	-723
16	COM10	715	2.682	57	P17/CMPP1	-2.729	707	98	R31/CE1	-650	-2.682	139	SEG32	2.729	-593
17	COM9	585	2.682	58	P16/CMPP1	-2.729	577	99	R32/CE2	-520	-2.682	140	SEG33	2.729	-463
18	COM8	455	2.682	59	P15/CMPP0	-2.729	447	100	R33/CE3	-390	-2.682	141	SEG34	2.729	-333
19	COM7	325	2.682	60	P14/CMPP0	-2.729	317	101	R34/FOUT	-260	-2.682	142	SEG35	2.729	-203
20	COM6	195	2.682	61	P13/SRDY	-2.729	187	102	R35	-130	-2.682	143	SEG36	2.729	-73
21	COM5	65	2.682	62	P12/SCLK	-2.729	57	103	R36	0	-2.682	144	SEG37	2.729	57
22	COM4	-65	2.682	63	P11/SOUT	-2.729	-73	104	R37	130	-2.682	145	SEG38	2.729	187
23	COM3	-195	2.682	64	P10/SIN	-2.729	-203	105	R50/BZ	260	-2.682	146	SEG39	2.729	317
24	COM2	-325	2.682	65	P07/D7	-2.729	-333	106	R51/BACK	390	-2.682	147	SEG40	2.729	447
25	COM1	-455	2.682	66	P06/D6	-2.729	-463	107	SEG0	520	-2.682	148	SEG41	2.729	577
26	COM0	-585	2.682	67	P05/D5	-2.729	-593	108	SEG1	650	-2.682	149	SEG42	2.729	707
27	CE	-715	2.682	68	P04/D4	-2.729	-723	109	SEG2	780	-2.682	150	SEG43	2.729	837
28	CD	-845	2.682	69	P03/D3	-2.729	-853	110	SEG3	910	-2.682	151	SEG44	2.729	967
29	CC	-975	2.682	70	P02/D2	-2.729	-983	111	SEG4	1.040	-2.682	152	SEG45	2.729	1.097
30	CB	-1.105	2.682	71	P01/D1	-2.729	-1.113	112	SEG5	1.170	-2.682	153	SEG46	2.729	1.227
31	CA	-1.234	2.682	72	P00/D0	-2.729	-1.243	113	SEG6	1.300	-2.682	154	SEG47	2.729	1.357
32	Vc5	-1.365	2.682	73	R00/A0	-2.729	-1.373	114	SEG7	1.430	-2.682	155	SEG48	2.729	1.487
33	Vc4	-1.495	2.682	74	R01/A1	-2.729	-1.503	115	SEG8	1.560	-2.682	156	SEG49	2.729	1.617
34	Vc3	-1.625	2.682	75	R02/A2	-2.729	-1.633	116	SEG9	1.690	-2.682	157	SEG50	2.729	1.747
35	Vc2	-1.755	2.682	76	R03/A3	-2.729	-1.763	117	SEG10	1.820	-2.682	158	COM31/SEG51	2.729	1.877
36	Vc1	-1.885	2.682	77	R04/A4	-2.729	-1.893	118	SEG11	1.950	-2.682	159	COM30/SEG52	2.729	2.007
37	OSC3	-2.015	2.682	78	R05/A5	-2.729	-2.023	119	SEG12	2.080	-2.682	160	COM29/SEG53	2.729	2.137
38	OSC4	-2.145	2.682	79	R06/A6	-2.729	-2.153	120	SEG13	2.210	-2.682	161	COM28/SEG54	2.729	2.267
39	Vd1	-2.275	2.682	80	R07/A7	-2.729	-2.283	121	SEG14	2.340	-2.682	162	COM27/SEG55	2.729	2.397
40	VdD	-2.405	2.682	81	R10/A8	-2.729	-2.413	122	SEG15	2.470	-2.682	163	COM26/SEG56	2.729	2.527
41	VSS	-2.535	2.682	82	R11/A9	-2.729	-2.543	123	SEG16	2.600	-2.682				

Table 9.2.3 Pad coordinates (E0C88316)

(Unit: mm)

No.	Name	X	Y	No.	Name	X	Y	No.	Name	X	Y	No.	Name	X	Y
1	COM24/SEG58	3.150	3.300	44	VSS	-3.300	3.150	87	R11/A9	-3.150	-3.300	130	SEG18	3.300	-3.150
2	COM23/SEG59	2.950	3.300	45	OSC1	-3.300	2.950	88	R12/A10	-2.950	-3.300	131	SEG19	3.300	-2.950
3	COM22/SEG60	2.765	3.300	46	OSC2	-3.300	2.765	89	R13/A11	-2.765	-3.300	132	SEG20	3.300	-2.765
4	COM21/SEG61	2.595	3.300	47	TEST	-3.300	2.595	90	R14/A12	-2.595	-3.300	133	SEG21	3.300	-2.595
5	COM20/SEG62	2.435	3.300	48	RESET	-3.300	2.435	91	R15/A13	-2.435	-3.300	134	SEG22	3.300	-2.435
6	COM19/SEG63	2.280	3.300	49	MCU/MPU	-3.300	2.280	92	R16/A14	-2.280	-3.300	135	SEG23	3.300	-2.280
7	COM18/SEG64	2.125	3.300	50	K11/BREQ	-3.300	2.125	93	R17/A15	-2.125	-3.300	136	SEG24	3.300	-2.125
8	COM17/SEG65	1.970	3.300	51	K10/EVIN	-3.300	1.970	94	R20/A16	-1.970	-3.300	137	SEG25	3.300	-1.970
9	COM16/SEG66	1.820	3.300	52	K07	-3.300	1.820	95	R21/A17	-1.820	-3.300	138	SEG26	3.300	-1.820
10	COM15	1.670	3.300	53	K06	-3.300	1.670	96	R22/A18	-1.670	-3.300	139	SEG27	3.300	-1.670
11	COM14	1.520	3.300	54	K05	-3.300	1.520	97	R23/RD	-1.520	-3.300	140	SEG28	3.300	-1.520
12	COM13	1.375	3.300	55	K04	-3.300	1.375	98	R24/WR	-1.375	-3.300	141	SEG29	3.300	-1.375
13	COM12	1.230	3.300	56	K03	-3.300	1.230	99	R25/CL	-1.230	-3.300	142	SEG30	3.300	-1.230
14	COM11	1.085	3.300	57	K02	-3.300	1.085	100	R26/FR	-1.085	-3.300	143	SEG31	3.300	-1.085
15	COM10	0.945	3.300	58	K01	-3.300	0.945	101	R27/TOUT	-0.945	-3.300	144	SEG32	3.300	-0.945
16	COM9	0.805	3.300	59	K00	-3.300	0.805	102	R30/CE0	-0.805	-3.300	145	SEG33	3.300	-0.805
17	COM8	0.665	3.300	60	P17/CMPP1	-3.300	0.665	103	R31/CE1	-0.665	-3.300	146	SEG34	3.300	-0.665
18	COM7	0.530	3.300	61	P16/CMPP1	-3.300	0.530	104	R32/CE2	-0.530	-3.300	147	SEG35	3.300	-0.530
19	COM6	0.395	3.300	62	P15/CMPP0	-3.300	0.395	105	R33/CE3	-0.395	-3.300	148	SEG36	3.300	-0.395
20	COM5	0.260	3.300	63	P14/CMPP0	-3.300	0.260	106	R34/FOUT	-0.260	-3.300	149	SEG37	3.300	-0.260
21	— *	0.130	3.290	64	P13/SRDY	-3.300	0.130	107	R35	-0.130	-3.300	150	— *	3.300	-0.130
22	— *	0.000	3.290	65	— *	-3.300	0.000	108	R36	0.000	-3.300	151	— *	3.300	0.000
23	— *	-0.130	3.290	66	— *	-3.300	-0.130	109	R37	0.130	-3.300	152	— *	3.300	0.130
24	— *	-0.260	3.290	67	P12/SCLK	-3.300	-0.260	110	R50/BZ	0.260	-3.300	153	SEG38	3.300	0.260
25	COM4	-0.395	3.300	68	P11/SOUT	-3.300	-0.395	111	R51/BACK	0.395	-3.300	154	SEG39	3.300	0.395
26	COM3	-0.530	3.300	69	P10/SIN	-3.300	-0.530	112	SEG0	0.530	-3.300	155	SEG40	3.300	0.530
27	COM2	-0.665	3.300	70	P07/D7	-3.300	-0.665	113	SEG1	0.665	-3.300	156	SEG41	3.300	0.665
28	COM1	-0.805	3.300	71	P06/D6	-3.300	-0.805	114	SEG2	0.805	-3.300	157	SEG42	3.300	0.805
29	COM0	-0.945	3.300	72	P05/D5	-3.300	-0.945	115	SEG3	0.945	-3.300	158	SEG43	3.300	0.945
30	CE	-1.085	3.300	73	P04/D4	-3.300	-1.085	116	SEG4	1.085	-3.300	159	SEG44	3.300	1.085
31	CD	-1.230	3.300	74	P03/D3	-3.300	-1.230	117	SEG5	1.230	-3.300	160	SEG45	3.300	1.230
32	CC	-1.375	3.300	75	P02/D2	-3.300	-1.375	118	SEG6	1.375	-3.300	161	SEG46	3.300	1.375
33	CB	-1.520	3.300	76	P01/D1	-3.300	-1.520	119	SEG7	1.520	-3.300	162	SEG47	3.300	1.520
34	CA	-1.670	3.300	77	P00/D0	-3.300	-1.670	120	SEG8	1.670	-3.300	163	SEG48	3.300	1.670
35	Vc5	-1.820	3.300	78	R00/A0	-3.300	-1.820	121	SEG9	1.820	-3.300	164	SEG49	3.300	1.820
36	Vc4	-1.970	3.300	79	R01/A1	-3.300	-1.970	122	SEG10	1.970	-3.300	165	SEG50	3.300	1.970
37	Vc3	-2.125	3.300	80	R02/A2	-3.300	-2.125	123	SEG11	2.125	-3.300	166	COM31/SEG51	3.300	2.125
38	Vc2	-2.280	3.300	81	R03/A3	-3.300	-2.280	124	SEG12	2.280	-3.300	167	COM30/SEG52	3.300	2.280
39	Vc1	-2.435	3.300	82	R04/A4	-3.300	-2.435	125	SEG13	2.435	-3.300	168	COM29/SEG53	3.300	2.435
40	OSC3	-2.595	3.300	83	R05/A5	-3.300	-2.595	126	SEG14	2.595	-3.300	169	COM28/SEG54	3.300	2.595
41	OSC4	-2.765	3.300	84	R06/A6	-3.300	-2.765	127	SEG15	2.765	-3.300	170	COM27/SEG55	3.300	2.765
42	Vd1	-2.950	3.300	85	R07/A7	-3.300	-2.950	128	SEG16	2.950	-3.300	171	COM26/SEG56	3.300	2.950
43	VDD	-3.150	3.300	86	R10/A8	-3.300	-3.150	129	SEG17	3.150	-3.300	172	COM25/SEG57	3.300	3.150

\* Pads (No.21–24, 65–66 and 150–152) are used for the IC shipment test, so you should not bond them.

## 9 PAD LAYOUT

Table 9.2.4 Pad coordinates (E0C88308)

(Unit: mm)

No.	Name	X	Y	No.	Name	X	Y	No.	Name	X	Y	No.	Name	X	Y
1	COM22/SEG50	2.595	2.850	38	VSS	-2.850	2.695	75	R06/A6	-2.595	-2.850	112	SEG13	2.850	-2.595
2	COM21/SEG51	2.435	2.850	39	OSC1	-2.850	2.535	76	R07/A7	-2.435	-2.850	113	SEG14	2.850	-2.435
3	COM20/SEG52	2.280	2.850	40	OSC2	-2.850	2.380	77	R10/A8	-2.280	-2.850	114	SEG15	2.850	-2.280
4	COM19/SEG53	2.125	2.850	41	TEST	-2.850	2.225	78	R11/A9	-2.125	-2.850	115	SEG16	2.850	-2.125
5	COM18/SEG54	1.970	2.850	42	RESET	-2.850	2.070	79	R12/A10	-1.970	-2.850	116	SEG17	2.850	-1.970
6	COM17/SEG55	1.820	2.850	43	MCU/MPU	-2.850	1.920	80	R13/A11	-1.820	-2.850	117	SEG18	2.850	-1.820
7	COM16/SEG56	1.670	2.850	44	K10/EVIN	-2.850	1.770	81	R14/A12	-1.670	-2.850	118	SEG19	2.850	-1.670
8	COM15	1.520	2.850	45	K07	-2.850	1.620	82	R15/A13	-1.520	-2.850	119	SEG20	2.850	-1.520
9	COM14	1.375	2.850	46	K06	-2.850	1.475	83	R16/A14	-1.375	-2.850	120	SEG21	2.850	-1.375
10	COM13	1.230	2.850	47	K05	-2.850	1.330	84	R17/A15	-1.230	-2.850	121	SEG22	2.850	-1.230
11	COM12	1.085	2.850	48	K04	-2.850	1.185	85	R20/A16	-1.085	-2.850	122	SEG23	2.850	-1.085
12	COM11	0.945	2.850	49	K03	-2.850	1.045	86	R21/A17	-0.945	-2.850	123	SEG24	2.850	-0.945
13	COM10	0.805	2.850	50	K02	-2.850	0.905	87	R22/A18	-0.805	-2.850	124	SEG25	2.850	-0.805
14	COM9	0.665	2.850	51	K01	-2.850	0.765	88	R23/RD	-0.665	-2.850	125	SEG26	2.850	-0.665
15	COM8	0.530	2.850	52	K00	-2.850	0.630	89	R24/WR	-0.530	-2.850	126	SEG27	2.850	-0.530
16	COM7	0.395	2.850	53	P17/CMPP1	-2.850	0.495	90	R25/CL	-0.395	-2.850	127	SEG28	2.850	-0.395
17	COM6	0.260	2.850	54	P16/CMPP1	-2.850	0.360	91	R26/FR	-0.260	-2.850	128	SEG29	2.850	-0.260
18	COM5	0.130	2.850	55	P15/CMPP0	-2.850	0.230	92	R27/TOUT	-0.130	-2.850	129	SEG30	2.850	-0.130
19	COM4	0.000	2.850	56	P14/CMPP0	-2.850	0.100	93	R30/CE0	0.000	-2.850	130	SEG31	2.850	0.000
20	COM3	-0.130	2.850	57	P13/SRDY	-2.850	-0.030	94	R31/CE1	0.130	-2.850	131	SEG32	2.850	0.130
21	COM2	-0.281	2.850	58	P12/SCLK	-2.850	-0.160	95	R32/CE2	0.260	-2.850	132	SEG33	2.850	0.260
22	COM1	-0.416	2.850	59	P11/SOUT	-2.850	-0.295	96	R33/CE3	0.395	-2.850	133	SEG34	2.850	0.395
23	COM0	-0.551	2.850	60	P10/SIN	-2.850	-0.430	97	R34/FOUT	0.530	-2.850	134	SEG35	2.850	0.530
24	CE	-0.686	2.850	61	P07/D7	-2.850	-0.565	98	R50/BZ	0.665	-2.850	135	SEG36	2.850	0.665
25	CD	-0.826	2.850	62	P06/D6	-2.850	-0.705	99	SEG0	0.805	-2.850	136	SEG37	2.850	0.805
26	CC	-0.966	2.850	63	P05/D5	-2.850	-0.845	100	SEG1	0.945	-2.850	137	SEG38	2.850	0.945
27	CB	-1.106	2.850	64	P04/D4	-2.850	-0.985	101	SEG2	1.085	-2.850	138	SEG39	2.850	1.085
28	CA	-1.251	2.850	65	P03/D3	-2.850	-1.130	102	SEG3	1.230	-2.850	139	SEG40	2.850	1.230
29	Vc5	-1.396	2.850	66	P02/D2	-2.850	-1.275	103	SEG4	1.375	-2.850	140	COM31/SEG41	2.850	1.375
30	Vc4	-1.541	2.850	67	P01/D1	-2.850	-1.420	104	SEG5	1.520	-2.850	141	COM30/SEG42	2.850	1.520
31	Vc3	-1.691	2.850	68	P00/D0	-2.850	-1.570	105	SEG6	1.670	-2.850	142	COM29/SEG43	2.850	1.670
32	Vc2	-1.841	2.850	69	R00/A0	-2.850	-1.720	106	SEG7	1.820	-2.850	143	COM28/SEG44	2.850	1.820
33	Vc1	-1.991	2.850	70	R01/A1	-2.850	-1.870	107	SEG8	1.970	-2.850	144	COM27/SEG45	2.850	1.970
34	OSC3	-2.146	2.850	71	R02/A2	-2.850	-2.025	108	SEG9	2.125	-2.850	145	COM26/SEG46	2.850	2.125
35	OSC4	-2.301	2.850	72	R03/A3	-2.850	-2.180	109	SEG10	2.280	-2.850	146	COM25/SEG47	2.850	2.280
36	VD1	-2.456	2.850	73	R04/A4	-2.850	-2.335	110	SEG11	2.435	-2.850	147	COM24/SEG48	2.850	2.435
37	VDD	-2.616	2.850	74	R05/A5	-2.850	-2.495	111	SEG12	2.595	-2.850	148	COM23/SEG49	2.850	2.595

# 10 PRECAUTIONS ON MOUNTING

## <Oscillation Circuit>

- Oscillation characteristics change depending on conditions (board pattern, components used, etc.).

In particular, when a ceramic oscillator or crystal oscillator is used, use the oscillator manufacturer's recommended values for constants such as capacitance and resistance.

- Disturbances of the oscillation clock due to noise may cause a malfunction. Consider the following points to prevent this:
  - (1) Components which are connected to the OSC1, OSC2, OSC3 and OSC4 terminals, such as oscillators, resistors and capacitors, should be connected in the shortest line.
  - (2) As shown in the right hand figure, make a Vss pattern as large as possible at circumscription of the OSC1, OSC2, OSC3 and OSC4 terminals and the components connected to these terminals. Furthermore, do not use this Vss pattern for any purpose other than the oscillation system.

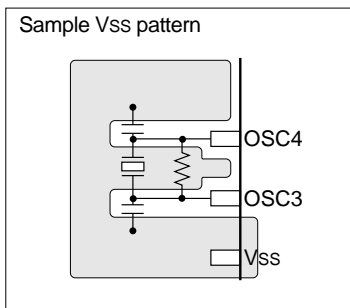

- (3) When supplying an external clock to the OSC1 (OSC3) terminal, the clock source should be connected to the OSC1 (OSC3) terminal in the shortest line. Furthermore, do not connect anything else to the OSC2 (OSC4) terminal.
- In order to prevent unstable operation of the oscillation circuit due to current leak between OSC1 (OSC3) and VDD, please keep enough distance between OSC1 (OSC3) and VDD or other signals on the board pattern.

## <Reset Circuit>

- The power-on reset signal which is input to the  $\overline{\text{RESET}}$  terminal changes depending on conditions (power rise time, components used, board pattern, etc.).

Decide the time constant of the capacitor and resistor after enough tests have been completed with the application product.

When the built-in pull-up resistor is added to the  $\overline{\text{RESET}}$  terminal by mask option, take into consideration dispersion of the resistance for setting the constant.

- In order to prevent any occurrences of unnecessary resetting caused by noise during operating, components such as capacitors and resistors should be connected to the  $\overline{\text{RESET}}$  terminal in the shortest line.

## <Power Supply Circuit>

- Sudden power supply variation due to noise may cause malfunction. Consider the following points to prevent this:
  - (1) The power supply should be connected to the VDD and Vss terminals with patterns as short and large as possible.
  - (2) When connecting between the VDD and Vss terminals with a bypass capacitor, the terminals should be connected as short as possible.

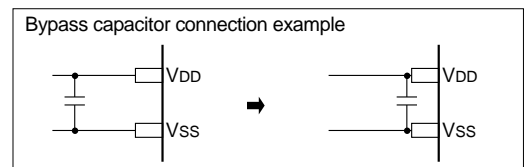

- (3) Components which are connected to the VD1, VC1-VC5 and CA-CE terminals, such as capacitors, should be connected in the shortest line. In particular, the VC1-VC5 voltages affect the display quality.
- Do not connect anything to the VC1-VC5 and CA-CE terminals when the LCD driver is not used.

<Arrangement of Signal Lines>

- In order to prevent generation of electromagnetic induction noise caused by mutual inductance, do not arrange a large current signal line near the circuits that are sensitive to noise such as the oscillation unit and analog unit.
- When a signal line is parallel with a high-speed line in long distance or intersects a high-speed line, noise may be generated by mutual interference between the signals and it may cause a malfunction.

Do not arrange a high-speed signal line especially near circuits that are sensitive to noise such as the oscillation unit and analog unit.

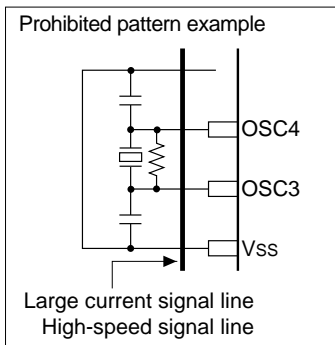

<Precautions for Visible Radiation (when bare chip is mounted)>

- Visible radiation causes semiconductor devices to change the electrical characteristics. It may cause this IC to malfunction. When developing products which use this IC, consider the following precautions to prevent malfunctions caused by visible radiations.
- (1) Design the product and implement the IC on the board so that it is shielded from visible radiation in actual use.
  - (2) The inspection process of the product needs an environment that shields the IC from visible radiation.
  - (3) As well as the face of the IC, shield the back and side too.



***II*** ***E0C88348/317/316/308***  
***Technical Software***

# Contents

<b>PREFACE</b> .....	<b>II-1</b>
Description	
Notes for Program Example Use	
<b>1 SYSTEM INITIALIZATION</b> .....	<b>II-2</b>
Initialization for E0C88316 single chip mode	
<b>2 SYSTEM CONTROLLER AND BUS CONTROL</b> .....	<b>II-4</b>
(1) E0C88316 Single chip mode	
(2) E0C88308 MCU Expanded 64K mode	
(3) E0C88316 MCU Expanded 64K mode	
(4) E0C88316 MPU Expanded 64K mode	
(5) E0C88316 MPU Expanded 512K maximum mode	
<b>3 WATCHDOG TIMER</b> .....	<b>II-9</b>
(1) Watchdog timer reset	
(2) Watchdog timer (NMI) interrupt processing	
<b>4 OSCILLATION CIRCUIT</b> .....	<b>II-11</b>
(1) Switching from OSC1 to OSC3	
(2) Switching from OSC3 to OSC1	
<b>5 INPUT PORTS (K PORTS)</b> .....	<b>II-14</b>
(1) Data reading from normal input port (K port)	
(2) Key scanning on 8 x 2 key matrix	
(3) Interrupt condition setting and interrupt processing for input port (K port)	
<b>6 OUTPUT PORTS (R PORTS)</b> .....	<b>II-21</b>
(1) Normal DC output	
(2) High impedance output control	
(3) FOUT output control	
<b>7 I/O PORTS (P PORTS)</b> .....	<b>II-27</b>
(1) Normal data input/output of I/O port	
(2) Scan for 2 x 2 switch matrix	
<b>8 SERIAL INTERFACE 1 (CLOCK SYNCHRONOUS INTERFACE)</b> .....	<b>II-33</b>
(1) Initialization for clock synchronous serial interface (master mode)	
(2) Receiving of clock synchronous serial interface (master mode)	
(3) Transmitting of clock synchronous serial interface (master mode)	
<b>9 SERIAL INTERFACE 2 (ASYNCHRONOUS INTERFACE)</b> .....	<b>II-42</b>
(1) Initialization for asynchronous serial interface (8-bit mode)	
(2) Receiving of asynchronous serial interface (8-bit mode)	
(3) Transmitting of asynchronous serial interface (8-bit mode)	
<b>10 CLOCK TIMER</b> .....	<b>II-53</b>
(1) Initialization for clock timer	
(2) Clock timer interrupt processing	
<b>11 STOPWATCH TIMER</b> .....	<b>II-58</b>
(1) Initialization for stopwatch timer	
(2) Stopwatch timer interrupt processing	

**12 PROGRAMMABLE TIMER ..... II-63**  
 (1) Initialization and interrupt processing for 8-bit reload timer (two channels)  
 (2) Initialization and interrupt processing for 16-bit one-shot timer (one channel)  
 (3) Initialization and interrupt processing for 8-bit event counter  
 (4) Initialization and interrupt processing for 16-bit pulse width measurement timer  
 (5) 16-bit reload timer pulse output

**13 LCD CONTROLLER ..... II-86**  
 (1) Initialization for LCD controller  
 (2) Display control

**14 SOUND GENERATOR ..... II-91**  
 (1) Initialization for sound generator  
 (2) Normal buzzer output  
 (3) Buzzer output with digital envelope  
 (4) One-shot buzzer output

**15 ANALOG COMPARATOR ..... II-96**  
 (1) Initialization for analog comparator  
 (2) Data reading for analog comparator

**16 SVD (SUPPLY VOLTAGE DETECTION) CIRCUIT ..... II-98**  
 (1) Supply voltage detection in 1/4 Hz auto sampling mode  
 (2) Supply voltage detection in continuously sampling mode

**17 INTERRUPT (EXCEPTION) PROCESSING ..... II-100**  
 (1) Interrupt level setting and enables interrupt  
 (2) Zero division exception processing  
 (3) Watchdog timer ( $\overline{NMI}$ ) interrupt processing  
 (4) Interrupt processing for peripheral circuit

**18 EXPANDED MODE ..... II-108**  
 (1) Access for program memory outside logical space  
 (2) Data block transfer between pages  
 (3) Access for data outside page

**Appendix A Table of Input/Output Port Terminals ..... II-111**

**Appendix B Instruction List ..... II-113**

**Appendix C Programming Notes ..... II-130**

# PREFACE

In this part, example of a control programs for each peripheral circuit are described. Basic initialization and control routines are shown in the program examples use a relocatable method and are based on the assumption that the cross assembler asm88 for the E0C88 Family is being used. When you create an application program referring to these examples, use them after completion of the program by adding the necessary functions.

## Description

Program examples are shown by each peripheral circuit or function, according to the following items.

**I/O MAP** Indicates the I/O memory map that controls the peripheral circuit. See Part I in this manual, "E0C88348/317/316/308 Technical Hardware", for details of the control registers and operation.

**Specification** Indicates the purpose, function, etc., of the example routine.

**Flowchart** Indicates a flowchart of the example.

**Note** Indicates matters that require attention when using the example routine and for programming of the peripheral circuit.

**Source List** A source code listing using the relocatable method in assembly language. See the "E0C88 Core CPU Manual" for details of the instructions and the "E0C88 Family Structured Assembler Manual" for the assembly language and the format of the source list.

## Notes for Program Example Use

Take the following precautions when reading this manual and using the described routines:

- (1) Each program example has been modularized as a low-level routine that controls hardware directly, and examples such as a concrete application have not been included. For a routine to be added by the user, an external declaration with a label such as "user\_program" should be made and the program will branch to the label. Because the name "user\_program" is not very descriptive, you should modify the label name to reflect its function.
- (2) In the program examples, 8-bit absolute addressing has been used for I/O memory access. Consequently, the program loads the upper 8 bits (0FFH) of the I/O memory base address (00FF00H) into the BR register. This part in the flowchart is described as (BR setting) and it is set in each program example. If you use another addressing mode, rewriting this part is necessary.
- (3) These routines do not specify bank or page. When using in the expanded mode, set the bank and page if necessary.
- (4) Input, output and I/O port terminals of the E0C88316 are shared the a bus and special output, and these functions are set by software. Be aware that the port configuration will be changed by these setting. Refer to the terminal configuration tables according to the mode and special output settings which have been mentioned in the "Appendix".
- (5) Unary operators set in the asm88 cross assembler have been used for the program examples. These unary operators get the values below from a constant or a label operand.
  - low ... Presents the lower 8 bits of the expression.
  - high .. Returns the upper 8 bits of a 16-bit expression.
  - boc ... Calculates a bank value from the physical address.
  - loc .... Calculates a logical address in a bank from the physical address.
  - pod .. Calculates a page value from the physical address.
  - lod .... Calculates a logical address in a page from the physical address.
- (6) Seiko Epson assumes no responsibility for any consequences arising from the use of the programs described.

**Note:** *The program examples are created for the E0C88316. Since there are some differences in the built-in ROM/RAM capacity, number of input ports, output ports and LCD drive segments, and bus authority release function of the E0C88348/317/308, it is necessary to modify the settings according to the model to be used.*

# 1 SYSTEM INITIALIZATION

## I/O Map

Refer to the peripheral circuit descriptions in this manual.

Model	Internal ROM	Internal RAM	Input port	Output port*1	LCD segment*2	Bus authority release function
<b>E0C88348</b>	48K bytes	2K bytes	10 bits	9 bits	1,632 (Max.)	Available
<b>E0C88317</b>	16K bytes	2K bytes	10 bits	9 bits	1,632 (Max.)	Available
<b>E0C88316</b>	16K bytes	2K bytes	10 bits	9 bits	1,632 (Max.)	Available
<b>E0C88308</b>	8K bytes	256 bytes	9 bits	5 bits	1,312 (Max.)	Not available

\*1 The terminals common to the external bus are excluded.

\*2 Maximum number of drive segment when the 32 commons is selected.

## Specification

### Initialization for E0C88316 single chip mode

#### mainrt: Initialization for E0C88316 single chip mode

Settings of the base register, CPU mode,  $\overline{CE}$  output, stack page, stack pointer, wait and bus authority release signal and clearing of RAM (display memory included) are done sequentially.

## Flowchart

### Initialization for E0C88316 single chip mode

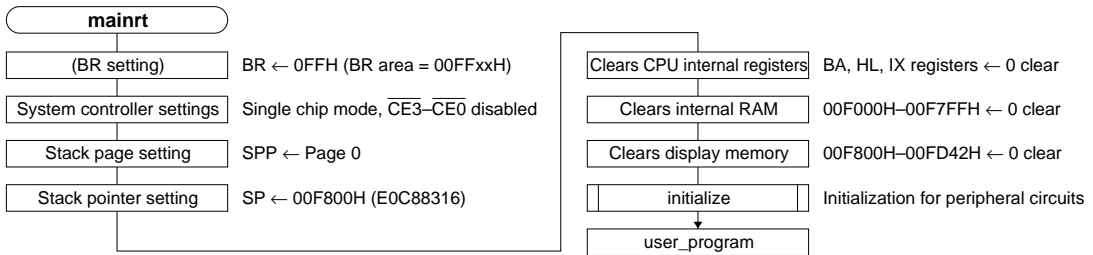

Note: Internal RAM addresses and capacity of other models are as follows:

E0C88348/317: 00F000H-00F7FFH (2K bytes)

E0C88308: 00F000H-00F0FFH (256 bytes)

## Notes

- (1) Interrupts have been set to their initial status (all disabled) except for the watchdog timer ( $\overline{NMI}$ ) interrupt which cannot be masked.
- (2) Be sure to declare the watchdog timer ( $\overline{NMI}$ ) interrupt processing routine and the vector address, regardless of whether or not the watchdog timer is used.
- (3) For peripheral circuit initialization, you must create a separate routine according to the system configuration to be used. (external call: initialize)
- (4) For the interrupt flags (I0 and I1), set them to adapt to the interrupt factor and priority level of the peripheral I/O that will be enabled.
- (5) When using the peripheral I/O interrupt, declare the front address of the peripheral I/O interrupt processing routine in a vector address corresponding to the interrupt in the order of lower and upper. (Vector address: 000006H-000023H)
- (6) Vector addresses 000026H-0000FFH can be set for software interrupts. In this case as well as the above, declare the front address of the software interrupt processing routine in a vector address of the software interrupt in the order of lower and upper.
- (7) The vector addresses 000024H and 000025H cannot be used since this is a system reserved area.
- (8) In this initialization routine example, the vector address setting and program have been allocated from 000100H for the sake of convenience.

## Source List

**Initialization for E0C88316 single chip mode**

```

        external    initialize,watchdog_reset
        external    user_program
        public      maintrt
;
reset_vector    equ    000000h                ;reset vector address
main            equ    000100h                ;program start address offset
;
br_io           equ    0ffh                  ;base reg. address (set i/o area)
mcu             equ    00ff00h                ;mcu mode system control address
spp             equ    00ff01h                ;stack pointer page address
mode           equ    00ff02h                ;mpu//mcu mode control address
;
sp_316         equ    00f800h                ;e0c88316 stack pointer top address
;
internal_ram    equ    00f000h                ;e0c88316 internal ram top address
;
lcdram_top      equ    00f800h                ;lcd ram top address
lcdram_end      equ    00fd43h                ;lcd ram end address
;
        code
intr_vectors:
        org        intr_vectors+reset_vector
        dw        maintrt                    ;initial reset program address
;
        org        intr_vectors+main
;*****
;*
;*          e0c88316 mcu single-chip mode initialize
;*
;*****
maintrt:
        ld        br,#br_io                  ;set br reg. address to 0ffxxh
        ld        [br:low mcu],#00110000b    ;single chip mode, /ce3-/ce0 disable
        ld        [br:low spp],#00h         ;set stack pointer page to 0
        ld        sp,#lod sp_316            ;satck pointer top address set
        ld        [br:low mode],#00000000b  ;set mode reg.
        ld        ba,#0000h                 ;internal reg. clear
        ld        hl,#0000h
        ld        ix,#0000h
;internal ram clear
        carl      watchdog_reset             ;watchdog timer reset ***
        ld        iy,#lod internal_ram       ;e0c88316 internal ram top address
maintrt00:
        ld        [iy],a                    ;clear data set
        inc       iy                        ;poniter increment
        cp        iy,#lod internal_ram+0800h ;internal ram end ?
        jrs      nz,maintrt00
;lcd ram clear including ignore area
        carl      watchdog_reset             ;watchdog timer reset ***
        ld        iy,#lod lcdram_top        ;lcd ram top address
maintrt01:
        ld        [iy],a                    ;clear data set
        inc       iy                        ;pointer increment
        cp        iy,#lod lcdram_end        ;lcd rasm end ?
        jrs      nz,maintrt01
;
        carl      initialize                 ;initialize i/o area ***
        jrl      user_program               ;jump user program
;
;start user program
;
        end

```

## 2 SYSTEM CONTROLLER AND BUS CONTROL

### I/O Map (MCU mode)

Address	Bit	Name	Function	1	0	SR	R/W	Comment	
00FF00 (MCU)	D7	BSMD1	Bus mode (CPU mode) <u>BSMD1 BSMD0 Mode</u> 1 1 512K (Maximum)			0	R/W		
	D6	BSMD0	1 0 512K (Minimum) 0 1 64K 0 0 Single chip			0	R/W		
	D5	CEMD1	Chip enable mode <u>CEMD1 CEMD0 Mode</u> 1 1 64K ( $\overline{CE0}$ ) 1 0 32K ( $\overline{CE0}$ , $\overline{CE1}$ )			1	R/W		Only for 64K bus mode *1
	D4	CEMD0	0 1 16K ( $\overline{CE0}$ - $\overline{CE3}$ ...E0C88308) ( $\overline{CE1}$ - $\overline{CE3}$ ...E0C88316) 0 0 8K ( $\overline{CE0}$ - $\overline{CE3}$ )			1	R/W		
	D3	CE3	$\overline{CE3}$ (R33) $\overline{CE}$ signal output Enable/Disable	$\overline{CE3}$ enable	$\overline{CE3}$ disable	0	R/W		In the Single chip mode, these setting are fixed at DC output.
	D2	CE2	$\overline{CE2}$ (R32) Enable: $\overline{CE}$ signal output	$\overline{CE2}$ enable	$\overline{CE2}$ disable	0	R/W		
	D1	CE1	$\overline{CE1}$ (R31) Disable: DC (R3x) output	$\overline{CE1}$ enable	$\overline{CE1}$ disable	0	R/W		
	D0	CE0	$\overline{CE0}$ (R30)	$\overline{CE0}$ enable	$\overline{CE0}$ disable	0	R/W		
00FF01	D7	SPP7	Stack pointer page address (MSB)	1	0	0	R/W		
	D6	SPP6		1	0	0	R/W		
	D5	SPP5	< SP page allocatable address >	1	0	0	R/W		
	D4	SPP4	• Single chip mode: only 0 page	1	0	0	R/W		
	D3	SPP3	• 64K mode: only 0 page	1	0	0	R/W		
	D2	SPP2	• 512K (min) mode: 0-27H page	1	0	0	R/W		
	D1	SPP1	• 512K (max) mode: 0-27H page	1	0	0	R/W		
	D0	SPP0	(LSB)	1	0	0	R/W		
00FF02	D7	EBR	Bus release enable register (K11 and R51 terminal specification)	K11 $\overline{BREQ}$	Input port	0	R/W	*2	
	D6	WT2	Wait control register <u>WT2 WT1 WT0 Number of state</u> 1 1 1 14 1 1 0 12			0	R/W		
	D5	WT1	1 0 1 10 1 0 0 8 0 1 1 6 0 1 0 4						
	D4	WT0	0 0 1 2 0 0 0 No wait						
	D3	CLKCHG	CPU operating clock switch	OSC3	OSC1				0
	D2	OSCC	OSC3 oscillation On/Off control	On	Off	0	R/W		
	D1	VDC1	Operating mode selection <u>VDC1 VDC0 Operating mode</u> 1 × High speed ( $V_{D1}=3.3V$ )			0	R/W		
	D0	VDC0	0 1 Low power ( $V_{D1}=1.3V$ ) 0 0 Normal ( $V_{D1}=2.2V$ )						

\*1 This is just R/W register on E0C88348/317. \*2 This is just R/W register on E0C88308.

Note: All the interrupts including  $\overline{NMI}$  are disabled, until you write the optional value into both the "00FF00H" and "00FF01H" addresses.

I/O Map (MPU mode)

Address	Bit	Name	Function	1	0	SR	R/W	Comment																																				
00FF00 (MPU)	D7	BSMD1	Bus mode (CPU mode) <table border="1"> <thead> <tr> <th>BSMD1</th> <th>BSMD0</th> <th>Mode</th> </tr> </thead> <tbody> <tr> <td>1</td> <td>1</td> <td>512K (Maximum)</td> </tr> <tr> <td>1</td> <td>0</td> <td>512K (Minimum)</td> </tr> <tr> <td>0</td> <td>1</td> <td>64K</td> </tr> <tr> <td>0</td> <td>0</td> <td>* Option selection ←</td> </tr> </tbody> </table>	BSMD1	BSMD0	Mode	1	1	512K (Maximum)	1	0	512K (Minimum)	0	1	64K	0	0	* Option selection ←			*	R/W	* Initial setting can be selected among 3 types (64K, 512K min and 512K max) by mask option setting.																					
	BSMD1	BSMD0		Mode																																								
	1	1		512K (Maximum)																																								
	1	0		512K (Minimum)																																								
	0	1	64K																																									
	0	0	* Option selection ←																																									
	D6	BSMD0			*	R/W																																						
	D5	CEMD1	Chip enable mode <table border="1"> <thead> <tr> <th>CEMD1</th> <th>CEMD0</th> <th>Mode</th> </tr> </thead> <tbody> <tr> <td>1</td> <td>1</td> <td>64K (<math>\overline{CE0}</math>)</td> </tr> <tr> <td>1</td> <td>0</td> <td>32K (<math>\overline{CE0}</math>, <math>\overline{CE1}</math>)</td> </tr> <tr> <td>0</td> <td>1</td> <td>16K (<math>\overline{CE0}</math>–<math>\overline{CE3}</math>)</td> </tr> <tr> <td>0</td> <td>0</td> <td>8K (<math>\overline{CE0}</math>–<math>\overline{CE3}</math>)</td> </tr> </tbody> </table>	CEMD1	CEMD0	Mode	1	1	64K ( $\overline{CE0}$ )	1	0	32K ( $\overline{CE0}$ , $\overline{CE1}$ )	0	1	16K ( $\overline{CE0}$ – $\overline{CE3}$ )	0	0	8K ( $\overline{CE0}$ – $\overline{CE3}$ )			1	R/W	Only for 64K bus mode																					
	CEMD1	CEMD0		Mode																																								
	1	1	64K ( $\overline{CE0}$ )																																									
1	0	32K ( $\overline{CE0}$ , $\overline{CE1}$ )																																										
0	1	16K ( $\overline{CE0}$ – $\overline{CE3}$ )																																										
0	0	8K ( $\overline{CE0}$ – $\overline{CE3}$ )																																										
D4	CEMD0			1	R/W																																							
D3	CE3	$\overline{CE3}$ (R33)	$\overline{CE}$ signal output Enable/Disable Enable: $\overline{CE}$ signal output Disable: DC (R3x) output	$\overline{CE3}$ enable	$\overline{CE3}$ disable	0	R/W																																					
D2	CE2	$\overline{CE2}$ (R32)		$\overline{CE2}$ enable	$\overline{CE2}$ disable	0	R/W																																					
D1	CE1	$\overline{CE1}$ (R31)		$\overline{CE1}$ enable	$\overline{CE1}$ disable	0	R/W																																					
D0	CE0	$\overline{CE0}$ (R30)		$\overline{CE0}$ enable	$\overline{CE0}$ disable	1	R/W																																					
00FF01	D7	SPP7	Stack pointer page address (MSB)  < SP page allocatable address > • Single chip mode: only 0 page • 64K mode: only 0 page • 512K (min) mode: 0–27H page • 512K (max) mode: 0–27H page  (LSB)	1	0	0	R/W																																					
	D6	SPP6		1	0	0	R/W																																					
	D5	SPP5		1	0	0	R/W																																					
	D4	SPP4		1	0	0	R/W																																					
	D3	SPP3		1	0	0	R/W																																					
	D2	SPP2		1	0	0	R/W																																					
	D1	SPP1		1	0	0	R/W																																					
	D0	SPP0		1	0	0	R/W																																					
00FF02	D7	EBR	Bus release enable register (K11 and R51 terminal specification)	$\overline{BREQ}$ K11 BACK R51	Input port Output port	0	R/W	*1																																				
	D6	WT2	Wait control register <table border="1"> <thead> <tr> <th>WT2</th> <th>WT1</th> <th>WT0</th> <th>Number of state</th> </tr> </thead> <tbody> <tr> <td>1</td> <td>1</td> <td>1</td> <td>14</td> </tr> <tr> <td>1</td> <td>1</td> <td>0</td> <td>12</td> </tr> <tr> <td>1</td> <td>0</td> <td>1</td> <td>10</td> </tr> <tr> <td>1</td> <td>0</td> <td>0</td> <td>8</td> </tr> <tr> <td>0</td> <td>1</td> <td>1</td> <td>6</td> </tr> <tr> <td>0</td> <td>1</td> <td>0</td> <td>4</td> </tr> <tr> <td>0</td> <td>0</td> <td>1</td> <td>2</td> </tr> <tr> <td>0</td> <td>0</td> <td>0</td> <td>No wait</td> </tr> </tbody> </table>	WT2	WT1	WT0	Number of state	1	1	1	14	1	1	0	12	1	0	1	10	1	0	0	8	0	1	1	6	0	1	0	4	0	0	1	2	0	0	0	No wait			0	R/W	
	WT2	WT1		WT0	Number of state																																							
	1	1		1	14																																							
	1	1		0	12																																							
	1	0	1	10																																								
	1	0	0	8																																								
	0	1	1	6																																								
0	1	0	4																																									
0	0	1	2																																									
0	0	0	No wait																																									
D5	WT1				0	R/W																																						
D4	WT0																																											
D3	CLKCHG	CPU operating clock switch		OSC3	OSC1	0	R/W																																					
D2	OSCC	OSC3 oscillation On/Off control		On	Off	0	R/W																																					
D1	VDC1	Operating mode selection <table border="1"> <thead> <tr> <th>VDC1</th> <th>VDC0</th> <th>Operating mode</th> </tr> </thead> <tbody> <tr> <td>1</td> <td>×</td> <td>High speed (VD1=3.3V)</td> </tr> <tr> <td>0</td> <td>1</td> <td>Low power (VD1=1.3V)</td> </tr> <tr> <td>0</td> <td>0</td> <td>Normal (VD1=2.2V)</td> </tr> </tbody> </table>	VDC1	VDC0	Operating mode	1	×	High speed (VD1=3.3V)	0	1	Low power (VD1=1.3V)	0	0	Normal (VD1=2.2V)			0	R/W																										
VDC1	VDC0		Operating mode																																									
1	×	High speed (VD1=3.3V)																																										
0	1	Low power (VD1=1.3V)																																										
0	0	Normal (VD1=2.2V)																																										
D0	VDC0																																											

\*1 This is just R/W register on E0C88308.

Note: All the interrupts including  $\overline{NMI}$  are disabled, until you write the optional value into both the "00FF00H" and "00FF01H" addresses.



Specifications

**System controller settings and bus control**

- (1) *single\_chip*: E0C88316 Single chip mode
- (2) *mcu64k\_308*: E0C88308 MCU Expanded 64K mode
- (3) *mcu64k\_316*: E0C88316 MCU Expanded 64K mode
- (4) *mpu\_64k*: E0C88316 MPU Expanded 64K mode
- (5) *mpu512k\_max*: E0C88316 MPU Expanded 512K maximum mode

Each of the routines sets the system controller and bus as shown in the table below.

Table 2.1 Setting contents of each routine

Address	Setting item	(1)	(2)	(3)	(4)	(5)
0FF00H	CPU mode	Single chip	64K	64K	64K	512K
	Chip enable mode	No	$\overline{CE3}$ – $\overline{CE0}$ (16K)	$\overline{CE1}$ – $\overline{CE0}$ (32K)	$\overline{CE0}$ (64K)	$\overline{CE3}$ – $\overline{CE0}$ (128K)
	$\overline{CE}$ signal output	No	$\overline{CE3}$ – $\overline{CE0}$	$\overline{CE1}$ – $\overline{CE0}$	$\overline{CE0}$	$\overline{CE3}$ – $\overline{CE0}$
0FF01H	Stack page	Page 0	←	←	←	Page 27H
0FF02H	Bus release (Note)	No	←	←	←	Use
	Wait control	No	2	4	8	0
	CPU operating clock	OSC1	←	←	←	←
	OSC3 oscillation circuit	Off	←	←	←	←
	Operating mode	Normal mode	←	←	←	←

Flowchart

**System controller settings and bus control (1), (2), (3), (4), (5)**

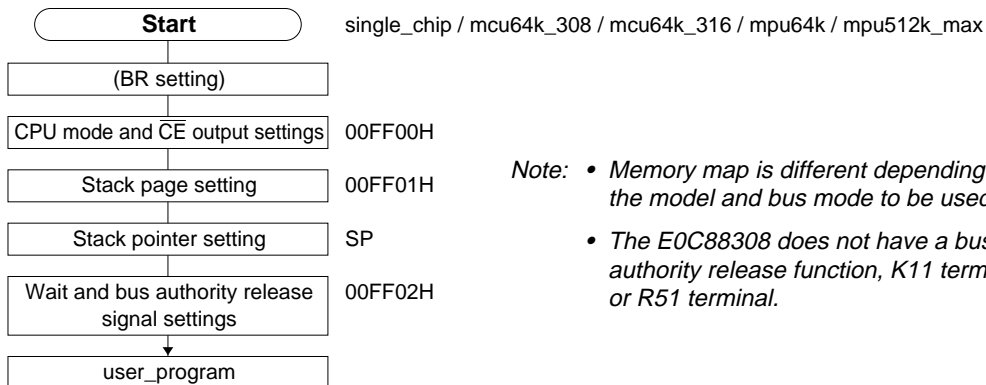

- Note:
- Memory map is different depending on the model and bus mode to be used.
  - The E0C88308 does not have a bus authority release function, K11 terminal or R51 terminal.

**Notes**

- (1) Prior to any other processing, be sure to set the system controller and bus control in an initialization routine executed immediately after an initial reset.
- (2) When using the MPU mode, the output of  $\overline{CE0}$  signal is set to valid at initial reset. Be sure not to set the  $\overline{CE0}$  output to invalid when setting the system controller.
- (3) The  $\overline{CE0}$ – $\overline{CE3}$  output terminals are shared with the R30–R33 terminals. Consequently, the terminals which have been set for  $\overline{CE}$  outputs cannot be used as a general purpose output port, including the high impedance control. Moreover, since the output terminals shift to LOW if "0" is written to the R30–R33 registers prior setting the  $\overline{CE}$  outputs, be sure to avoid this.
- (4) When using the bus release function, the K11 and R51 terminals function as the  $\overline{BREQ}$  and  $\overline{BACK}$  terminals, respectively. Consequently, K11 and R51 cannot be used as an input port and a output port.

**Source List****System controller settings and bus control**

```

external      user_program
public        single_chip,mcu64k_308,mcu64k_316,mpu_64k,mpu512k_max
;
br_io         equ      0ffh                ;base reg. address (set i/o area)
mcu           equ      00ff00h            ;mcu mode system control address
mpu           equ      00ff00h            ;mpu mode system control address
spp           equ      00ff01h            ;stack pointer page address
mode         equ      00ff02h            ;mcu/mpu mode control address
;
sp_308       equ      00f100h            ;e0c88308 stack pointer
sp_316       equ      00f800h            ;e0c88316 stack pointer
;
code

```

**(1) E0C88316 Single chip mode**

```

;*****
;*
;*      single chip mode with e0c88316
;*
;*****
single_chip:
    ld      br,#br_io                ;set br reg. address to 0ffxxh
    ld      [br:low mcu],#00110000b   ;single chip mode /ce3-/ce0 disable
    ld      [br:low spp],#00h         ;set stack pointer page to 0
    ld      sp,#lod sp_316           ;stack pointer set
    ld      [br:low mode],#00000000b  ;set mode reg. to initial value
    jrl    user_program              ;jump user program

```

(1)

**(2) E0C88308 MCU Expanded 64K mode**

```

;*****
;*
;*      mcu 64k mode with e0c88308
;*
;*****
mcu64k_308:
    ld      br,#br_io                ;set br reg. address to 0ffxxh
    ld      [br:low mcu],#01011111b   ;mcu 64k mode /ce3 to /ce0(16kb) enable
    ld      [br:low spp],#00h         ;set stack pointer page to 0
    ld      sp,#lod sp_308           ;stack pointer set
    ld      [br:low mode],#00010000b  ;set mode reg. to 2 wait states
    jrl    user_program              ;jump user program

```

(2)

Source List

**(3) E0C88316 MCU Expanded 64K mode**

```

;*****
;*
;*          mcu 64k mode with e0c88316          *
;*          *                                  *
;*****
mcu64k_316:
    ld    br,#br_io                ;set br reg. address to 0ffxxh
    ld    [br:low mcu],#01100011b   ;mcu 64k mode /ce1-/ce0(32kb) enable
    ld    [br:low spp],#00h        ;set stack pointer page to 0
    ld    sp,#lod sp_316          ;stack pointer set
    ld    [br:low mode],#00100000b ;set mode reg. to 4 wait states
    jrl   user_program            ;jump user program
    
```

**(4) E0C88316 MPU Expanded 64K mode**

```

;*****
;*
;*          mpu 64k mode with e0c88316          *
;*          *                                  *
;*****
mpu_64k:
    ld    br,#br_io                ;set br reg. address to 0ffxxh
    ld    [br:low mcu],#01110001b   ;mpu 64k mode /ce0(64kb) enable
    ld    [br:low spp],#00h        ;set stack pointer page to 0
    ld    sp,#lod sp_316          ;stack pointer set
    ld    [br:low mode],#01000000b ;set mode reg. to 8 wait states
    jrl   user_program            ;jump user program
    
```

**(5) E0C88316 MPU Expanded 512K maximum mode**

```

;*****
;*
;*          mpu 512k maximum mode with e0c88316 *
;*          *                                  *
;*****
mpu512k_max:
    ld    br,#br_io                ;set br reg. address to 0ffxxh
    ld    [br:low mcu],#11111111b   ;mpu 512k mode /ce3-/ce0(128kb) enable
    ld    [br:low spp],#27h        ;set stack pointer page 27h
    ld    sp,#lod sp_316          ;stack pointer set
    ld    [br:low mode],#10000000b ;set mode reg. to 0 wait states
;
    jrl   user_program            ;and breq,/back enable
    end                            ;jump user program
    
```

# 3 WATCHDOG TIMER

## I/O Map

Address	Bit	Name	Function	1	0	SR	R/W	Comment																																				
00FF40	D7	–	–	–	–	–		"0" when being read																																				
	D6	FOUT2	FOUT frequency selection <table border="1"> <thead> <tr> <th>FOUT2</th> <th>FOUT1</th> <th>FOUT0</th> <th>Frequency</th> </tr> </thead> <tbody> <tr> <td>0</td> <td>0</td> <td>0</td> <td>fosc1 / 1</td> </tr> <tr> <td>0</td> <td>0</td> <td>1</td> <td>fosc1 / 2</td> </tr> <tr> <td>0</td> <td>1</td> <td>0</td> <td>fosc1 / 4</td> </tr> <tr> <td>0</td> <td>1</td> <td>1</td> <td>fosc1 / 8</td> </tr> <tr> <td>1</td> <td>0</td> <td>0</td> <td>fosc3 / 1</td> </tr> <tr> <td>1</td> <td>0</td> <td>1</td> <td>fosc3 / 2</td> </tr> <tr> <td>1</td> <td>1</td> <td>0</td> <td>fosc3 / 4</td> </tr> <tr> <td>1</td> <td>1</td> <td>1</td> <td>fosc3 / 8</td> </tr> </tbody> </table>	FOUT2	FOUT1	FOUT0	Frequency	0	0	0	fosc1 / 1	0	0	1	fosc1 / 2	0	1	0	fosc1 / 4	0	1	1	fosc1 / 8	1	0	0	fosc3 / 1	1	0	1	fosc3 / 2	1	1	0	fosc3 / 4	1	1	1	fosc3 / 8			0	R/W	
	FOUT2	FOUT1		FOUT0	Frequency																																							
	0	0		0	fosc1 / 1																																							
	0	0		1	fosc1 / 2																																							
	0	1	0	fosc1 / 4																																								
	0	1	1	fosc1 / 8																																								
	1	0	0	fosc3 / 1																																								
	1	0	1	fosc3 / 2																																								
	1	1	0	fosc3 / 4																																								
1	1	1	fosc3 / 8																																									
D5	FOUT1					0	R/W																																					
D4	FOUT0					0	R/W																																					
D3	FOUTON	FOUT output control		On	Off	0	R/W																																					
D2	WDRST	Watchdog timer reset		Reset	No operation	–	W	Constantly "0" when being read																																				
D1	TMRST	Clock timer reset		Reset	No operation	–	W																																					
D0	TMRUN	Clock timer Run/Stop control		Run	Stop	0	R/W																																					

## Specifications

### Watchdog timer processing

*Vector address setting for watchdog timer ( $\overline{\text{NMI}}$ ) interrupt*

(1) *watchdog\_reset: Watchdog timer reset*

(2) *nmi\_intr: Watchdog timer ( $\overline{\text{NMI}}$ ) interrupt processing*

## Flowchart

### (1) Watchdog timer reset

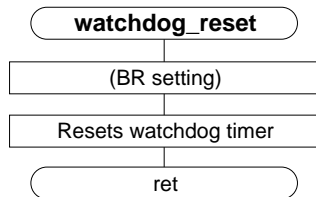

### (2) Watchdog timer ( $\overline{\text{NMI}}$ ) interrupt processing

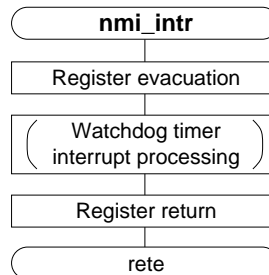

## Notes

- (1) Since the watchdog timer ( $\overline{\text{NMI}}$ ) interrupt cannot be masked, be sure to declare the watchdog timer ( $\overline{\text{NMI}}$ ) interrupt processing routine and the vector address, regardless of whether or not the watchdog timer is used.
- (2) In this program example for the watchdog timer, the vector address setting and program have been allocated from 003000H for the sake of convenience.
- (3) Do not execute the SLP instruction for 2 msec after a  $\overline{\text{NMI}}$  interrupt has occurred (when fosc1 is 32.768 kHz).

### 3 WATCHDOG TIMER

#### Source List

##### **Watchdog timer processing**

```
public watchdog_reset,nmi_intr
;
nmi_vector equ 000004h ;watchdog /nmi interrupt routine
watchdog equ 003000h ;program start address offset
br_io equ 0ffh ;base reg. address (set i/o area)
rtm_mode equ 00ff40h ;timer mode set address
;
;
code
```

##### **Vector address setting for watchdog timer ( $\overline{\text{NMI}}$ ) interrupt**

```
intr_vectors:
;
org intr_vectors+nmi_vector
dw nmi_intr
;
```

##### **(1) Watchdog timer reset**

```
org intr_vectors+watchdog
;*****
;*
;* watchdog timer reset
;*
;*****
watchdog_reset:
ld br,#br_io ;set br reg. address to 0ffxxh
or [br:low rtm_mode],#00000100b ;watchdogtimer reset
ret
;
```

(1)

##### **(2) Watchdog timer ( $\overline{\text{NMI}}$ ) interrupt processing**

```
;*****
;*
;* /nmi (watchdog) interrupt routine
;*
;*****
nmi_intr:
push ale
;
;
; /nmi (watchdog) interrupt routine
;
;
pop ale
rete
end
```

(2)

# 4 OSCILLATION CIRCUIT

## I/O Map

Address	Bit	Name	Function	1	0	SR	R/W	Comment	
00FF02	D7	EBR	Bus release enable register	K11	BREQ	Input port	0	R/W	*1
			(K11 and R51 terminal specification)	R51	BACK				
	D6	WT2	Wait control register		Number of state				
			WT2	WT1					
	D5	WT1	1	1	1	14	0	R/W	
			1	1	0	12			
			1	0	1	10			
			1	0	0	8			
	D4	WT0	0	1	1	6			
			0	1	0	4			
0			0	1	2				
			0	0	0	No wait			
D3	CLKCHG	CPU operating clock switch		OSC3	OSC1	0	R/W		
D2	OSCC	OSC3 oscillation On/Off control		On	Off	0	R/W		
D1	VDC1	Operating mode selection					0	R/W	
		VDC1	VDC0	Operating mode					
		1	×	High speed (VD1=3.3V)					
D0	VDC0	0	1	Low power (VD1=1.3V)					
		0	0	Normal (VD1=2.2V)					

\*1 This is just R/W register on E0C88308.

## Specifications

### CPU clock switching

#### (1) *osc1toosc3: Switching from OSC1 to OSC3*

Checks supply voltage and switches system clock from OSC1 (low power mode, VD1 = 1.3 V) to OSC3 (normal mode, VD1 = 2.2 V).

#### (2) *osc3toosc1: Switching from OSC3 to OSC1*

Switches system clock from OSC3 (normal mode, VD1 = 2.2 V) to OSC1 (low power mode, VD1 = 1.3 V).

## Notes

- (1) Delay routines for the OSC3 oscillation stabilization waiting time, VD1 voltage stabilization waiting time (wait time until OSC3 turns on after operating mode switching, 5 msec or more), etc. are not included in this program example, so it is necessary to create them separately using a hardware timer or software timer. (external call: osc3\_delay, vd1\_delay)
- (2) Switching operating modes when the supply voltage is lower than the VD1 setting may cause a malfunction. Hence, perform operating mode switching only after making sure that the power voltage of SVD is more than the VD1 setting voltage (absolute value). (external call: svd\_auto)  
The program example sets the NG flag (vdd\_ngf) and terminates processing without switching the system clock, when the supply voltage is lower than the VD1 setting.
- (3) When switching from OSC3 to OSC1 (VD1 = 2.2 V → 1.3 V), the program example does not perform special checking of the supply voltage of SVD if the supply voltage is already more than the VD1 setting.
- (4) Pay special attention the delay routine setting since the OSC3 oscillation stabilization waiting time varies somewhat depending on the oscillator and externally attached parts used.
- (5) Because of operating voltage considerations, both modes (low power mode and high speed mode) cannot be used in one application.

*Flowchart*

**(1) Switching from OSC1 to OSC3**

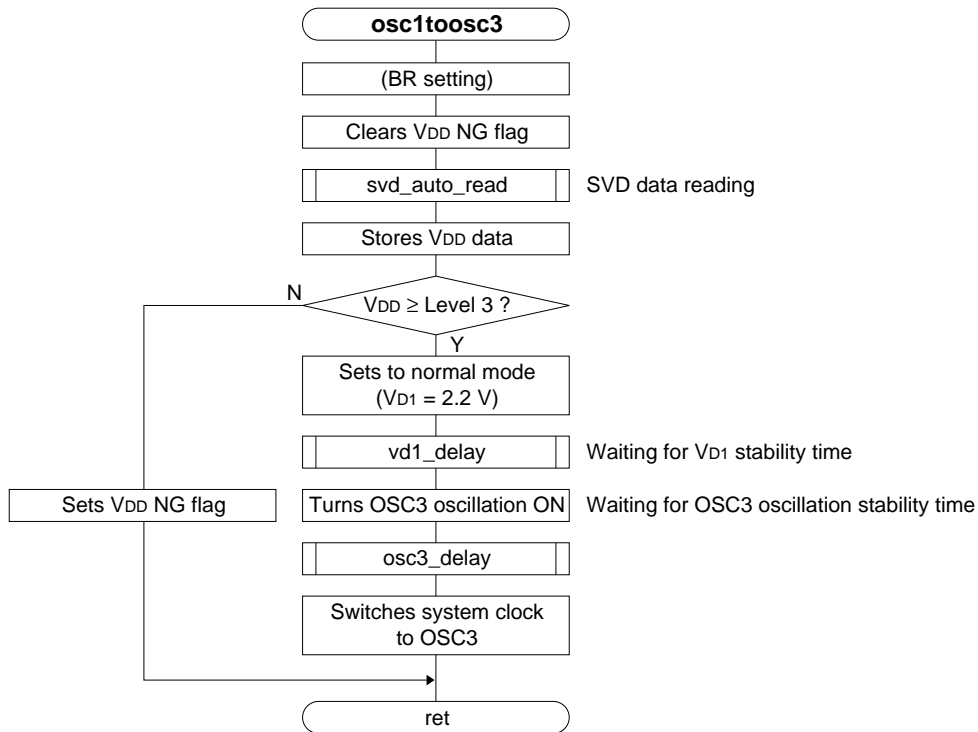

**(2) Switching from OSC3 to OSC1**

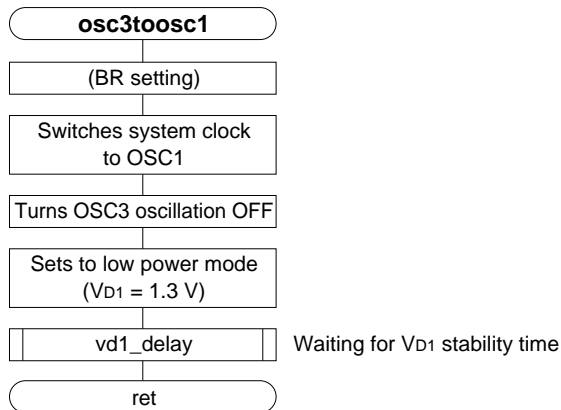

## Source List

**CPU clock switching**

```

        external    osc3_delay,vd1_delay
        external    svd_auto_read
        public      osc1toosc3,osc3toosc1
        public      vdd_ngf,vdd_data
;
br_io      equ      0ffh                ;base reg. address (set i/o area)
mode       equ      00ff02h           ;mcu//mpu mode control address
;
        data
vdd_ngf:   db      [1]                ;vdd ng flag
vdd_data:  db      [1]                ;vdd detection data
        code

```

**(1) Switching from OSC1 to OSC3**

```

;*****
;*
;* change osc1(low power mode [vd1=1.3v]) to osc3(normal mode [vd1=2.2v]) *
;*
;*****
osc1toosc3:
    ld    br,#br_io                ;set br reg. address to 0ffxxh
    xor   a,a
    ld    [lod vdd_ngf],a          ;vdd ng flag clear
    ld    [lod vdd_data],a        ;vdd data store
    carl  svd_auto_read            ;svd check ***
    ld    [lod vdd_data],a        ;vdd store
    cp    a,#03h                  ;areg=svd data
    jrs   c,osc1toosc300          ;vdd >= level 3
;
    and   [br:low mode],#11111100b ;change mode to normal (vd1 to 2.2v)
    or    [br:low mode],#00000100b ;osc3 clock on
    carl  osc3_delay              ;osc3 start up delay ***
    or    [br:low mode],#00001000b ;change system clock to osc3
    jrs   osc1toosc301
;
osc1toosc300:
    ld    a,#0ffh
    ld    [lod vdd_ngf],a        ;vdd ng flag set
osc1toosc301:
    ret
;

```

(1)

**(2) Switching from OSC3 to OSC1**

```

;*****
;*
;* change osc3(normal mode [vd1=2.2v]) to osc1(low power mode [vd1=1.3v]) *
;*
;*****
osc3toosc1:
    ld    br,#br_io                ;set br reg. address to 0ffxxh
    and   [br:low mode],#11110111b ;change system clock to osc1
    and   [br:low mode],#11111011b ;osc3 clock off
    or    [br:low mode],#00000001b ;change mode to low power (vd1 to 1.3v)
    carl  vd1_delay              ;vd1 delay ***
    ret
;
    end

```

(2)



# 5 INPUT PORTS (K PORTS)

## I/O Map

Address	Bit	Name	Function	1	0	SR	R/W	Comment
00FF50	D7	SIK07	K07 interrupt selection register	Interrupt enable	Interrupt disable	0	R/W	
	D6	SIK06	K06 interrupt selection register					
	D5	SIK05	K05 interrupt selection register					
	D4	SIK04	K04 interrupt selection register					
	D3	SIK03	K03 interrupt selection register					
	D2	SIK02	K02 interrupt selection register					
	D1	SIK01	K01 interrupt selection register					
	D0	SIK00	K00 interrupt selection register					
00FF51	D7	–	–	–	–	–	–	Constantly "0" when being read
	D6	–	–	–	–	–	–	
	D5	–	–	–	–	–	–	
	D4	–	–	–	–	–	–	
	D3	–	–	–	–	–	–	
	D2	–	–	–	–	–	–	
	D1	SIK11	K11 interrupt selection register	Interrupt enable	Interrupt disable	0	R/W	*1
	D0	SIK10	K10 interrupt selection register					
00FF52	D7	KCP07	K07 interrupt comparison register	Interrupt generated at falling edge	Interrupt generated at rising edge	1	R/W	
	D6	KCP06	K06 interrupt comparison register					
	D5	KCP05	K05 interrupt comparison register					
	D4	KCP04	K04 interrupt comparison register					
	D3	KCP03	K03 interrupt comparison register					
	D2	KCP02	K02 interrupt comparison register					
	D1	KCP01	K01 interrupt comparison register					
	D0	KCP00	K00 interrupt comparison register					
00FF53	D7	–	–	–	–	–	–	Constantly "0" when being read
	D6	–	–	–	–	–	–	
	D5	–	–	–	–	–	–	
	D4	–	–	–	–	–	–	
	D3	–	–	–	–	–	–	
	D2	–	–	–	–	–	–	
	D1	KCP11	K11 interrupt comparison register	Falling edge	Rising edge	1	R/W	*2
	D0	KCP10	K10 interrupt comparison register					
00FF54	D7	K07D	K07 input port data	High level input	Low level input	–	R	
	D6	K06D	K06 input port data					
	D5	K05D	K05 input port data					
	D4	K04D	K04 input port data					
	D3	K03D	K03 input port data					
	D2	K02D	K02 input port data					
	D1	K01D	K01 input port data					
	D0	K00D	K00 input port data					
00FF55	D7	–	–	–	–	–	–	Constantly "0" when being read
	D6	–	–	–	–	–	–	
	D5	–	–	–	–	–	–	
	D4	–	–	–	–	–	–	
	D3	–	–	–	–	–	–	
	D2	–	–	–	–	–	–	
	D1	K11D	K11 input port data	High level input	Low level input	–	R	*3
	D0	K10D	K10 input port data					

\*1 Set constantly "0" on E0C88308.

\*3 Constantly "1" when being read on E0C88308.

\*2 Set constantly "1" on E0C88308.

*I/O Map*

Address	Bit	Name	Function	1	0	SR	R/W	Comment	
00FF20	D7	PK01	K00–K07 interrupt priority register	PK01	PK00	0	R/W		
	D6	PK00							
	D5	PSIF1	Serial interface interrupt priority register	PSIF1	PSIF0	0	R/W		
	D4	PSIF0							
	D3	PSW1	Stopwatch timer interrupt priority register	1	1	Level 3	0		R/W
	D2	PSW0							
	D1	PTM1	Clock timer interrupt priority register	1	0	Level 2	0		R/W
D0	PTM0								
00FF21	D7	–	–	–	–	–	–	Constantly "0" when being read	
	D6	–	–	–	–	–	–		
	D5	–	–	–	–	–	–		
	D4	–	–	–	–	–	–	–	
	D3	PPT1	Programmable timer interrupt priority register	PPT1	PPT0	Priority level	0	R/W	
	D2	PPT0							
D1	PK11	K10 and K11 interrupt priority register	1	0	Level 2	0	R/W		
D0	PK10								
00FF23	D7	EPT1	Programmable timer 1 interrupt enable register	Interrupt enable	Interrupt disable	0	R/W		
	D6	EPT0	Programmable timer 0 interrupt enable register						
	D5	EK1	K10 and K11 interrupt enable register						
	D4	EK0H	K04–K07 interrupt enable register						
	D3	EK0L	K00–K03 interrupt enable register						
	D2	ESERR	Serial I/F (error) interrupt enable register						
	D1	ESREC	Serial I/F (receiving) interrupt enable register						
D0	ESTRA	Serial I/F (transmitting) interrupt enable register							
00FF25	D7	FPT1	Programmable timer 1 interrupt factor flag	(R)	(R)	0	R/W		
	D6	FPT0	Programmable timer 0 interrupt factor flag	Interrupt factor is generated	No interrupt factor is generated				
	D5	FK1	K10 and K11 interrupt factor flag						
	D4	FK0H	K04–K07 interrupt factor flag						
	D3	FK0L	K00–K03 interrupt factor flag	(W) Reset	(W) No operation				
	D2	FSERR	Serial I/F (error) interrupt factor flag						
	D1	FSREC	Serial I/F (receiving) interrupt factor flag						
D0	FSTRA	Serial I/F (transmitting) interrupt factor flag							

Specifications

**Control of input port (K port )**

**Vector address setting for input port (K port) interrupt**

**(1) input\_normal: Data reading from normal input port (K port)**

**(2) input\_keyscan: Key scan for 8 x 2 key matrix**

Assumes the key matrix has been configured with input and output as shown in Figure 5.1, and specifies the key pressed and then stores the data into the RAM area named key\_data.

**<Conditions>**

K07–K00 ports: Input with pull-up resistor (mask option setting)

R01, R00 ports: Nch open drain output (mask option setting)

key\_data: 1 word

	7	6	5	4	3	2	1	0	
key_data +0	K07	K06	K05	K04	K03	K02	K01	K00	(R00)
+1	K07	K06	K05	K04	K03	K02	K01	K00	(R01)

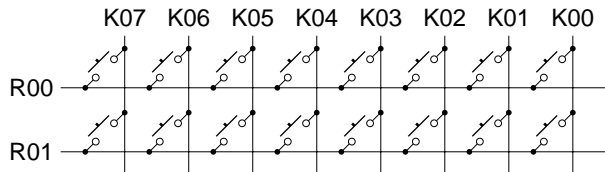

Fig. 5.1 Key matrix

**(3) input\_keywait, input\_keyintr: Interrupt condition setting and interrupt processing for input port (K port)**

Generates an IRQ3 interrupt when changing the input port K10 and K11 from HIGH to LOW.

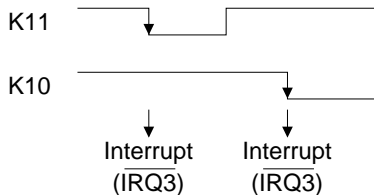
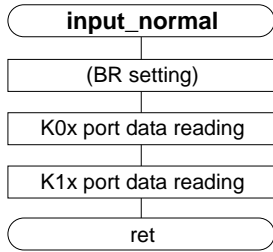

Fig. 5.2 Interrupt generation timing

Flowchart

(1) Data reading from normal input port (K port)



(2) Key scanning on 8 x 2 key matrix

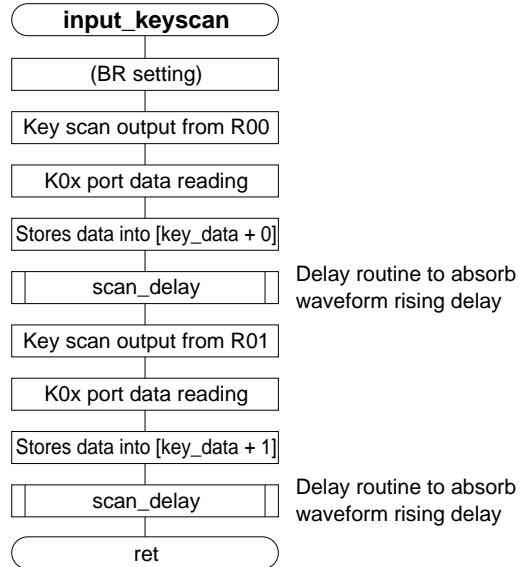

(3) Interrupt condition setting and interrupt processing for input port (K port)

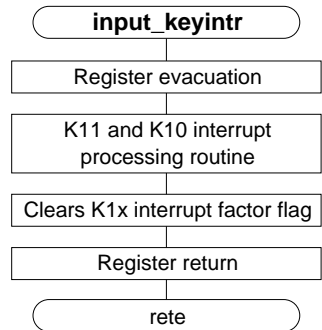
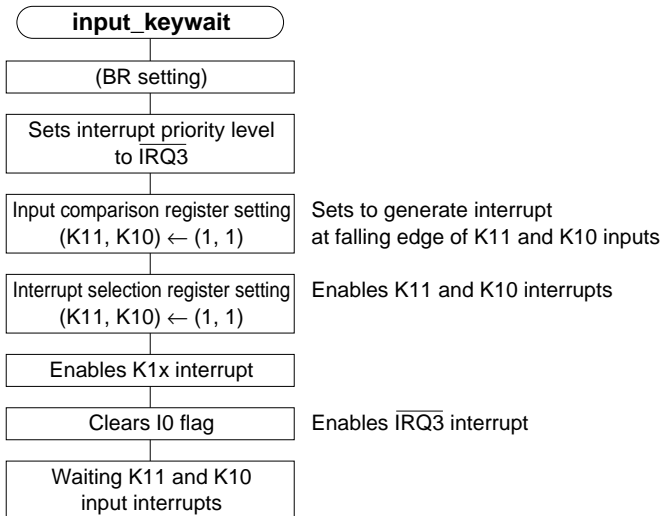

Note: The E0C88308 does not have K11 terminal.

## 5 INPUT PORTS (K PORTS)

### Notes

- (1) When the pull-up resistor option has been set to "with resistor", a delay in the waveform rise time will occur depending on the time constant of the input gate capacitance when changing the input terminal from LOW to HIGH. For this reason, set an appropriate wait time (for reference, approximately 500  $\mu$ sec) for the introduction of the input port. In particular, special attention should be paid to key scanning for key matrix formation.
- (2) Note that the K11 terminal cannot be used as an input port when the K11 terminal has been set for input of the bus release request (BREQ) signal.  
See Part I in this manual, "E0C88348/317/316/308 Technical Hardware", for details of the bus release sequence.
- (3) The K10 terminal doubles as the input terminal of the programmable timer/event counter with input port functions sharing the input signal as it is. For this reason, when the K10 terminal has been set to the input terminal of the programmable timer/event counter, pay attention to interrupt setting.  
See "12 PROGRAMMABLE TIMER", for the control of the programmable timer/event counter.
- (4) To reset the interrupt factor flag, write "1" into the corresponding flags alone, using the AND or LD instruction. When the OR logic operation instruction has been used, "1" is written for the interrupt factor flags that have been set to "1" within the same address and those flags are then clear.
- (5) The interrupt flags (I1 and I0) have not been reset in the interrupt processing routine of this program example, so an interrupt lower than  $\overline{\text{IRQ3}}$  level is disabled at the time of generation. When you wish to accept the next interrupt after an interrupt has been generated, re-setting of the interrupt flags or resetting the interrupt factor flag is necessary after due consideration for the nesting level.
- (6) A noise reject circuit is not included in the input port (K port).  
In particular, when input port data is read using an interrupt, the interrupt may generate one of the another by key chattering. For this reason, some measure must be devised such as adding noise reject processing in software or with an external.
- (7) In this program example for input port (K port), the vector address setting and program have been allocated from 003000H for the sake of convenience.
- (8) The E0C88308 does not have K11 terminal.

### Source List

#### Control of input port (K port)

```
external scan_delay
public input_normal, input_keyscan, input_keywait, input_keyintr
public key_data
;
klx_vector equ 00000ah ;klx interrupt vector address offset
keyinput equ 003000h ;program start address offset
br_io equ 0ffh ;base reg. address (set i/o area)
sik1 equ 00ff51h ;interrupt selection reg. for klx
kcp1 equ 00ff53h ;interrupt comparison reg. for klx
k0d equ 00ff54h ;input port data from k0x
k1d equ 00ff55h ;input port data from klx
r0d equ 00ff73h ;r0x output data
intr_pr1 equ 00ff21h ;interrupt priority reg. 0
intr_en1 equ 00ff23h ;interrupt enable reg. 0
intr_fac1 equ 00ff25h ;interrupt factor flag reg. 0
;
data
key_data: dw [1]
code
```

## Source List

**Vector address setting for input port (K port) interrupt**

```

intr_vectors:
;
        org     intr_vectors+k1x_vector
        dw     input_keyintr           ;k1x interrupt processing routine

```

**(1) Data reading from normal input port (K port)**

```

        org     intr_vectors+keyinput
;*****
;*
;*     k(input) port read (normal)
;*     a <- k0x(complementary)
;*     b <- k1x(complementary)
;*
;*****
input_normal:
        ld     br,#br_io               ;set br reg. address to 0ffxxh
        ld     a,[br:low k0d]          ;k07-00 port read
        ld     b,[br:low k1d]          ;k11-00 port read
        ret
;

```

(1)

**(2) Key scanning on 8 x 2 key matrix**

```

;*****
;*
;*     k(input) port read (key scan)
;*     k07 k06 k05 k04 k03 k02 k01 k00(pull up)
;*     r00(n-ch. o.d)
;*     r01(n-ch. o.d)
;*
;*     key_data+0(r10) <- k07 k06 k05 k04 k03 k02 k01 k00
;*     key_data+1(r11) <- r07 k06 k05 k04 k03 k02 k01 k00
;*
;*****
input_keyscan:
        ld     br,#br_io               ;set br reg. address to 0ffxxh
        and    [br:low r0d],#11111110b ;r00 key scan output
        ld     a,[br:low k0d]          ;k0x port read
        ld     [lod key_data+0],a      ;key_data save
        carl   scan_delay              ;key scan delay ***
        and    [br:low r0d],#11111101b ;r01 key scan output
        ld     a,[br:low k0d]          ;k0x port read
        ld     [lod key_data+1],a      ;key_data save
        carl   scan_delay              ;key scan delay ***
        ret
;

```

(2)

**(3) Interrupt condition setting and interrupt processing for input port (K port)**

```

;*****
;*
;*     k(input) port read (interrupt)
;*     k11,10 <- /irq3 falling edge ("h" - "l") interrupt
;*
;*****
input_keywait:
        ld     br,#br_io               ;set br reg. address to 0ffxxh
        or     [br:low intr_pr1],#00000011b ;set pk11 and 10 to /irq3
        ld     [br:low kcp1],#00000011b ;k11,10 falling edge (h -> l)
        ld     [br:low sik1],#00000011b ;k11,10 interrupt enable
        or     [br:low intr_en1],#00100000b ;ek1 (k11,10) interrupt en.
;

```

(3)

## 5 INPUT PORTS (K PORTS)

### Source List

```
        ld    [br:low r0d],#00000000b    ;waiting key on r0d scan low output
        ld    a,sc
        and   a,#00111111b
        or    a,#10000000b
        ld    sc,a                        ;i0 flag clear (en. /irq3 intr.)
;waiting k11,10 interrupt
;
;*****
;*
;*      k1x interrupt processing routine
;*
;*****
input_keyintr:
        push  ale
;
;      k11 and 10 interrupt processing routine
;
        and   [br:low intr_fac1],#00100000b ;clear fk1 (k11,10) flag
        pop   ale
        rete
;
        end
```

(3)

# 6 OUTPUT PORTS (R PORTS)

## I/O Map

Address	Bit	Name	Function	1	0	SR	R/W	Comment
00FF70	D7	HZR51	R51 high impedance control	High impedance	Complementary	0	R/W	*1
	D6	HZR50	R50 high impedance control					
	D5	HZR4H	R/W register	1	0	0	R/W	Reserved register
	D4	HZR4L	R/W register					
	D3	HZR1H	R14–R17 high impedance control	High impedance	Complementary	0	R/W	
	D2	HZR1L	R10–R13 high impedance control					
	D1	HZR0H	R04–R07 high impedance control					
	D0	HZR0L	R00–R03 high impedance control					
00FF71	D7	HZR27	R27 high impedance control	High impedance	Complementary	0	R/W	
	D6	HZR26	R26 high impedance control					
	D5	HZR25	R25 high impedance control					
	D4	HZR24	R24 high impedance control					
	D3	HZR23	R23 high impedance control					
	D2	HZR22	R22 high impedance control					
	D1	HZR21	R21 high impedance control					
	D0	HZR20	R20 high impedance control					
00FF72	D7	HZR37	R37 high impedance control	High impedance	Complementary	0	R/W	These are just R/W registers on E0C88308
	D6	HZR36	R36 high impedance control					
	D5	HZR35	R35 high impedance control					
	D4	HZR34	R34 high impedance control					
	D3	HZR33	R33 high impedance control					
	D2	HZR32	R32 high impedance control					
	D1	HZR31	R31 high impedance control					
	D0	HZR30	R30 high impedance control					
00FF73	D7	R07D	R07 output port data	High	Low	1	R/W	
	D6	R06D	R06 output port data					
	D5	R05D	R05 output port data					
	D4	R04D	R04 output port data					
	D3	R03D	R03 output port data					
	D2	R02D	R02 output port data					
	D1	R01D	R01 output port data					
	D0	R00D	R00 output port data					
00FF74	D7	R17D	R17 output port data	High	Low	1	R/W	
	D6	R16D	R16 output port data					
	D5	R15D	R15 output port data					
	D4	R14D	R14 output port data					
	D3	R13D	R13 output port data					
	D2	R12D	R12 output port data					
	D1	R11D	R11 output port data					
	D0	R10D	R10 output port data					
00FF75	D7	R27D	R27 output port data	High	Low	1	R/W	
	D6	R26D	R26 output port data					
	D5	R25D	R25 output port data					
	D4	R24D	R24 output port data					
	D3	R23D	R23 output port data					
	D2	R22D	R22 output port data					
	D1	R21D	R21 output port data					
	D0	R20D	R20 output port data					

\*1 This is just R/W register on E0C88308.



## 6 OUTPUT PORTS (R PORTS)

### I/O Map

Address	Bit	Name	Function	1	0	SR	R/W	Comment	
00FF76	D7	R37D	R37 output port data	High	Low	1	R/W	These are just R/W registers on E0C88308	
	D6	R36D	R36 output port data						
	D5	R35D	R35 output port data						
	D4	R34D	R34 output port data						
	D3	R33D	R33 output port data						
	D2	R32D	R32 output port data						
	D1	R31D	R31 output port data						
	D0	R30D	R30 output port data						
00FF77	D7	R47D	R/W register	1	0	1	R/W	Reserved register	
	D6	R46D	R/W register						
	D5	R45D	R/W register						
	D4	R44D	R/W register						
	D3	R43D	R/W register						
	D2	R42D	R/W register						
	D1	R41D	R/W register						
	D0	R40D	R/W register						
00FF78	D7	–	–	–	–	–	–	Constantly "0" when being read	
	D6	–	–	–	–	–	–		
	D5	–	–	–	–	–	–		
	D4	–	–	–	–	–	–		
	D3	–	–	–	–	–	–		
	D2	–	–	–	–	–	–		
	D1	R51D	R51 output port data	High	Low	1	R/W		*1
	D0	R50D	R50 output port data	High	Low	0	R/W		
00FF10	D7	–	–	–	–	–	–	Constantly "0" when being read	
	D6	–	–	–	–	–	–		
	D5	–	–	–	–	–	–		
	D4	LCCLK	CL output control for expanded LCD driver	On	Off	0	R/W		
	D3	LCFRM	FR output control for expanded LCD driver	On	Off	0	R/W		
	D2	DTFNT	LCD dot font selection	5 x 5 dots	5 x 8 dots	0	R/W		
	D1	LDUTY	LCD drive duty selection	1/16 duty	1/32 duty	0	R/W		*2
	D0	SGOUT	R/W register	1	0	0	R/W		Reserved register
00FF30	D7	–	–	–	–	–	–	Constantly "0" when being read	
	D6	–	–	–	–	–	–		
	D5	–	–	–	–	–	–		
	D4	MODE16	8/16-bit mode selection	16-bit x 1	8-bit x 2	0	R/W		
	D3	CHSEL	TOUT output channel selection	Timer 1	Timer 0	0	R/W		
	D2	PTOUT	TOUT output control	On	Off	0	R/W		
	D1	CKSEL1	Prescaler 1 source clock selection	fosc3	fosc1	0	R/W		
	D0	CKSEL0	Prescaler 0 source clock selection	fosc3	fosc1	0	R/W		
00FF44	D7	–	–	–	–	–	–	Constantly "0" when being read	
	D6	BZSTP	One-shot buzzer forcibly stop	Forcibly stop	No operation	–	W		
	D5	BZSHT	One-shot buzzer trigger/status	R	Busy	Ready	0		R/W
				W	Trigger	No operation			
	D4	SHTPW	One-shot buzzer duration width selection	125 msec	31.25 msec	0	R/W		
	D3	ENRTM	Envelope attenuation time	1 sec	0.5 sec	0	R/W		
	D2	ENRST	Envelope reset	Reset	No operation	–	W		"0" when being read
	D1	ENON	Envelope On/Off control	On	Off	0	R/W		*3
D0	BZON	Buzzer output control	On	Off	0	R/W			

\*1 This is just R/W register on E0C88308.

\*2 When 1/8 duty has been selected by mask option, setting of this register becomes invalid.

\*3 Reset to "0" during one-shot output.

**I/O Map**

Address	Bit	Name	Function	1	0	SR	R/W	Comment	
00FF40	D7	–	–	–	–	–		"0" when being read	
	D6	FOUT2	FOUT frequency selection					0	R/W
			FOUT2	FOUT1	FOUT0	Frequency			
			0	0	0	fosc1 / 1			
			0	0	1	fosc1 / 2			
	D5	FOUT1	0	1	0	fosc1 / 4	0	R/W	
			0	1	1	fosc1 / 8			
	D4	FOUT0	1	0	0	fosc3 / 1	0	R/W	
			1	0	1	fosc3 / 2			
			1	1	0	fosc3 / 4			
		1	1	1	fosc3 / 8				
D3	FOUTON	FOUT output control		On	Off	0	R/W		
D2	WDRST	Watchdog timer reset		Reset	No operation	–	W	Constantly "0" when	
D1	TMRST	Clock timer reset		Reset	No operation	–	W	being read	
D0	TMRUN	Clock timer Run/Stop control		Run	Stop	0	R/W		

**Specifications****Control of output port (R port)****(1) *initoutput\_normal, output\_normal*: Normal DC output**

Sets the R3x port to complementary output and outputs HIGH and LOW to R35–R37.

**(2) *init\_hiz, output\_hiz*: High impedance output control**

First sets the R5x port to complementary output and then switches between high impedance output and complementary output to operate the high impedance control register.

**(3) *fout\_init, fout\_control*: FOUT output control**

Controls the turning ON/OFF of the FOUT output.

**Notes**

- (1) Besides normal DC output, output port terminals are shared with the special output shown in Table 6.1, and which is used can be selected in software. When using special output, it should be noted so that the port cannot be used as output port.

For control of special output except for FOUT output (R34 terminal), see the following chapters:

- TOUT output (R27) ..... "12 PROGRAMMABLE TIMER"
- CL output (R25), FR output (R26) ..... "13 LCD CONTROLLER"
- BZ output (R50) ..... "14 SOUND GENERATOR"

- (2) Please note that in accordance with the bus mode and system controller settings or when using bus release for DMA transfer, the following output port terminals are used for the address bus,  $\overline{RD}/\overline{WR}$  signals, CE3–CE0 signals and BACK outputs and cannot be used as an output port.

- (3) R35–R37 terminals can be used only when the E0C883xx chip is being shipped.

- (4) The E0C88308 does not have R51 terminal.

Table 6.1 *Special output*

Output port	Special output
R25	CL output
R26	FR output
R27	TOUT output
R34	FOUT output
R50	BZ output

## 6 OUTPUT PORTS (R PORTS)

### Notes

Table 6.2  
Combined output terminal

Output port	Special output
R00–R07	A0–A7
R10–R17	A8–A15
R20–R22	A16–A18
R23	$\overline{RD}$ signal
R24	$\overline{WR}$ signal
R30–R33	$\overline{CE0}$ – $\overline{CE3}$ signals
R51	$\overline{BACK}$ signal

### Flowchart

#### (1) Normal DC output

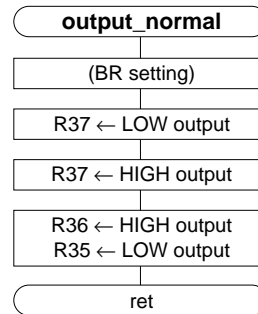
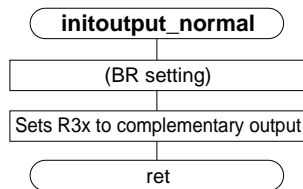

#### (2) High impedance output control

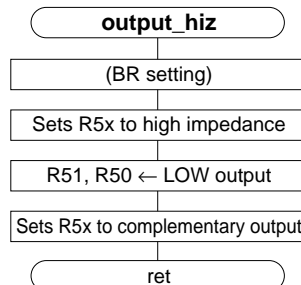
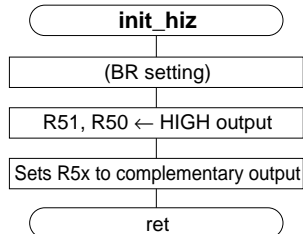

At this time, output shifts from HIGH to high impedance.

At this time, output shifts from high impedance to LOW.

#### (3) FOUT output control

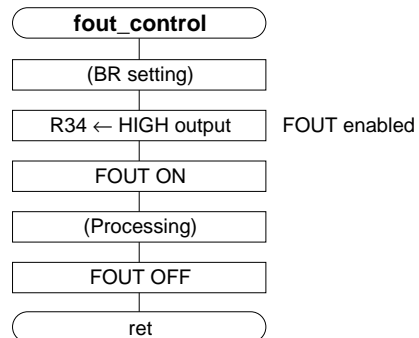
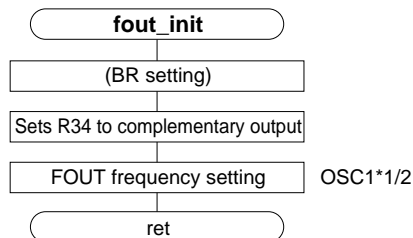

Note: The E0C88308 does not have R51 terminal.

## Source List

**Control of output port (R port)**

```

        public      initoutput_normal,output_normal
        public      init_hiz,output_hiz
        public      fout_init,fout_control
;
br_io          equ    0ffh                ;base reg. address (set i/o area)
hizr_ex       equ    00ff70h             ;expand output control reg.
hizr3         equ    00ff72h             ;r3x output control reg.
r3d           equ    00ff76h             ;r3x output data
r5d           equ    00ff78h             ;r5x output data
rtm_mode      equ    00ff40h             ;timer mode set reg.
        code

```

**(1) Normal DC output**

```

;*****
;*
;*      r(output) port control (normal)
;*      r37 <- "1" then "h"      (complementary)
;*      r36,35 <- "h","1"      (complementary)
;*
;*****
;*** initialize routine
initoutput_normal:
        ld      br,#br_io                ;set br reg. address to 0ffxxh
        ld      [br:low hizr3],#00000000b ;set r3x complementary output
        ret
;*****
;*** control routine
output_normal:
        ld      br,#br_io                ;set br reg. address to 0ffxxh
        and     [br:low r3d],#01111111b  ;r37 <- "1" output
        or      [br:low r3d],#10000000b  ;r37 <- "h" output
        ld      a,[br:low r3d]           ;r3x output port read
        and     a,#10011111b
        or      a,#01000000b
        ld      [br:low r3d],a          ;r36 <- "h" and r35 <- "1" output
        ret

```

(1)

**(2) High impedance output control**

```

;*****
;*
;*      r(output) port control (hi-z)
;*      r50,51 <- "h","h"      (complementary at init.)
;*
;*      <- "hi-z"
;*      <- "1","1"            (complementary)
;*
;*****
;*** initialize routine
init_hiz:
        ld      br,#br_io                ;set br reg. address to 0ffxxh
        or      [br:low r5d],#00000011b  ;r51,50 <- "h"
        and     [br:low hizr_ex],#00111111b ;r5x <- complementary output
        ret
;*****
;*** control routine
output_hiz:
        ld      br,#br_io                ;set br reg. address to 0ffxxh
        or      [br:low hizr_ex],#11000000b ;r5x <- high impedance ("hi-z")
        and     [br:low r5d],#11111100b  ;r51,50 <- "1" output
        and     [br:low hizr_ex],#00111111b ;r5x <- complementary output
        ret
;

```

(2)

## Source List

**(3) FOUT output control**

```

;*****
;*
;*      fout control
;*
;*****
;*** initialize routine
fout_init:
    ld    br,#br_io                ;set br reg. address to 0ffxxh
    and   [br:low hzr3],#11110111b ;set r34 complementary output
    ld    a,[br:low rtm_mode]
    and   a,#00000111b
    or    a,#00010000b            ;set fout=fosc1/2
    ld    [br:low rtm_mode],a
    ret
;*****
;*** control routine
fout_control:
    or    [br:low r3d],#00010000b   ;r34="h" (fout enable)
    or    [br:low rtm_mode],#00001000b ;fout on
;
;
;other processing
;
;
    and   [br:low rtm_mode],#11110111b ;fout off
    ret
;
    end

```

(3)

# 7 I/O PORTS (P PORTS)

## I/O Map

Address	Bit	Name	Function	1	0	SR	R/W	Comment
00FF60	D7	IOC07	P07 I/O control register	Output	Input	0	R/W	
	D6	IOC06	P06 I/O control register					
	D5	IOC05	P05 I/O control register					
	D4	IOC04	P04 I/O control register					
	D3	IOC03	P03 I/O control register					
	D2	IOC02	P02 I/O control register					
	D1	IOC01	P01 I/O control register					
	D0	IOC00	P00 I/O control register					
00FF61	D7	IOC17	P17 I/O control register	Output	Input	0	R/W	
	D6	IOC16	P16 I/O control register					
	D5	IOC15	P15 I/O control register					
	D4	IOC14	P14 I/O control register					
	D3	IOC13	P13 I/O control register					
	D2	IOC12	P12 I/O control register					
	D1	IOC11	P11 I/O control register					
	D0	IOC10	P10 I/O control register					
00FF62	D7	P07D	P07 I/O port data	High	Low	1	R/W	
	D6	P06D	P06 I/O port data					
	D5	P05D	P05 I/O port data					
	D4	P04D	P04 I/O port data					
	D3	P03D	P03 I/O port data					
	D2	P02D	P02 I/O port data					
	D1	P01D	P01 I/O port data					
	D0	P00D	P00 I/O port data					
00FF63	D7	P17D	P17 I/O port data	High	Low	1	R/W	
	D6	P16D	P16 I/O port data					
	D5	P15D	P15 I/O port data					
	D4	P14D	P14 I/O port data					
	D3	P13D	P13 I/O port data					
	D2	P12D	P12 I/O port data					
	D1	P11D	P11 I/O port data					
	D0	P10D	P10 I/O port data					

Specifications

**Control of I/O port (P port)**

**(1) initio\_normal, io\_normal: Normal data input/output of I/O port**

Sets P0x port as input and P1x port as output, and then waits for a HIGH input to P07 port. When P07 shifts to HIGH, reads P0x input data and outputs 55H to P1x.

**(2) init\_switch, io\_switch: Scan for 2 x 2 switch matrix**

Assumes the switch matrix has been configured with input and output as shown in Figure 7.1, and specifies the key pressed and then stores the data into the RAM area named switch\_data.

<Conditions>

P10, P11 ports: Input with pull-up resistor

R51, R50 ports: Nch open drain output (software setting)

switch\_data: 1 byte

	7	6	5	4	3	2	1	0
switch_data	0	0	0	0	P11 R51	P10 R51	P11 R50	P10 R50

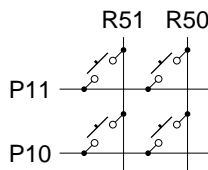
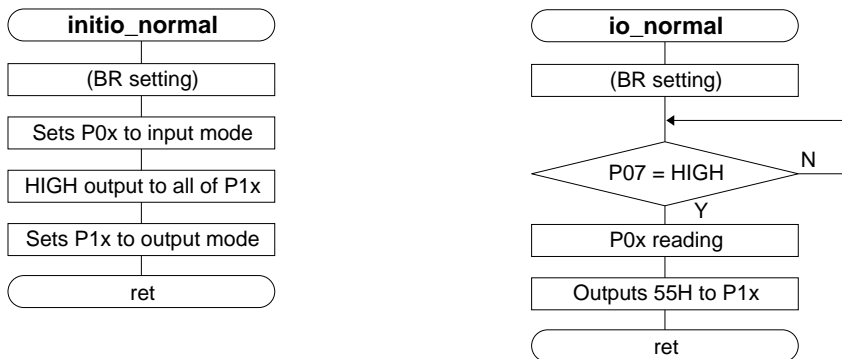

Fig. 7.1 Switch matrix

Flowchart

**(1) Normal data input/output of I/O port**



## Flowchart

## (2) Scan for 2 x 2 switch matrix

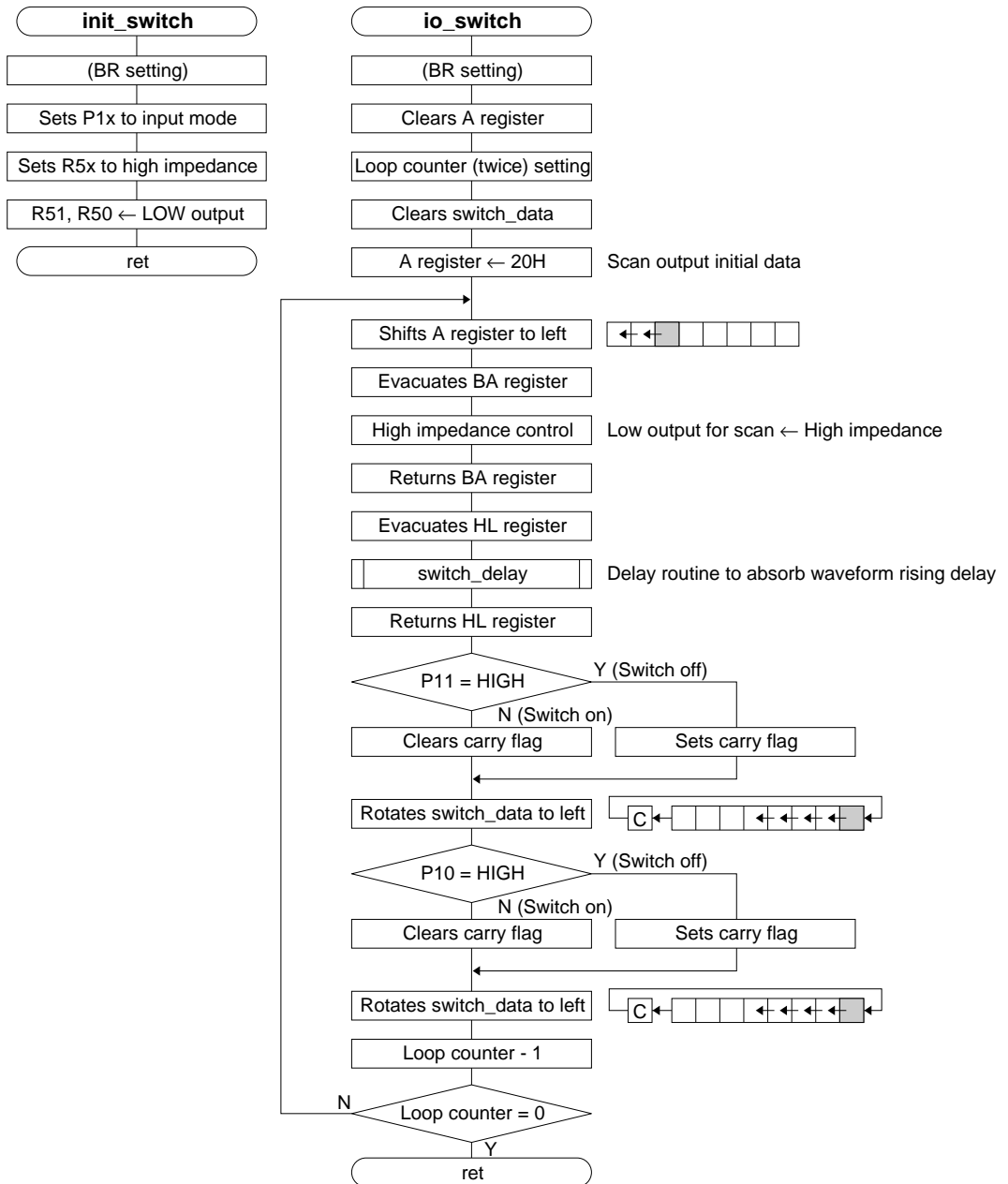



Notes

- (1) In the input mode, when changing the port terminal from LOW to HIGH with a pull-up resistor, a delay in the waveform rise time will occur depending on the time constant of the pull-up resistor and input gate capacity. Hence, when reading data from the input port, set an appropriate wait time (for reference, approximately 500 μsec). Care is particularly required in key scanning for key matrix configuration. (external call: switch\_delay)
- (2) Besides normal DC output, I/O port terminals are shared with the special output shown in Table 7.1, and which is used can be selected in software. When using special output, it should be noted so that the port cannot be used as I/O port.

Table 7.1 Special input/output

I/O port	Special output
P10	SIN
P11	SOUT
P12	SCLK
P13	SRDY
P14	CMPP0
P15	CMPM0
P16	CMPP1
P17	CMPM1

For details of each control procedure, see the following chapters:

- SIN (P10), SOUT (P11), SCLK (P12), SRDY (P13)  
 ..... "8 SERIAL INTERFACE 1 (CLOCK SYNCHRONOUS SYSTEM)"  
 ..... "9 SERIAL INTERFACE 2 (ASYNCHRONOUS SYSTEM)"
- CMPP0 (P14), CMPM0 (P15), CMPP1 (P16), CMPM1 (P17)  
 ..... "15 ANALOG COMPARATOR"

- (3) Please note that in accordance with the bus mode and system controller settings, P0x terminals are used for the data bus and cannot be used as an I/O port.

Table 7.2 Combined data bus terminal

I/O port	Special output
P00–P07	D0–D7

## Source List

**Control of I/O port (P port)**

```

        external      switch_delay
        public        initio_normal,io_normal
        public        init_switch,io_switch
        public        switch_data
;
br_io      equ      0ffh                ;base reg. address (set i/o area)
ioc0      equ      00ff60h            ;p0x i/o control reg.
ioc1      equ      00ff61h            ;plx i/o control reg.
p0d       equ      00ff62h            ;p0x port data
p1d       equ      00ff63h            ;plx port data
hxr_ex    equ      00ff70h            ;expand output control reg.
r5d       equ      00ff78h            ;r5x output data
;
        data
switch_data: db      [1]
;
        code

```

**(1) Normal data input/output of I/O port**

```

;*****
;*
;*      p(i/o) port control (normal)                *
;*      p0x (input:gate direct)                    *
;*      plx (output) <- p17-10 (all "h")           *
;*
;*      p07 (input) <- waits "l" to "h" then p0x data read *
;*      p0x (input) <- p0x port data read          *
;*
;*****
;*** initialize routine
initio_normal:
        ld      br,#br_io                ;set br reg. address to 0ffxxh
        ld      [br:low ioc0],#00000000b        ;set ioc0 (p07-00=input)
        ld      [br:low p1d],#11111111b        ;p17-10(output) <- "h"
        ld      [br:low ioc1],#11111111b        ;set ioc1 (p17-10=output)
        ret
;*****
;*** control routine
io_normal:
        ld      br,#br_io                ;set br reg. address to 0ffxxh
io_normal00:
        bit     [br:low p0d],#10000000b        ;p07 = "h" ?
        jrs     z,io_normal00
;
        ld      a,[br:low p0d]                ;p0x input
        ld      [br:low p1d],#01010101b        ;plx output
;
        ret

```

(1)

## Source List

**(2) Scan for 2 x 2 switch matrix**

```

;*****
;*
;*      p(i/o) port control (internal pull up delay)
;*      r51  r50(n-channel open drain)
;*      p11(pull up)
;*      p10(pull up)
;*
;*      switch data  7  6  5  4   3   2   1   0
;*
;*
;*****
;*** initialize routine
init_switch:
    ld    br,#br_io          ;set br reg. address to 0ffxxh
    ld    [br:low iocl],#00000000b ;set iocl (p17-10=input)
    or    [br:low hzr_ex],#11000000b ;r5x <- high impedance "hi-z"
    and   [br:low r5d],#11111100b   ;r5x <- "1"
    ret
;*****
;*** control routine
io_switch:
    ld    br,#br_io          ;set br reg. address to 0ffxxh
    xor   a,a
    ld    b,#2
    ld    hl,#lod switch_data ;switch scan loop counter
    ld    [hl],#0            ;switch data buffer
    ld    a,#00100000b      ;clear switch data buffer
                                ;scan init. data set
switch00:
    sll   a                  ;scan data move bit0 to 7
    push  ba
    ld    b,[br:low hzr_ex]  ;escape scan data
    and   b,#00111111b      ;r5x hi-z control ("hi-z" <-> "1")
    or    a,b
    ld    [br:low hzr_ex],a  ;r5x scan data control with hi-z
    pop   ba
    push  hl
    carl  switch_delay      ;switch scan delay ***
    pop   hl
    bit   [br:low p1d],#00000010b ;compare p11 port level
    jrs   nz,switch01
;switch (p11) on "1"
    and   sc,#11111101b    ;clear carry flag
    jrs   switch02
;switch (p11) off "h"
switch01:
    or    sc,#00000010b    ;set carry flag
switch02:
    rl    [hl]
    bit   [br:low p1d],#00000001b ;compare p10 port level
    jrs   nz,switch03
;switch (p10) on "1"
    and   sc,#11111101b    ;clear carry flag
    jrs   switch04
;switch (p10) off "h"
switch03:
    or    sc,#00000010b    ;set carry flag
switch04:
    rl    [hl]
    djr  nz,switch00
;
    ret
;
    end

```

(2)

# 8 SERIAL INTERFACE 1

## (CLOCK SYNCHRONOUS INTERFACE)

## I/O Map

Address	Bit	Name	Function	1	0	SR	R/W	Comment		
00FF48	D7	–	–	–	–	–		"0" when being read		
	D6	EPR	Parity enable register	With parity	Non parity	0	R/W	Only for		
	D5	PMD	Parity mode selection	Odd	Even	0	R/W	asynchronous mode		
	D4	SCS1	Clock source selection				0	R/W	In the clock synchronous slave mode, external clock is selected.	
			SCS1	SCS0						Clock source
			1	1						Programmable timer
	D3		SCS0	1						0
		0		1	fosc3 / 8					
	0	0		fosc3 / 16						
D2	SMD1	Serial I/F mode selection				0	R/W			
		SMD1	SMD0						Mode	
		1	1						Asynchronous 8-bit	
D1		SMD0	1						0	Asynchronous 7-bit
	0		1	Clock synchronous slave						
	0		0	Clock synchronous master						
D0	ESIF	Serial I/F enable register		Serial I/F	I/O port	0	R/W			
00FF49	D7	–	–	–	–	–		"0" when being read		
	D6	FER	Framing error flag	R	Error	No error	0	R/W	Only for asynchronous mode	
				W	Reset (0)	No operation				
	D5	PER	Parity error flag	R	Error	No error	0	R/W		
				W	Reset (0)	No operation				
	D4	OER	Overrun error flag	R	Error	No error	0	R/W		
				W	Reset (0)	No operation				
	D3	RXTRG	Receive trigger/status	R	Run	Stop	0	R/W		
	W			Trigger	No operation					
D2	RXEN	Receive enable		Enable	Disable	0	R/W			
D1	TXTRG	Transmit trigger/status	R	Run	Stop	0	R/W			
			W	Trigger	No operation					
D0	TXEN	Transmit enable		Enable	Disable	0	R/W			
00FF4A	D7	TRXD7	Transmit/Receive data D7 (MSB)		High	Low	X	R/W		
	D6	TRXD6	Transmit/Receive data D6							
	D5	TRXD5	Transmit/Receive data D5							
	D4	TRXD4	Transmit/Receive data D4							
	D3	TRXD3	Transmit/Receive data D3							
	D2	TRXD2	Transmit/Receive data D2							
	D1	TRXD1	Transmit/Receive data D1							
	D0	TRXD0	Transmit/Receive data D0 (LSB)							
00FF20	D7	PK01	K00–K07 interrupt priority register	PK01	PK00	0	R/W			
	D6	PK00								
	D5	PSIF1	Serial interface interrupt priority register	PSIF1	PSIF0	Priority level	0	R/W		
	D4	PSIF0								
	D3	PSW1								
	D2	PSW0	Stopwatch timer interrupt priority register	1	1	Level 3	0	R/W		
			1	0	Level 2					
		0	1	Level 1						
D1	PTM1	Clock timer interrupt priority register	0	0	Level 0	0	R/W			
D0	PTM0									

## 8 SERIAL INTERFACE 1 (CLOCK SYNCHRONOUS INTERFACE)

### I/O Map

Address	Bit	Name	Function	1	0	SR	R/W	Comment
00FF23	D7	EPT1	Programmable timer 1 interrupt enable register	Interrupt enable	Interrupt disable	0	R/W	
	D6	EPT0	Programmable timer 0 interrupt enable register					
	D5	EK1	K10 and K11 interrupt enable register					
	D4	EK0H	K04–K07 interrupt enable register					
	D3	EK0L	K00–K03 interrupt enable register					
	D2	ESERR	Serial I/F (error) interrupt enable register					
	D1	ESREC	Serial I/F (receiving) interrupt enable register					
D0	ESTRA	Serial I/F (transmitting) interrupt enable register						
00FF25	D7	FPT1	Programmable timer 1 interrupt factor flag	(R)	(R)	0	R/W	
	D6	FPT0	Programmable timer 0 interrupt factor flag	Interrupt factor is generated	No interrupt factor is generated			
	D5	FK1	K10 and K11 interrupt factor flag					
	D4	FK0H	K04–K07 interrupt factor flag					
	D3	FK0L	K00–K03 interrupt factor flag	(W) Reset	(W) No operation			
	D2	FSERR	Serial I/F (error) interrupt factor flag					
	D1	FSREC	Serial I/F (receiving) interrupt factor flag					
D0	FSTRA	Serial I/F (transmitting) interrupt factor flag						

### Specifications

#### Clock synchronous serial interface

##### <Conditions>

P10: SIN	(Input)	Function and input/output direction of the I/O port are automatically decided when setting the serial mode.
P11: SOUT	(Output)	
P12: SCLK	(Output)	
P13: Slave READY	(Input)	Hand shake signal from slave side

#### Vector address setting for serial interface interrupt

##### (1) *sio\_init*: Initialization for clock synchronous serial interface (master mode)

Sets the following in order to transmit/receive in a clock synchronous system:

- Serial interface function
- Normal mode (OSC3 oscillation)
- Clock synchronous master mode
- Transmitting/receiving interrupt enable ( $\overline{\text{IRQ2}}$ )
- Synchronous clock  $\text{OSC3} \times 1/4$

##### (2) *siorv, siorv\_intr*: Receiving of clock synchronous serial interface (master mode)

Checks handshake signal (P13) and stores a total of 256 bytes of received data from the slave into a built-in memory receive\_buffer one byte at a time, using the receiving interrupt ( $\overline{\text{IRQ2}}$ ).

##### (3) *siotr, siotr\_intr*: Transmitting of clock synchronous serial interface (master mode)

Checks handshake signal (P13) and outputs a total of 256 bytes of transmitted data from a built-in memory trans\_buffer to the slave one byte at a time, using the transmitting interrupt ( $\overline{\text{IRQ2}}$ ).

**Notes**

- (1) External routines are called for switching to OSC3 and OSC1. (external call: osc1toosc3, osc3toosc1)
- (2) Switching the operating mode when the supply voltage is lower than the VD1 setting may cause a malfunction. Hence, the example routine checks the supply voltage when switching to the normal mode (OSC3) and terminates as a supply voltage error remains unprocessed if the supply voltage is lower than the VD1 setting. For this determination, vdd\_ngf flag is used. (See "4 OSCILLATION CIRCUIT".)
- (3) When switching from OSC3 to OSC1 ( $V_{D1} = 2.2\text{ V} \rightarrow 1.3\text{ V}$ ), the program example does not perform special checking of the supply voltage of SVD if the supply voltage is already more than the VD1 setting.
- (4) To reset the interrupt factor flag, write "1" into the corresponding flags alone, using the AND or LD instruction. When the OR logic operation instruction has been used, "1" is written for the interrupt factor flags that have been set to "1" within the same address and those flags are then clear.
- (5) The interrupt flags (I1 and I0) have not been reset in the interrupt processing routine of this program example, so an interrupt lower than IRQ2 level is disabled at the time of generation. When you wish to accept the next interrupt after an interrupt has been generated, re-setting of the interrupt flags or resetting the interrupt factor flag is necessary after due consideration for the nesting level.
- (6) When you have written "1" for the transmitting/receiving trigger and begin transmitting/receiving, first read the data and be sure to write "1" only on the necessary bits.  
Another transmitting/receiving status (receiving status during transmitting, and transmitting status during receiving) has been allocated for reading to the same address as the transmitting/receiving triggers. For example, when directly writing to the transmitting trigger, using the OR instruction during a receiving operation (receiving status = "1"), the receiving status is read once and it is then written as the receiving trigger. It is the same as the current receiving trigger.
- (7) In this program example for serial interface 1 (clock synchronous system), the vector address setting and program have been allocated from 003000H for the sake of convenience.

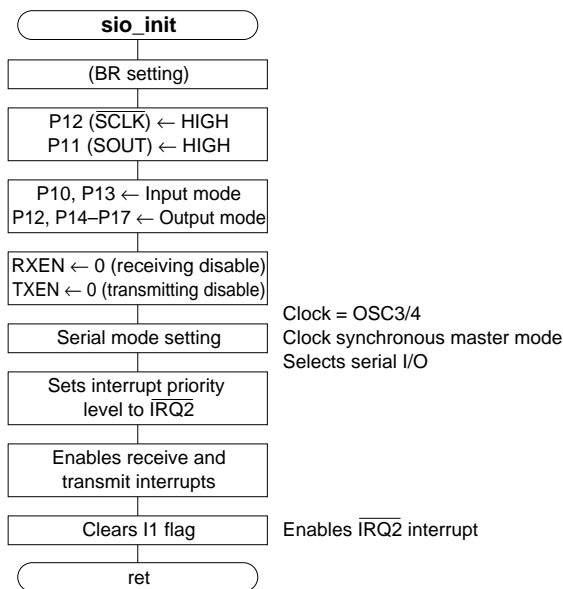
**Flowchart****(1) Initialization for clock synchronous serial interface (master mode)**

Flowchart

(2) Receiving of clock synchronous serial interface (master mode)

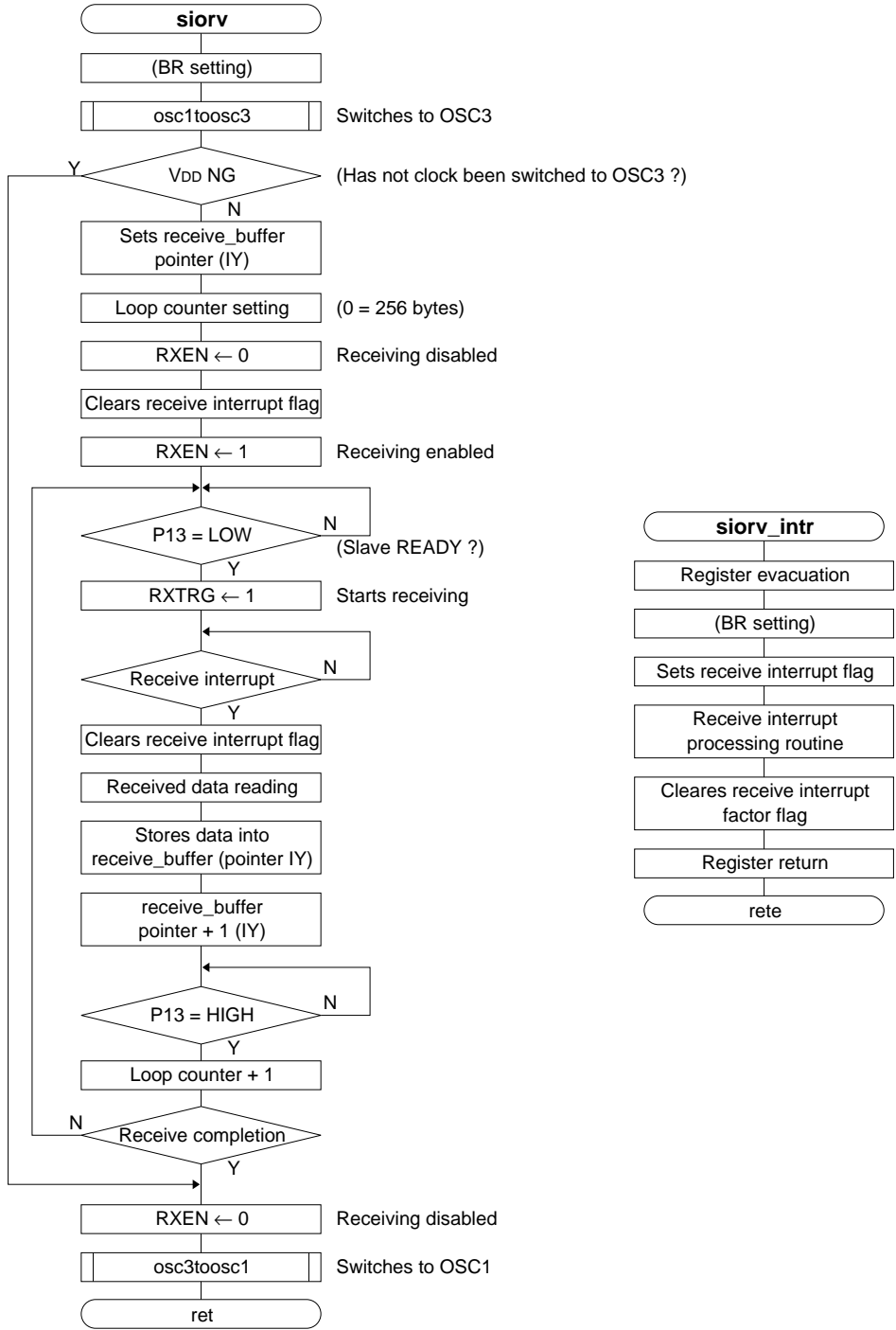

Flowchart

(3) Transmitting of clock synchronous serial interface (master mode)

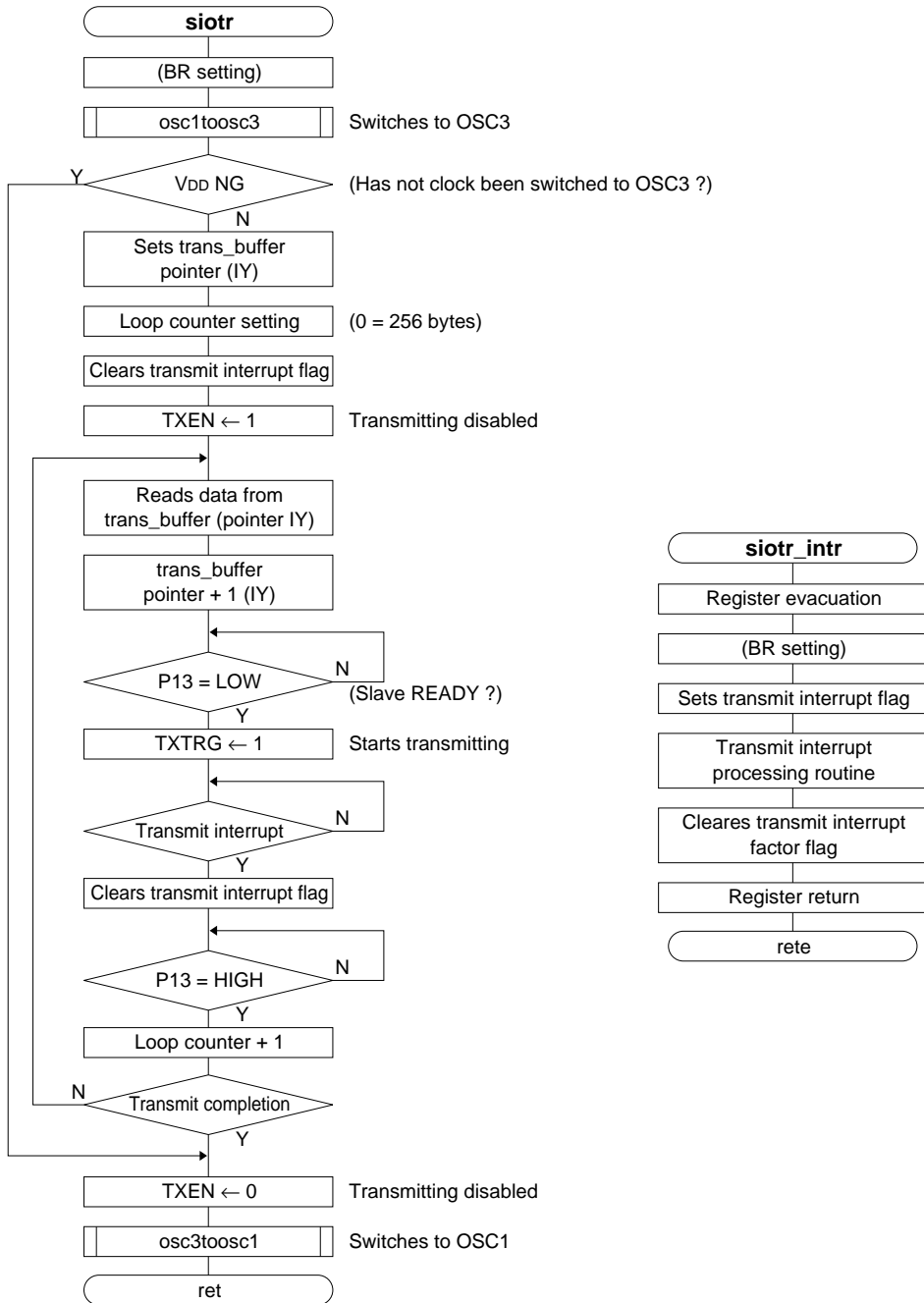



## Source List

**Clock synchronous serial interface**

```

        external    osc1toosc3,osc3toosc1
        external    vdd_ngf
        public      sio_init,siorv,siotr,siorv_intr,siotr_intr
        public      receive_buffer,trans_buffer,receive_flag,trans_flag
;
siorv_vector    equ    000012h                ;sio receive interrupt vector offset
siotr_vector    equ    000014h                ;sio trans interrupt vector offset
sio             equ    003000h                ;program start address offset
br_io          equ    0ffh                    ;base reg. address (set i/o area)
mode           equ    00ff02h                ;mode control reg.
ioc1           equ    00ff61h                ;plx i/o control reg.
pld            equ    00ff63h                ;plx port data
smd            equ    00ff48h                ;serial interface mode set reg.
ser            equ    00ff49h                ;serial interface error and trigger reg
trxd           equ    00ff4ah                ;trans/recive data reg.
intr_pr0       equ    00ff20h                ;interrupt priority reg. 0
intr_en1       equ    00ff23h                ;interrupt enable reg. 1
intr_fac1      equ    00ff25h                ;interrupt factor reg. 1
;
        data
receive_buffer: db    [256]                  ;sio receive buffer
trans_buffer:   db    [256]                  ;sio trans buffer
receive_flag:   db    [1]                   ;trans complete flag
trans_flag:     db    [1]                   ;receive complete flag
        code

```

**Vector address setting for serial interface interrupt**

```

intr_vectors:
;
        org      intr_vectors+siorv_vector
        dw      siorv_intr                    ;sio receive interrupt
;
        org      intr_vectors+siotr_vector
        dw      siotr_intr                    ;sio trans interrupt
;

```

**(1) Initialization for clock synchronous serial interface (master mode)**

```

        org      intr_vectors+sio
;*****
;*
;*      sio master mode initialize (p13=slave ready)
;*
;*****
;*** initialize routine
sio_init:
;p17-14=programmable output,p13=slave ready,p12-10=sio terminal
        ld      br,#br_io                    ;set br reg. address to 0ffxxh
        ld      [br:low pld],#11110110b      ;/sclk="h",sout="h"
        ld      [br:low ioc1],#11110110b
        ld      [br:low ser],#01110000b      ;rxen=dis.txen=dis.
;serial mode:no-parity,clock=fosc3/4,sio master mode and serial i/o select
        ld      [br:low smd],#00010001b      ;set serial interface mode
        ld      a,[br:low intr_pr0]          ;interrupt priority reg.
        and     a,#11001111b
        or      a,#00100000b
        ld      [br:low intr_pr0],a          ;set psif1,0 to /irq2
        ld      a,[br:low intr_en1]
        and     a,#01111000b
        or      a,#00000011b
        ld      [br:low intr_en1],a          ;esrec and estra intr. en.

        ld      a,sc
        and     a,#00111111b
        or      a,#01000000b
        ld      sc,a                          ;il flag clear (en. /irq2 intr.)
        ret

```

(1)

## Source List

**(2) Receiving of clock synchronous serial interface (master mode)**

```

;*****
;*
;*      sio master mode receive (p13=slave ready)
;*
;*****
;*** control routine
siorv:
    ld    br,#br_io                ;set br reg. address to 0ffxxh
    carl  osc1toosc3              ;change osc1 to osc3 ***
    ld    a,[lod vdd_ngf]         ;vdd ng flag
    cp    a,#0ffh
    jrl   z,siorv02              ;vdd error
;
    ld    iy,#lod receive_buffer  ;receive data buffer
    ld    b,#0                    ;set receive counter (00h=256)
    ld    a,[br:low ser]
    and   a,#00000001b
    ld    [br:low ser],a
    xor   a,a
    ld    [lod receive_flag],a   ;sio receive interrupt flag clear
    ld    a,[br:low ser]
    and   a,#00000001b
    or    a,#00000100b
    ld    [br:low ser],a        ;rxen=1 (en.)
;
;wait slave ready
siorv00:
    bit   [br:low pld],#00001000b ;p13(slave ready)="1
    jrs   nz,siorv00
;
    ld    a,[br:low ser]
    and   a,#00000101b
    or    a,#00001000b
    ld    [br:low ser],a        ;rxtrg=set
;wait sio receive interrupt
siorv01:
    ld    a,[lod receive_flag]    ;sio receive interrupt flag
    cp    a,#0ffh
    jrs   nz,siorv01
;
    xor   a,a
    ld    [lod receive_flag],a   ;clear sio receive interrupt flag
    ld    a,[br:low trxd]
    ld    [iy],a                 ;receive data read
    ld    [iy],a                 ;set receive data buffer
siorv03:
    bit   [br:low pld],#00001000b
    jrs   z,siorv03
    inc   iy                      ;receive buffer + 1
    djr   nz,siorv00             ;until buffer end (256 bytes)
;
siorv02:
    ld    a,[br:low ser]
    and   a,#00000001b
    ld    [br:low ser],a        ;rxen=0 (dis.) sio reset
    carl  osc3toosc1            ;change osc3 to osc1 ***
    ret

```

(2)

## 8 SERIAL INTERFACE 1 (CLOCK SYNCHRONOUS INTERFACE)

### Source List

#### (3) Transmitting of clock synchronous serial interface (master mode)

```
*****
;*
;*      sio master mode trans (p13=slave ready)
;*
;*
*****
*** control routine
siotr:
    ld    br,#br_io                ;set br reg. address to 0ffxxh
    carl  osc1toosc3              ;change osc1 to osc3 ***
    ld    a,[lod vdd_ngf]         ;vdd ng flag
    cp    a,#0ffh
    jrl   z,siotr03              ;vdd error
;
    ld    iy,#lod trans_buffer    ;trans data buffer
    ld    b,#0                    ;set trans counter (00h=256)
    ld    a,[br:low ser]
    and   a,#00000100b
    ld    [br:low ser],a         ;txen=0 (dis.) sio reset
    xor   a,a
    ld    [lod trans_flag],a     ;sio trans interrupt flag clear
    ld    a,[br:low ser]
    and   a,#00000100b
    or    a,#00000001b
    ld    [br:low ser],a         ;txen=en.
;wait slave ready
siotr00:
    ld    a,[iy]                  ;load trans data buffer
    ld    [br:low trxd],a         ;set trans data
    inc   iy                      ;trans buffer + 1
;
siotr02:
    bit   [br:low p1d],#00001000b ;p13(slave ready)="1"
    jrs   nz,siotr02
;
    ld    a,[br:low ser]
    and   a,#00000101b
    or    a,#00000010b
    ld    [br:low ser],a         ;txtrg=set
;wait sio trans interrupt
siotr01:
    ld    a,[lod trans_flag]     ;sio trans interrupt flag
    cp    a,#0ffh
    jrs   nz,siotr01
;
    xor   a,a
    ld    [lod trans_flag],a     ;clear sio trans interrupt flag
siotr04:
    bit   [br:low p1d],#00001000b
    jrs   z,siotr04
    djr   nz,siotr00             ;until buffer end (256 bytes)
;
siotr03:
    ld    a,[br:low ser]
    and   a,#00000100b
    ld    [br:low ser],a         ;txen=0 (dis.) sio reset
    carl  osc3toosc1             ;change osc3 to osc1 ***
    ret
```

(3)

## Source List

**(2) Receiveing interrupt**

```

;*****
;*
;*      sio master mode receive interrupt processing routine      *
;*
;*****
siorv_intr:
    push  ale
;
    ld    br,#br_io          ;set br reg. address to 0ffxxh
;
    ld    a,#0ffh
    ld    [lod receive_flag],a      ;set sio receive interrupt flag
;
;
;      sio receive interrupt processing routine
;
;
    and   [br:low intr_fac1],#00000010b  ;clear fsrec flag
    pop   ale
    rete

```

(2)

**(3) Transmitting interrupt**

```

;*****
;*
;*      sio master trans interrupt processing routine      *
;*
;*****
siotr_intr:
    push  ale
;
    ld    br,#br_io          ;set br reg. address to 0ffxxh
;
    ld    a,#0ffh
    ld    [lod trans_flag],a      ;set sio trans interrupt flag
;
;
;      sio trans interrupt processing routine
;
;
    and   [br:low intr_fac1],#00000001b  ;clear fstra flag
    pop   ale
    rete
;
    end

```

(3)

# 9 SERIAL INTERFACE 2 (ASYNCHRONOUS INTERFACE)

## I/O Map

Address	Bit	Name	Function	1	0	SR	R/W	Comment		
00FF48	D7	–	–	–	–	–		"0" when being read		
	D6	EPR	Parity enable register	With parity	Non parity	0	R/W	Only for asynchronous mode		
	D5	PMD	Parity mode selection	Odd	Even	0	R/W			
	D4	SCS1	Clock source selection	SCS1 SCS0 Clock source		0	R/W	In the clock synchronous slave mode, external clock is selected.		
				1	1				Programmable timer	
	D3			SCS0	1				0	fosc3 / 4
		0	1		fosc3 / 8					
		0	0		fosc3 / 16					
D2	SMD1	Serial I/F mode selection	SMD1 SMD0 Mode		0	R/W				
			1	1			Asynchronous 8-bit			
D1	SMD0		1	0	Asynchronous 7-bit	0	R/W			
			0	1	Clock synchronous slave					
	0	0	Clock synchronous master							
D0	ESIF	Serial I/F enable register	Serial I/F	I/O port	0	R/W				
00FF49	D7	–	–	–	–	–		"0" when being read		
	D6	FER	Framing error flag	R	Error	No error	0	R/W	Only for asynchronous mode	
				W	Reset (0)	No operation				
	D5	PER	Parity error flag	R	Error	No error	0	R/W		
				W	Reset (0)	No operation				
	D4	OER	Overrun error flag	R	Error	No error	0	R/W		
				W	Reset (0)	No operation				
	D3	RXTRG	Receive trigger/status	R	Run	Stop	0	R/W		
	W			Trigger	No operation					
D2	RXEN	Receive enable	Enable	Disable	0	R/W				
D1	TXTRG	Transmit trigger/status	R	Run	Stop	0	R/W			
			W	Trigger	No operation					
D0	TXEN	Transmit enable	Enable	Disable	0	R/W				
00FF4A	D7	TRXD7	Transmit/Receive data D7 (MSB)	High	Low	X	R/W			
	D6	TRXD6	Transmit/Receive data D6							
	D5	TRXD5	Transmit/Receive data D5							
	D4	TRXD4	Transmit/Receive data D4							
	D3	TRXD3	Transmit/Receive data D3							
	D2	TRXD2	Transmit/Receive data D2							
	D1	TRXD1	Transmit/Receive data D1							
	D0	TRXD0	Transmit/Receive data D0 (LSB)							
00FF20	D7	PK01	K00–K07 interrupt priority register	PK01 PK00	PSIF1 PSIF0	PSW1 PSW0	PTM1 PTM0	Priority level	0	R/W
	D6	PK00								
	D5	PSIF1	Serial interface interrupt priority register	1 1	Level 3	0 0	Level 2	0	R/W	
	D4	PSIF0								
	D3	PSW1								
	D2	PSW0	Stopwatch timer interrupt priority register	1 0	Level 2	0 1	Level 1	0	R/W	
	D1	PTM1	Clock timer interrupt priority register	0 0	Level 0	0	R/W			
D0	PTM0									

**I/O Map**

Address	Bit	Name	Function	1	0	SR	R/W	Comment
00FF23	D7	EPT1	Programmable timer 1 interrupt enable register	Interrupt enable	Interrupt disable	0	R/W	
	D6	EPT0	Programmable timer 0 interrupt enable register					
	D5	EK1	K10 and K11 interrupt enable register					
	D4	EK0H	K04–K07 interrupt enable register					
	D3	EK0L	K00–K03 interrupt enable register					
	D2	ESERR	Serial I/F (error) interrupt enable register					
	D1	ESREC	Serial I/F (receiving) interrupt enable register					
	D0	ESTRA	Serial I/F (transmitting) interrupt enable register					
00FF25	D7	FPT1	Programmable timer 1 interrupt factor flag	(R)	(R)	0	R/W	
	D6	FPT0	Programmable timer 0 interrupt factor flag	Interrupt factor is generated	No interrupt factor is generated			
	D5	FK1	K10 and K11 interrupt factor flag					
	D4	FK0H	K04–K07 interrupt factor flag					
	D3	FK0L	K00–K03 interrupt factor flag					
	D2	FSERR	Serial I/F (error) interrupt factor flag	(W)	(W)			
	D1	FSREC	Serial I/F (receiving) interrupt factor flag	Reset	No operation			
	D0	FSTRA	Serial I/F (transmitting) interrupt factor flag					

**Specifications****Asynchronous serial interface**

## &lt;Conditions&gt;

- P10: SIN (Input) ] Function and input/output direction of the I/O port are automatically  
P11: SOUT (Output) ] decided when setting the serial mode.  
P12: Hand shake (Output) ] Unused  
P13: Hand shake (Input) ] (In this program example, handshake signals during transmission are ignored.)

**Vector address setting for serial interface interrupt****(1) *async\_init*: Initialization for asynchronous serial interface (8-bit mode)**

Sets the following in order to transmit/receive in an asynchronous system:

- Serial interface function
- Asynchronous 8-bit mode, even parity
- Synchronous clock = Programmable timer
- Normal mode (OSC3 oscillation)
- Transmitting/receiving interrupt enable ( $\overline{\text{IRQ2}}$ )

Transmission baud rate clock has been set to 9,600 bps (when OSC3 = 4.9152 MHz) using programmable timer 1 (8 bits).

**(2) *asynrcrv*, *asynrcrv\_intr*, *asyncerr\_intr*: Receiving of asynchronous serial interface (8-bit mode)**

Performs switching to the OSC3 clock and starting the programmable timer, and stores a total of 256 bytes of received data into the built-in memory receive\_buffer one byte at a time, using the receiving interrupt ( $\overline{\text{IRQ2}}$ ). At this time, if a receiving error occurs, it suspends receiving processing at that point.

**(3) *asynctr*, *asynctr\_intr*: Transmitting of asynchronous serial interface (8-bit mode)**

Performs switching to the OSC3 clock and starting the programmable timer, outputs a total of 256 bytes of transmitted data from a built-in memory trans\_buffer one byte at a time, using the transmitting interrupt ( $\overline{\text{IRQ2}}$ ).

### Notes

- (1) External routines are called for switching to OSC3 and OSC1. (external call: osc1toosc3, osc3toosc1)
- (2) Switching the operating mode when the supply voltage is lower than the VD1 setting may cause a malfunction. Hence, the example routine checks the supply voltage when switching to the normal mode (OSC3) and terminates as a supply voltage error remains unprocessed if the supply voltage is lower than the VD1 setting. For this determination, vdd\_ngf flag is used. (See "4 OSCILLATION CIRCUIT".)
- (3) When switching from OSC3 to OSC1 ( $VD1 = 2.2\text{ V} \rightarrow 1.3\text{ V}$ ), the program example does not perform special checking of the supply voltage of SVD if the supply voltage is already more than the VD1 setting.
- (4) The example routine does not check the handshake signal when transmitting/receiving. If this routine is used for an actual program, pay attention to the timing of transmitting/receiving, or check the timing using a handshake signal.
- (5) The 9,600 bps baud rate has been set on the condition that the 4.9152 MHz OSC3 oscillation clock is used.
- (6) To reset the interrupt factor flag, write "1" into the corresponding flags alone, using the AND or LD instruction. When the OR logic operation instruction has been used, "1" is written for the interrupt factor flags that have been set to "1" within the same address and those flags are then clear.
- (7) The interrupt flags (I1 and I0) have not been reset in the interrupt processing routine of this program example, so an interrupt lower than  $\overline{IRQ2}$  level is disabled at the time of generation. When you wish to accept the next interrupt after an interrupt has been generated, re-setting of the interrupt flags or resetting the interrupt factor flag is necessary after due consideration for the nesting level.
- (8) When you have written "1" for the transmitting/receiving trigger and begin transmitting/receiving, first read the data and be sure to write "1" only on the necessary bits.  
Also, when writing "1" to reset the receive error flag to "0", similar care is necessary.  
Another transmitting/receiving status (receiving status during transmitting, transmitting status during receiving, and receiving error flag) has been allocated for reading to the same address as the transmitting/receiving triggers. For example, when directly writing to the transmitting trigger, using the OR instruction during a receiving operation (receiving status = "1"), the receiving status is read once and it is then written as the receiving trigger.  
Also when the receiving error flag has been set to "1", the receiving error flag is written and reset by an OR instruction. It is the same as setting the receiving trigger or resetting the receiving error flag.
- (9) In this program example for serial interface 2 (asynchronous system), the vector address setting and program have been allocated from 003000H for the sake of convenience.

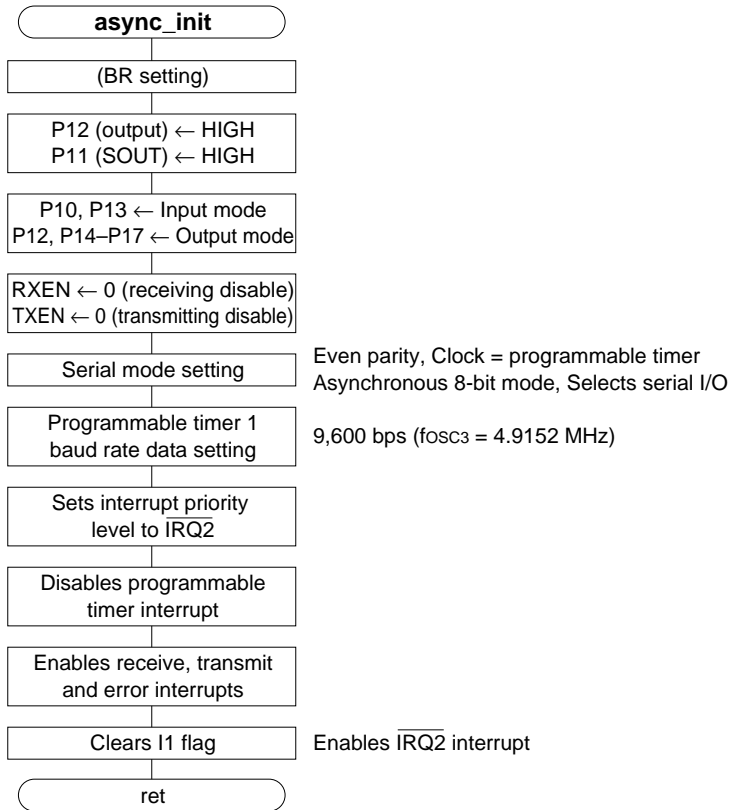
**Flowchart****(1) Initialization for asynchronous serial interface (8-bit mode)**



Flowchart

(2) Receiving of asynchronous serial interface (8-bit mode)

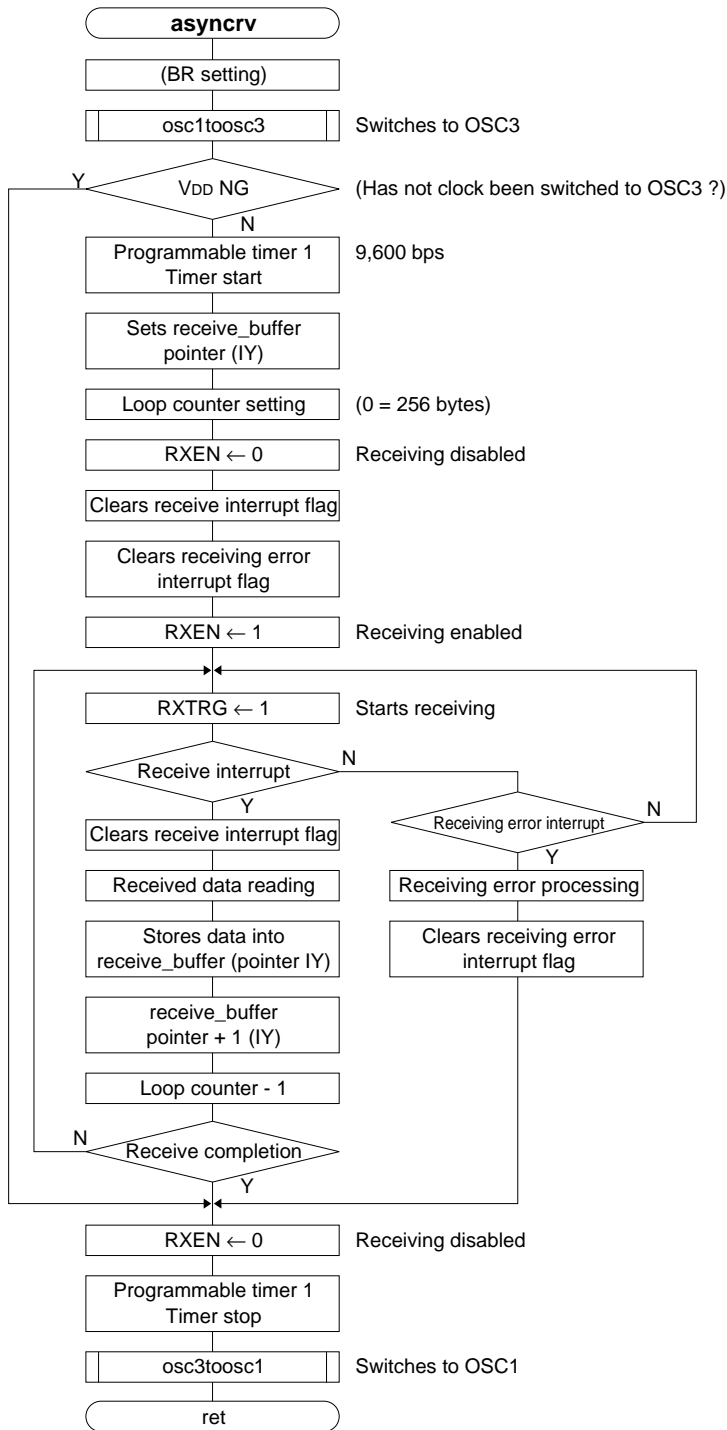

Flowchart

(3) Transmitting of asynchronous serial interface (8-bit mode)

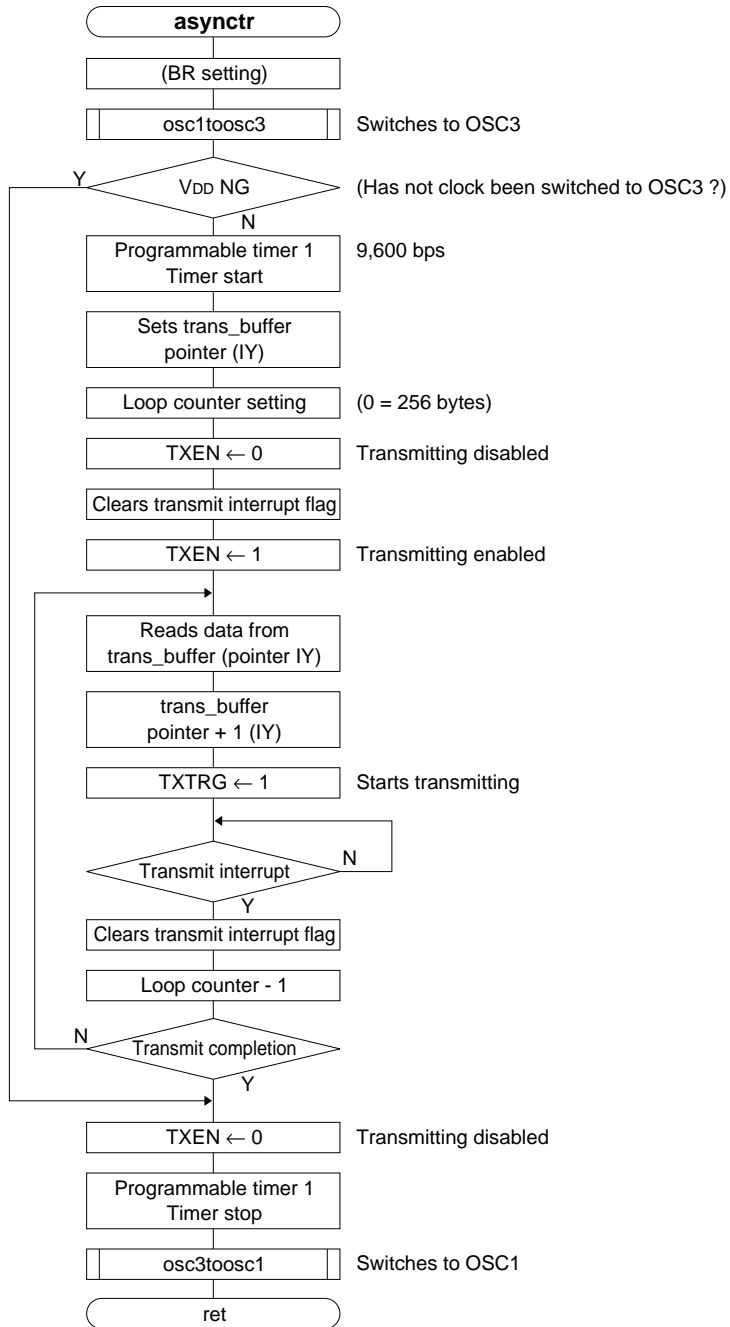

*Flowchart*

**(1) (2) (3) Interrupts of asynchronous serial interface (8-bit mode)**

**Receiving error interrupt**

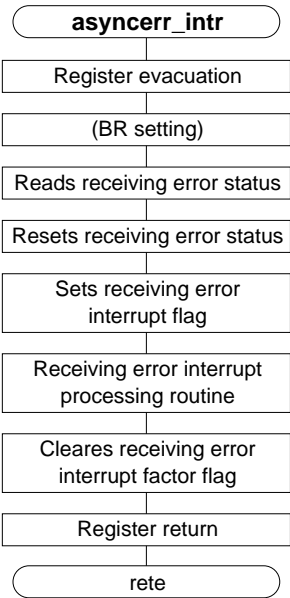

**Receiving interrupt**

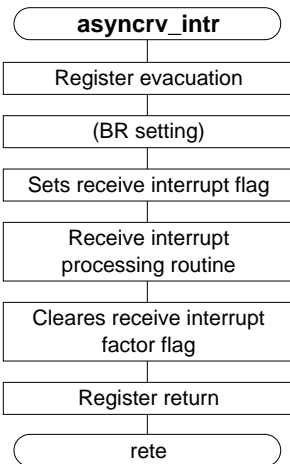

**Transmitting interrupt**

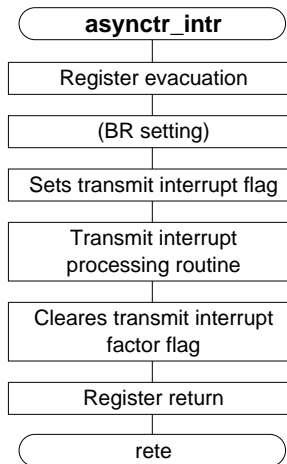

## Source List

**Asynchronous serial interface**

```

external    osc1toosc3,osc3toosc1
external    vdd_ngf
public      async_init,asynrcrv,asynctr
public      asynccerr_intr,asynrcrv_intr,asynctr_intr
public      receive_buffer,trans_buffer,receive_flag,trans_flag
public      error_flag,bps_data
;
asynccerr_vectorequ 000010h      ;async error interrupt vector offset
asynrcrv_vector    equ 000012h      ;async receive interrupt vector offset
asynctr_vector     equ 000014h      ;async trans interrupt vector offset
async              equ 003000h      ;program start address offset
br_io              equ 0ffh         ;base reg. address (set i/o area)
mode               equ 00ff02h      ;mode control reg.
ioc1               equ 00ff61h      ;plx i/o control reg.
p1d                equ 00ff63h      ;plx port data
smd                equ 00ff48h      ;serial interface mode set reg.
ser                equ 00ff49h      ;serial interface error and trigger reg
trxd               equ 00ff4ah      ;trans/recive data reg.
pt_mode0           equ 00ff30h      ;programmable timer mode set reg. 0
pt_mode2           equ 00ff32h      ;programmable timer mode set reg. 2
r1d1               equ 00ff34h      ;programmable timer 1 reload data
intr_pr0           equ 00ff20h      ;interrupt priority reg. 0
intr_pr1           equ 00ff21h      ;interrupt priority reg. 1
intr_en1           equ 00ff23h      ;interrupt enable reg. 1
intr_fac1          equ 00ff25h      ;interrupt factor reg. 1
;
    data
receive_buffer:db  [256]            ;async receive buffer
trans_buffer:   db  [256]            ;async trans buffer
error_flag:    db  [1]              ;async error flag
receive_flag:  db  [1]              ;trans complete flag
trans_flag:    db  [1]              ;receive complete flag
    code

```

**Vector address setting for serial interface interrupt**

```

intr_vectors:
;
    org    intr_vectors+asynccerr_vector
    dw    asynccerr_intr              ;async error interrupt
;
    org    intr_vectors+asynrcrv_vector
    dw    asynrcrv_intr              ;async receive interrupt
;
    org    intr_vectors+asynctr_vector
    dw    asynctr_intr              ;async trans interrupt
;

```

**(1) Initialization for asynchronous serial interface (8-bit mode)**

```

    org    intr_vectors+async
bps_data: db 0fh                    ;baud rate(osc3*1/1 9600bps:4.9152mhz)
;*****
;*
;*    async 8-bit mode initialize (p13 and 12 = hand shake:not use)
;*
;*****
;*** initialize routine
async_init:
;p17-14=programmable output,p13-12=hand shake,p11-10=async terminal
    ld    br,#br_io                  ;set br reg. address to 0ffxxh
    ld    [br:low p1d],#11110110b    ;sout="h" and no hand shake
    ld    [br:low ioc1],#11110110b
    ld    [br:low ser],#01110000b    ;rxen=dis.txen=dis.
;serial mode:even parity,clock=timer 1,async 8-bit mode and serial i/o select
    ld    [br:low smd],#01011111b    ;set serial interface mode
;pt:timer 8bit*2,pulse output=timer 1,pulse output=dis.,clock (timer0&1=fosc3)
    ld    [br:low pt_mode0],#00001011b
    ld    a,[loc bps_data]
    ld    [br:low r1d1],a            ;set reload data reg.
    ld    a,[br:low intr_pr0]        ;interrupt priority reg.
    and   a,#11001111b
    or    a,#00100000b
    ld    [br:low intr_pr0],a        ;set psif=/irq2
    ld    a,[br:low intr_pr1]        ;interrupt priority reg.

```

(1)

## 9 SERIAL INTERFACE 2 (ASYNCHRONOUS INTERFACE)

### Source List

```
and a,#11110011b
or a,#00001100b
ld [br:low intr_pr1],a
ld a,[low intr_en1]
and a,#01111000b ;ept1 interrupt dis.(baud rate control)
or a,#00000111b
ld [br:low intr_en1],a ;eserr esrec and estra intr. en
ld a,sc
and a,#00111111b
or a,#01000000b
ld sc,a ;il flag clear (en. /irq2 intr.)
ret
```

(1)

### (2) Receiving of asynchronous serial interface (8-bit mode)

```
*****
;*
;*      async 8-bit mode receive (p13 and 12 = hand shake:not use)      *
;*      *                                                                *
*****
*** control routine
asynrcrv:
ld br,#br_io ;set br reg. address to 0ffxxh
carl osc1toosc3 ;change osc1 to osc3 ***
ld a,[lod vdd_ngf] ;vdd ng flag
cp a,#0ffh
jrl z,asynrcrv03
;psc=1/1*fosc3(4.9152mhz),timer1=reload mode and reload data set to timer 1
ld [br:low pt_mode2],#00000110b
or [br:low pt_mode2],#00000001b ;timer 1 start (baud rate)
ld iy,#lod receive_buffer ;receive data buffer
ld b,#0 ;set receive counter (00h=256)
ld a,[br:low ser]
and a,#00000001b
ld [br:low ser],a ;rxen=0 (dis.) async reset
xor a,a
ld [lod receive_flag],a ;async receive interrupt flag clear
ld [lod error_flag],a ;async receive error flag clear
ld a,[br:low ser]
and a,#00000001b
or a,#00000100b
ld [br:low ser],a ;rxen=1 (en.)
;no hand shake
asynrcrv00:
ld a,[br:low ser]
and a,#00000101b
or a,#00001000b
ld [br:low ser],a ;rxtrg=set and error reset
;wait async receive interrupt
asynrcrv01:
ld a,[lod receive_flag] ;async receive interrupt flag
cp a,#0ffh
jrs z,asynrcrv02
;
ld a,[lod error_flag] ;async error interrupt flag
cp a,#00h
jrs z,asynrcrv01
;receive error occurs
;
;
;      async receive error processing
;
;
xor a,a
ld [lod error_flag],a ;clear error interrupt flag
jrs asynrcrv03
;
;receive no error
asynrcrv02:
xor a,a
ld [lod receive_flag],a ;clear async receive interrupt flag
ld a,[br:low trxd] ;receive data read
ld [iy],a ;set receive data buffer
inc iy ;receive buffer + 1
djr nz,asynrcrv00 ;until buffer end (256 bytes)
;
```

(2)

## Source List

```

asynrcv03:
  ld    a,[br:low ser]
  and   a,#00000001b
  ld    [br:low ser],a           ;rxen=0 (dis.) async reset
  and   [br:low pt_mode2],#00011100b ;timer 1 stop (baud rate)
  carl  osc3toosc1             ;change osc3 to osc1 ***
  ret

```

**(3) Transmitting of asynchronous serial interface (8-bit mode)**

```

;*****
;*
;*      async 8-bit mode trans (p13 and 12 = hand shake:not use)
;*
;*****
;*** control routine
asynctr:
  ld    br,#br_io              ;set br reg. address to 0ffxxh
  carl  osc1toosc3             ;change osc1 to osc3 ***
  ld    a,[lod vdd_ngf]       ;vdd ng flag
  cp    a,#0ffh
  jrl   z,asynctr02           ;vdd error
;psc=1/1*fosc3(4.9152mhz),timer1=reload mode and reload data set to timer 1
  ld    [br:low pt_mode2],#00000110b
  or    [br:low pt_mode2],#00000001b ;timer 1 start (baud rate)
  ld    iy,#lod trans_buffer   ;trans data buffer
  ld    b,#0                   ;set trans counter (00h=256)
  ld    a,[br:low ser]
  and   a,#00000100b
  ld    [br:low ser],a        ;txen=0 (dis.) async reset
  xor   a,a
  ld    [lod trans_flag],a    ;async trans interrupt flag clear
  ld    a,[br:low ser]
  and   a,#00000100b
  or    a,#00000001b
  ld    [br:low ser],a        ;txen=en.
;no hand shake
asynctr00:
  ld    a,[iy]                 ;load trans data buffer
  ld    [br:low trxd],a       ;set trans data
  inc   iy                     ;trans buffer + 1
  ld    a,[br:low ser]
  and   a,#00000101b
  or    a,#00000010b
  ld    [br:low ser],a        ;txtrg=set
;wait async trans interrupt
asynctr01:
  ld    a,[lod trans_flag]    ;async trans interrpu flag
  cp    a,#0ffh
  jrs   nz,asynctr01
;
  xor   a,a
  ld    [lod trans_flag],a    ;clear async trans interrupt flag
  djr   nz,asynctr00         ;until buffer end (256 bytes)
;
asynctr02:
  ld    a,[br:low ser]
  and   a,#00000100b
  ld    [br:low ser],a        ;txen=0 (dis.) async reset
  and   [br:low pt_mode2],#00011100b ;timer 1 stop (baud rate)
  carl  osc3toosc1             ;change osc3 to osc1 ***
  ret

```

**(2) Receiving error interrupt**

```

;*****
;*
;*      async 8-bit mode error interrupt processing routine
;*
;*****
asynccrr_intr:
  push  ale
;
  ld    br,#br_io              ;set br reg. address to 0ffxxh
;
  ld    a,[br:low ser]
  and   a,#01110101b

```

Source List

```

        ld    [br:low ser],a           ;receive error status reset
        and  a,#01110000b           ;ignore bits clear
        ld    [lod error_flag],a     ;set async error interrupt flag
;
;
;    async error interrupt processing routine
;
;
        and  [br:low intr_fac1],#00000100b ;clear fserr flag
        pop  ale
        rete

(2) Receiving interrupt
;*****
;*
;*    async 8-bit mode receive interrupt processing routine
;*
;*
;*****
asynrcrv_intr:
    push  ale
;
    ld    br,#br_io                 ;set br reg. address to 0ffxxh
;
    ld    a,#0ffh
    ld    [lod receive_flag],a     ;set async receive interrupt flag
;
;
;    async receive interrupt processing routine
;
;
        and  [br:low intr_fac1],#00000010b ;clear fsrec flag
        pop  ale
        rete

(3) Transmitting interrupt
;*****
;*
;*    async 8-bit mode trans interrupt processing routine
;*
;*
;*****
asynctr_intr:
    push  ale
;
    ld    br,#br_io                 ;set br reg. address to 0ffxxh
;
    ld    a,#0ffh
    ld    [lod trans_flag],a     ;set async trans interrupt flag
;
;
;    async trans interrupt processing routine
;
;
        and  [br:low intr_fac1],#00000001b ;clear fstra flag
        pop  ale
        rete
        end
    
```

# 10 CLOCK TIMER

## I/O Map

Address	Bit	Name	Function	1	0	SR	R/W	Comment			
00FF40	D7	–	–	–	–	–		"0" when being read			
	D6	FOUT2	FOUT frequency selection			0	R/W				
			FOUT2 FOUT1 FOUT0 Frequency								
			0 0 0 fosc1 / 1								
	D5	FOUT1	0 0 1 fosc1 / 2			0	R/W				
			0 1 0 fosc1 / 4								
			0 1 1 fosc1 / 8								
			1 0 0 fosc3 / 1								
	D4	FOUT0	1 0 1 fosc3 / 2			0	R/W				
		1 1 0 fosc3 / 4									
		1 1 1 fosc3 / 8									
	D3	FOUTON	FOUT output control	On	Off	0	R/W				
	D2	WDRST	Watchdog timer reset	Reset	No operation	–	W	Constantly "0" when			
	D1	TMRST	Clock timer reset	Reset	No operation	–	W	being read			
	D0	TMRUN	Clock timer Run/Stop control	Run	Stop	0	R/W				
00FF41	D7	TMD7	Clock timer data 1 Hz	High	Low	0	R				
	D6	TMD6	Clock timer data 2 Hz								
	D5	TMD5	Clock timer data 4 Hz								
	D4	TMD4	Clock timer data 8 Hz								
	D3	TMD3	Clock timer data 16 Hz								
	D2	TMD2	Clock timer data 32 Hz								
	D1	TMD1	Clock timer data 64 Hz								
	D0	TMD0	Clock timer data 128 Hz								
00FF20	D7	PK01	K00–K07 interrupt priority register	PK01 PK00	PSIF1 PSIF0	PSW1 PSW0	PTM1 PTM0	Priority level	0	R/W	
	D6	PK00									
	D5	PSIF1	Serial interface interrupt priority register	1 1	0 0	Level 3	Level 2	Level 1	0	R/W	
	D4	PSIF0									
	D3	PSW1	Stopwatch timer interrupt priority register	1 0	0 1	Level 2	Level 1	0	R/W		
	D2	PSW0									
	D1	PTM1	Clock timer interrupt priority register	0 0	Level 0	0	R/W				
D0	PTM0										
00FF22	D7	–	–	–	–	–		"0" when being read			
	D6	ESW100	Stopwatch timer 100 Hz interrupt enable register	Interrupt enable	Interrupt disable	0	R/W				
	D5	ESW10	Stopwatch timer 10 Hz interrupt enable register								
	D4	ESW1	Stopwatch timer 1 Hz interrupt enable register								
	D3	ETM32	Clock timer 32 Hz interrupt enable register								
	D2	ETM8	Clock timer 8 Hz interrupt enable register								
	D1	ETM2	Clock timer 2 Hz interrupt enable register								
	D0	ETM1	Clock timer 1 Hz interrupt enable register								
00FF24	D7	–	–						–	–	–
	D6	FSW100	Stopwatch timer 100 Hz interrupt factor flag	(R)	(R)	0	R/W				
	D5	FSW10	Stopwatch timer 10 Hz interrupt factor flag	Interrupt factor is generated	No interrupt factor is generated						
	D4	FSW1	Stopwatch timer 1 Hz interrupt factor flag								
	D3	FTM32	Clock timer 32 Hz interrupt factor flag								
	D2	FTM8	Clock timer 8 Hz interrupt factor flag								
	D1	FTM2	Clock timer 2 Hz interrupt factor flag	(W)	(W)						
D0	FTM1	Clock timer 1 Hz interrupt factor flag	Reset	No operation							



*Specifications*

**Control of clock timer**

**Vector address setting for clock timer interrupt**

**(1) rtm\_init: Initialization for clock timer**

Enables the respective 32 Hz, 8 Hz, 2 Hz and 1 Hz interrupts of the clock timer, clears the timer data and starts the clock timer. The interrupt level has been set at  $\overline{\text{IRQ1}}$ .

**(2) rtm32\_intr, rtm8\_intr, rtm2\_intr, rtm1\_intr: Clock timer interrupt processing**

**Flowchart**

**(1) Initialization for clock timer**

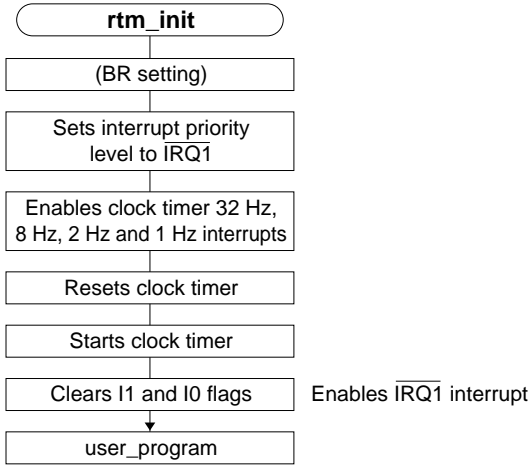

**(2) 32 Hz clock timer interrupt processing**

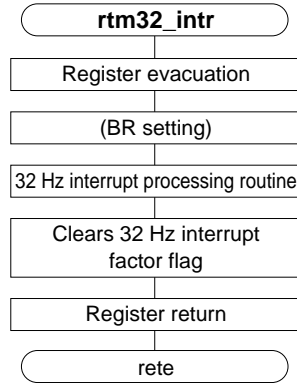

**(2) 8 Hz clock timer interrupt processing**

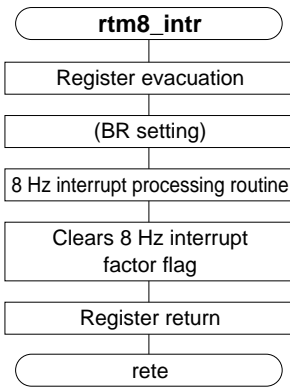

**(2) 2 Hz clock timer interrupt processing**

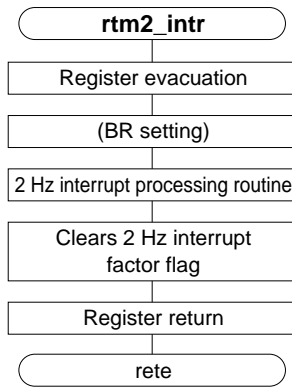

**(2) 1 Hz clock timer interrupt processing**

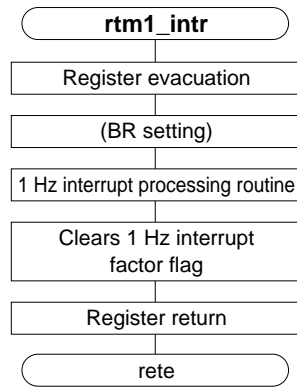

**Notes**

- (1) To reset the interrupt factor flag, write "1" into the corresponding flags alone, using the AND or LD instruction. When the OR logic operation instruction has been used, "1" is written for the interrupt factor flags that have been set to "1" within the same address and those flags are then clear.
- (2) The interrupt flags (I1 and I0) have not been reset in the interrupt processing routine of this program example, so an interrupt lower than  $\overline{\text{IRQ1}}$  level is disabled at the time of generation. When you wish to accept the next interrupt after an interrupt has been generated, re-setting of the interrupt flags or resetting the interrupt factor flag is necessary after due consideration for the nesting level.
- (3) When stopping the clock timer by writing "0" into the RUN/STOP control register for the clock timer, the clock timer count actually stops when it advances one count with the timing synchronized to the 256 Hz input clock. For this reason, when the clock timer stops, if the 32 Hz, 8 Hz, 2 Hz and 1 Hz interrupt factors are generated, the respective interrupt factor flags are set and if interrupt is enabled, an interrupt is generated. Thus, you should add an interrupt processing and interrupt factor flag resetting, if necessary.
- (4) In this program example for the clock timer, the vector address setting and program have been allocated from 003000H for the sake of convenience.

**Source List****Control of clock timer**

```

        external    user_program
        public      clock_init,clock32_intr,clock8_intr,clock2_intr,clock1_intr
;
clock32_vector equ 00001ch           ;clock32hz interrupt vector offset
clock8_vector  equ 00001eh           ;clock8hz interrupt vector offset
clock2_vector  equ 000020h           ;clock2hz interrupt vector offset
clock1_vector  equ 000022h           ;clock1hz interrupt vector offset
clock          equ 003000h           ;program start address offset
br_io          equ 0ffh              ;base reg. address (set i/o area)
clock_mode     equ 00ff40h           ;timer mode set reg.
clockd         equ 00ff41h           ;timer data
intr_pr0       equ 00ff20h           ;interrupt priority reg. 0
intr_en0       equ 00ff22h           ;interrupt enable reg. 0
intr_fac0      equ 00ff24h           ;interrupt factor flag reg.
;
        code

```

**Vector address setting for clock timer interrupt**

```

intr_vectors:
        org    intr_vectors+clock32_vector
        dw    clock32_intr           ;clock 32hz interrupt
;
        org    intr_vectors+clock8_vector
        dw    clock8_intr            ;clock 8hz interrupt
;
        org    intr_vectors+clock2_vector
        dw    clock2_intr            ;clock 2hz interrupt
;
        org    intr_vectors+clock1_vector
        dw    clock1_intr            ;clock 1hz interrupt
;

```

Source List

**(1) Initialization for clock timer**

```

org intr_vectors+clock
;*****
;*
;* clock timer initialize (32,8,2 and lhz interrupt enable)
;*
;*****
;*** initialize routine
clock_init:
    ld br,#br_io ;set br reg. address to 0ffxxh
    ld a,[br:low intr_pr0] ;interrupt priority reg.
    and a,#11111100b
    or a,#00000001b
    ld [br:low intr_pr0],a ;set ptm=/irq1
;etm32,etm8,etm2 and etm1 (en. /irq1) intr.
    or [br:low intr_en0],#00001111b
    or [br:low clock_mode],#00000010b ;clock timer counter reset
    or [br:low clock_mode],#00000001b ;clock timer start
    and sc,#00111111b ;il and i0 flag clear
;*****
;*** start clock timer interrupt
;
;
    jrl user_program
;
;

```

(1)

**(2) 32 Hz clock timer interrupt processing**

```

;*****
;*
;* clock timer 32hz interrupt processing routine
;*
;*****
clock32_intr:
    push ale
;
    ld br,#br_io ;set br reg. address to 0ffxxh
;
;
; clock timer 32hz processing routine
;
;
    and [br:low intr_fac0],#00001000b ;clear etm32 flag
    pop ale
    rete

```

**(2) 8 Hz clock timer interrupt processing**

```

;*****
;*
;* clock timer 8hz interrupt processing routine
;*
;*****
clock8_intr:
    push ale
;
    ld br,#br_io ;set br reg. address to 0ffxxh
;
;
; clock timer 8hz processing routine
;
;
    and [br:low intr_fac0],#00000100b ;clear etm8 flag
    pop ale
    rete

```

(2)

## Source List

**(2) 2 Hz clock timer interrupt processing**

```

;*****
;*
;*      clock timer 2hz interrupt processing routine
;*
;*****
clock2_intr:
    push    ale
;
;      ld    br,#br_io          ;set br reg. address to 0ffxxh
;
;
;      clock timer 2hz processing routine
;
;
;      and   [br:low intr_fac0],#00000010b    ;clear etm2 flag
    pop     ale
    rete

```

**(2) 1 Hz clock timer interrupt processing**

```

;*****
;*
;*      clock timer 1hz interrupt processing routine
;*
;*****
clock1_intr:
    push    ale
;
;      ld    br,#br_io          ;set br reg. address to 0ffxxh
;
;
;      clock timer 1hz processing routine
;
;
;      and   [br:low intr_fac0],#00000001b    ;clear etm1 flag
    pop     ale
    rete

    end

```

(2)

# 11 STOPWATCH TIMER

## I/O Map

Address	Bit	Name	Function	1	0	SR	R/W	Comment
00FF42	D7	–	–	–	–	–		Constantly "0" when being read
	D6	–	–	–	–	–		
	D5	–	–	–	–	–		
	D4	–	–	–	–	–		
	D3	–	–	–	–	–		
	D2	–	–	–	–	–		
	D1	SWRST	Stopwatch timer reset	Reset	No operation	–	W	
D0	SWRUN	Stopwatch timer Run/Stop control	Run	Stop	0	R/W		
00FF43	D7	SWD7	Stopwatch timer data					0 R
	D6	SWD6						
	D5	SWD5	BCD (1/10 sec)					
	D4	SWD4	-----					
	D3	SWD3	Stopwatch timer data					
	D2	SWD2	-----					
	D1	SWD1	BCD (1/100 sec)					
D0	SWD0	-----						
00FF20	D7	PK01	K00–K07 interrupt priority register	PK01 PK00 PSIF1 PSIF0	Priority level	0	R/W	
	D6	PK00						
	D5	PSIF1	Serial interface interrupt priority register	PSW1 PSW0 PTM1 PTM0	Level 3 Level 2 Level 1 Level 0	0	R/W	
	D4	PSIF0						
	D3	PSW1	Stopwatch timer interrupt priority register	1 1 1 0 0 1 0 0	Level 3 Level 2 Level 1 Level 0	0	R/W	
	D2	PSW0						
D1	PTM1	Clock timer interrupt priority register	0 0	Level 0	0	R/W		
D0	PTM0							
00FF22	D7	–	–	–	–	–		"0" when being read
	D6	ESW100	Stopwatch timer 100 Hz interrupt enable register	Interrupt enable	Interrupt disable	0	R/W	
	D5	ESW10	Stopwatch timer 10 Hz interrupt enable register					
	D4	ESW1	Stopwatch timer 1 Hz interrupt enable register					
	D3	ETM32	Clock timer 32 Hz interrupt enable register					
	D2	ETM8	Clock timer 8 Hz interrupt enable register					
	D1	ETM2	Clock timer 2 Hz interrupt enable register					
D0	ETM1	Clock timer 1 Hz interrupt enable register						
00FF24	D7	–	–	–	–	–		"0" when being read
	D6	FSW100	Stopwatch timer 100 Hz interrupt factor flag	(R)	(R)	0	R/W	
	D5	FSW10	Stopwatch timer 10 Hz interrupt factor flag	Interrupt factor is generated	No interrupt factor is generated			
	D4	FSW1	Stopwatch timer 1 Hz interrupt factor flag					
	D3	FTM32	Clock timer 32 Hz interrupt factor flag					
	D2	FTM8	Clock timer 8 Hz interrupt factor flag					
	D1	FTM2	Clock timer 2 Hz interrupt factor flag					
D0	FTM1	Clock timer 1 Hz interrupt factor flag	(W) Reset	(W) No operation				

*Specifications*

**Control of stopwatch timer**

**Vector address setting for stopwatch timer interrupt**

**(1) *sw\_init*: Initialization for stopwatch timer**

Enables the respective 100 Hz, 10 Hz and 1 Hz interrupts of the stopwatch timer, clears the timer data and starts the stopwatch timer. The interrupt level has been set at  $\overline{IRQ1}$ .

**(2) *sw100\_intr*, *sw10\_intr*, *sw1\_intr*: Stopwatch timer interrupt processing**

*Flowchart*

**(1) Initialization for stopwatch timer**

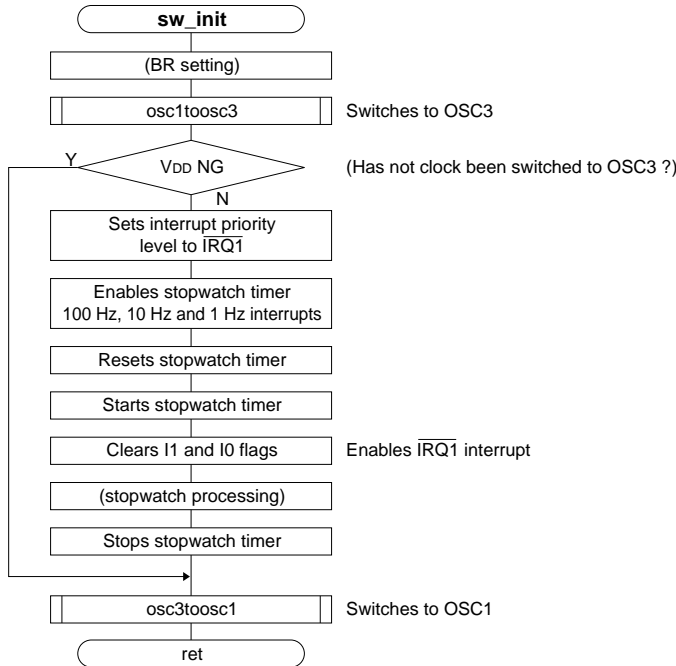

**(2) 100 Hz stopwatch timer interrupt processing**

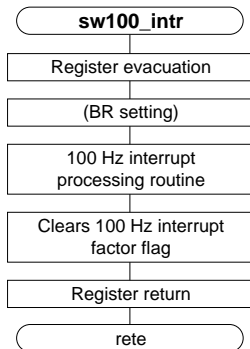

**(2) 10 Hz stopwatch timer interrupt processing**

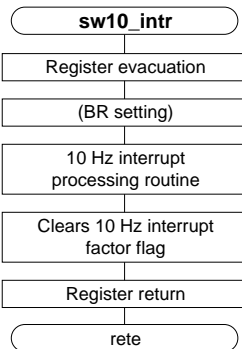

**(2) 1 Hz stopwatch timer interrupt processing**

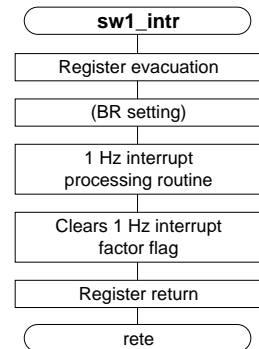

*Notes*

- (1) External routines are called for switching to OSC3 and OSC1. (external call: osc1toosc3, osc3toosc1)
- (2) Switching the operating mode when the supply voltage is lower than the VD1 setting may cause a malfunction. Hence, the example routine checks the supply voltage when switching to the normal mode (OSC3) and terminates as a supply voltage error remains unprocessed if the supply voltage is lower than the VD1 setting. For this determination, vdd\_ngf flag is used. (See "4 OSCILLATION CIRCUIT".)
- (3) When switching from OSC3 to OSC1 ( $VD1 = 2.2\text{ V} \rightarrow 1.3\text{ V}$ ), the program example does not perform special checking of the supply voltage of SVD if the supply voltage is already more than the VD1 setting.
- (4) To reset the interrupt factor flag, write "1" into the corresponding flags alone, using the AND or LD instruction. When the OR logic operation instruction has been used, "1" is written for the interrupt factor flags that have been set to "1" within the same address and those flags are then clear.
- (5) The interrupt flags (I1 and I0) have not been reset in the interrupt processing routine of this program example, so an interrupt lower than  $\overline{IRQ1}$  level is disabled at the time of generation. When you wish to accept the next interrupt after an interrupt has been generated, re-setting of the interrupt flags or resetting the interrupt factor flag is necessary after due consideration for the nesting level.
- (6) When stopping the stopwatch timer by writing "0" into the RUN/STOP control register for the stopwatch timer, the stopwatch timer count actually stops when it advances one count with the timing synchronized to the 256 Hz input clock.  
For this reason, when the stopwatch timer stops, if the 100 Hz, 10 Hz, and 1 Hz interrupt factors are generated, the respective interrupt factor flags are set and if interrupt is enabled, an interrupt is generated. Thus, you should add an interrupt processing and interrupt factor flag resetting, if necessary.
- (7) In this program example for the stopwatch timer, the vector address setting and program have been allocated from 003000H for the sake of convenience.

*Source List***Control of stopwatch timer**

```

        external    osc1toosc3,osc3toosc1
        external    vdd_ngf
        public      sw_init,sw100_intr,sw10_intr,sw1_intr
;
sw100_vector equ 000016h           ;sw100hz interrupt vector offset
sw10_vector  equ 000018h           ;sw10hz interrupt vector offset
sw1_vector   equ 00001ah           ;sw1hz interrupt vector offset
sw           equ 003000h           ;program start address offset
br_io       equ 0ffh              ;base reg. address (set i/o area)
sw_mode     equ 00ff42h           ;stopwatch mode set reg.
swd         equ 00ff43h           ;stopwatch data
intr_pr0    equ 00ff20h           ;interrupt priority reg. 0
intr_en0    equ 00ff22h           ;interrupt enable reg. 0
intr_fac0   equ 00ff24h           ;interrupt factor flag reg.
;
        code

```

## Source List

**Vector address setting for stopwatch timer interrupt**

```

intr_vectors:
    org    intr_vectors+sw100_vector
    dw     sw100_intr                ;sw 100hz interrupt
;
    org    intr_vectors+sw10_vector
    dw     sw10_intr                 ;sw 10hz interrupt
;
    org    intr_vectors+sw1_vector
    dw     sw1_intr                  ;sw 1hz interrupt
;

```

**(1) Initialization for stopwatch timer**

```

    org    intr_vectors+sw
;*****
;*
;*    stopwatch initialize (100,10 and 1hz interrupt enable)
;*
;*****
;*** initialize routine
sw_init:
    ld     br,#br_io                ;set br reg. address to 0ffxxh
    carl   osc1toosc3                ;change osc1 to osc3 ***
    ld     a,[lod vdd_ngf]           ;vdd ng flag
    cp     a,#0ffh
    jrl    z,sw_init00
;
    ld     a,[br:low intr_pr0]        ;interrupt priority reg.
    and    a,#111110011b
    or     a,#00000100b
    ld     [br:low intr_pr0],a        ;set sw=/irq1

;sw100,sw10 and sw1 (en. /irq1) intr.
    or     [br:low intr_en0],#01110000b
    or     [br:low sw_mode],#00000010b ;stopwatch counter reset
    or     [br:low sw_mode],#00000001b ;stopwatch start
    and    sc,#00111111b             ;il and i0 flag clear
;*****
;*** start stopwatch interrupt
;
;    (user program)
;
;*****
;*** end processing
    and    [br:low sw_mode],#11111110b ;stopwatch stop
sw_init00:
    carl   osc3toosc1                ;change osc3 to osc1 ***
    ret

```

(1)

**(2) 100 Hz stopwatch timer interrupt processing**

```

;*****
;*
;*    stopwatch 100hz interrupt processing routine
;*
;*****
sw100_intr:
    push   ale
;
    ld     br,#br_io                ;set br reg. address to 0ffxxh
;
;
;
;    stopwatch 100hz processing routine
;
;
;
    and    [br:low intr_fac0],#01000000b ;clear sw100 flag
    pop    ale
    rete

```

(2)



Source List

**(2) 10 Hz stopwatch timer interrupt processing**

```

;*****
;*
;*      stopwatch 10hz interrupt processing routine      *
;*
;*****
swl0_intr:
    push  ale
;
    ld    br,#br_io          ;set br reg. address to 0ffxxh
;
;
;      stopwatch 10hz processing routine
;
;
    and   [br:low intr_fac0],#00100000b    ;clear swl0 flag
    pop   ale
    rete

```

**(2) 1 Hz stopwatch timer interrupt processing**

```

;*****
;*
;*      stopwatch 1hz interrupt processing routine      *
;*
;*****
swl1_intr:
    push  ale
;
    ld    br,#br_io          ;set br reg. address to 0ffxxh
;
;
;      stopwatch 1hz processing routine
;
;
    and   [br:low intr_fac0],#00010000b    ;clear swl1 flag
    pop   ale
    rete
;
    end

```

(2)

# 12 PROGRAMMABLE TIMER

## I/O Map

Address	Bit	Name	Function	1	0	SR	R/W	Comment		
00FF30	D7	–	–	–	–	–		Constantry "0" when being read		
	D6	–	–	–	–	–				
	D5	–	–	–	–	–				
	D4	MODE16	8/16-bit mode selection		16-bit x 1	8-bit x 2	0	R/W		
	D3	CHSEL	TOUT output channel selection		Timer 1	Timer 0	0	R/W		
	D2	PTOUT	TOUT output control		On	Off	0	R/W		
	D1	CKSEL1	Prescaler 1 source clock selection		fosc3	fosc1	0	R/W		
	D0	CKSEL0	Prescaler 0 source clock selection		fosc3	fosc1	0	R/W		
00FF31	D7	EVCNT	Timer 0 counter mode selection		Event counter	Timer	0	R/W		
	D6	FCSEL	Timer 0 function selection	In timer mode	Pulse width measurement	Normal mode	0	R/W		
				In event counter mode	With noise rejector	Without noise rejector				
	D5	PLPOL	Timer 0 pulse polarity selection	Down count timing in event counter mode	Rising edge of K10 input	Falling edge of K10 input	0	R/W		
				In pulse width measurement mode	High level measurement for K10 input	Low level measurement for K10 input				
	D4	PSC01	Timer 0 prescaler dividing ratio selection					0	R/W	
			PSC01	PSC00	Prescaler dividing ratio					
	D3	PSC00	1	1	Source clock / 64			0	R/W	
			1	0	Source clock / 16					
			0	1	Source clock / 4					
0			0	Source clock / 1						
D2	CONT0	Timer 0 continuous/one-shot mode selection		Continuous	One-shot	0	R/W			
D1	PSET0	Timer 0 preset		Preset	No operation	–	W	"0" when being read		
D0	PRUN0	Timer 0 Run/Stop control		Run	Stop	0	R/W			
00FF32	D7	–	–	–	–	–		Constantry "0" when being read		
	D6	–	–	–	–	–				
	D5	–	–	–	–	–				
	D4	PSC11	Timer 1 prescaler dividing ratio selection					0	R/W	
			PSC11	PSC10	Prescaler dividing ratio					
	D3	PSC10	1	1	Source clock / 64			0	R/W	
			1	0	Source clock / 16					
			0	1	Source clock / 4					
0			0	Source clock / 1						
D2	CONT1	Timer 1 continuous/one-shot mode selection		Continuous	One-shot	0	R/W			
D1	PSET1	Timer 1 preset		Preset	No operation	–	W	"0" when being read		
D0	PRUN1	Timer 1 Run/Stop control		Run	Stop	0	R/W			

## 12 PROGRAMMABLE TIMER

### I/O Map

Address	Bit	Name	Function	1	0	SR	R/W	Comment
00FF33	D7	RLD07	Timer 0 reload data D7 (MSB)	High	Low	1	R/W	
	D6	RLD06	Timer 0 reload data D6					
	D5	RLD05	Timer 0 reload data D5					
	D4	RLD04	Timer 0 reload data D4					
	D3	RLD03	Timer 0 reload data D3					
	D2	RLD02	Timer 0 reload data D2					
	D1	RLD01	Timer 0 reload data D1					
	D0	RLD00	Timer 0 reload data D0 (LSB)					
00FF34	D7	RLD17	Timer 1 reload data D7 (MSB)	High	Low	1	R/W	
	D6	RLD16	Timer 1 reload data D6					
	D5	RLD15	Timer 1 reload data D5					
	D4	RLD14	Timer 1 reload data D4					
	D3	RLD13	Timer 1 reload data D3					
	D2	RLD12	Timer 1 reload data D2					
	D1	RLD11	Timer 1 reload data D1					
	D0	RLD10	Timer 1 reload data D0 (LSB)					
00FF35	D7	PTD07	Timer 0 counter data D7 (MSB)	High	Low	1	R	
	D6	PTD06	Timer 0 counter data D6					
	D5	PTD05	Timer 0 counter data D5					
	D4	PTD04	Timer 0 counter data D4					
	D3	PTD03	Timer 0 counter data D3					
	D2	PTD02	Timer 0 counter data D2					
	D1	PTD01	Timer 0 counter data D1					
	D0	PTD00	Timer 0 counter data D0 (LSB)					
00FF36	D7	PTD17	Timer 1 counter data D7 (MSB)	High	Low	1	R	
	D6	PTD16	Timer 1 counter data D6					
	D5	PTD15	Timer 1 counter data D5					
	D4	PTD14	Timer 1 counter data D4					
	D3	PTD13	Timer 1 counter data D3					
	D2	PTD12	Timer 1 counter data D2					
	D1	PTD11	Timer 1 counter data D1					
	D0	PTD10	Timer 1 counter data D0 (LSB)					

## I/O Map

Address	Bit	Name	Function	1	0	SR	R/W	Comment	
00FF21	D7	—	—	—	—	—	—	Constantly "0" when being read	
	D6	—	—	—	—	—	—		
	D5	—	—	—	—	—	—		
	D4	—	—	—	—	—	—		
	D3	PPT1	Programmable timer interrupt priority register	PPT1	PPT0	Priority level	0	R/W	
	D2	PPT0		PK11	PK10	Level 3			
D1	PK11	K10 and K11 interrupt priority register	1	0	Level 2	0	R/W		
D0	PK10		0	1	Level 1				
			0	0	Level 0				
00FF23	D7	EPT1	Programmable timer 1 interrupt enable register	Interrupt enable	Interrupt disable	0	R/W		
	D6	EPT0	Programmable timer 0 interrupt enable register						
	D5	EK1	K10 and K11 interrupt enable register						
	D4	EK0H	K04–K07 interrupt enable register						
	D3	EK0L	K00–K03 interrupt enable register						
	D2	ESERR	Serial I/F (error) interrupt enable register						
	D1	ESREC	Serial I/F (receiving) interrupt enable register						
D0	ESTRA	Serial I/F (transmitting) interrupt enable register							
00FF25	D7	FPT1	Programmable timer 1 interrupt factor flag	(R)	(R)	0	R/W		
	D6	FPT0	Programmable timer 0 interrupt factor flag	Interrupt factor is generated	No interrupt factor is generated				
	D5	FK1	K10 and K11 interrupt factor flag	Reset	(W)				No operation
	D4	FK0H	K04–K07 interrupt factor flag						
	D3	FK0L	K00–K03 interrupt factor flag						
	D2	FSERR	Serial I/F (error) interrupt factor flag						
	D1	FSREC	Serial I/F (receiving) interrupt factor flag						
	D0	FSTRA	Serial I/F (transmitting) interrupt factor flag						

## Specifications

## Control of programmable timer

**Vector address setting for programmable timer interrupt****(1) timer2ch\_init, pt1\_intr, pt0\_intr: Initialization and interrupt processing for 8-bit reload timer (two channels)**

This is an example of using the programmable timer as an 8-bit x 2 system and performs the following settings:

- Count mode 8-bit x 2
- Pulse output channel Timer 0
- Pulse external (TOUT) output OFF

(Invalid)

## &lt;Timer 0&gt;

- Timer mode Programmable timer (reload mode)
- Count clock  $f_{OSC3} \times 1/16$
- Reload data 200 (= 800  $\mu$ sec, when  $f_{OSC3}$  is 4 MHz)

## &lt;Timer 1&gt;

- Timer mode Programmable timer (reload mode)
- Count clock  $f_{OSC3} \times 1/64$
- Reload data 250 (= 1 msec, when  $f_{OSC3}$  is 4 MHz)

After setting the above, it enables the timer 1 and timer 0 interrupts, and starts each timer. The interrupt level has been set at  $\overline{IRQ3}$  and the respective interrupts are generated in the cycles according to the reload data.

Specifications

**Vector address setting for programmable timer interrupt**

**(2) timer1ch\_init, pt0\_intr: Initialization and interrupt processing for 16-bit one-shot timer (one channel)**

This is an example of using the programmable timer as a 16-bit x 1 system one-shot timer and performs the following settings:

- Count mode 16-bit x 1
  - Pulse output channel Timer 0
  - Pulse external (TOUT) output OFF
- (Invalid)

<Timer 0>

- Timer mode Programmable timer (one-shot mode)
- Count clock  $f_{OSC3} \times 1/4$
- Reload data 33,200 (= 33.2 msec, when  $f_{OSC3}$  is 4 MHz)

<Timer 1>

Cannot be used

After setting the above, it enables the timer 1 interrupt, and starts the timer.

The interrupt level has been set at  $\overline{IRQ3}$  and an interrupt is generated 33.2 msec after starting.

**Vector address setting for programmable timer interrupt**

**(3) evcnt\_init, pt1\_intr, evcnt\_intr: Initialization and interrupt processing for 8-bit event counter**

This is an example of using the programmable timer as an 8-bit event counter and 8-bit reload timer, and performs the following settings:

- Count mode 8-bit x 2
  - Pulse output channel Timer 0
  - Pulse external (TOUT) output OFF
- (Invalid)

<Timer 0>

- Timer mode Event counter (reload mode)
- Input clock K10 with noise rejector
- Count timing Falling edge
- Reload data 0FFH (Event counter initial value)

<Timer 1>

- Timer mode Programmable timer (reload mode)
- Count clock  $f_{OSC3} \times 1/64$
- Reload data 250 (= 4 msec, when  $f_{OSC3}$  is 4 MHz)

After setting the above, it enables the the event counter and timer 1 interrupts, and starts each timer.

The interrupt level has been set at  $\overline{IRQ3}$  and an interrupt is generated by the overflow of the event counter or timer 1.

Timer 1 is programmed to generate an interrupt in 4 msec cycles. This example reads the event counter data in the interrupt processing routine and calculates the difference between it and previous count value. This difference is made to the number of clocks that had been input in the 4 msec period.

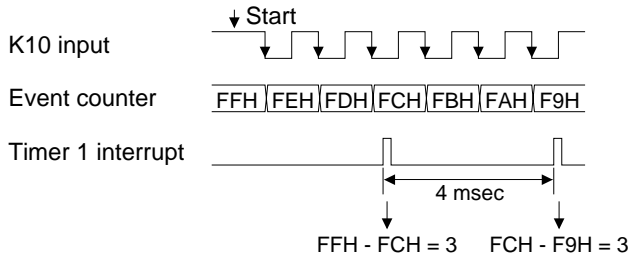

Fig. 12.1 Event counter processing

## Specifications

**Vector address setting for programmable timer interrupt****(4) *measure\_init, measure\_intr, k1x\_intr*: Initialization and interrupt processing for 16-bit pulse width measurement timer**

This is an example of using the programmable timer as a 16-bit pulse width measurement timer and performs the following settings:

- Count mode 16-bit x 1
  - Pulse output channel Timer 0
  - Pulse external (TOUT) output OFF
- ] (Invalid)

**<Timer 0>**

- Timer mode Pulse width measurement timer (reload mode)
- Measurement period During LOW input
- Count clock  $f_{OSC3} \times 1/1$
- Reload data 0FFFFH (Pulse width measurement timer initial value)

**<Timer 1>** Cannot be used

After setting the above, it enables the timer 1 and K10 input interrupts, and starts the timer. The interrupt level has been set at  $\overline{IRQ3}$  and an interrupt is generated by the overflow of the timer or K10 input.

Since the fall (count start) and rise (count completion) timings of the K10 input cannot be evaluated by programmable timer control only, a K10 input interrupt is used. Furthermore, in order to be able to generate an interrupt at both falling and rising timings, input interrupt timing is reversed by each interrupt generation in the K1x interrupt processing routine.

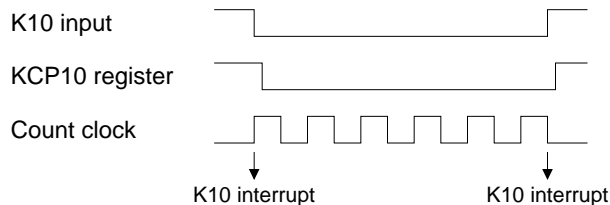

Fig. 12.2 Timing of K10 input interrupt generation

**Vector address setting for programmable timer interrupt****(5) *pulsout\_init*: 16-bit reload timer pulse output**

Outputs TOUT signal from the R27 terminal using the programmable timer as 16-bit reload timer.

- Count mode 16-bit x 1
  - Pulse output channel Timer 0
  - Pulse external (TOUT) output ON
- ] (Valid)

**<Timer 0>**

- Timer mode Programmable timer (reload mode)
- Count clock  $f_{OSC3} \times 1/4$
- Reload data 33,200 (= 33.2 msec, when  $f_{OSC3}$  is 4 MHz)

**<Timer 1>** Cannot be used

According to the above setting, the clock cycle of the TOUT signal is set at 66.4 msec (approximately 15 Hz).

Flowchart

(1) Initialization for 8-bit reload timer (two channels)

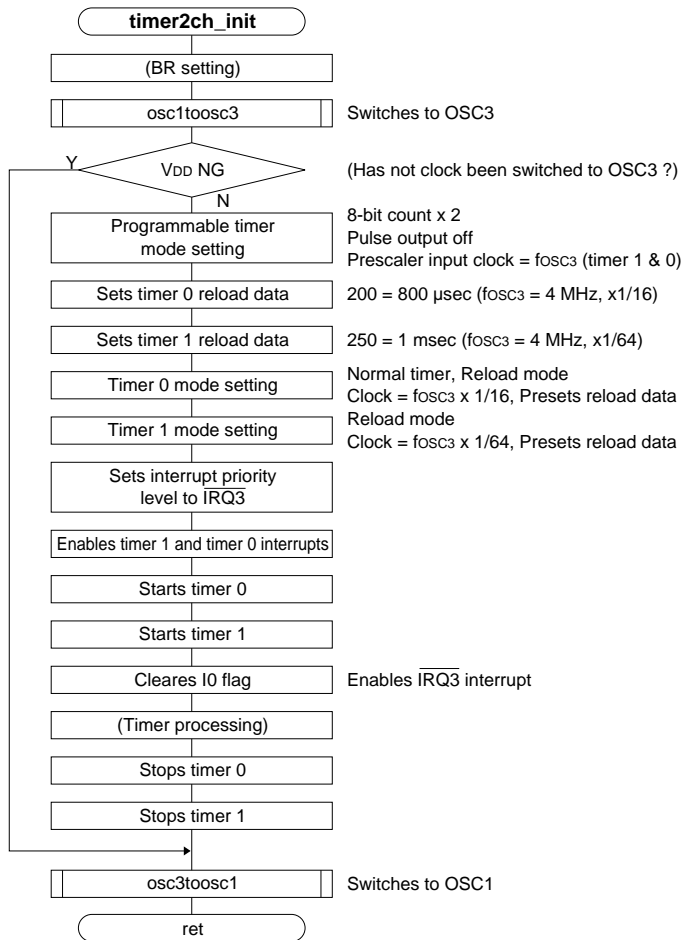

(1) Interrupt processing for 8-bit reload timer (two channels)

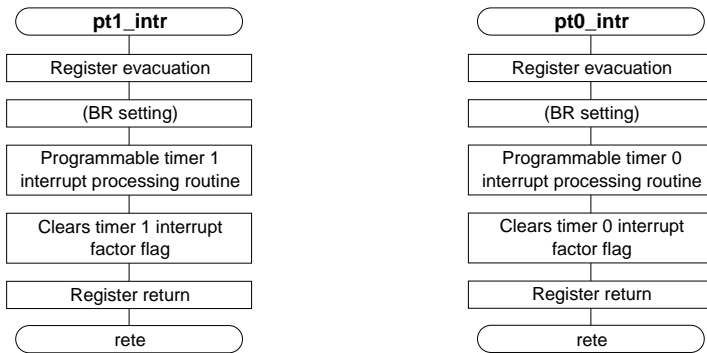

Flowchart

(2) Initialization for 16-bit one-shot timer (one channel)

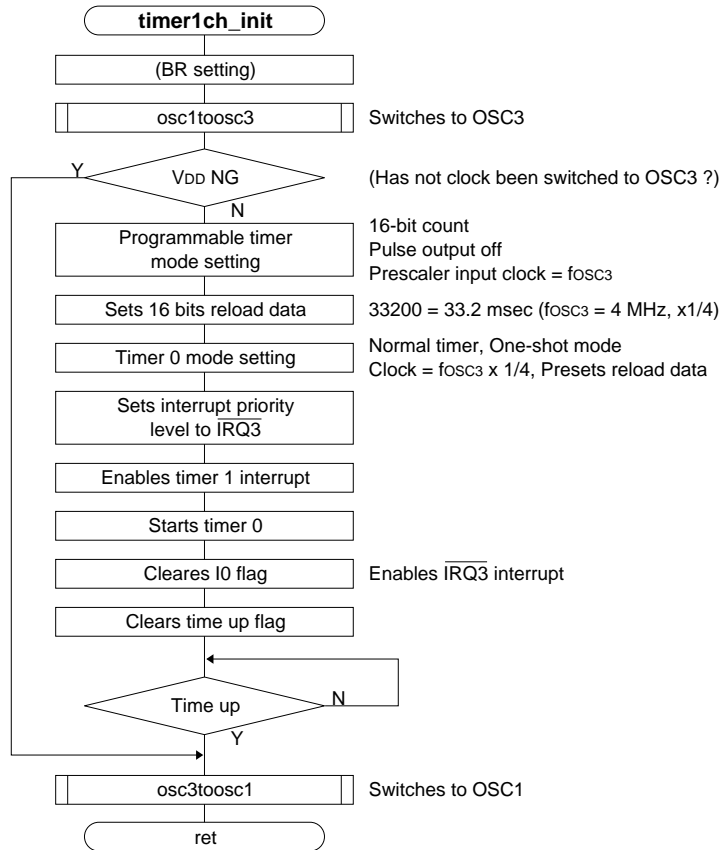

(2) Interrupt processing for 16-bit one-shot timer (one channel)

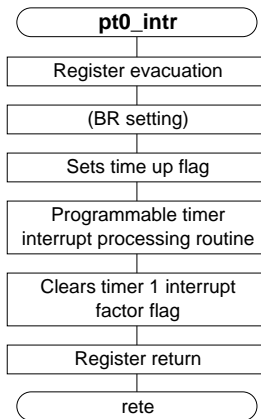



Flowchart

(3) Initialization for 8-bit event counter

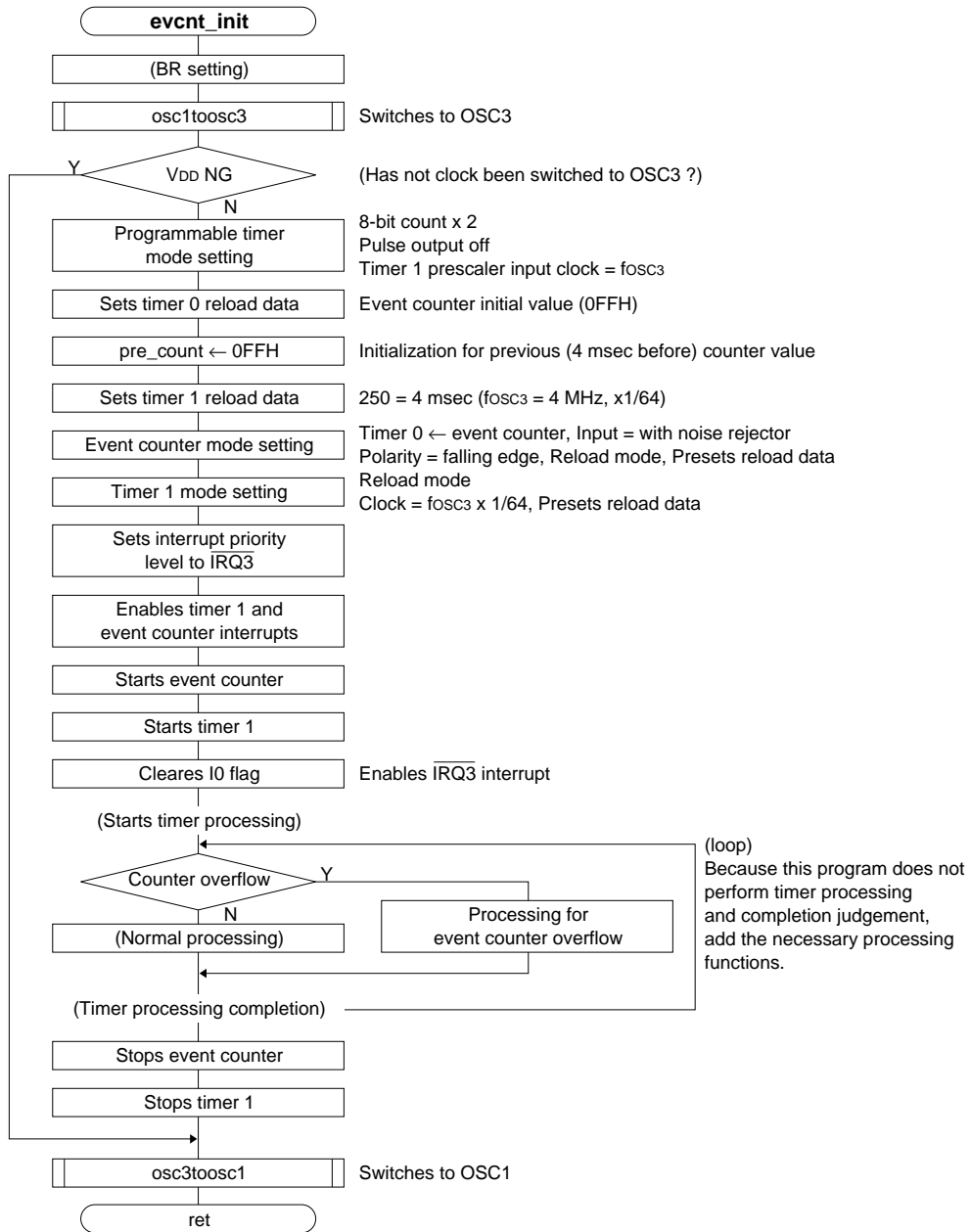

## Flowchart

## (3) Interrupt processing for 8-bit event counter

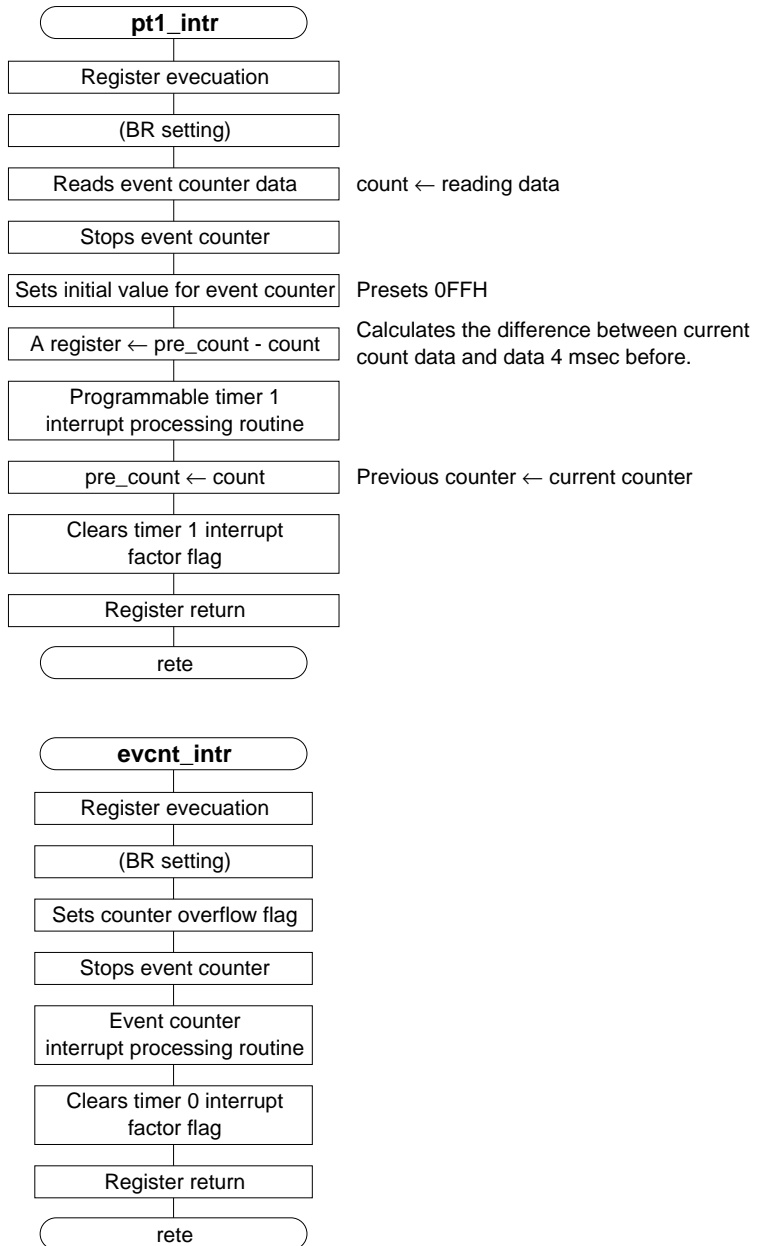

Flowchart

(4) Initialization for 16-bit pulse width measurement timer

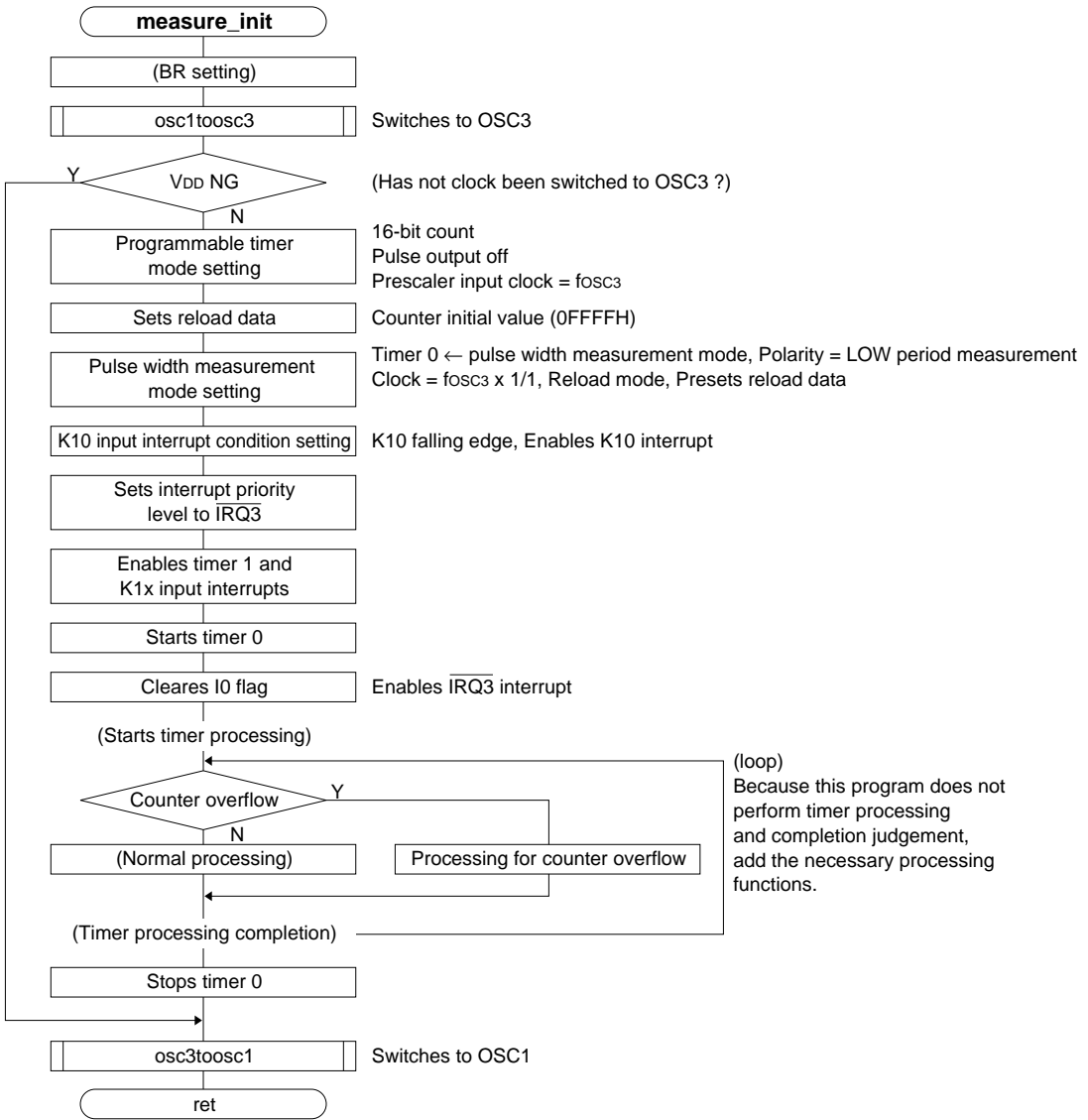

## Flowchart

## (4) Interrupt processing for 16-bit pulse width measurement timer

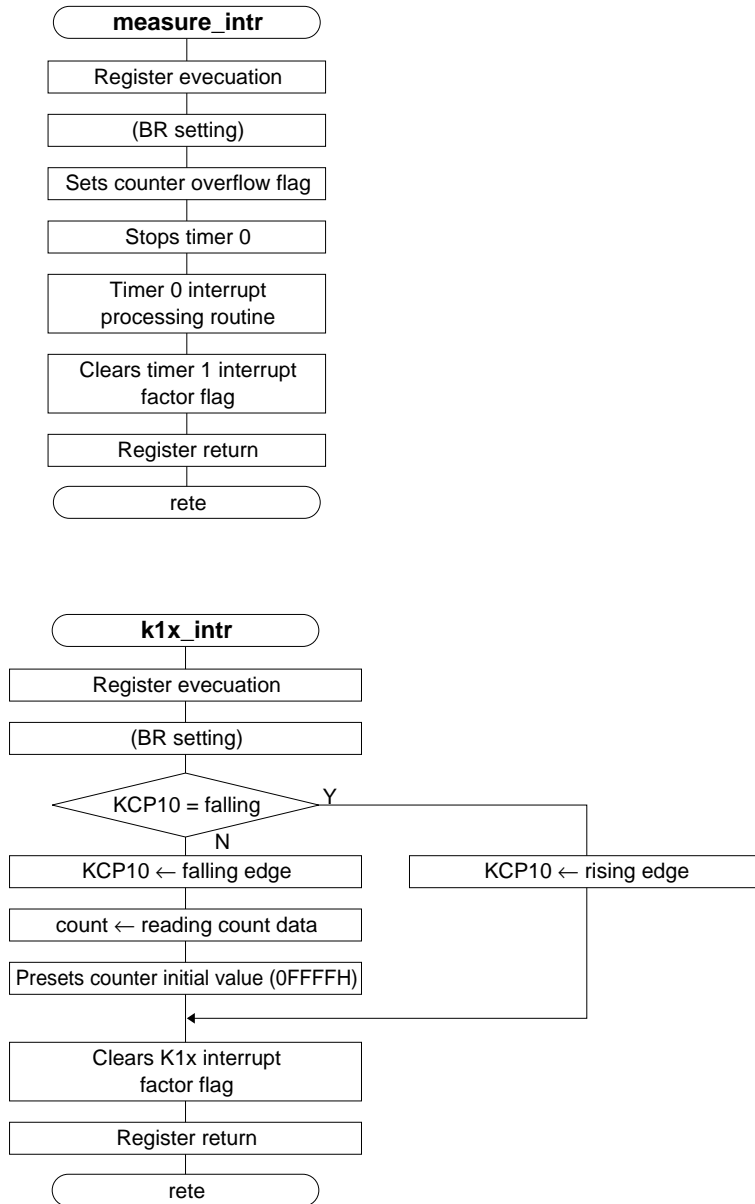

Flowchart

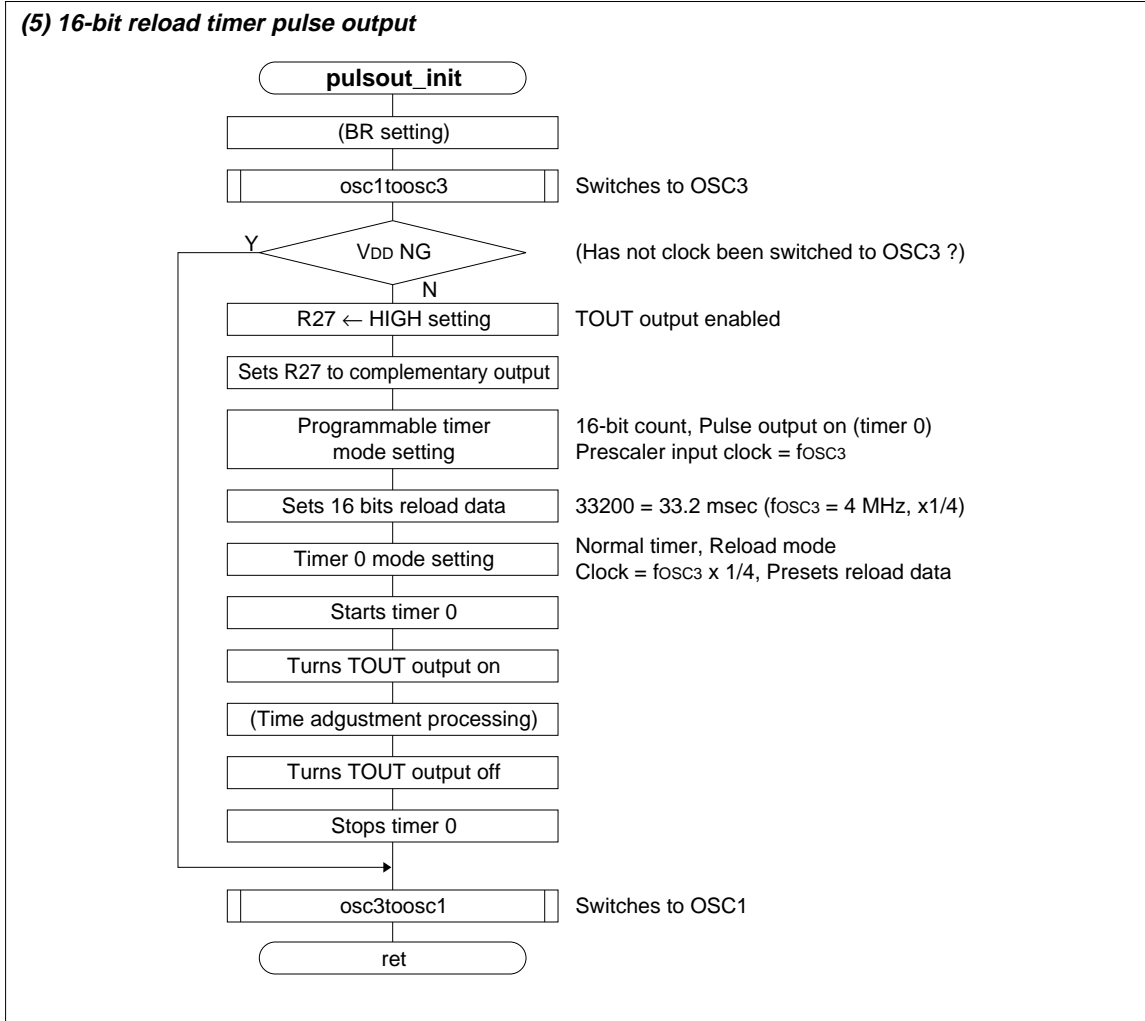

Notes

- (1) External routines are called for switching to OSC3 and OSC1. (external call: osc1toosc3, osc3toosc1)
- (2) Switching the operating mode when the supply voltage is lower than the VD1 setting may cause a malfunction. Hence, the example routine checks the supply voltage when switching to the normal mode (OSC3) and terminates as a supply voltage error remains unprocessed if the supply voltage is lower than the VD1 setting. For this determination, vdd\_ngf flag is used. (See "4 OSCILLATION CIRCUIT".)
- (3) When switching from OSC3 to OSC1 (VD1 = 2.2 V → 1.3 V), the program example does not perform special checking of the supply voltage of SVD if the supply voltage is already more than the VD1 setting.
- (4) To reset the interrupt factor flag, write "1" into the corresponding flags alone, using the AND or LD instruction. When the OR logic operation instruction has been used, "1" is written for the interrupt factor flags that have been set to "1" within the same address and those flags are then clear.
- (5) The interrupt flags (I1 and I0) have not been reset in the interrupt processing routine of this program example, so an interrupt lower than IRQ3 level is disabled at the time of generation. When you wish to accept the next interrupt after an interrupt has been generated, re-setting of the interrupt flags or resetting the interrupt factor flag is necessary after due consideration for the nesting level.

*Notes*

- (6) The R27 terminal is the common terminal for the normal DC output port and the TOUT output. When TOUT is being output, set R27 register to "1" and control the signal ON/OFF using the TOUT register.
- (7) When the pulse output control is set to off ("0"), the setting of the pulse output channel selection becomes invalid.
- (8) When programmable timer 1 is selected as the clock source for the serial interface, pay attention to the setting value for timer 1, the mode selection for timer 1 and the interrupt setting. Be advised that in this case, it is impossible to use it as a 16-bit timer coupling both timer 0 and timer 1.
- (9) When coupling programmable timers 0 and 1 for use as a 16-bit timer, the setting of timer 0 becomes valid for timer operation and the setting of timer 1 becomes invalid. However, since an interrupt is generated by the underflow of timer 1, set the interrupt related routine with timer 1.
- (10) When stopping the programmable timer by writing "0" into the RUN/STOP control register for the programmable timer 0 and 1, the programmable timer count actually stops when it advances one count with the timing synchronized to the input clock selected with the prescaler dividing clock. For this reason, when the programmable timer stops, if the respective interrupt factors are generated, the respective interrupt factor flags are set and if interrupt is enabled, an interrupt is generated. Thus, you should add an interrupt processing and interrupt factor flag resetting, if necessary.
- (11) A noise reject circuit is not included in the input port (K port). For this reason, when the programmable timer is used for event counter in the program example (3) or for pulse width measurement in the example (4), the following operation will occur if there is chattering in the K10 input, so, input waveform shaping or adding external noise reject processing with an external circuit and software is necessary. In case of the event counter in the program example (3), if there is chattering in the K10 input, the chattering may be counted. In the case of pulse width measurement in the program example (4), if there is chattering in the K10 input, successive interrupts may be generated in the measurement start trigger timing of the rising or falling K10 input.
- (12) When a down-counter underflow occurs, the one-shot timer mode sets the reload register value to the counter data register, to stop the count. For this reason, when you want to continue the count at the same count number, you should restart to timer. If you want to newly set a different count number, set the new value in the reload register, then set it to the count data register, and then start the timer.
- (13) In the examples of programmable timer control programs which use an interrupt, the vector address setting and program have been allocated from 003000H for the sake of convenience. For an example which does not use an interrupt, a specific address has not been allocated as in the examples in other chapters.

## Source List

**Control of programmable timer 1**

```

        external   osc1toosc3,osc3toosc1
        external   vdd_ngf
        public     timer2ch_init,pt1_intr,pt0_intr
;
pt1_vector   equ   000006h           ;timer 0 interrupt vector offset
pt0_vector   equ   000008h           ;timer 1 interrupt vector offset
pt           equ   003000h           ;program start address offset
br_io        equ   0ffh              ;base reg. address (set i/o area)
pt_mode0     equ   00ff30h           ;programmable timer mode set reg. 0
pt_mode1     equ   00ff31h           ;programmable timer mode set reg. 1
pt_mode2     equ   00ff32h           ;programmable timer mode set reg. 2
rld0         equ   00ff33h           ;programmable timer 0 reload data
rld1         equ   00ff34h           ;programmable timer 1 reload data
;
intr_pr1     equ   00ff21h           ;interrupt priority reg. 1
intr_en1     equ   00ff23h           ;interrupt enable reg. 1
intr_fac1    equ   00ff25h           ;interrupt factor flag reg. 1
;
        code

```

**Vector address setting for programmable timer interrupt**

```

intr_vectors:
        org     intr_vectors+pt1_vector
        dw     pt1_intr               ;programmable timer 1 interrupt
;
        org     intr_vectors+pt0_vector
        dw     pt0_intr               ;programmable timer 0 interrupt
;

```

**(1) Initialization for 8-bit reload timer (two systems)**

```

        org     intr_vectors+pt
timerdata8_0: db   200                ;timer 0 reload data (800us at 4mhz/16)
timerdata8_1: db   250                ;timer 1 reload data ( 1ms at 4mhz/64)
;
;*****
;*
;*      8-bit * 2-channel reload timer
;*
;*****
;*** initialize routine
timer2ch_init:
        ld     br,#br_io              ;set br reg. address to 0ffxxh
        carl   osc1toosc3             ;change osc1 to osc3 ***
        ld     a,[lod vdd_ngf]        ;vdd ng flag
        cp     a,#0ffh
        jrl   z,timer2ch_init00
;
;mode16=8bit*2,chs1=timer0,ptout=off,cksel1&0=fosc3
        ld     [br:low pt_mode0],#00000011b
        ld     a,[loc timerdata8_0]
        ld     [br:low rld0],a        ;set reload data (timer 0)
        ld     a,[loc timerdata8_1]
        ld     [br:low rld1],a        ;set reload data (timer 1)
;pt0:evcnt=timer,fcsel=normal timer,plpol=don't care,psc=fosc3/16,rldm0=reload
;pset0=preset
        ld     [br:low pt_mode1],#00010110b
;pt1:psc=fosc3/64,rldm1=reload,pset1=preset
        ld     [br:low pt_mode2],#00011110b
        or     [br:low intr_pr1],#00001100b   ;set pt=/irq3
        or     [br:low intr_en1],#11000000b   ;ept1&0 intr. en.
        or     [br:low pt_mode1],#00000001b   ;start timer 0
        or     [br:low pt_mode2],#00000001b   ;start timer 1
        ld     a,sc
        and    a,#00111111b
        or     a,#10000000b
        ld     sc,a                   ;i0 flag clear (en. /irq3 intr.)

```

*Source List*

```

;*****
;*** start programmable timer 0 & 1 interrupt
;   (user program)
;
;*****
;*** end processing
      and   [br:low pt_mode1],#11111110b      ;stop timer 0
      and   [br:low pt_mode2],#11111110b      ;stop timer 1
timer2ch_init00:
      carl  osc3toosc1                          ;change osc3 to osc1 ***
      ret

```

**(1) Interrupt processing for 8-bit reload timer (two systems)**

```

;*****
;*
;*   programmable timer 1 interrupt processing routine (reload mode)
;*
;*
;*****
pt1_intr:
      push  ale
;
      ld    br,#br_io                          ;set br reg. address to 0ffxxh
;
;   programmable timer 1 processing
;
;
      and   [br:low intr_fac1],#10000000b      ;clear fpt1 interrupt flag
      pop   ale
      rete
;*****
;*
;*   programmable timer 0 interrupt processing routine (reload mode)
;*
;*
;*****
pt0_intr:
      push  ale
;
      ld    br,#br_io                          ;set br reg. address to 0ffxxh
;
;   programmable timer 0 processing
;
;
      and   [br:low intr_fac1],#01000000b      ;clear fpt0 interrupt flag
      pop   ale
      rete
      end

```



## Source List

**Control of programmable timer 2**

```

        external    osc1toosc3,osc3toosc1
        external    vdd_ngf
        public      timer1ch_init,pt0_intr
        public      timeup
;
pt1_vector    equ    000006h                ;timer 1 interrupt vector offset
pt            equ    003000h                ;program start address offset
br_io        equ    0ffh                    ;base reg. address (set i/o area)
pt_mode0     equ    00ff30h                ;programmable timer mode set reg. 0
pt_model     equ    00ff31h                ;programmable timer mode set reg. 1
rld0         equ    00ff33h                ;programmable timer 0 reload data
rld1         equ    00ff34h                ;programmable timer 1 reload data
;
intr_pr1     equ    00ff21h                ;interrupt priority reg. 1
intr_en1     equ    00ff23h                ;interrupt enable reg. 1
intr_fac1    equ    00ff25h                ;interrupt factor flag reg. 1
;
        data
timeup:      db    [1]                      ;timeup flag
;
        code

```

**Vector address setting for programmable timer interrupt**

```

intr_vectors:
        org    intr_vectors+pt1_vector
        dw    pt1_intr                      ;programmable timer 0 interrupt
;

```

**(2) Initialization for 16-bit one-shot timer (one system)**

```

        org    intr_vectors+pt
timerdata16: dw    33200                    ;timer16 reload data (33.2ms at 4mhz/4)
;*****
;*
;*    16-bit * 1-channel one shot timer
;*
;*****
;*** initialize routine
timer1ch_init:
        ld    br,#br_io                    ;set br reg. address to 0ffxxh
        carl  osc1toosc3                    ;change osc1 to osc3 ***
        ld    a,[lod vdd_ngf]               ;vdd ng flag
        cp    a,#0ffh
        jrl   z,timer1ch_init00
;
;model16=16-bit,chsels=timer0,ptout=off,cksell=dont't care,ckse0=fosc3
        ld    [br:low pt_mode0],#00010001b
        ld    ba,[loc timerdata16]         ;set 16-bit reload data (timer 0 & 1)
        ld    [lod rld0],ba
;pt0:evcnt=timer,fcsel=normal timer,plpol=don't care,psc=fosc3/4,rldm0=oneshot
;pset0=preset
        ld    [br:low pt_model],#00001010b
        or    [br:low intr_pr1],#00001100b ;set pt=/irq3
        or    [br:low intr_en1],#10000000b ;ept1 intr. en.
        or    [br:low pt_model],#00000001b ;start timer 0
        ld    a,sc
        and   a,#00111111b
        or    a,#10000000b
        ld    sc,a                          ;i0 flag clear (en. /irq3 intr.)
        xor   a,a
        ld    [lod timeup],a
;*****
;*** start programmable timer 0 (16-bit) interrupt
timer1ch_init01:
        ld    a,[lod timeup]
        cp    a,#0ffh
        jrs   nz,timer1ch_init01
;*****
;*** end processing
timer1ch_init00:
        carl  osc3toosc1                    ;change osc3 to osc1 ***
        ret

```

*Source List***(2) Interrupt processing for 16-bit one-shot timer (one system)**

```

;*****
;*
;*   programmable timer 1 interrupt processing routine (one-shot mode)
;*
;*****
pt0_intr:
    push    ale
;
    ld     br,#br_io           ;set br reg. address to 0ffxxh
    ld     a,#0ffh
    ld     [lod timeup],a     ;timeup flag set
;
;
;   programmable timer 0 processing
;
;
    and   [br:low intr_fac1],#10000000b ;clear fpt1 interrupt flag
    pop   ale
    retd
end

```

## Source List

**Control of programmable timer 3**

```

        external    osc1toosc3,osc3toosc1
        external    vdd_ngf
        public      evcnt_init,evcnt_intr,pt1_intr
        public      pre_count,count,ovf_flag
;
pt1_vector    equ    000006h                ;timer 1 interrupt vector offset
evcnt_vector  equ    000008h                ;event counter interrupt vector offset
evcnt         equ    003000h                ;program start address offset
br_io         equ    0ffh                  ;base reg. address (set i/o area)
pt_mode0      equ    00ff30h                ;event counter timer mode set reg. 0
pt_mode1      equ    00ff31h                ;event counter mode set reg. 1
pt_mode2      equ    00ff32h                ;programmable timer mode set reg. 2
rld0          equ    00ff33h                ;event counter reload data
rld1          equ    00ff34h                ;programmable timer 1 reload data
ptd0          equ    00ff35h                ;event counter counting data
ptd1          equ    00ff36h                ;programmable timer 1 counter data
;
intr_pr1      equ    00ff21h                ;interrupt priority reg. 1
intr_en1      equ    00ff23h                ;interrupt enable reg. 1
intr_fac1     equ    00ff25h                ;interrupt factor flag reg. 1
;
        data
pre_count:    db    [1]                    ;previous event counter data
count:        db    [1]                    ;present event counter data
ovf_flag:     db    [1]                    ;event counter overflow flag
        code

```

**Vector address setting for 8-bit event counter interrupt**

```

intr_vectors:
        org    intr_vectors+pt1_vector
        dw    pt1_intr
;
        org    intr_vectors+evcnt_vector
        dw    evcnt_intr                    ;event counter overflow interrupt
;

```

**(3) Initialization for 8-bit event counter**

```

        org    intr_vectors+evcnt
timerdata8_2: db    250                    ;timer 1 reload data (4msec at 4mhz/64)
;*****
;*
;* 8-bit event counter (timer 0) counting between 4msec (reload timer 1) *
;*
;*****
;*** initialize routine
evcnt_init:
        ld    br,#br_io                    ;set br reg. address to 0ffxxh
        carl  osc1toosc3                    ;change osc1 to osc3 ***
        ld    a,[lod vdd_ngf]
        cp    a,#0ffh
        jrl   z,evcnt_init01
;
;model6=8-bit, chsel=timer 0, pulse output=off, cksel1=fosc3, cksel0=don't care
        ld    [br:low pt_mode0],#00000011b
        ld    a,#0ffh
        ld    [br:low rld0],a                ;set event counter init data (max.)
        ld    [lod pre_count],a            ;pre event counter data set
        ld    a,[loc timerdata8_2]
        ld    [br:low rld1],a                ;set reload data (timer 1)
;pt0:evcnt=event counter, fcsel=with noise rejector, plpol=falling edge
;pscl&0=don't care, rldm0=reload, pset0=preset, prrun0=stop
        ld    [br:low pt_mode1],#11000110b
;pt1:psc=fosc3/64, rldm1=reload, pset1=preset
        ld    [br:low pt_mode2],#00011110b
        or    [br:low intr_pr1],#00001100b    ;set pt=/irq3
        or    [br:low intr_en1],#11000000b    ;ept1&0 intr. en.
        or    [br:low pt_mode1],#00000001b    ;start event counter
        or    [br:low pt_mode2],#00000001b    ;start timer 1

```

## Source List

```

        ld    a,sc
        and  a,#00111111b
        or   a,#10000000b
        ld   sc,a                ;i0 flag clear (en. /irq3 intr.)
        xor  a,a
        ld   [lod ovf_flag],a    ;overflow flag clear
;*****
;*** start event counter (timer 0) and programmable timer 1 interrupt
;   (user program)
;
loop:
        ld   a,[lod ovf_flag]
        cp   a,#0ffh            ;event counter overflow ?
        jrs  nz,evcnt_init00     ;--> normal
;*****
;*** event counter overflow processing
;   (user program)
;
        jrs  event_init02
;*****
;*** normal processing
event_init00:
;   (user program)
;
event_init02:
        jrs  loop                ;-->
;*****
;*** end processing
        and  [br:low pt_mode1],#11111110b    ;stop event counter
        and  [br:low pt_mode2],#11111110b    ;stop timer 1
event_init01:
        carl osc3toosc1          ;change osc3 to osc1 ***
        ret

```

**(3) Interrupt processing for 8-bit event counter**

```

;*****
;*
;*   programmable timer 1 interrupt processing routine (reload mode)
;*
;*****
pt1_intr:
        push ale
;
        ld   br,#br_io          ;set br reg. address to 0ffxxh
;
        ld   a,[br:low ptd0]    ;read event counter counting data
        ld   [lod count],a      ;set present event counter data
        and  [br:low pt_mode1],#11111110b    ;event counter stop
        or   [br:low pt_mode1],#00000010b    ;set event counter next data (max.)
        ld   a,[lod pre_count]
        sub  a,[lod count]      ;a-reg. = input count number (4 msec)
;
;
;   programmable timer 1 processing (based on event counter counting data)
;
;
        ld   a,[lod count]
        ld   [lod pre_count],a  ;move event counter data p(i-1) <- p(i)
        and  [br:low intr_fac1],#10000000b    ;clear fpt1 interrupt flag
        pop  ale
        rete

```

*Source List*

```

;*****
;*
;* event counter (timer 0) interrupt processing routine (counter overflow) *
;*
;*****
evcnt_intr:
    push    ale
;
    ld      br,#br_io                ;set br reg. address to 0ffxxh
;
    ld      a,#0ffh
    ld      [lod ovf_flag],a        ;event counter overflow flag set
    and     [br:low pt_model],#11111110b ;event counter stop
;
;
; event counter overflow processing
;
;
    and     [br:low intr_fac1],#01000000b ;clear fpt0 interrupt flag
    pop     ale
    rete
    end

```

## Source List

**Control of programmable timer 4**

```

        external    osc1toosc3,osc3toosc1
        external    vdd_ngf
        public      measure_init,measure_intr
        public      count,ovf_flag,klx_intr
;
measure_vector equ 000006h           ;measure interrupt vector offset
klx_vector     equ 00000ah           ;klx interrupt vector offset
pm             equ 003000h           ;program start address offset
br_io         equ 0ffh              ;base reg. address (set i/o area)
pt_mode0      equ 00ff30h           ;pulse width measure mode set reg. 0
pt_model      equ 00ff31h           ;pulse width measure mode set reg. 1
rld0          equ 00ff33h           ;pulse width measure (low) reload data
rld1          equ 00ff34h           ;pulse width measure (high) reload data
ptd0          equ 00ff35h           ;pulse width measure (low) count data
ptd1          equ 00ff36h           ;pulse width measure (high) count data
sik1          equ 00ff51h           ;interrupt selection reg. for klx
kcpl          equ 00ff53h           ;interrupt comparison reg. for klx
kld           equ 00ff55h           ;input data from klx
;
intr_pr1      equ 00ff21h           ;interrupt priority reg. 1
intr_en1      equ 00ff23h           ;interrupt enable reg. 1
intr_fac1     equ 00ff25h           ;interrupt factor flag reg. 1
;
        data
count:        dw    [1]             ;pulse width measured data
ovf_flag:     db    [1]             ;event counter overflow flag
        code

```

**Vector address setting for 16-bit pulse width measurement timer interrupt**

```

intr_vectors:
        org    intr_vectors+measure_vector
        dw    measure_intr           ;pulse width measure overflow interrupt
;
        org    intr_vectors+klx_vector
        dw    klx_intr              ;klx interrupt processing routine
;

```

**(4) Initialization for 16-bit pulse width measurement timer**

```

        org    intr_vectors+pm
;*****
;*
;* 16-bit pulse width measurement (timer 0) between k10 "low" input term *
;*
;*****
;*** initialize routine
measure_init:
        ld    br,#br_io             ;set br reg. address to 0ffxxh
        carl  osc1toosc3            ;change osc1 to osc3 ***
        ld    a,[lod vdd_ngf]       ;vdd ng flag
        cp    a,#0ffh
        jrl   z,measure_init01
;mode16=16-bit,chsels=timer 0,pulse output=off,cksel1=don't care,cksel0=fosc3
        ld    [br:low pt_mode0],#00011001b
        ld    ba,#0ffffh
        ld    [lod rld0],ba         ;set measure counter init data (max.)
;pt0:evcnt=timer,fcsel=pulse width measurement,plpol=low level measurement
;psc=fosc3/1,rldm0=reload,pset0=preset,prun0=stop
        ld    [br:low pt_model],#01000110b
        ld    [br:low kcpl],#00000001b ;k10 falling edge ("h" -> "l")
        ld    [br:low sik1],#00000001b ;k10 interrupt enable
        or    [br:low intr_pr1],#00001111b ;set pt & pk1=/irq3
        or    [br:low intr_en1],#10100000b ;ept1 & ekl intr. en.
        or    [br:low pt_model],#00000001b ;start pulse measurement
        ld    a,sc
        and   a,#00111111b
        or    a,#10000000b
        ld    sc,a                 ;i0 flag clear (en. /irq3 intr.)
        xor   a,a
        ld    [lod ovf_flag],a     ;overflow flag clear

```

Source List

```

;*****
;*** start measure counter (16-bit timer 0)
;   (user program)
;
wait_loop:
    ld    a,[lod ovf_flag]
    cp    a,#0ffh                ;measure counter overflow ?
    jrs   nz,measure_init00      ;--> normal
;*****
;*** measure counter overflow processing
;   (user program)
;
    jrs   measure_init02
;*** normal processing
measure_init00:
;   (user program)
;
measure_init02:
    jrs   wait_loop              ;-->
;*****
;*** end processing
    and   [br:low pt_model],#1111110b    ;stop measure counter
measure_init01:
    carl  osc3tooscl             ;change osc3 to osc1 ***
    ret

```

**(4) Interrupt processing for 16-bit pulse width measurement timer**

```

;*****
;*
;* measure counter (16-bit timer 0) interrupt processing routine (overflow) *
;*
;*****
measure_intr:
    push  ale
;
    ld    br,#br_io              ;set br reg. address to 0ffxxh
;
    ld    a,#0ffh
    ld    [lod ovf_flag],a        ;event counter overflow flag set
    and   [br:low pt_model],#1111110b ;measure counter stop
;
;
;   measure counter overflow processing
;
;
    and   [br:low intr_fac1],#10000000b ;clear fpt1 interrupt flag
    pop   ale
    rete
;*****
;*
;* klx interrupt processing routine *
;*
;*****
klx_intr:
    push  ale
;
    ld    br,#br_io              ;set br reg. address to 0ffxxh
;
    bit   [br:low kcpl],#00000001b    ;kcp setting ?
    jrs   z,klx_intr01
;falling edge -> rising edge
    and   [br:low kcpl],#1111110b    ;set rising edge
    jrs   klx_intr00
;rising edge -> falling edge
klx_intr01:
    or    [br:low kcpl],#00000001b    ;set falling edge
    ld    ba,[lod ptd0]
    ld    [lod count],ba            ;read measure count data
    or    [br:low pt_model],#00000010b ;set measure counter init data (max.)
klx_intr00:
    and   [br:low intr_fac1],#00100000b ;clear fkl interrupt flag
    pop   ale
    rete
    end

```

## Source List

**Control of programmable timer 5**

```

        external   osc1toosc3,osc3toosc1
        external   vdd_ngf
        public     pulsout_init
;
br_io      equ     0ffh                ;base reg. address (set i/o area)
pt_mode0   equ     00ff30h            ;programmable timer mode set reg. 0
pt_model   equ     00ff31h            ;programmable timer mode set reg. 1
rld0       equ     00ff33h            ;programmable timer 0 reload data
rld1       equ     00ff34h            ;programmable timer 1 reload data
hizr2      equ     00ff71h            ;r2x output control reg.
r2d        equ     00ff75h            ;r2x output data
;
intr_pr1   equ     00ff21h            ;interrupt priority reg. 1
intr_en1   equ     00ff23h            ;interrupt enable reg. 1
intr_fac1  equ     00ff25h            ;interrupt factor flag reg. 1
;
        code

(5) 16-bit reload timer pulse output

;pulse output=66.4ms(approx. 15hz)
timerdata16: dw 33200                ;timer16 reload data (33.2ms at 4mhz/4)
;*****
;*
;*      pulse out (16-bit) control
;*
;*****
;*** initialize routine
pulsout_init:
        ld      br,#br_io             ;set br reg. address to 0ffxxh
        carl   osc1toosc3             ;change osc1 to osc3 ***
        ld      a,[lod vdd_ngf]       ;vdd ng flag
        cp     a,#0ffh
        jrl   z,pulsout_init00
;
        or     [br:low r2d],#10000000b ;r27="h" (enable ptout)
        and    [br:low hizr2],#01111111b ;r27=complementary output
;mode16=16-bit,chsels=timer0,ptout=off,cksel1=don't care,cksel0=fosc3
        ld     [br:low pt_mode0],#00011001b
        ld     ba,[loc timerdata16]   ;set 16-bit counter data (timer 0 & 1)
        ld     [lod rld0],ba
;pt0:evcnt=timer,fcsel=normal timer,plpol=don't care,psc=fosc3/4,rldm0=reload
;psel0=preset
        ld     [br:low pt_model1],#00001110b
        or     [br:low pt_model1],#00000001b ;start timer 0
        or     [br:low pt_mode0],#00000100b ;start ptout
;*****
;*** start pulse out (16-bit)
;      (user program)
;
;*****
;*** end processing
        and    [br:low pt_mode0],#11111011b ;stop ptout
        and    [br:low pt_model1],#11111110b ;stop timer 0
pulsout_init00:
        carl   osc3toosc1             ;change osc3 to osc1 ***
        ret
        end

```



# 13 LCD CONTROLLER

## I/O Map

Address	Bit	Name	Function	1	0	SR	R/W	Comment		
00FF10	D7	–	–	–	–	–		Constrantry "0" when being read		
	D6	–	–	–	–	–				
	D5	–	–	–	–	–				
	D4	LCCLK	CL output control for expanded LCD driver		On	Off	0	R/W		
	D3	LCFRM	FR output control for expanded LCD driver		On	Off	0	R/W		
	D2	DTFNT	LCD dot font selection		5 x 5 dots	5 x 8 dots	0	R/W		
	D1	LDUTY	LCD drive duty selection		1/16 duty	1/32 duty	0	R/W		
D0	SGOUT	R/W register		1	0	0	R/W	Reserved register		
00FF11	D7	–	–	–	–	–		"0" when being read		
	D6	DSPAR	LCD display memory area selection		Display area 1	Display area 0	0	R/W		
	D5	LCDC1	LCD display control		-----	-----	0	R/W	These bits are reset to (0, 0) when SLP instruction is executed.	
	D4		LCDC0	LCDC1						LCDC0
			1	1	All LCDs lit					
			1	0	All LCDs out					
			0	1	Normal display					
		0	0	Drive off						
D3	LC3	LCD contrast adjustment		-----	-----	0	R/W			
D2	LC2	LC3	LC2					LC1	LC0	Contrast
		1	1					1	1	Dark
D1	LC1	1	1					1	0	:
		:	:					:	:	:
D0	LC0	0	0	0	0	Light				

\*1 When 1/8 duty has been selected by mask option, setting of this register becomes invalid.

## Specifications

### Control of LCD controller

#### (1) *lcd\_init: Initialization for LCD controller*

Sets the LCD controller as follows:

- LCD dot matrix type      5 x 8
- LCD drive duty            1/32
- LCD display control      Normal display
- Contrast                    Middle (8/16)
- CL output                  ON
- FR output                  ON

#### (2) *control\_example, display\_frame, display\_1ch: Display control*

By specifying the front address of the string stored in memory and the display memory address (display position), data in the character generator table are written to display memory and are shown on the LCD panel.

The message to be displayed is an ASCII code string and "00H" should be added to the end of the string as an end mark.

Display example: "e" "0" "c" "8" "8" "3" "1" "6" 00H

5 x 8-dot character data are stored in the character generator `ascii_table` in ASCII code order. A character is configured with 5 bytes of data. Consequently, data for the character code "n" should be stored in 5 bytes from `ascii_table + (n x 5)` address.

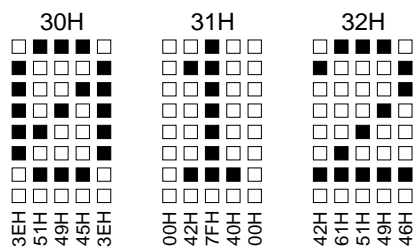

Fig. 13.1 Configuration of character data

## Notes

- (1) R26 and R25 terminals are common to the normal DC output port and CL output, and FR output. When performing CL and FR output to expand the LCD driver externally, set the R26 and R25 registers at "1" and control the signal ON/OFF using the LCCLK and LCFRM registers.
- (2) Maximum drive dot number of the E0C88348/317/316 is 1,632 dots (51 segments × 32 commons).
- (3) Maximum drive dot number of the E0C88308 is 1,312 dots (41 segments × 32 commons).

Flowchart

(1) Initialization for LCD controller

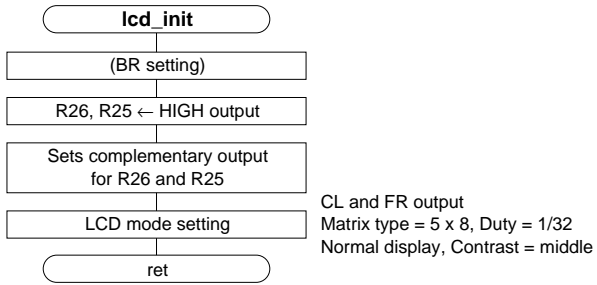

(2) Display control

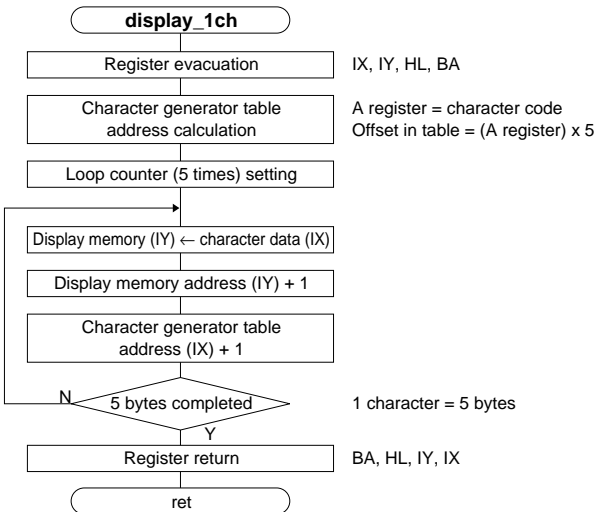
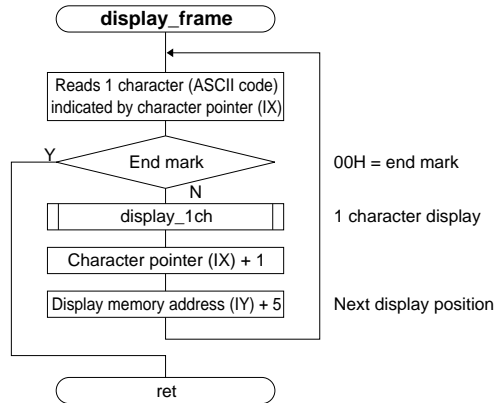
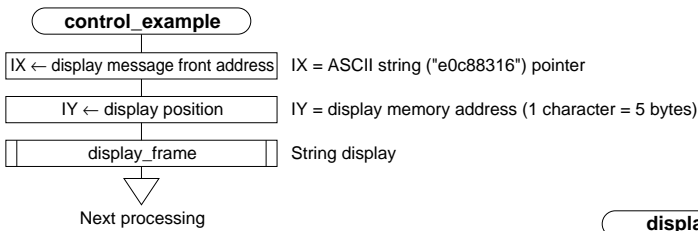

## Source List

**Control of LCD controller**

```

        public      lcd_init,display_frame,display_lch
;
offset      equ      30h*5                ;ascii code table address offset
br_io       equ      0ffh                 ;base reg.address (set i/o area)
lcd_mode0   equ      00ff10h             ;lcd controller mode set reg. 0
lcd_model   equ      00ff11h             ;lcd controller mode set reg. 1
h2r2        equ      00ff71h             ;r2x output control data
r2d         equ      00ff75h             ;r2x output data
;
lcd_ram0    equ      00f800h             ;lcd ram line 0 top address
lcd_ram1    equ      00f900h             ;lcd ram line 1 top address
lcd_ram2    equ      00fa00h             ;lcd ram line 2 top address
lcd_ram3    equ      00fb00h             ;lcd ram line 3 top address
;
        code

```

**(1) Initialization for LCD controller**

```

;*****
;*
;*      lcd display control
;*
;*****
;*** initialize routine
lcd_init:
        ld      br,#br_io                ;set br reg. address to 0ffxxh
        or      [br:low r2d],#01100000b   ;r26,r25="h" (fr,cr enable)
        and     [br:low h2r2],#1001111b   ;r26,r25=complementary output
;lcclk,lcfrm=on,dttyp=5*8,lduty=1/32
        ld      [br:low lcd_mode0],#00011000b
;srssel=don't care (when 1/32),lcdc=normal,lc=middle contrast
        ld      [br:low lcd_model],#00011000b
        ret
;

```

(1)

**(2) Display control**

```

;*****
;*** control program example routine
control_example:
        ld      ix,#loc frame00          ;display message
        ld      iy,#lod lcd_ram0+1*5    ;display address
        call   display_frame            ;display frame ***
;
;*****
;*
;*      dispaly frame
;*      ix : message top address
;*      iy : display top address
;*
;*****
;*** control routine
display_frame:
        ld      a,[ix]
        cp      a,#00h                  ;end mark ?
        jrs    z,display_frame00        ;exit
;
        cals   display_lch              ;display 1 character ***
        inc    ix
        add    iy,#5                    ;display address + 5 (5*8 dots)
        jrs    display_frame            ;up end mark detect
;
display_frame00:
        ret

```

(2)

Source List

```

;*****
;*
;*      display 1 character (from ascii code to 5*8 dots dot matrix) *
;*      ix : message pointer index *
;*      iy : store pointer index *
;*
;*****
display_lch:
    push  ix
    push  iy
    push  hl
    push  ba
    ld    l,#5
    mlt
    add   hl,#loc ascii_table ;hl <- a-reg*5
    ld    ix,hl                ;hl <- hl + ascii_table top address
    ld    b,#5                 ;5 bytes data
display_lchar00:
    ld    [iy],[ix]
    inc  ix
    inc  iy
    djr  nz,display_lchar00
;
    pop  ba
    pop  hl
    pop  iy
    pop  ix
    ret
;
;*****
;*** message frame example
frame00:
    ascii "e0c88316"
    db    00h                ;end mark
;
;*****
;*** ascii character table (example)
ascii_table:
;
;      character code 00h to 2fh have not been used in this example
;
    org  ascii_table+offset
    db   3eh,51h,49h,45h,3eh ;"0",30h
    db   00h,42h,7fh,40h,00h ;"1",31h
    db   42h,61h,51h,49h,46h ;"2",32h
;
;      (user defined)
;      character generator table (5*8 dots)
;      (user defined)
end

```

(2)

# 14 SOUND GENERATOR

## I/O Map

Address	Bit	Name	Function	1	0	SR	R/W	Comment	
00FF44	D7	–	–	–	–	–		Constrany "0" when being read	
	D6	BZSTP	One-shot buzzer forcibly stop	Forcibly stop	No operation	–	W		
	D5	BZSHT	One-shot buzzer trigger/status	R	Busy	Ready	0		R/W
				W	Trigger	No operation			
	D4	SHTPW	One-shot buzzer duration width selection	125 msec	31.25 msec	0	R/W		
	D3	ENRTM	Envelope attenuation time	1 sec	0.5 sec	0	R/W		
	D2	ENRST	Envelope reset	Reset	No operation	–	W		"0" when being read
	D1	ENON	Envelope On/Off control	On	Off	0	R/W		*1
D0	BZON	Buzzer output control	On	Off	0	R/W			
00FF45	D7	–	–	–	–	–		"0" when being read	
	D6	DUTY2	Buzzer signal duty ratio selection					0	R/W
			DUTY2-1		Buzzer frequency (Hz)				
			2	1	0	4096.0 3276.8 2730.7 2340.6			
						2048.0 1638.4 1365.3 1170.3			
	D5	DUTY1	0	0	0	8/16 8/20 12/24 12/28		0	R/W
			0	0	1	7/16 7/20 11/24 11/28			
			0	1	0	6/16 6/20 10/24 10/28			
			0	1	1	5/16 5/20 9/24 9/28			
	D4	DUTY0	1	0	0	4/16 4/20 8/24 8/28		0	R/W
1			0	1	3/16 3/20 7/24 7/28				
1			1	0	2/16 2/20 6/24 6/28				
1			1	1	1/16 1/20 5/24 5/28				
D3	–	–	–	–	–		"0" when being read		
D2	BZFQ2	Buzzer frequency selection					0	R/W	
		BZFQ2	BZFQ1	BZFQ0	Frequency (Hz)				
D1	BZFQ1	0	0	0	4096.0		0	R/W	
		0	0	1	3276.8				
		0	1	0	2730.7				
		0	1	1	2340.6				
D0	BZFQ0	1	0	0	2048.0		0	R/W	
		1	0	1	1638.4				
		1	1	0	1365.3				
		1	1	1	1170.3				

\*1 Reset to "0" during one-shot output.

Specifications

**Control of sound generator**

**(1) sound\_init: Initialization for sound generator**

Enables the buzzer output from R50 terminal.

**(2) normal\_init, normal\_on, normal\_off: Normal buzzer output**

The normal\_init routine sets the duty ratio of the buzzer signal to maximum and the frequency to 4,096 Hz. There is buzzer output when normal\_on has been called until normal\_off is called.

**(3) envelope\_init, envelope\_on, envelope\_reset, envelope\_off: Buzzer output with digital envelope**

The envelope\_init routine sets the buzzer signal frequency to 4,096 Hz and the envelope attenuation time to 1 sec and then turns the envelope ON.

There is buzzer output when envelope\_on has been called until envelope\_off is called.

The envelope\_reset routine re-sets the buzzer signal frequency to 2,048 Hz and the envelope attenuation time to 0.5 sec and then resets the envelope. The envelope is reset by calling envelope\_reset during output period of a buzzer with envelope.

**(4) oneshot\_ready, oneshot\_on, oneshot\_off: One-shot buzzer output**

The oneshot\_ready routine sets the one-shot buzzer pulse width to 125 msec and waits until the one-shot buzzer output has shifted to READY status. One-shot buzzer output is done by calling oneshot\_on. Buzzer output is 125 msec when called by oneshot\_on, but even in that time, the one-shot buzzer output can be forcibly terminated by calling oneshot\_off.

Flowchart

**(1) Initialization for sound generator**

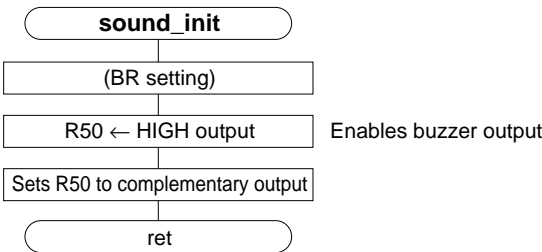

**(2) Normal buzzer output**

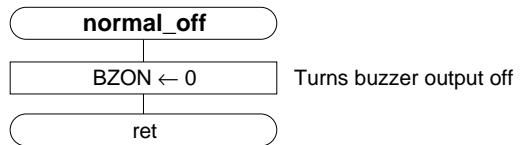
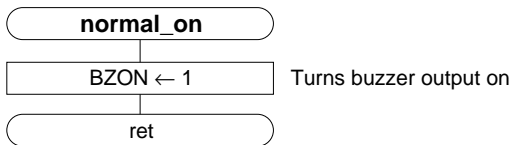
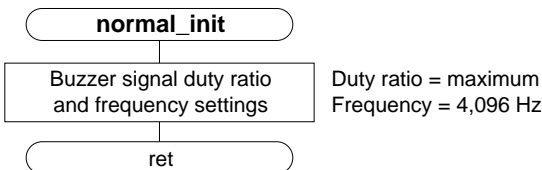

**Flowchart**

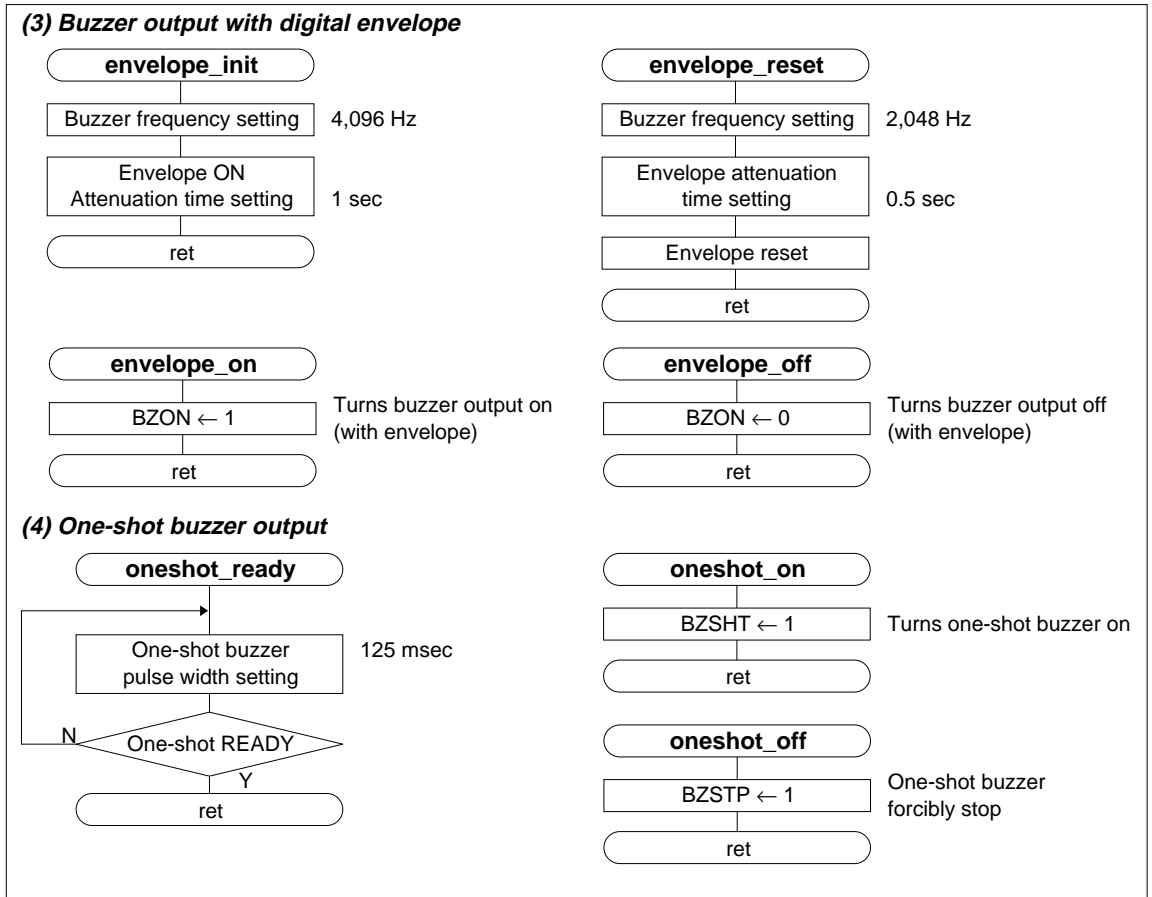

**Note**

The R50 terminal is common to the normal DC output port and the buzzer output. When a buzzer circuit has been configured with the R50 terminal, set the R5 register to "1" and control the signal ON/OFF using the BZON register.



Source List

**Control of sound generator**

```

        public      sound_init
        public      normal_init,normal_on,normal_off
        public      envelope_init,envelope_on,envelope_reset,envelope_off
        public      oneshot_ready,oneshot_on,oneshot_off
;
br_io      equ      0ffh                ;base reg. address (set i/o area)
sound_mode0 equ      00ff44h           ;sound generator mode set reg. 0
sound_mode1 equ      00ff45h           ;sound generator mode set reg. 1
;
hxr_ex     equ      00ff70h           ;expand output control reg.
r5d        equ      00ff78h           ;r5x output data
        code
;

```

**(1) Initialization for sound generator**

```

;*****
;*
;*      sound genertator control
;*
;*****
sound_init:
        ld         br,#br_io           ;set br reg. address to 0ffxxh
        and        [br:low r5d],#11111110b ;r50="1" (bzon enable)
        and        [br:low hxr_ex],#10111111b ;r50=complementary output
        ret
;

```

**(2) Normal buzzer output**

```

;*****
;*** sound normal
normal_init:
        ld         [br:low sound_mode1],#00000000b ;duty=max.,bzfq=4096hz
        ret
;***
normal_on:
        or         [br:low sound_mode0],#00000001b ;bzon=enable
        ret
;***
normal_off:
        and        [br:low sound_mode0],#11111110b ;bzon=disable
        ret
;

```

**(3) Buzzer output with digital envelope**

```

;*****
;*** sound envelope
envelope_init:
        ld         [br:low sound_mode1],#00000000b ;duty=don't care,bzfq=4096hz
        or         [br:low sound_mode0],#00001010b ;enrtm=1sec,enon=on
        ret
;***
envelope_on:
        or         [br:low sound_mode0],#00000001b ;bzon=enable (with envelope)
        ret
;***
;envelope reset then on(change envelope release time & buzzer frequency)
envelope_reset:
        ld         [br:low sound_mode1],#00000100b ;duty=don't care,bzfq=2048hz
        ld         a,[br:low sound_mode0]
        and        a,#00000011b ;enrtm=0.5sec
        or         a,#00000100b ;envelope reset
        ld         [br:low sound_mode0],a
        ret
;***
envelope_off:
        and        [br:low sound_mode0],#11111110b ;bzon=disable
        ret
;

```

**Source List****(4) One-shot buzzer output**

```

;*****
;*** sound_oneshot
oneshot_ready:
    or    [br:low sound_mode0],#00010000b    ;one shot width=125ms
    bit   [br:low sound_mode0],#00100000b    ;one shot ready ?
    jrs   nz,oneshot_ready
;
    ret
;***
oneshot_on:
    ld    a,[br:low sound_mode0]
    and   a,#00011111b
    or    a,#00100000b
    ld    [br:low sound_mode0],a             ;one shot buzzer on
    ret
;***
oneshot_off:
    ld    a,[br:low sound_mode0]
    and   a,#00011111b
    or    a,#01000000b
    ld    [br:low sound_mode0],a           ;no status read stop
    ret
;
    end

```

(4)

# 15 ANALOG COMPARATOR

## I/O Map

Address	Bit	Name	Function	1	0	SR	R/W	Comment
00FF13	D7	-	-	-	-	-		Constantly "0" when being read
	D6	-	-	-	-	-		
	D5	-	-	-	-	-		
	D4	-	-	-	-	-		
	D3	CMP1ON	Comparator 1 On/Off control	On	Off	0	R/W	
	D2	CMP0ON	Comparator 0 On/Off control	On	Off	0	R/W	
	D1	CMP1DT	Comparator 1 data	+>-	+<-	0	R	
	D0	CMP0DT	Comparator 0 data	+>-	+<-	0	R	

## Specifications

### Control of analog comparator

**(1) comp\_init: Initialization for analog comparator**

Sets I/O port P17-P14 to the input mode in order to prevent a malfunction.

**(2) comp\_control: Data reading for analog comparator**

Sets the analog comparator to ON and reads the comparator data after calling a delay routine. Executes subsequent processing according to the results of the read.

## Flowchart

### (1) Initialization for analog comparator

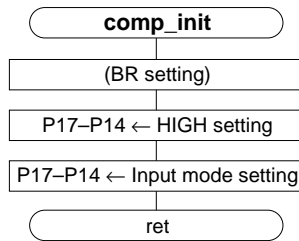

### (2) Data reading for analog comparator

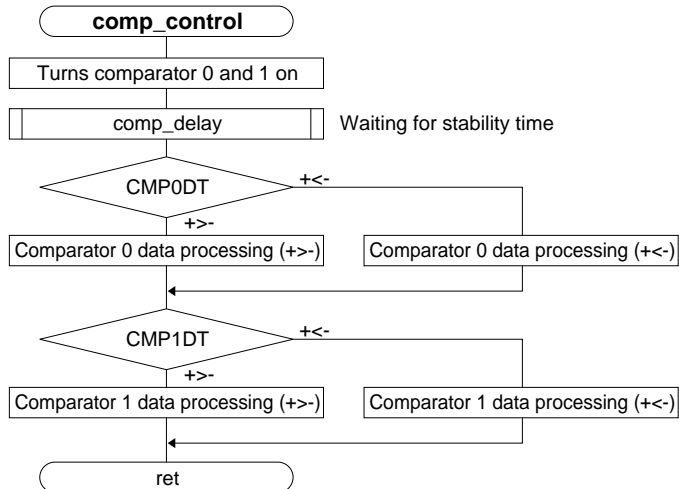

**Notes**

- (1) A delay routine for the operation stabilization waiting time (3 msec, maximum) of the analog comparator is not included in this program example, so it is necessary to create it using a hardware timer or software timer. (external call: comp\_delay)
- (2) P17–P14 terminals are common to the analog comparator inputs (CMPM0, CMPP0, CMPM1 and CMPP1) and the I/O port, and these are switched to I/O port terminals when the analog comparator is turned OFF. Consequently, for an I/O port which is used for an analog comparator, be sure to set in input mode.

**Source List****Control of analog comparator**

```

        external   comp_delay
        public     comp_init,comp_control
;
br_io      equ      0ffh           ;base reg. address (set i/o area)
comp_mode  equ      00ff13h        ;analog comparator mode set reg.
ioc1       equ      00ff61h        ;plx i/o control reg.
pld        equ      00ff63h        ;plx port data
code

```

**(1) Initialization for analog comparator**

```

;*****
;*
;*      comparator control
;*
;*****
;*** initialize routine
comp_init:
        ld      br,#br_io          ;set br reg. address to 0ffxxh
        or      [br:low pld],#11110000b ;set p17-14="h"
        and     [br:low ioc1],#00001111b ;set p17-14=input mode
        ret

```

(1)

**(2) Data reading for analog comparator**

```

;*****
;*** control routine
comp_control:
        or      [br:low comp_mode],#00001100b ;comparator 0&1 on
        carl   comp_delay              ;comparator stable delay ***
        bit     [br:low comp_mode],#00000001b ;comparator 0 on ?
        jrs    z,comp_control00
; comparator 0 : + > -
;
        jrs    comp_control01
; comparator 0 : + < -
comp_control00:
;
comp_control01:
        bit     [br:low comp_mode],#00000010b ;comparator 1 on ?
        jrs    z,comp_control02
; comparator 1 : + > -
;
        jrs    comp_control03
; comparator 1 : + < -
comp_control02:
;
; comparator processing end
comp_control03:
        and     [br:low comp_mode],#00001100b
        ret
;
        end

```

(2)

# 16 SVD (SUPPLY VOLTAGE DETECTION) CIRCUIT

I/O Map

Address	Bit	Name	Function	1	0	SR	R/W	Comment	
00FF12	D7	–	–	–	–	–		Constantry "0" when being read	
	D6	–	–	–	–	–			
	D5	SVDSP	SVD auto-sampling control	On	Off	0	R/W	These registers are reset to "0" when	
	D4	SVDON	SVD continuous sampling control/status	R Busy On	R Ready Off	1→0*1 0	R/W	SLP instruction is executed.	
	D3	SVD3	SVD detection level SVD3 SVD2 SVD1 SVD0 Detection level				X	R	
	D2	SVD2		1 1 1 1	Level 15			X	R
	D1	SVD1		1 1 1 0	Level 14			X	R
				⋮ ⋮ ⋮ ⋮	⋮				
	D0	SVD0		0 0 0 0	Level 0			X	R

\*1 After initial reset, this status is set "1" until conclusion of hardware first sampling.

\*2 Initial values are set according to the supply voltage detected at first sampling by hardware. Until conclusion of first sampling, SVD0–SVD3 data are undefined.

Specifications

**Control of SVD circuit**

**(1) svd\_auto: Supply voltage detection in 1/4 Hz auto sampling mode**

After setting the 1/4 Hz auto-sampling mode to turn the SVD circuit ON, reads out SVD detection data into the A register.

**(2) svd\_continue: Supply voltage detection in continuously sampling mode**

Sets the continuous sampling mode (cancels the 1/4 Hz auto-sampling mode) to turn the SVD circuit ON, and reads out SVD detection data into A register after calling a delay routine.

Flowchart

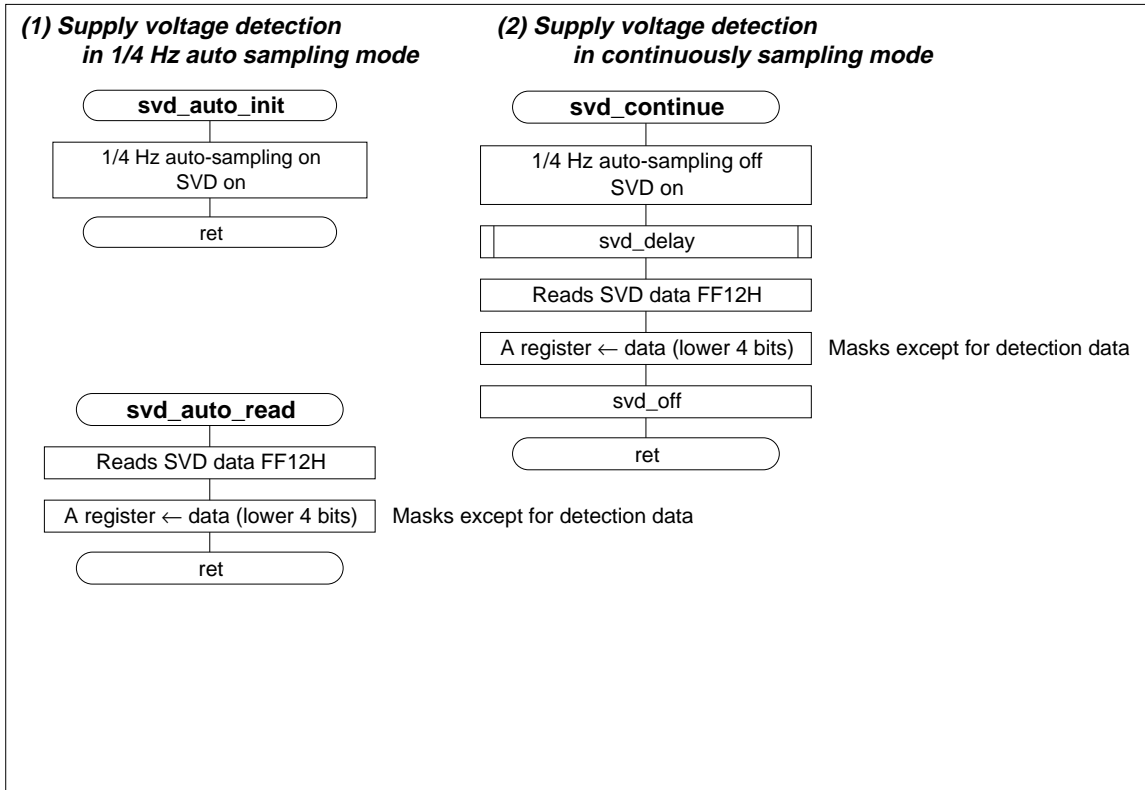

**Notes**

- (1) A delay routine that waits data decision time (approximately 7.8 msec or more) for the SVD circuit has not been included in this program example, so it is necessary to create a separate routine using a hardware timer or software timer. (external call: svd\_delay)
- (2) In the continuous sampling mode, when reading the detection data without waiting the data decision time (approximately 7.8 msec or more), previous data that has not been updated will be read.

**Source List****Control of SVD circuit**

```

        external   svd_delay
        public     svd_auto_init,svd_auto_read,svd_contine
;
br_io      equ     0ffh           ;base reg. address (set i/o area)
svd_mode   equ     00ff12h       ;supply voltage detector mode set reg.
        code
;
(1) Supply voltage detection in 1/4 Hz auto sampling mode
;*****
;*          svd control          *
;*          *                    *
;*          *                    *
;*****
;*** auto sampling mode
svd_auto_init:
        or      [br:low svd_mode],#00100000b   ;auto sampling
        ret
;
;
        ld     a,[br:low svd_mode]             ;read svd data
        and   a,#0fh
        ret
;
(2) Supply voltage detection in continuously sampling mode
;*****
;*** continuous mode
svd_continue:
        ld     a,[br:low svd_mode]
        and   a,#00011111b                     ;auto sampling off
        or    a,#00010000b                     ;svd on
        ld     [br:low svd_mode],a
;
;
        call  svd_delay                         ;svd stable delay
;
        ld     a,[br:low svd_mode]             ;read svd data
        and   a,#0fh
        and   [br:low svd_mode],#00001111b    ;svd off
        ret
;
        end

```

# 17 INTERRUPT (EXCEPTION) PROCESSING

I/O Map

Address	Bit	Name	Function	1	0	SR	R/W	Comment	
00FF20	D7	PK01	K00–K07 interrupt priority register	PK01 PK00 PSIF1 PSIF0 PSW1 PSW0	Priority level	0	R/W		
	D6	PK00							
	D5	PSIF1	Serial interface interrupt priority register	PTM1 PTM0	Level 3	0	R/W		
	D4	PSIF0							
	D3	PSW1	Stopwatch timer interrupt priority register	1 1	Level 2	0	R/W		
	D2	PSW0							
D1	PTM1	Clock timer interrupt priority register	0 0	Level 1	0	R/W			
D0	PTM0								
00FF21	D7	–	–	–	–	–	–	Constantly "0" when being read	
	D6	–	–	–	–	–	–		
	D5	–	–	–	–	–	–		
	D4	–	–	–	–	–	–		
	D3	PPT1	Programmable timer interrupt priority register	PPT1 PPT0 PK11 PK10	Priority level	0	R/W		
	D2	PPT0							
D1	PK11	K10 and K11 interrupt priority register	1 0 0 1 0 0	Level 2 Level 1 Level 0	0	R/W			
D0	PK10								
00FF22	D7	–	–	–	–	–	–	"0" when being read	
	D6	ESW100	Stopwatch timer 100 Hz interrupt enable register	Interrupt enable	Interrupt disable	0	R/W		
	D5	ESW10							Stopwatch timer 10 Hz interrupt enable register
	D4	ESW1							Stopwatch timer 1 Hz interrupt enable register
	D3	ETM32	Clock timer 32 Hz interrupt enable register						
	D2	ETM8							Clock timer 8 Hz interrupt enable register
	D1	ETM2	Clock timer 2 Hz interrupt enable register						
	D0	ETM1	Clock timer 1 Hz interrupt enable register						
00FF23	D7	EPT1	Programmable timer 1 interrupt enable register					Interrupt enable	Interrupt disable
	D6	EPT0	Programmable timer 0 interrupt enable register						
	D5	EK1	K10 and K11 interrupt enable register						
	D4	EK0H	K04–K07 interrupt enable register						
	D3	EK0L	K00–K03 interrupt enable register						
	D2	ESERR	Serial I/F (error) interrupt enable register						
	D1	ESREC	Serial I/F (receiving) interrupt enable register						
	D0	ESTRA	Serial I/F (transmitting) interrupt enable register						
00FF24	D7	–	–	–	–	–	–	"0" when being read	
	D6	FSW100	Stopwatch timer 100 Hz interrupt factor flag	(R)	(R)	0	R/W		
	D5	FSW10	Stopwatch timer 10 Hz interrupt factor flag	Interrupt factor is generated	No interrupt factor is generated				
	D4	FSW1	Stopwatch timer 1 Hz interrupt factor flag						
	D3	FTM32	Clock timer 32 Hz interrupt factor flag						
	D2	FTM8	Clock timer 8 Hz interrupt factor flag	(W) Reset	(W) No operation				
	D1	FTM2	Clock timer 2 Hz interrupt factor flag						
	D0	FTM1	Clock timer 1 Hz interrupt factor flag						
00FF25	D7	FPT1	Programmable timer 1 interrupt factor flag	(R)	(R)			0	R/W
	D6	FPT0	Programmable timer 0 interrupt factor flag	Interrupt factor is generated	No interrupt factor is generated				
	D5	FK1	K10 and K11 interrupt factor flag						
	D4	FK0H	K04–K07 interrupt factor flag						
	D3	FK0L	K00–K03 interrupt factor flag	(W) Reset	(W) No operation				
	D2	FSERR	Serial I/F (error) interrupt factor flag						
	D1	FSREC	Serial I/F (receiving) interrupt factor flag						
	D0	FSTRA	Serial I/F (transmitting) interrupt factor flag						

*Specifications***Interrupt (exception) processing****Setting of interrupt vector address****(1) main: Interrupt level setting and enables interrupt**

Sets an interrupt level ( $\overline{\text{IRQ3}}\text{--}\overline{\text{IRQ1}}$ ) as the below for all interrupts and enables interrupts in the initialization routine (example for 88316 single chip mode) which is executed by reset exception processing.

- Programmable timer interrupt      $\overline{\text{IRQ3}}$
- Input port interrupt                  $\overline{\text{IRQ3}}$
- Serial interface interrupt          $\overline{\text{IRQ2}}$
- Stopwatch timer interrupt          $\overline{\text{IRQ1}}$
- Clock timer interrupt                $\overline{\text{IRQ1}}$

**(2) zero\_div: Zero division exception processing****(3) watchdog: Watchdog timer ( $\overline{\text{NMI}}$ ) interrupt processing****(4) xxx\_intr: Interrupt processing for peripheral circuit***Notes*

- (1) The interrupt level ( $\overline{\text{IRQ3}}\text{--}\overline{\text{IRQ1}}$ ) can be set to adapt to the system.
- (2) Be sure to initialize peripheral circuits which use an interrupt and set interrupt generation conditions beforehand to enable each interrupt.
- (3) Interrupt processing for a peripheral circuit enables all interrupts, and exception processing with an interrupt vectors is a precondition. Since an interrupt flag is set by the generation of an interrupt regardless of the interrupt enable register and interrupt flags (I1 and I0), a procedure for polling interrupt factor flags by software can also be used.
- (4) Since the watchdog timer ( $\overline{\text{NMI}}$ ) interrupt cannot be masked, be sure to declare the watchdog timer ( $\overline{\text{NMI}}$ ) interrupt processing routine and the vector address, regardless of whether or not the watchdog timer is used.
- (5) To reset the interrupt factor flag, write "1" into the corresponding flags alone, using the AND or LD instruction. When the OR logic operation instruction has been used, "1" is written for the interrupt factor flags that have been set to "1" within the same address and those flags are then clear.
- (6) The interrupt flags (I1 and I0) have not been reset in the interrupt processing routine of this program example, so an interrupt lower than the set level is disabled at the time of generation. When you wish to accept the next interrupt after an interrupt has been generated, re-setting of the interrupt flags or resetting the interrupt factor flag is necessary after due consideration for the nesting level.
- (7) When permitting interrupt nesting, be careful of the stack size.
- (8) Vector addresses for software interrupts can be set up to 109 and to optional address (two bytes which begin with an even address) from 000026H to 0000FEH.
- (9) The vector addresses 000024H and 000025H cannot be used since this is a system reserved area.
- (10) In this program example for interrupt (exception) processing, the vector address setting and program have been allocated from 000100H for the sake of convenience.
- (11) Do not execute the SLP instruction for 2 msec after a  $\overline{\text{NMI}}$  interrupt has occurred (when fosc1 is 32.768 kHz).



Flowchart

**(1) Interrupt level setting and enables interrupt**

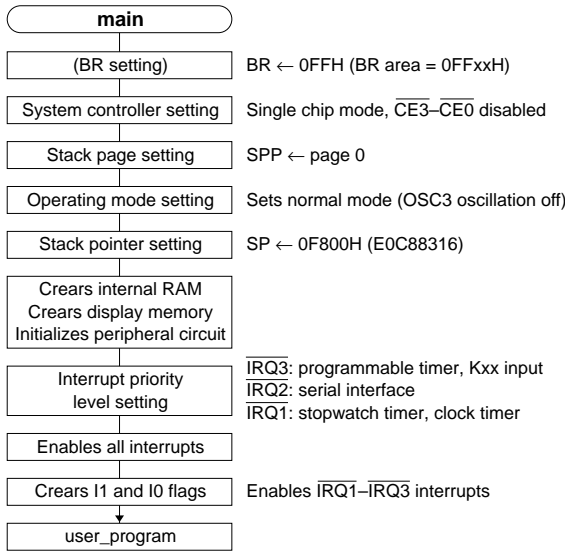

- Note:
- Internal RAM addresses and capacity of the E0C88308 are as follows:  
E0C88308: 00F000H-00F0FFH (256 bytes)
  - Memory map is different depending on the model and bus mode to be used.
  - The E0C88308 does not have a bus authority release function, K11 terminal or R51 terminal.

**(2) Zero division exception processing**

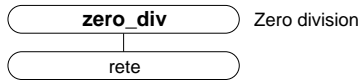

**(3) Watchdog timer (NMI) interrupt processing**

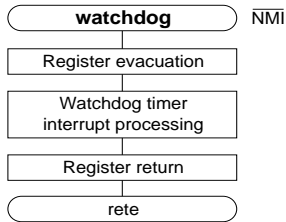

**(4) Interrupt processing for peripheral circuit**

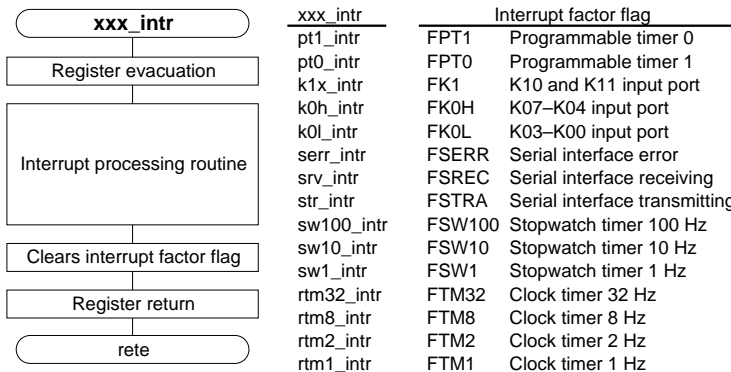

## Source List

**Interrupt (exception) processing**

```

external    user_program
public     main,zero_div,watch_dog
public     pt1_intr,pt0_intr
public     k1x_intr,k0h_intr,k0l_intr
public     serr_intr,srv_intr,str_intr
public     sw100_intr,sw10_intr,swl_intr
public     clock32_intr,clock8_intr,clock2_intr,clock1_intr
;
br_io      equ    0ffh                ;base reg. address (set i/o area)
mcu        equ    00ff00h             ;mcu mode system control reg.
spp        equ    00ff01h             ;stack pointer page address
mode       equ    00ff02h             ;mcu/mpu mode control address
sp_316     equ    00f800h             ;e0c88316 stack top address
intr_pr0   equ    00ff20h             ;interrupt priority reg. 0
intr_pr1   equ    00ff21h             ;interrupt priority reg. 1
intr_en0   equ    00ff22h             ;interrupt enable reg. 0
intr_en1   equ    00ff23h             ;interrupt enable reg. 1
intr_fac0  equ    00ff24h             ;interrupt factor reg. 0
intr_fac1  equ    00ff25h             ;interrupt factor reg. 1
;
reserve    equ    000024h             ;e0c88316 system reserve
soft_intr  ewu    000026h             ;software interrupt vector
offset     equ    000100h             ;program start address offset
code

```

**Setting of interrupt vector address**

```

intr_vectors:
;system interrupt vectors
dw    main                ;reset vector
dw    zero_div            ;zero divide
dw    watchdog            ;watchdog timer(/nmi)
;e0c88316 peripheral interrupt vectors (irq levels can set by software)
dw    pt1_intr            ;programmable timer 1 (/irq3)
dw    pt0_intr            ;programmable timer 0 (/irq3)
dw    k1x_intr            ;klx input port (/irq3)
dw    k0h_intr            ;k07-04 input port (/irq3)
dw    k0l_intr            ;k03-00 input port (/irq3)
dw    serr_intr           ;serial error (/irq2)
dw    srv_intr            ;serial receive (/irq2)
dw    str_intr            ;serial transmission (/irq2)
dw    sw100_intr          ;stopwatch 100hz (/irq1)
dw    sw10_intr           ;stopwatch 10hz (/irq1)
dw    swl_intr            ;stopwatch 1hz (/irq1)
dw    clock32_intr        ;clock timer 32hz (/irq1)
dw    clock8_intr         ;clock timer 8hz (/irq1)
dw    clock2_intr         ;clock timer 2hz (/irq1)
dw    clock1_intr         ;clock timer 1hz (/irq1)
;e0c88316 system reserve
org    intr_vectors+reserve
;software interrupt vectors (i.e bios handler and/or general purpose routine(s))
org    intr_vectors+soft_intr
;

```

Source List

**(1) Interrupt level setting and enables interrupt**

```

org intr_vectors+offset
;*****
;*
;* main routine (mcu single chip mode)
;*
;*****
main:
;
; ld br,#br_io
;mcu & spp write icludes system interrupt flag reset
; ld [br:low mcu],#00110000b
; ld [br:low spp],#0h
; ld [br:low mode],#00000000b
; ld sp,#sp_316
;
;
; ram,lcd ram clear and i/o initialize
;
;
;pk0(/irq3),psif(/irq2),psw(/irq1),ptm(/irq1)
; ld [br:low intr_pr0],#11100101b
;ppt(/irq3),pk1(/irq3)
; ld [br:low intr_pr1],#00000101b
;esw100,10,1(en),etm32,8,2,1(en.)
; ld [br:low intr_en0],#01111111b
;ept(en.),ek1(en.)ek0b(en.),ek0a(en.),eserr(en.),esrec(en.),estra(en.)
; ld [br:low intr_en1],#11111111b
;en. /nmi,/irq3,/irq2,/irq1
; and sc,#00111111b ;il & i0 flag clear
;wait for interrupt
; jrl user_program
;

```

] (1)

**(2) Zero division exception processing**

```

;*****
;*
;* zero divide
;*
;*****
zero_div:
; rete

```

] (2)

**(3) Watchdog timer ( $\overline{\text{NMI}}$ ) interrupt processing**

```

;*****
;*
;* watchdog timer (/nmi)
;*
;*****
watchdog:
; push ale
; ld br,#br_io ;set br reg. address to 0ffxxh
;
;watchdog timer (/nmi) interrupt processing
;
; pop ale
; rete

```

] (3)

## Source List

**(4) Interrupt processing for peripheral circuit**

```

;*****
;*
;*      programmable timer 1 (/irq3)
;*
;*****
pt1_intr:
    push  ale
;
;      programmable timer 1 interrupt processing
;
    and   [br:low_intr_fac1],#1000000b   ;clear fpt1 interrupt flag
    pop   ale
    rete
;*****
;*
;*      programmable timer 0 (/irq3)
;*
;*****
pt0_intr:
    push  ale
;
;      programmable timer 0 interrupt processing
;
    and   [br:low_intr_fac1],#0100000b   ;clear fpt0 interrupt flag
    pop   ale
    rete
;*****
;*
;*      klx input port (/irq3)
;*
;*****
klx_intr:
    push  ale
;
;      klx input port interrupt processing
;
    and   [br:low_intr_fac1],#0010000b   ;clear fk1 interrupt flag
    pop   ale
    rete
;*****
;*
;*      k0h input port (/irq3)
;*
;*****
k0h_intr:
    push  ale
;
;      k0h input port interrupt processing
;
    and   [br:low_intr_fac1],#0001000b   ;clear fk0b interrupt flag
    pop   ale
    rete
;*****
;*
;*      k0l input port 0 (/irq3)
;*
;*****
k0l_intr:
    push  ale
;
;      k0l input port interrupt processing
;
    and   [br:low_intr_fac1],#00001000b  ;clear fk0a interrupt flag
    pop   ale
    rete
;*****
;*
;*      serial error (/irq2)
;*
;*****
serr_intr:
    push  ale
;
;      serial error interrupt processing
;
    and   [br:low_intr_fac1],#00000100b  ;clear fserr interrupt flag
    pop   ale
    rete

```

(4)

(4)

(4)

(4)

(4)

(4)

Source List

```

;*****
;*
;*      serial receive (/irq2)
;*
;*****
srv_intr:
;
;      push  ale
;
;      serial receive interrupt processing
;
;      and   [br:low intr_fac1],#00000010b  ;clear fsrec interrupt flag
;      pop   ale
;      rete
;*****
;*
;*      serial transmission (/irq2)
;*
;*****
str_intr:
;
;      push  ale
;
;      serial transmission interrupt processing
;
;      and   [br:low intr_fac1],#00000001b  ;clear fstra interrupt flag
;      pop   ale
;      rete
;*****
;*
;*      stopwatch 100hz (/irq1)
;*
;*****
sw100_intr:
;
;      push  ale
;
;      stopwatch 100hz interrupt processing
;
;      and   [br:low intr_fac0],#01000000b  ;clear fsw100 interrupt flag
;      pop   ale
;      rete
;*****
;*
;*      stopwatch 10hz (/irq1)
;*
;*****
sw10_intr:
;
;      push  ale
;
;      stopwatch 10hz interrupt processing
;
;      and   [br:low intr_fac0],#00100000b  ;clear fsw10 interrupt flag
;      pop   ale
;      rete
;*****
;*
;*      stopwatch 1hz (/irq1)
;*
;*****
sw1_intr:
;
;      push  ale
;
;      stopwatch 1hz interrupt processing
;
;      and   [br:low intr_fac0],#00010000b  ;clear fsw1 interrupt flag
;      pop   ale
;      rete
;*****
;*
;*      clock timer 32hz (/irq1)
;*
;*****
clock32_intr:
;
;      push  ale
;
;      clock timer 32hz interrupt processing
;
;      and   [br:low intr_fac0],#00001000b  ;clear ftm32 interrupt flag
;      pop   ale
;      rete

```

(4)

(4)

(4)

(4)

(4)

(4)

## Source List

```

;*****
;*
;*      clock timer 8hz (/irq1)
;*
;*****
clock8_intr:
    push    ale
;
;      clock timer 8hz interrupt processing
;
    and     [br:low intr_fac0],#00000100b    ;clear ftm8 interrupt flag
    pop     ale
    rete
;*****
;*
;*      clock timer 2hz (/irq1)
;*
;*****
clock2_intr:
    push    ale
;
;      clock timer 2hz interrupt processing
;
    and     [br:low intr_fac0],#00000010b    ;clear ftm2 interrupt flag
    pop     ale
    rete
;*****
;*
;*      clock timer 1hz (/irq1)
;*
;*****
clock1_intr:
    push    ale
;
;      clock timer 1hz interrupt processing
;
    and     [br:low intr_fac0],#00000001b    ;clear ftm1 interrupt flag
    pop     ale
    rete
;
    end

```

(4)

(4)

(4)

# 18 EXPANDED MODE

## Specifications

### Memory access in expanded mode

- (1) **common, common\_sub, ex\_sub: Access for program memory outside logical space**  
Branches to a bank outside logical space by setting NB register.
- (2) **ex\_ram, move\_data: Data block transfer between pages**  
By setting expand page register, copies data (64K bytes) in page 1 to page 2. (Register indirect addressing)
- (3) **ex\_access: Access for data outside page**  
Accesses a data memory area outside of the current page using expand page register.

## Flowchart

### (1) Access for program memory outside logical space

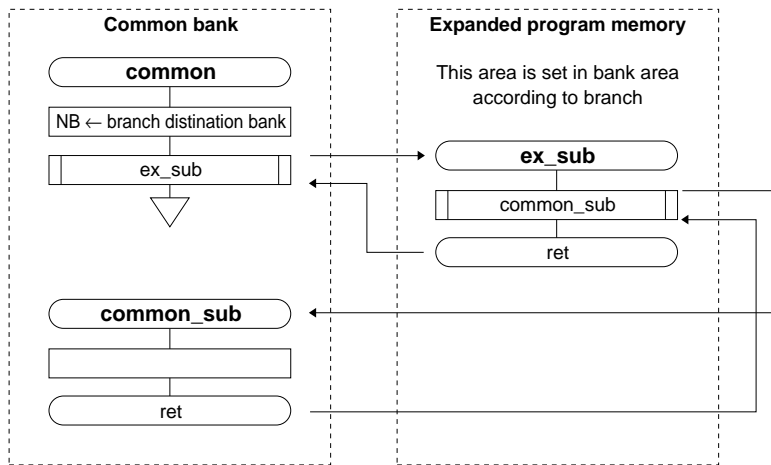

### (2) Data block transfer between pages

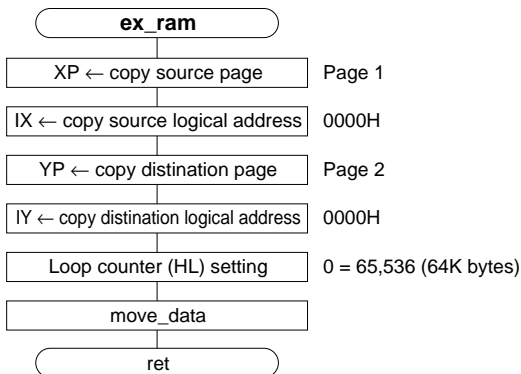

### (3) Access for data outside page

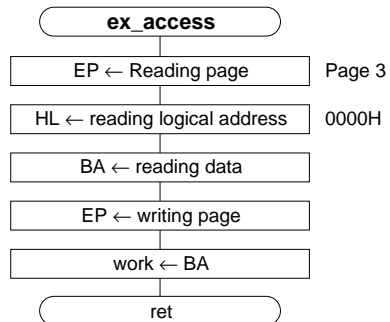

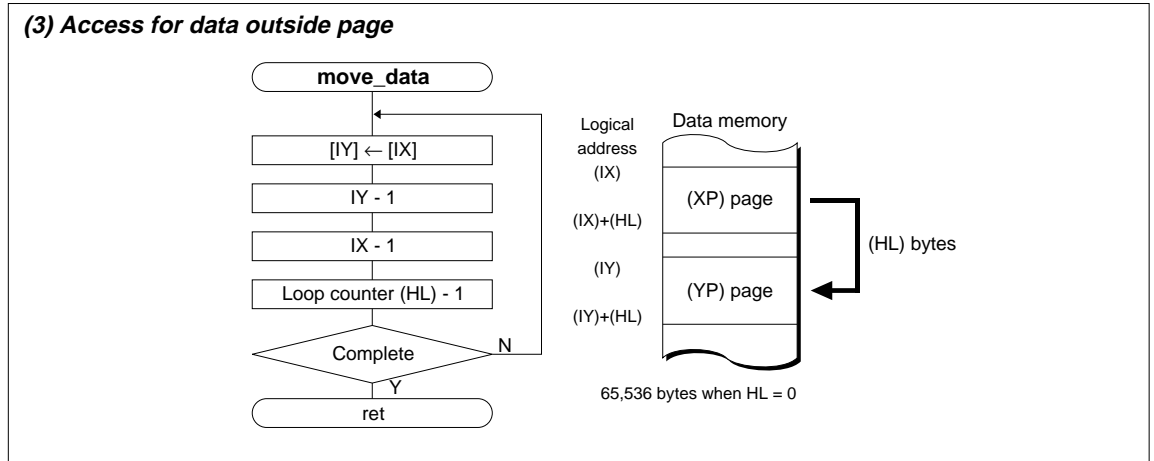
**Flowchart****Notes**

- (1) "boc" is the unary operator which calculates a bank value from the physical address.  
"loc" is the unary operator which calculates a logical address in bank from the physical address.
- (2) "pod" is the unary operator which calculates a page value from the physical address.  
"lod" is the unary operator which calculates a logical address in page from the physical address.

**Source List**

```

public      common,common_sub
public      ex_sub

(1) Access for program memory outside logical space
code
;
;*****
;*
;*      common area (bank0 = 000000h -> 007fffh) example
;*
;*****
common:
;
;      ld      nb,#boc ex_sub          ;set new bank (external area)
;      carl   ex_sub                  ;external bank sub routine call ***
;
;*****
;*
;*      common sub-routine
;*
;*****
common_sub:
;
;      ret
;*****
;*
;*      external area (bank1 -> 15 = 008000h -> 07ffffh) example
;*
;*****
ex_sub:
;
;      carl   common_sub              ;common bank sub routine call ***
;
;      ret
;
;      end
  
```

(1)



Source List

```

;
src_data      equ    10000h          ;source data (page1=010000h -> 01ffffh)
dst_data      equ    20000h          ;destination data (page2=020000h -> 02ffffh)
;
ex_work       equ    30000h          ;external work area
;
work:         dw     [1]
              code
;

```

**(2) Data block transfer between pages**

```

;*****
;*
;*      external ram page control
;*
;*
;*****
ex_ram:
    ld     xp,#pod src_data          ;source data page address
    ld     ix,#lod src_data          ;source data logical top address
    ld     yp,#pod dst_data          ;destination data page address
    ld     iy,#lod dst_data          ;destination data logical top address
    ld     hl,#0                      ;0 = 65,536 (64k byte)
    carl  move_data
    ret
;*****
;*
;*      move block data
;*
;*
;*****
move_data:
    ld     [iy],[ix]
    inc   iy
    inc   ix
    dec   hl
    jrs   nz,move_data
;
    ret

```

(2)

**(3) Access for data outside page**

```

;*****
;*
;*      external page data read and write
;*
;*
;*****
ex_access:
    ld     ep,#pod ex_work
    ld     hl,#lod ex_work
    ld     ba,[hl]
    ld     ep,#pod work
    ld     [lod work],ba
    ret
end

```

(3)



APPENDIX A TABLE OF INPUT/OUTPUT PORT TERMINALS

CPU mode	Terminal configuration depending on model	Input port terminals							Output port terminals							I/O port terminals													
		K00-07	K10	K11	R00-07	R10-17	R20-22	R23	R24	R25	R26	R27	R30	R31	R32	R33	R34	R35-37	R50	R51	P00-07	P10	P11	P12	P13	P14	P15	P16	P17
MPU	E0C88348	↑	↑	↑	↑	↑	↑	↑	↑	↑	↑	↑	↑	↑	↑	↑	↑	↑	↑	↑	↑	↑	↑	↑	↑	↑	↑	↑	
	E0C88317	↑	↑	↑	↑	↑	↑	↑	↑	↑	↑	↑	↑	↑	↑	↑	↑	↑	↑	↑	↑	↑	↑	↑	↑	↑	↑	↑	
	E0C88316	↑	↑	↑	↑	↑	↑	↑	↑	↑	↑	↑	↑	↑	↑	↑	↑	↑	↑	↑	↑	↑	↑	↑	↑	↑	↑	↑	
	E0C88308	↑	↑	↑	↑	↑	↑	↑	↑	↑	↑	↑	↑	↑	↑	↑	↑	↑	↑	↑	↑	↑	↑	↑	↑	↑	↑	↑	
	Special output	K00-07	K10	K11	R00-07	R10-17	R20-22	R23	R24	R25	R26	R27	R30	R31	R32	R33	R34	R35-37	R50	R51	P00-07	P10	P11	P12	P13	P14	P15	P16	P17
	(No special output)	K00-07	K10	K11	R00-07	R10-17	R20-22	R23	R24	R25	R26	R27	R30	R31	R32	R33	R34	R35-37	R50	R51	P00-07	P10	P11	P12	P13	P14	P15	P16	P17
	CE0 output	↑	↑	↑	↑	↑	↑	↑	↑	↑	↑	↑	↑	↑	↑	↑	↑	↑	↑	↑	↑	↑	↑	↑	↑	↑	↑	↑	
	CE1 output	↑	↑	↑	↑	↑	↑	↑	↑	↑	↑	↑	↑	↑	↑	↑	↑	↑	↑	↑	↑	↑	↑	↑	↑	↑	↑	↑	
	CE2 output	↑	↑	↑	↑	↑	↑	↑	↑	↑	↑	↑	↑	↑	↑	↑	↑	↑	↑	↑	↑	↑	↑	↑	↑	↑	↑	↑	
	CE3 output	↑	↑	↑	↑	↑	↑	↑	↑	↑	↑	↑	↑	↑	↑	↑	↑	↑	↑	↑	↑	↑	↑	↑	↑	↑	↑	↑	
Bus release	↑	↑	↑	↑	↑	↑	↑	↑	↑	↑	↑	↑	↑	↑	↑	↑	↑	↑	↑	↑	↑	↑	↑	↑	↑	↑	↑		
Serial interface	↑	↑	↑	↑	↑	↑	↑	↑	↑	↑	↑	↑	↑	↑	↑	↑	↑	↑	↑	↑	↑	↑	↑	↑	↑	↑	↑		
Comparator 0	↑	↑	↑	↑	↑	↑	↑	↑	↑	↑	↑	↑	↑	↑	↑	↑	↑	↑	↑	↑	↑	↑	↑	↑	↑	↑	↑		
Comparator 1	↑	↑	↑	↑	↑	↑	↑	↑	↑	↑	↑	↑	↑	↑	↑	↑	↑	↑	↑	↑	↑	↑	↑	↑	↑	↑	↑		
CL output	↑	↑	↑	↑	↑	↑	↑	↑	↑	↑	↑	↑	↑	↑	↑	↑	↑	↑	↑	↑	↑	↑	↑	↑	↑	↑	↑		
FR output	↑	↑	↑	↑	↑	↑	↑	↑	↑	↑	↑	↑	↑	↑	↑	↑	↑	↑	↑	↑	↑	↑	↑	↑	↑	↑	↑		
TOUT output	↑	↑	↑	↑	↑	↑	↑	↑	↑	↑	↑	↑	↑	↑	↑	↑	↑	↑	↑	↑	↑	↑	↑	↑	↑	↑	↑		
FOUT output	↑	↑	↑	↑	↑	↑	↑	↑	↑	↑	↑	↑	↑	↑	↑	↑	↑	↑	↑	↑	↑	↑	↑	↑	↑	↑	↑		
BZ output	↑	↑	↑	↑	↑	↑	↑	↑	↑	↑	↑	↑	↑	↑	↑	↑	↑	↑	↑	↑	↑	↑	↑	↑	↑	↑	↑		
Expanded 512K (MIN & MAX)	(No special output)	K00-07	K10	K11	R00-07	R10-17	R20-22	R23	R24	R25	R26	R27	R30	R31	R32	R33	R34	R35-37	R50	R51	P00-07	P10	P11	P12	P13	P14	P15	P16	P17
	CE0 output	↑	↑	↑	↑	↑	↑	↑	↑	↑	↑	↑	↑	↑	↑	↑	↑	↑	↑	↑	↑	↑	↑	↑	↑	↑	↑	↑	
	CE1 output	↑	↑	↑	↑	↑	↑	↑	↑	↑	↑	↑	↑	↑	↑	↑	↑	↑	↑	↑	↑	↑	↑	↑	↑	↑	↑	↑	
	CE2 output	↑	↑	↑	↑	↑	↑	↑	↑	↑	↑	↑	↑	↑	↑	↑	↑	↑	↑	↑	↑	↑	↑	↑	↑	↑	↑	↑	
	CE3 output	↑	↑	↑	↑	↑	↑	↑	↑	↑	↑	↑	↑	↑	↑	↑	↑	↑	↑	↑	↑	↑	↑	↑	↑	↑	↑	↑	
	Bus release	↑	↑	↑	↑	↑	↑	↑	↑	↑	↑	↑	↑	↑	↑	↑	↑	↑	↑	↑	↑	↑	↑	↑	↑	↑	↑	↑	
	Serial interface	↑	↑	↑	↑	↑	↑	↑	↑	↑	↑	↑	↑	↑	↑	↑	↑	↑	↑	↑	↑	↑	↑	↑	↑	↑	↑	↑	
	Comparator 0	↑	↑	↑	↑	↑	↑	↑	↑	↑	↑	↑	↑	↑	↑	↑	↑	↑	↑	↑	↑	↑	↑	↑	↑	↑	↑	↑	
	Comparator 1	↑	↑	↑	↑	↑	↑	↑	↑	↑	↑	↑	↑	↑	↑	↑	↑	↑	↑	↑	↑	↑	↑	↑	↑	↑	↑	↑	
	CL output	↑	↑	↑	↑	↑	↑	↑	↑	↑	↑	↑	↑	↑	↑	↑	↑	↑	↑	↑	↑	↑	↑	↑	↑	↑	↑	↑	
FR output	↑	↑	↑	↑	↑	↑	↑	↑	↑	↑	↑	↑	↑	↑	↑	↑	↑	↑	↑	↑	↑	↑	↑	↑	↑	↑	↑		
TOUT output	↑	↑	↑	↑	↑	↑	↑	↑	↑	↑	↑	↑	↑	↑	↑	↑	↑	↑	↑	↑	↑	↑	↑	↑	↑	↑	↑		
FOUT output	↑	↑	↑	↑	↑	↑	↑	↑	↑	↑	↑	↑	↑	↑	↑	↑	↑	↑	↑	↑	↑	↑	↑	↑	↑	↑	↑		
BZ output	↑	↑	↑	↑	↑	↑	↑	↑	↑	↑	↑	↑	↑	↑	↑	↑	↑	↑	↑	↑	↑	↑	↑	↑	↑	↑	↑		

**Note:**

- Blank items will be decided according to other special output settings in the same row.
- In the E0C88308, there are no K11 and R51 terminals and the bus release function cannot be set. Also, R35-R37 terminals have not been set.
- R35-R37 terminals can be used only when the E0C88348/317/316 chip is being shipped.

## Appendix B Instruction List

### 8-bit Transfer Instructions (1/3)

Mnemonic	Machine Code	Operation	Cycle	Byte	SC								Comment	
					I1	I0	U	D	N	V	C	Z		
LD	A,A	40	A←A	1	1	-	-	-	-	-	-	-	-	
	A,B	41	A←B	1	1	-	-	-	-	-	-	-	-	
	A,L	42	A←L	1	1	-	-	-	-	-	-	-	-	
	A,H	43	A←H	1	1	-	-	-	-	-	-	-	-	
	A,BR	CE,C0	A←BR	2	2	-	-	-	-	-	-	-	-	
	A,SC	CE,C1	A←SC	2	2	-	-	-	-	-	-	-	-	
	A,#nn	B0,nn	A←nn	2	2	-	-	-	-	-	-	-	-	
	A,[BR://]	44,//	A←[BR://]	3	2	-	-	-	-	-	-	-	-	
	A,[hh//]	CE,D0,//,hh	A←[hh//]	5	4	-	-	-	-	-	-	-	-	
	A,[HL]	45	A←[HL]	2	1	-	-	-	-	-	-	-	-	
	A,[IX]	46	A←[IX]	2	1	-	-	-	-	-	-	-	-	
	A,[IY]	47	A←[IY]	2	1	-	-	-	-	-	-	-	-	
	A,[IX+dd]	CE,40,dd	A←[IX+dd]	4	3	-	-	-	-	-	-	-	-	
	A,[IY+dd]	CE,41,dd	A←[IY+dd]	4	3	-	-	-	-	-	-	-	-	
	A,[IX+L]	CE,42	A←[IX+L]	4	2	-	-	-	-	-	-	-	-	
	A,[IY+L]	CE,43	A←[IY+L]	4	2	-	-	-	-	-	-	-	-	
	A,NB	CE,C8	A←NB	2	2	-	-	-	-	-	-	-	-	MODEL2/3 only
A,EP	CE,C9	A←EP	2	2	-	-	-	-	-	-	-	-		
A,XP	CE,CA	A←XP	2	2	-	-	-	-	-	-	-	-		
A,YP	CE,CB	A←YP	2	2	-	-	-	-	-	-	-	-		
LD	B,A	48	B←A	1	1	-	-	-	-	-	-	-	-	
	B,B	49	B←B	1	1	-	-	-	-	-	-	-	-	
	B,L	4A	B←L	1	1	-	-	-	-	-	-	-	-	
	B,H	4B	B←H	1	1	-	-	-	-	-	-	-	-	
	B,#nn	B1,nn	B←nn	2	2	-	-	-	-	-	-	-	-	
	B,[BR://]	4C,//	B←[BR://]	3	2	-	-	-	-	-	-	-	-	
	B,[hh//]	CE,D1,//,hh	B←[hh//]	5	4	-	-	-	-	-	-	-	-	
	B,[HL]	4D	B←[HL]	2	1	-	-	-	-	-	-	-	-	
	B,[IX]	4E	B←[IX]	2	1	-	-	-	-	-	-	-	-	
	B,[IY]	4F	B←[IY]	2	1	-	-	-	-	-	-	-	-	
	B,[IX+dd]	CE,48,dd	B←[IX+dd]	4	3	-	-	-	-	-	-	-	-	
	B,[IY+dd]	CE,49,dd	B←[IY+dd]	4	3	-	-	-	-	-	-	-	-	
B,[IX+L]	CE,4A	B←[IX+L]	4	2	-	-	-	-	-	-	-	-		
B,[IY+L]	CE,4B	B←[IY+L]	4	2	-	-	-	-	-	-	-	-		
LD	L,A	50	L←A	1	1	-	-	-	-	-	-	-	-	
	L,B	51	L←B	1	1	-	-	-	-	-	-	-	-	
	L,L	52	L←L	1	1	-	-	-	-	-	-	-	-	
	L,H	53	L←H	1	1	-	-	-	-	-	-	-	-	
	L,#nn	B2,nn	L←nn	2	2	-	-	-	-	-	-	-	-	
	L,[BR://]	54,//	L←[BR://]	3	2	-	-	-	-	-	-	-	-	
	L,[hh//]	CE,D2,//,hh	L←[hh//]	5	4	-	-	-	-	-	-	-	-	
	L,[HL]	55	L←[HL]	2	1	-	-	-	-	-	-	-	-	
	L,[IX]	56	L←[IX]	2	1	-	-	-	-	-	-	-	-	
	L,[IY]	57	L←[IY]	2	1	-	-	-	-	-	-	-	-	
	L,[IX+dd]	CE,50,dd	L←[IX+dd]	4	3	-	-	-	-	-	-	-	-	
	L,[IY+dd]	CE,51,dd	L←[IY+dd]	4	3	-	-	-	-	-	-	-	-	
	L,[IX+L]	CE,52	L←[IX+L]	4	2	-	-	-	-	-	-	-	-	
	L,[IY+L]	CE,53	L←[IY+L]	4	2	-	-	-	-	-	-	-	-	

\* New code bank register NB and expand page registers EP/XP/YP are set only for MODEL2/3. In MODEL0/1, instructions that access these registers cannot be used.

8-bit Transfer Instructions (2/3)

Mnemonic	Machine Code	Operation	Cycle	Byte	SC							Comment		
					I1	I0	U	D	N	V	C		Z	
LD	H,A	58	H←A	1	1	-	-	-	-	-	-	-	-	
	H,B	59	H←B	1	1	-	-	-	-	-	-	-	-	
	H,L	5A	H←L	1	1	-	-	-	-	-	-	-	-	
	H,H	5B	H←H	1	1	-	-	-	-	-	-	-	-	
	H,#nn	B3,nn	H←nn	2	2	-	-	-	-	-	-	-	-	
	H,[BR://]	5C,//	H←[BR://]	3	2	-	-	-	-	-	-	-	-	
	H,[hh//]	CE,D3,//,hh	H←[hh//]	5	4	-	-	-	-	-	-	-	-	
	H,[HL]	5D	H←[HL]	2	1	-	-	-	-	-	-	-	-	
	H,[IX]	5E	H←[IX]	2	1	-	-	-	-	-	-	-	-	
	H,[IY]	5F	H←[IY]	2	1	-	-	-	-	-	-	-	-	
	H,[IX+dd]	CE,58,dd	H←[IX+dd]	4	3	-	-	-	-	-	-	-	-	
	H,[IY+dd]	CE,59,dd	H←[IY+dd]	4	3	-	-	-	-	-	-	-	-	
	H,[IX+L]	CE,5A	H←[IX+L]	4	2	-	-	-	-	-	-	-	-	
	H,[IY+L]	CE,5B	H←[IY+L]	4	2	-	-	-	-	-	-	-	-	
LD	BR,A	CE,C2	BR←A	2	2	-	-	-	-	-	-	-	-	
	BR,#hh	B4,hh	BR←hh	2	2	-	-	-	-	-	-	-	-	
LD	SC,A	CE,C3	SC←A	3	2	↑	↑	↑	↑	↑	↑	↑	↑	
	SC,#nn	9F,nn	SC←nn	3	2	↑	↑	↑	↑	↑	↑	↑	↑	
LD	[BR://],A	78,//	[BR://]←A	3	2	-	-	-	-	-	-	-	-	
	[BR://],B	79,//	[BR://]←B	3	2	-	-	-	-	-	-	-	-	
	[BR://],L	7A,//	[BR://]←L	3	2	-	-	-	-	-	-	-	-	
	[BR://],H	7B,//	[BR://]←H	3	2	-	-	-	-	-	-	-	-	
	[BR://],#nn	DD,//,nn	[BR://]←nn	4	3	-	-	-	-	-	-	-	-	
	[BR://],[HL]	7D,//	[BR://]←[HL]	4	2	-	-	-	-	-	-	-	-	
	[BR://],[IX]	7E,//	[BR://]←[IX]	4	2	-	-	-	-	-	-	-	-	
[BR://],[IY]	7F,//	[BR://]←[IY]	4	2	-	-	-	-	-	-	-	-		
LD	[hh//],A	CE,D4,//,hh	[hh//]←A	5	4	-	-	-	-	-	-	-	-	
	[hh//],B	CE,D5,//,hh	[hh//]←B	5	4	-	-	-	-	-	-	-	-	
	[hh//],L	CE,D6,//,hh	[hh//]←L	5	4	-	-	-	-	-	-	-	-	
	[hh//],H	CE,D7,//,hh	[hh//]←H	5	4	-	-	-	-	-	-	-	-	
LD	[HL],A	68	[HL]←A	2	1	-	-	-	-	-	-	-	-	
	[HL],B	69	[HL]←B	2	1	-	-	-	-	-	-	-	-	
	[HL],L	6A	[HL]←L	2	1	-	-	-	-	-	-	-	-	
	[HL],H	6B	[HL]←H	2	1	-	-	-	-	-	-	-	-	
	[HL],#nn	B5,nn	[HL]←nn	3	2	-	-	-	-	-	-	-	-	
	[HL],[BR://]	6C,//	[HL]←[BR://]	4	2	-	-	-	-	-	-	-	-	
	[HL],[HL]	6D	[HL]←[HL]	3	1	-	-	-	-	-	-	-	-	
	[HL],[IX]	6E	[HL]←[IX]	3	1	-	-	-	-	-	-	-	-	
	[HL],[IY]	6F	[HL]←[IY]	3	1	-	-	-	-	-	-	-	-	
	[HL],[IX+dd]	CE,60,dd	[HL]←[IX+dd]	5	3	-	-	-	-	-	-	-	-	
	[HL],[IY+dd]	CE,61,dd	[HL]←[IY+dd]	5	3	-	-	-	-	-	-	-	-	
	[HL],[IX+L]	CE,62	[HL]←[IX+L]	5	2	-	-	-	-	-	-	-	-	
	[HL],[IY+L]	CE,63	[HL]←[IY+L]	5	2	-	-	-	-	-	-	-	-	
LD	[IX],A	60	[IX]←A	2	1	-	-	-	-	-	-	-	-	
	[IX],B	61	[IX]←B	2	1	-	-	-	-	-	-	-	-	
	[IX],L	62	[IX]←L	2	1	-	-	-	-	-	-	-	-	
	[IX],H	63	[IX]←H	2	1	-	-	-	-	-	-	-	-	
	[IX],#nn	B6,nn	[IX]←nn	3	2	-	-	-	-	-	-	-	-	

## 8-bit Transfer Instructions (3/3)

Mnemonic	Machine Code	Operation	Cycle	Byte	SC							Comment			
					I1	I0	U	D	N	V	C		Z		
LD	[IX],[BR://]	64,II	[IX]←[BR://]	4	2	-	-	-	-	-	-	-	-		
	[IX],[HL]	65	[IX]←[HL]	3	1	-	-	-	-	-	-	-	-		
	[IX],[IX]	66	[IX]←[IX]	3	1	-	-	-	-	-	-	-	-		
	[IX],[IY]	67	[IX]←[IY]	3	1	-	-	-	-	-	-	-	-		
	[IX],[IX+dd]	CE,68,dd	[IX]←[IX+dd]	5	3	-	-	-	-	-	-	-	-		
	[IX],[IY+dd]	CE,69,dd	[IX]←[IY+dd]	5	3	-	-	-	-	-	-	-	-		
	[IX],[IX+L]	CE,6A	[IX]←[IX+L]	5	2	-	-	-	-	-	-	-	-		
	[IX],[IY+L]	CE,6B	[IX]←[IY+L]	5	2	-	-	-	-	-	-	-	-		
LD	[IY],A	70	[IY]←A	2	1	-	-	-	-	-	-	-	-		
	[IY],B	71	[IY]←B	2	1	-	-	-	-	-	-	-	-		
	[IY],L	72	[IY]←L	2	1	-	-	-	-	-	-	-	-		
	[IY],H	73	[IY]←H	2	1	-	-	-	-	-	-	-	-		
	[IY],#nn	B7,nn	[IY]←nn	3	2	-	-	-	-	-	-	-	-		
	[IY],[BR://]	74,II	[IY]←[BR://]	4	2	-	-	-	-	-	-	-	-		
	[IY],[HL]	75	[IY]←[HL]	3	1	-	-	-	-	-	-	-	-		
	[IY],[IX]	76	[IY]←[IX]	3	1	-	-	-	-	-	-	-	-		
	[IY],[IY]	77	[IY]←[IY]	3	1	-	-	-	-	-	-	-	-		
	[IY],[IX+dd]	CE,78,dd	[IY]←[IX+dd]	5	3	-	-	-	-	-	-	-	-		
	[IY],[IY+dd]	CE,79,dd	[IY]←[IY+dd]	5	3	-	-	-	-	-	-	-	-		
	[IY],[IX+L]	CE,7A	[IY]←[IX+L]	5	2	-	-	-	-	-	-	-	-		
[IY],[IY+L]	CE,7B	[IY]←[IY+L]	5	2	-	-	-	-	-	-	-	-			
LD	[IX+dd],A	CE,44,dd	[IX+dd]←A	4	3	-	-	-	-	-	-	-	-		
	[IX+dd],B	CE,4C,dd	[IX+dd]←B	4	3	-	-	-	-	-	-	-	-		
	[IX+dd],L	CE,54,dd	[IX+dd]←L	4	3	-	-	-	-	-	-	-	-		
	[IX+dd],H	CE,5C,dd	[IX+dd]←H	4	3	-	-	-	-	-	-	-	-		
LD	[IY+dd],A	CE,45,dd	[IY+dd]←A	4	3	-	-	-	-	-	-	-	-		
	[IY+dd],B	CE,4D,dd	[IY+dd]←B	4	3	-	-	-	-	-	-	-	-		
	[IY+dd],L	CE,55,dd	[IY+dd]←L	4	3	-	-	-	-	-	-	-	-		
	[IY+dd],H	CE,5D,dd	[IY+dd]←H	4	3	-	-	-	-	-	-	-	-		
LD	[IX+L],A	CE,46	[IX+L]←A	4	2	-	-	-	-	-	-	-	-		
	[IX+L],B	CE,4E	[IX+L]←B	4	2	-	-	-	-	-	-	-	-		
	[IX+L],L	CE,56	[IX+L]←L	4	2	-	-	-	-	-	-	-	-		
	[IX+L],H	CE,5E	[IX+L]←H	4	2	-	-	-	-	-	-	-	-		
LD	[IY+L],A	CE,47	[IY+L]←A	4	2	-	-	-	-	-	-	-	-		
	[IY+L],B	CE,4F	[IY+L]←B	4	2	-	-	-	-	-	-	-	-		
	[IY+L],L	CE,57	[IY+L]←L	4	2	-	-	-	-	-	-	-	-		
	[IY+L],H	CE,5F	[IY+L]←H	4	2	-	-	-	-	-	-	-	-		
LD	NB,A	CE,CC	NB←A	3	2	-	-	-	-	-	-	-	-	MODEL2/3 only	
	NB,#bb	CE,C4,bb	NB←bb	4	3	-	-	-	-	-	-	-	-		
LD	EP,A	CE,CD	EP←A	2	2	-	-	-	-	-	-	-	-		
	EP,#pp	CE,C5,pp	EP←pp	3	3	-	-	-	-	-	-	-	-		
LD	XP,A	CE,CE	XP←A	2	2	-	-	-	-	-	-	-	-		
	XP,#pp	CE,C6,pp	XP←pp	3	3	-	-	-	-	-	-	-	-		
LD	YP,A	CE,CF	YP←A	2	2	-	-	-	-	-	-	-	-		
	YP,#pp	CE,C7,pp	YP←pp	3	3	-	-	-	-	-	-	-	-		
EX	A,B	CC	A↔B	2	1	-	-	-	-	-	-	-	-		
	A,[HL]	CD	A↔[HL]	3	1	-	-	-	-	-	-	-	-		
SWAP	A	F6	A(H)↔A(L)	2	1	-	-	-	-	-	-	-	-		
	[HL]	F7	[HL](H)↔[HL](L)	3	1	-	-	-	-	-	-	-	-		

\* New code bank register NB and expand page registers EP/XP/YP are set only for MODEL2/3. In MODEL0/1, instructions that access these registers cannot be used.

### 16-bit Transfer Instructions (1/2)

Mnemonic	Machine Code	Operation	Cycle	Byte	SC							Comment		
					11	10	U	D	N	V	C		Z	
LD	BA,BA	CF,E0	BA←BA	2	2	-	-	-	-	-	-	-	-	
	BA,HL	CF,E1	BA←HL	2	2	-	-	-	-	-	-	-	-	
	BA,IX	CF,E2	BA←IX	2	2	-	-	-	-	-	-	-	-	
	BA,IY	CF,E3	BA←IY	2	2	-	-	-	-	-	-	-	-	
	BA,SP	CF,F8	BA←SP	2	2	-	-	-	-	-	-	-	-	
	BA,PC	CF,F9	BA←PC+2	2	2	-	-	-	-	-	-	-	-	
	BA,#mmnn	C4,nn,mm	BA←mmnn	3	3	-	-	-	-	-	-	-	-	
	BA,[hh//]	B8,//,hh	A←[hh//], B←[hh//+1]	5	3	-	-	-	-	-	-	-	-	
	BA,[HL]	CF,C0	A←[HL], B←[HL+1]	5	2	-	-	-	-	-	-	-	-	
	BA,[IX]	CF,D0	A←[IX], B←[IX+1]	5	2	-	-	-	-	-	-	-	-	
BA,[IY]	CF,D8	A←[IY], B←[IY+1]	5	2	-	-	-	-	-	-	-	-		
BA,[SP+dd]	CF,70,dd	A←[SP+dd], B←[SP+dd+1]	6	3	-	-	-	-	-	-	-	-		
LD	HL,BA	CF,E4	HL←BA	2	2	-	-	-	-	-	-	-	-	
	HL,HL	CF,E5	HL←HL	2	2	-	-	-	-	-	-	-	-	
	HL,IX	CF,E6	HL←IX	2	2	-	-	-	-	-	-	-	-	
	HL,IY	CF,E7	HL←IY	2	2	-	-	-	-	-	-	-	-	
	HL,SP	CF,F4	HL←SP	2	2	-	-	-	-	-	-	-	-	
	HL,PC	CF,F5	HL←PC+2	2	2	-	-	-	-	-	-	-	-	
	HL,#mmnn	C5,nn,mm	HL←mmnn	3	3	-	-	-	-	-	-	-	-	
	HL,[hh//]	B9,//,hh	L←[hh//], H←[hh//+1]	5	3	-	-	-	-	-	-	-	-	
	HL,[HL]	CF,C1	L←[HL], H←[HL+1]	5	2	-	-	-	-	-	-	-	-	
	HL,[IX]	CF,D1	L←[IX], H←[IX+1]	5	2	-	-	-	-	-	-	-	-	
	HL,[IY]	CF,D9	L←[IY], H←[IY+1]	5	2	-	-	-	-	-	-	-	-	
	HL,[SP+dd]	CF,71,dd	L←[SP+dd], H←[SP+dd+1]	6	3	-	-	-	-	-	-	-	-	
LD	IX,BA	CF,E8	IX←BA	2	2	-	-	-	-	-	-	-	-	
	IX,HL	CF,E9	IX←HL	2	2	-	-	-	-	-	-	-	-	
	IX,IX	CF,EA	IX←IX	2	2	-	-	-	-	-	-	-	-	
	IX,IY	CF,EB	IX←IY	2	2	-	-	-	-	-	-	-	-	
	IX,SP	CF,FA	IX←SP	2	2	-	-	-	-	-	-	-	-	
	IX,#mmnn	C6,nn,mm	IX←mmnn	3	3	-	-	-	-	-	-	-	-	
	IX,[hh//]	BA,//,hh	IX(L)←[hh//], IX(H)←[hh//+1]	5	3	-	-	-	-	-	-	-	-	
	IX,[HL]	CF,C2	IX(L)←[HL], IX(H)←[HL+1]	5	2	-	-	-	-	-	-	-	-	
	IX,[IX]	CF,D2	IX(L)←[IX], IX(H)←[IX+1]	5	2	-	-	-	-	-	-	-	-	
	IX,[IY]	CF,DA	IX(L)←[IY], IX(H)←[IY+1]	5	2	-	-	-	-	-	-	-	-	
IX,[SP+dd]	CF,72,dd	IX(L)←[SP+dd], IX(H)←[SP+dd+1]	6	3	-	-	-	-	-	-	-	-		
LD	IY,BA	CF,EC	IY←BA	2	2	-	-	-	-	-	-	-	-	
	IY,HL	CF,ED	IY←HL	2	2	-	-	-	-	-	-	-	-	
	IY,IX	CF,EE	IY←IX	2	2	-	-	-	-	-	-	-	-	
	IY,IY	CF,EF	IY←IY	2	2	-	-	-	-	-	-	-	-	
	IY,SP	CF,FE	IY←SP	2	2	-	-	-	-	-	-	-	-	
	IY,#mmnn	C7,nn,mm	IY←mmnn	3	3	-	-	-	-	-	-	-	-	
	IY,[hh//]	BB,//,hh	IY(L)←[hh//], IY(H)←[hh//+1]	5	3	-	-	-	-	-	-	-	-	
	IY,[HL]	CF,C3	IY(L)←[HL], IY(H)←[HL+1]	5	2	-	-	-	-	-	-	-	-	
	IY,[IX]	CF,D3	IY(L)←[IX], IY(H)←[IX+1]	5	2	-	-	-	-	-	-	-	-	
	IY,[IY]	CF,DB	IY(L)←[IY], IY(H)←[IY+1]	5	2	-	-	-	-	-	-	-	-	
	IY,[SP+dd]	CF,73,dd	IY(L)←[SP+dd], IY(H)←[SP+dd+1]	6	3	-	-	-	-	-	-	-	-	

## 16-bit Transfer Instructions (2/2)

Mnemonic	Machine Code	Operation	Cycle	Byte	SC								Comment	
					I1	I0	U	D	N	V	C	Z		
LD	SP,BA	CF,F0	SP←BA	2	2	-	-	-	-	-	-	-	-	
	SP,[hh/l]	CF,78,ll,hh	SP(L)←[hh/l], SP(H)←[hh/l+1]	6	4	-	-	-	-	-	-	-	-	
	SP,HL	CF,F1	SP←HL	2	2	-	-	-	-	-	-	-	-	
	SP,IX	CF,F2	SP←IX	2	2	-	-	-	-	-	-	-	-	
	SP,IY	CF,F3	SP←IY	2	2	-	-	-	-	-	-	-	-	
	SP,#mmnn	CF,6E,nn,mm	SP←mmnn	4	4	-	-	-	-	-	-	-	-	
LD	[hh/l],BA	BC,ll,hh	[hh/l]←A, [hh/l+1]←B	5	3	-	-	-	-	-	-	-	-	
	[hh/l],HL	BD,ll,hh	[hh/l]←L, [hh/l+1]←H	5	3	-	-	-	-	-	-	-	-	
	[hh/l],IX	BE,ll,hh	[hh/l]←IX(L), [hh/l+1]←IX(H)	5	3	-	-	-	-	-	-	-	-	
	[hh/l],IY	BF,ll,hh	[hh/l]←IY(L), [hh/l+1]←IY(H)	5	3	-	-	-	-	-	-	-	-	
	[hh/l],SP	CF,7C,ll,hh	[hh/l]←SP(L), [hh/l+1]←SP(H)	6	4	-	-	-	-	-	-	-	-	
LD	[HL],BA	CF,C4	[HL]←A, [HL+1]←B	5	2	-	-	-	-	-	-	-	-	
	[HL],HL	CF,C5	[HL]←L, [HL+1]←H	5	2	-	-	-	-	-	-	-	-	
	[HL],IX	CF,C6	[HL]←IX(L), [HL+1]←IX(H)	5	2	-	-	-	-	-	-	-	-	
	[HL],IY	CF,C7	[HL]←IY(L), [HL+1]←IY(H)	5	2	-	-	-	-	-	-	-	-	
LD	[IX],BA	CF,D4	[IX]←A, [IX+1]←B	5	2	-	-	-	-	-	-	-	-	
	[IX],HL	CF,D5	[IX]←L, [IX+1]←H	5	2	-	-	-	-	-	-	-	-	
	[IX],IX	CF,D6	[IX]←IX(L), [IX+1]←IX(H)	5	2	-	-	-	-	-	-	-	-	
	[IX],IY	CF,D7	[IX]←IY(L), [IX+1]←IY(H)	5	2	-	-	-	-	-	-	-	-	
LD	[IY],BA	CF,DC	[IY]←A, [IY+1]←B	5	2	-	-	-	-	-	-	-	-	
	[IY],HL	CF,DD	[IY]←L, [IY+1]←H	5	2	-	-	-	-	-	-	-	-	
	[IY],IX	CF,DE	[IY]←IX(L), [IY+1]←IX(H)	5	2	-	-	-	-	-	-	-	-	
	[IY],IY	CF,DF	[IY]←IY(L), [IY+1]←IY(H)	5	2	-	-	-	-	-	-	-	-	
LD	[SP+dd],BA	CF,74,dd	[SP+dd]←A, [SP+dd+1]←B	6	3	-	-	-	-	-	-	-	-	
	[SP+dd],HL	CF,75,dd	[SP+dd]←L, [SP+dd+1]←H	6	3	-	-	-	-	-	-	-	-	
	[SP+dd],IX	CF,76,dd	[SP+dd]←IX(L), [SP+dd+1]←IX(H)	6	3	-	-	-	-	-	-	-	-	
	[SP+dd],IY	CF,77,dd	[SP+dd]←IY(L), [SP+dd+1]←IY(H)	6	3	-	-	-	-	-	-	-	-	
EX	BA,HL	C8	BA↔HL	3	1	-	-	-	-	-	-	-	-	
	BA,IX	C9	BA↔IX	3	1	-	-	-	-	-	-	-	-	
	BA,IY	CA	BA↔IY	3	1	-	-	-	-	-	-	-	-	
	BA,SP	CB	BA↔SP	3	1	-	-	-	-	-	-	-	-	



8-bit Arithmetic and Logic Operation Instructions (1/4)

Mnemonic	Machine Code	Operation	Cycle	Byte	SC								Comment	
					I1	I0	U	D	N	V	C	Z		
ADD	A,A	00	$A \leftarrow A+A$	2	1	-	-	★	★	↓	↓	↓	↓	
	A,B	01	$A \leftarrow A+B$	2	1	-	-	★	★	↓	↓	↓	↓	
	A,#nn	02,nn	$A \leftarrow A+nn$	2	2	-	-	★	★	↓	↓	↓	↓	
	A,[BR://]	04, //	$A \leftarrow A+[BR://]$	3	2	-	-	★	★	↓	↓	↓	↓	
	A,[hh//]	05, //, hh	$A \leftarrow A+[hh//]$	4	3	-	-	★	★	↓	↓	↓	↓	
	A,[HL]	03	$A \leftarrow A+[HL]$	2	1	-	-	★	★	↓	↓	↓	↓	
	A,[IX]	06	$A \leftarrow A+[IX]$	2	1	-	-	★	★	↓	↓	↓	↓	
	A,[IY]	07	$A \leftarrow A+[IY]$	2	1	-	-	★	★	↓	↓	↓	↓	
	A,[IX+dd]	CE,00,dd	$A \leftarrow A+[IX+dd]$	4	3	-	-	★	★	↓	↓	↓	↓	
	A,[IY+dd]	CE,01,dd	$A \leftarrow A+[IY+dd]$	4	3	-	-	★	★	↓	↓	↓	↓	
	A,[IX+L]	CE,02	$A \leftarrow A+[IX+L]$	4	2	-	-	★	★	↓	↓	↓	↓	
	A,[IY+L]	CE,03	$A \leftarrow A+[IY+L]$	4	2	-	-	★	★	↓	↓	↓	↓	
	[HL],A	CE,04	$[HL] \leftarrow [HL]+A$	4	2	-	-	★	★	↓	↓	↓	↓	
	[HL],#nn	CE,05,nn	$[HL] \leftarrow [HL]+nn$	5	3	-	-	★	★	↓	↓	↓	↓	
	[HL],[IX]	CE,06	$[HL] \leftarrow [HL]+[IX]$	5	2	-	-	★	★	↓	↓	↓	↓	
[HL],[IY]	CE,07	$[HL] \leftarrow [HL]+[IY]$	5	2	-	-	★	★	↓	↓	↓	↓		
ADC	A,A	08	$A \leftarrow A+A+C$	2	1	-	-	★	★	↓	↓	↓	↓	
	A,B	09	$A \leftarrow A+B+C$	2	1	-	-	★	★	↓	↓	↓	↓	
	A,#nn	0A,nn	$A \leftarrow A+nn+C$	2	2	-	-	★	★	↓	↓	↓	↓	
	A,[BR://]	0C, //	$A \leftarrow A+[BR://]+C$	3	2	-	-	★	★	↓	↓	↓	↓	
	A,[hh//]	0D, //, hh	$A \leftarrow A+[hh//]+C$	4	3	-	-	★	★	↓	↓	↓	↓	
	A,[HL]	0B	$A \leftarrow A+[HL]+C$	2	1	-	-	★	★	↓	↓	↓	↓	
	A,[IX]	0E	$A \leftarrow A+[IX]+C$	2	1	-	-	★	★	↓	↓	↓	↓	
	A,[IY]	0F	$A \leftarrow A+[IY]+C$	2	1	-	-	★	★	↓	↓	↓	↓	
	A,[IX+dd]	CE,08,dd	$A \leftarrow A+[IX+dd]+C$	4	3	-	-	★	★	↓	↓	↓	↓	
	A,[IY+dd]	CE,09,dd	$A \leftarrow A+[IY+dd]+C$	4	3	-	-	★	★	↓	↓	↓	↓	
	A,[IX+L]	CE,0A	$A \leftarrow A+[IX+L]+C$	4	2	-	-	★	★	↓	↓	↓	↓	
	A,[IY+L]	CE,0B	$A \leftarrow A+[IY+L]+C$	4	2	-	-	★	★	↓	↓	↓	↓	
	[HL],A	CE,0C	$[HL] \leftarrow [HL]+A+C$	4	2	-	-	★	★	↓	↓	↓	↓	
	[HL],#nn	CE,0D,nn	$[HL] \leftarrow [HL]+nn+C$	5	3	-	-	★	★	↓	↓	↓	↓	
	[HL],[IX]	CE,0E	$[HL] \leftarrow [HL]+[IX]+C$	5	2	-	-	★	★	↓	↓	↓	↓	
[HL],[IY]	CE,0F	$[HL] \leftarrow [HL]+[IY]+C$	5	2	-	-	★	★	↓	↓	↓	↓		
SUB	A,A	10	$A \leftarrow A-A$	2	1	-	-	★	★	↓	↓	↓	↓	
	A,B	11	$A \leftarrow A-B$	2	1	-	-	★	★	↓	↓	↓	↓	
	A,#nn	12,nn	$A \leftarrow A-nn$	2	2	-	-	★	★	↓	↓	↓	↓	
	A,[BR://]	14, //	$A \leftarrow A-[BR://]$	3	2	-	-	★	★	↓	↓	↓	↓	
	A,[hh//]	15, //, hh	$A \leftarrow A-[hh//]$	4	3	-	-	★	★	↓	↓	↓	↓	
	A,[HL]	13	$A \leftarrow A-[HL]$	2	1	-	-	★	★	↓	↓	↓	↓	
	A,[IX]	16	$A \leftarrow A-[IX]$	2	1	-	-	★	★	↓	↓	↓	↓	
	A,[IY]	17	$A \leftarrow A-[IY]$	2	1	-	-	★	★	↓	↓	↓	↓	
	A,[IX+dd]	CE,10,dd	$A \leftarrow A-[IX+dd]$	4	3	-	-	★	★	↓	↓	↓	↓	
	A,[IY+dd]	CE,11,dd	$A \leftarrow A-[IY+dd]$	4	3	-	-	★	★	↓	↓	↓	↓	
	A,[IX+L]	CE,12	$A \leftarrow A-[IX+L]$	4	2	-	-	★	★	↓	↓	↓	↓	
	A,[IY+L]	CE,13	$A \leftarrow A-[IY+L]$	4	2	-	-	★	★	↓	↓	↓	↓	
	[HL],A	CE,14	$[HL] \leftarrow [HL]-A$	4	2	-	-	★	★	↓	↓	↓	↓	
	[HL],#nn	CE,15,nn	$[HL] \leftarrow [HL]-nn$	5	3	-	-	★	★	↓	↓	↓	↓	
	[HL],[IX]	CE,16	$[HL] \leftarrow [HL]-[IX]$	5	2	-	-	★	★	↓	↓	↓	↓	
	[HL],[IY]	CE,17	$[HL] \leftarrow [HL]-[IY]$	5	2	-	-	★	★	↓	↓	↓	↓	

## 8-bit Arithmetic and Logic Operation Instructions (2/4)

Mnemonic	Machine Code	Operation	Cycle	Byte	SC								Comment	
					I1	I0	U	D	N	V	C	Z		
SBC	A,A	18	$A \leftarrow A - A - C$	2	1	-	-	★	★	↓	↓	↓	↓	
	A,B	19	$A \leftarrow A - B - C$	2	1	-	-	★	★	↓	↓	↓	↓	
	A,#nn	1A,nn	$A \leftarrow A - nn - C$	2	2	-	-	★	★	↓	↓	↓	↓	
	A,[BR://]	1C,//	$A \leftarrow A - [BR://] - C$	3	2	-	-	★	★	↓	↓	↓	↓	
	A,[hh//]	1D,//,hh	$A \leftarrow A - [hh//] - C$	4	3	-	-	★	★	↓	↓	↓	↓	
	A,[HL]	1B	$A \leftarrow A - [HL] - C$	2	1	-	-	★	★	↓	↓	↓	↓	
	A,[IX]	1E	$A \leftarrow A - [IX] - C$	2	1	-	-	★	★	↓	↓	↓	↓	
	A,[IY]	1F	$A \leftarrow A - [IY] - C$	2	1	-	-	★	★	↓	↓	↓	↓	
	A,[IX+dd]	CE,18,dd	$A \leftarrow A - [IX+dd] - C$	4	3	-	-	★	★	↓	↓	↓	↓	
	A,[IY+dd]	CE,19,dd	$A \leftarrow A - [IY+dd] - C$	4	3	-	-	★	★	↓	↓	↓	↓	
	A,[IX+L]	CE,1A	$A \leftarrow A - [IX+L] - C$	4	2	-	-	★	★	↓	↓	↓	↓	
	A,[IY+L]	CE,1B	$A \leftarrow A - [IY+L] - C$	4	2	-	-	★	★	↓	↓	↓	↓	
	[HL],A	CE,1C	$[HL] \leftarrow [HL] - A - C$	4	2	-	-	★	★	↓	↓	↓	↓	
	[HL],#nn	CE,1D,nn	$[HL] \leftarrow [HL] - nn - C$	5	3	-	-	★	★	↓	↓	↓	↓	
	[HL],[IX]	CE,1E	$[HL] \leftarrow [HL] - [IX] - C$	5	2	-	-	★	★	↓	↓	↓	↓	
[HL],[IY]	CE,1F	$[HL] \leftarrow [HL] - [IY] - C$	5	2	-	-	★	★	↓	↓	↓	↓		
AND	A,A	20	$A \leftarrow A \wedge A$	2	1	-	-	-	-	↓	-	-	↓	
	A,B	21	$A \leftarrow A \wedge B$	2	1	-	-	-	-	↓	-	-	↓	
	A,#nn	22,nn	$A \leftarrow A \wedge nn$	2	2	-	-	-	-	↓	-	-	↓	
	A,[BR://]	24,//	$A \leftarrow A \wedge [BR://]$	3	2	-	-	-	-	↓	-	-	↓	
	A,[hh//]	25,//,hh	$A \leftarrow A \wedge [hh//]$	4	3	-	-	-	-	↓	-	-	↓	
	A,[HL]	23	$A \leftarrow A \wedge [HL]$	2	1	-	-	-	-	↓	-	-	↓	
	A,[IX]	26	$A \leftarrow A \wedge [IX]$	2	1	-	-	-	-	↓	-	-	↓	
	A,[IY]	27	$A \leftarrow A \wedge [IY]$	2	1	-	-	-	-	↓	-	-	↓	
	A,[IX+dd]	CE,20,dd	$A \leftarrow A \wedge [IX+dd]$	4	3	-	-	-	-	↓	-	-	↓	
	A,[IY+dd]	CE,21,dd	$A \leftarrow A \wedge [IY+dd]$	4	3	-	-	-	-	↓	-	-	↓	
	A,[IX+L]	CE,22	$A \leftarrow A \wedge [IX+L]$	4	2	-	-	-	-	↓	-	-	↓	
	A,[IY+L]	CE,23	$A \leftarrow A \wedge [IY+L]$	4	2	-	-	-	-	↓	-	-	↓	
	B,#nn	CE,B0,nn	$B \leftarrow B \wedge nn$	3	3	-	-	-	-	↓	-	-	↓	
	L,#nn	CE,B1,nn	$L \leftarrow L \wedge nn$	3	3	-	-	-	-	↓	-	-	↓	
	H,#nn	CE,B2,nn	$H \leftarrow H \wedge nn$	3	3	-	-	-	-	↓	-	-	↓	
	SC,#nn	9C,nn	$SC \leftarrow SC \wedge nn$	3	2	↓	↓	↓	↓	↓	↓	↓	↓	
	[BR://],#nn	D8,//,nn	$[BR://] \leftarrow [BR://] \wedge nn$	5	3	-	-	-	-	↓	-	-	↓	
	[HL],A	CE,24	$[HL] \leftarrow [HL] \wedge A$	4	2	-	-	-	-	↓	-	-	↓	
	[HL],#nn	CE,25,nn	$[HL] \leftarrow [HL] \wedge nn$	5	3	-	-	-	-	↓	-	-	↓	
	[HL],[IX]	CE,26	$[HL] \leftarrow [HL] \wedge [IX]$	5	2	-	-	-	-	↓	-	-	↓	
[HL],[IY]	CE,27	$[HL] \leftarrow [HL] \wedge [IY]$	5	2	-	-	-	-	↓	-	-	↓		
OR	A,A	28	$A \leftarrow A \vee A$	2	1	-	-	-	-	↓	-	-	↓	
	A,B	29	$A \leftarrow A \vee B$	2	1	-	-	-	-	↓	-	-	↓	
	A,#nn	2A,nn	$A \leftarrow A \vee nn$	2	2	-	-	-	-	↓	-	-	↓	
	A,[BR://]	2C,//	$A \leftarrow A \vee [BR://]$	3	2	-	-	-	-	↓	-	-	↓	
	A,[hh//]	2D,//,hh	$A \leftarrow A \vee [hh//]$	4	3	-	-	-	-	↓	-	-	↓	
	A,[HL]	2B	$A \leftarrow A \vee [HL]$	2	1	-	-	-	-	↓	-	-	↓	
	A,[IX]	2E	$A \leftarrow A \vee [IX]$	2	1	-	-	-	-	↓	-	-	↓	
	A,[IY]	2F	$A \leftarrow A \vee [IY]$	2	1	-	-	-	-	↓	-	-	↓	
	A,[IX+dd]	CE,28,dd	$A \leftarrow A \vee [IX+dd]$	4	3	-	-	-	-	↓	-	-	↓	
	A,[IY+dd]	CE,29,dd	$A \leftarrow A \vee [IY+dd]$	4	3	-	-	-	-	↓	-	-	↓	
	A,[IX+L]	CE,2A	$A \leftarrow A \vee [IX+L]$	4	2	-	-	-	-	↓	-	-	↓	

8-bit Arithmetic and Logic Operation Instructions (3/4)

Mnemonic	Machine Code	Operation	Cycle	Byte	SC								Comment	
					I1	I0	U	D	N	V	C	Z		
OR	A,[IY+L]	CE,2B	$A \leftarrow A \vee [IY+L]$	4	2	-	-	-	-	↓	-	-	↓	
	B,#nn	CE,B4,nn	$B \leftarrow B \vee nn$	3	3	-	-	-	-	↓	-	-	↓	
	L,#nn	CE,B5,nn	$L \leftarrow L \vee nn$	3	3	-	-	-	-	↓	-	-	↓	
	H,#nn	CE,B6,nn	$H \leftarrow H \vee nn$	3	3	-	-	-	-	↓	-	-	↓	
	SC,#nn	9D,nn	$SC \leftarrow SC \vee nn$	3	2	↑	↑	↑	↑	↑	↑	↑	↑	
	[BR:ll],#nn	D9,ll,nn	$[BR:ll] \leftarrow [BR:ll] \vee nn$	5	3	-	-	-	-	↓	-	-	↓	
	[HL],A	CE,2C	$[HL] \leftarrow [HL] \vee A$	4	2	-	-	-	-	↓	-	-	↓	
	[HL],#nn	CE,2D,nn	$[HL] \leftarrow [HL] \vee nn$	5	3	-	-	-	-	↓	-	-	↓	
	[HL],[IX]	CE,2E	$[HL] \leftarrow [HL] \vee [IX]$	5	2	-	-	-	-	↓	-	-	↓	
	[HL],[IY]	CE,2F	$[HL] \leftarrow [HL] \vee [IY]$	5	2	-	-	-	-	↓	-	-	↓	
XOR	A,A	38	$A \leftarrow A \vee A$	2	1	-	-	-	-	↓	-	-	↓	
	A,B	39	$A \leftarrow A \vee B$	2	1	-	-	-	-	↓	-	-	↓	
	A,#nn	3A,nn	$A \leftarrow A \vee nn$	2	2	-	-	-	-	↓	-	-	↓	
	A,[BR:ll]	3C,ll	$A \leftarrow A \vee [BR:ll]$	3	2	-	-	-	-	↓	-	-	↓	
	A,[hhll]	3D,ll,hh	$A \leftarrow A \vee [hhll]$	4	3	-	-	-	-	↓	-	-	↓	
	A,[HL]	3B	$A \leftarrow A \vee [HL]$	2	1	-	-	-	-	↓	-	-	↓	
	A,[IX]	3E	$A \leftarrow A \vee [IX]$	2	1	-	-	-	-	↓	-	-	↓	
	A,[IY]	3F	$A \leftarrow A \vee [IY]$	2	1	-	-	-	-	↓	-	-	↓	
	A,[IX+dd]	CE,38,dd	$A \leftarrow A \vee [IX+dd]$	4	3	-	-	-	-	↓	-	-	↓	
	A,[IY+dd]	CE,39,dd	$A \leftarrow A \vee [IY+dd]$	4	3	-	-	-	-	↓	-	-	↓	
	A,[IX+L]	CE,3A	$A \leftarrow A \vee [IX+L]$	4	2	-	-	-	-	↓	-	-	↓	
	A,[IY+L]	CE,3B	$A \leftarrow A \vee [IY+L]$	4	2	-	-	-	-	↓	-	-	↓	
	B,#nn	CE,B8,nn	$B \leftarrow B \vee nn$	3	3	-	-	-	-	↓	-	-	↓	
	L,#nn	CE,B9,nn	$L \leftarrow L \vee nn$	3	3	-	-	-	-	↓	-	-	↓	
	H,#nn	CE,BA,nn	$H \leftarrow H \vee nn$	3	3	-	-	-	-	↓	-	-	↓	
	SC,#nn	9E,nn	$SC \leftarrow SC \vee nn$	3	2	↓	↓	↓	↓	↓	↓	↓	↓	
	[BR:ll],#nn	DA,ll,nn	$[BR:ll] \leftarrow [BR:ll] \vee nn$	5	3	-	-	-	-	↓	-	-	↓	
	[HL],A	CE,3C	$[HL] \leftarrow [HL] \vee A$	4	2	-	-	-	-	↓	-	-	↓	
	[HL],#nn	CE,3D,nn	$[HL] \leftarrow [HL] \vee nn$	5	3	-	-	-	-	↓	-	-	↓	
	[HL],[IX]	CE,3E	$[HL] \leftarrow [HL] \vee [IX]$	5	2	-	-	-	-	↓	-	-	↓	
[HL],[IY]	CE,3F	$[HL] \leftarrow [HL] \vee [IY]$	5	2	-	-	-	-	↓	-	-	↓		
CP	A,A	30	A-A	2	1	-	-	-	-	↓	↓	↓	↓	
	A,B	31	A-B	2	1	-	-	-	-	↓	↓	↓	↓	
	A,#nn	32,nn	A-nn	2	2	-	-	-	-	↓	↓	↓	↓	
	A,[BR:ll]	34,ll	A-[BR:ll]	3	2	-	-	-	-	↓	↓	↓	↓	
	A,[hhll]	35,ll,hh	A-[hhll]	4	3	-	-	-	-	↓	↓	↓	↓	
	A,[HL]	33	A-[HL]	2	1	-	-	-	-	↓	↓	↓	↓	
	A,[IX]	36	A-[IX]	2	1	-	-	-	-	↓	↓	↓	↓	
	A,[IY]	37	A-[IY]	2	1	-	-	-	-	↓	↓	↓	↓	
	A,[IX+dd]	CE,30,dd	A-[IX+dd]	4	3	-	-	-	-	↓	↓	↓	↓	
	A,[IY+dd]	CE,31,dd	A-[IY+dd]	4	3	-	-	-	-	↓	↓	↓	↓	
	A,[IX+L]	CE,32	A-[IX+L]	4	2	-	-	-	-	↓	↓	↓	↓	
	A,[IY+L]	CE,33	A-[IY+L]	4	2	-	-	-	-	↓	↓	↓	↓	
	B,#nn	CE,BC,nn	B-nn	3	3	-	-	-	-	↓	↓	↓	↓	
	L,#nn	CE,BD,nn	L-nn	3	3	-	-	-	-	↓	↓	↓	↓	
	H,#nn	CE,BE,nn	H-nn	3	3	-	-	-	-	↓	↓	↓	↓	
	BR,#hh	CE,BF,hh	BR-hh	3	3	-	-	-	-	↓	↓	↓	↓	
	[BR:ll],#nn	DB,ll,nn	[BR:ll]-nn	4	3	-	-	-	-	↓	↓	↓	↓	

## 8-bit Arithmetic and Logic Operation Instructions (4/4)

Mnemonic	Machine Code	Operation	Cycle	Byte	SC								Comment	
					I1	I0	U	D	N	V	C	Z		
CP	[HL],A	CE,34	[HL]-A	3	2	-	-	-	-	↓	↓	↓	↓	
	[HL],#nn	CE,35,nn	[HL]-nn	4	3	-	-	-	-	↓	↓	↓	↓	
	[HL],[IX]	CE,36	[HL]-[IX]	4	2	-	-	-	-	↓	↓	↓	↓	
	[HL],[IY]	CE,37	[HL]-[IY]	4	2	-	-	-	-	↓	↓	↓	↓	
BIT	A,B	94	A∧B	2	1	-	-	-	-	↓	-	-	↓	
	A,#nn	96,nn	A∧nn	2	2	-	-	-	-	↓	-	-	↓	
	B,#nn	97,nn	B∧nn	2	2	-	-	-	-	↓	-	-	↓	
	[BR:ll],#nn	DC,ll,nn	[BR:ll]∧nn	4	3	-	-	-	-	↓	-	-	↓	
	[HL],#nn	95,nn	[HL]∧nn	3	2	-	-	-	-	↓	-	-	↓	
INC	A	80	A←A+1	2	1	-	-	-	-	-	-	-	↓	
	B	81	B←B+1	2	1	-	-	-	-	-	-	-	↓	
	L	82	L←L+1	2	1	-	-	-	-	-	-	-	↓	
	H	83	H←H+1	2	1	-	-	-	-	-	-	-	↓	
	BR	84	BR←BR+1	2	1	-	-	-	-	-	-	-	↓	
	[BR:ll]	85,ll	[BR:ll]←[BR:ll]+1	4	2	-	-	-	-	-	-	-	↓	
	[HL]	86	[HL]←[HL]+1	3	1	-	-	-	-	-	-	-	↓	
DEC	A	88	A←A-1	2	1	-	-	-	-	-	-	-	↓	
	B	89	B←B-1	2	1	-	-	-	-	-	-	-	↓	
	L	8A	L←L-1	2	1	-	-	-	-	-	-	-	↓	
	H	8B	H←H-1	2	1	-	-	-	-	-	-	-	↓	
	BR	8C	BR←BR-1	2	1	-	-	-	-	-	-	-	↓	
	[BR:ll]	8D,ll	[BR:ll]←[BR:ll]-1	4	2	-	-	-	-	-	-	-	↓	
	[HL]	8E	[HL]←[HL]-1	3	1	-	-	-	-	-	-	-	↓	
CPL	A	CE,A0	A← $\bar{A}$	3	2	-	-	-	-	↓	-	-	↓	
	B	CE,A1	B← $\bar{B}$	3	2	-	-	-	-	↓	-	-	↓	
	[BR:ll]	CE,A2,ll	[BR:ll]← $\overline{[BR:ll]}$	5	3	-	-	-	-	↓	-	-	↓	
	[HL]	CE,A3	[HL]← $\overline{[HL]}$	4	2	-	-	-	-	↓	-	-	↓	
NEG	A	CE,A4	A←0-A	3	2	-	-	★	★	↓	↓	↓	↓	
	B	CE,A5	B←0-B	3	2	-	-	★	★	↓	↓	↓	↓	
	[BR:ll]	CE,A6,ll	[BR:ll]←0-[BR:ll]	5	3	-	-	★	★	↓	↓	↓	↓	
	[HL]	CE,A7	[HL]←0-[HL]	4	2	-	-	★	★	↓	↓	↓	↓	
MLT		CE,D8	HL←L*A	12	2	-	-	-	-	↓	0	0	↓	MODEL1/3
DIV		CE,D9	L←HL/A, H←Remainder	13	2	-	-	-	-	↓	↓	0	↓	only

\* Multiplication and division instructions are set only for MODEL1/3. In MODEL0/2, these instructions cannot be used.

### 16-bit Arithmetic Operation Instructions (1/2)

Mnemonic	Machine Code	Operation	Cycle	Byte	SC								Comment	
					I1	I0	U	D	N	V	C	Z		
ADD	BA,BA	CF,00	$BA \leftarrow BA + BA$	4	2	-	-	-	-	↓	↓	↓	↓	
	BA,HL	CF,01	$BA \leftarrow BA + HL$	4	2	-	-	-	-	↓	↓	↓	↓	
	BA,IX	CF,02	$BA \leftarrow BA + IX$	4	2	-	-	-	-	↓	↓	↓	↓	
	BA,IY	CF,03	$BA \leftarrow BA + IY$	4	2	-	-	-	-	↓	↓	↓	↓	
	BA,#mmnn	C0,nn,mm	$BA \leftarrow BA + mmnn$	3	3	-	-	-	-	↓	↓	↓	↓	
	HL,BA	CF,20	$HL \leftarrow HL + BA$	4	2	-	-	-	-	↓	↓	↓	↓	
	HL,HL	CF,21	$HL \leftarrow HL + HL$	4	2	-	-	-	-	↓	↓	↓	↓	
	HL,IX	CF,22	$HL \leftarrow HL + IX$	4	2	-	-	-	-	↓	↓	↓	↓	
	HL,IY	CF,23	$HL \leftarrow HL + IY$	4	2	-	-	-	-	↓	↓	↓	↓	
	HL,#mmnn	C1,nn,mm	$HL \leftarrow HL + mmnn$	3	3	-	-	-	-	↓	↓	↓	↓	
	IX,BA	CF,40	$IX \leftarrow IX + BA$	4	2	-	-	-	-	↓	↓	↓	↓	
	IX,HL	CF,41	$IX \leftarrow IX + HL$	4	2	-	-	-	-	↓	↓	↓	↓	
	IX,#mmnn	C2,nn,mm	$IX \leftarrow IX + mmnn$	3	3	-	-	-	-	↓	↓	↓	↓	
	IY,BA	CF,42	$IY \leftarrow IY + BA$	4	2	-	-	-	-	↓	↓	↓	↓	
	IY,HL	CF,43	$IY \leftarrow IY + HL$	4	2	-	-	-	-	↓	↓	↓	↓	
	IY,#mmnn	C3,nn,mm	$IY \leftarrow IY + mmnn$	3	3	-	-	-	-	↓	↓	↓	↓	
	SP,BA	CF,44	$SP \leftarrow SP + BA$	4	2	-	-	-	-	↓	↓	↓	↓	
	SP,HL	CF,45	$SP \leftarrow SP + HL$	4	2	-	-	-	-	↓	↓	↓	↓	
SP,#mmnn	CF,68,nn,mm	$SP \leftarrow SP + mmnn$	4	4	-	-	-	-	↓	↓	↓	↓		
ADC	BA,BA	CF,04	$BA \leftarrow BA + BA + C$	4	2	-	-	-	-	↓	↓	↓	↓	
	BA,HL	CF,05	$BA \leftarrow BA + HL + C$	4	2	-	-	-	-	↓	↓	↓	↓	
	BA,IX	CF,06	$BA \leftarrow BA + IX + C$	4	2	-	-	-	-	↓	↓	↓	↓	
	BA,IY	CF,07	$BA \leftarrow BA + IY + C$	4	2	-	-	-	-	↓	↓	↓	↓	
	BA,#mmnn	CF,60,nn,mm	$BA \leftarrow BA + mmnn + C$	4	4	-	-	-	-	↓	↓	↓	↓	
	HL,BA	CF,24	$HL \leftarrow HL + BA + C$	4	2	-	-	-	-	↓	↓	↓	↓	
	HL,HL	CF,25	$HL \leftarrow HL + HL + C$	4	2	-	-	-	-	↓	↓	↓	↓	
	HL,IX	CF,26	$HL \leftarrow HL + IX + C$	4	2	-	-	-	-	↓	↓	↓	↓	
	HL,IY	CF,27	$HL \leftarrow HL + IY + C$	4	2	-	-	-	-	↓	↓	↓	↓	
	HL,#mmnn	CF,61,nn,mm	$HL \leftarrow HL + mmnn + C$	4	4	-	-	-	-	↓	↓	↓	↓	
SUB	BA,BA	CF,08	$BA \leftarrow BA - BA$	4	2	-	-	-	-	↓	↓	↓	↓	
	BA,HL	CF,09	$BA \leftarrow BA - HL$	4	2	-	-	-	-	↓	↓	↓	↓	
	BA,IX	CF,0A	$BA \leftarrow BA - IX$	4	2	-	-	-	-	↓	↓	↓	↓	
	BA,IY	CF,0B	$BA \leftarrow BA - IY$	4	2	-	-	-	-	↓	↓	↓	↓	
	BA,#mmnn	D0,nn,mm	$BA \leftarrow BA - mmnn$	3	3	-	-	-	-	↓	↓	↓	↓	
	HL,BA	CF,28	$HL \leftarrow HL - BA$	4	2	-	-	-	-	↓	↓	↓	↓	
	HL,HL	CF,29	$HL \leftarrow HL - HL$	4	2	-	-	-	-	↓	↓	↓	↓	
	HL,IX	CF,2A	$HL \leftarrow HL - IX$	4	2	-	-	-	-	↓	↓	↓	↓	
	HL,IY	CF,2B	$HL \leftarrow HL - IY$	4	2	-	-	-	-	↓	↓	↓	↓	
	HL,#mmnn	D1,nn,mm	$HL \leftarrow HL - mmnn$	3	3	-	-	-	-	↓	↓	↓	↓	
	IX,BA	CF,48	$IX \leftarrow IX - BA$	4	2	-	-	-	-	↓	↓	↓	↓	
	IX,HL	CF,49	$IX \leftarrow IX - HL$	4	2	-	-	-	-	↓	↓	↓	↓	
	IX,#mmnn	D2,nn,mm	$IX \leftarrow IX - mmnn$	3	3	-	-	-	-	↓	↓	↓	↓	
	IY,BA	CF,4A	$IY \leftarrow IY - BA$	4	2	-	-	-	-	↓	↓	↓	↓	
	IY,HL	CF,4B	$IY \leftarrow IY - HL$	4	2	-	-	-	-	↓	↓	↓	↓	
	IY,#mmnn	D3,nn,mm	$IY \leftarrow IY - mmnn$	3	3	-	-	-	-	↓	↓	↓	↓	
	SP,BA	CF,4C	$SP \leftarrow SP - BA$	4	2	-	-	-	-	↓	↓	↓	↓	
	SP,HL	CF,4D	$SP \leftarrow SP - HL$	4	2	-	-	-	-	↓	↓	↓	↓	
SP,#mmnn	CF,6A,nn,mm	$SP \leftarrow SP - mmnn$	4	4	-	-	-	-	↓	↓	↓	↓		





## 16-bit Arithmetic Operation Instructions (2/2)

Mnemonic	Machine Code	Operation	Cycle	Byte	SC								Comment	
					I1	IO	U	D	N	V	C	Z		
SBC	BA,BA	CF,0C	$BA \leftarrow BA - BA - C$	4	2	-	-	-	-	↓	↓	↓	↓	
	BA,HL	CF,0D	$BA \leftarrow BA - HL - C$	4	2	-	-	-	-	↓	↓	↓	↓	
	BA,IX	CF,0E	$BA \leftarrow BA - IX - C$	4	2	-	-	-	-	↓	↓	↓	↓	
	BA,IY	CF,0F	$BA \leftarrow BA - IY - C$	4	2	-	-	-	-	↓	↓	↓	↓	
	BA,#mmnn	CF,62,nn,mm	$BA \leftarrow BA - mmnn - C$	4	4	-	-	-	-	↓	↓	↓	↓	
	HL,BA	CF,2C	$HL \leftarrow HL - BA - C$	4	2	-	-	-	-	↓	↓	↓	↓	
	HL,HL	CF,2D	$HL \leftarrow HL - HL - C$	4	2	-	-	-	-	↓	↓	↓	↓	
	HL,IX	CF,2E	$HL \leftarrow HL - IX - C$	4	2	-	-	-	-	↓	↓	↓	↓	
	HL,IY	CF,2F	$HL \leftarrow HL - IY - C$	4	2	-	-	-	-	↓	↓	↓	↓	
	HL,#mmnn	CF,63,nn,mm	$HL \leftarrow HL - mmnn - C$	4	4	-	-	-	-	↓	↓	↓	↓	
CP	BA,BA	CF,18	$BA - BA$	4	2	-	-	-	-	↓	↓	↓	↓	
	BA,HL	CF,19	$BA - HL$	4	2	-	-	-	-	↓	↓	↓	↓	
	BA,IX	CF,1A	$BA - IX$	4	2	-	-	-	-	↓	↓	↓	↓	
	BA,IY	CF,1B	$BA - IY$	4	2	-	-	-	-	↓	↓	↓	↓	
	BA,#mmnn	D4,nn,mm	$BA - mmnn$	3	3	-	-	-	-	↓	↓	↓	↓	
	HL,BA	CF,38	$HL - BA$	4	2	-	-	-	-	↓	↓	↓	↓	
	HL,HL	CF,39	$HL - HL$	4	2	-	-	-	-	↓	↓	↓	↓	
	HL,IX	CF,3A	$HL - IX$	4	2	-	-	-	-	↓	↓	↓	↓	
	HL,IY	CF,3B	$HL - IY$	4	2	-	-	-	-	↓	↓	↓	↓	
	HL,#mmnn	D5,nn,mm	$HL - mmnn$	3	3	-	-	-	-	↓	↓	↓	↓	
	IX,#mmnn	D6,nn,mm	$IX - mmnn$	3	3	-	-	-	-	↓	↓	↓	↓	
	IY,#mmnn	D7,nn,mm	$IY - mmnn$	3	3	-	-	-	-	↓	↓	↓	↓	
	SP,BA	CF,5C	$SP - BA$	4	2	-	-	-	-	↓	↓	↓	↓	
	SP,HL	CF,5D	$SP - HL$	4	2	-	-	-	-	↓	↓	↓	↓	
SP,#mmnn	CF,6C,nn,mm	$SP - mmnn$	4	4	-	-	-	-	↓	↓	↓	↓		
INC	BA	90	$BA \leftarrow BA + 1$	2	1	-	-	-	-	-	-	-	↓	
	HL	91	$HL \leftarrow HL + 1$	2	1	-	-	-	-	-	-	-	↓	
	IX	92	$IX \leftarrow IX + 1$	2	1	-	-	-	-	-	-	-	↓	
	IY	93	$IY \leftarrow IY + 1$	2	1	-	-	-	-	-	-	-	↓	
	SP	87	$SP \leftarrow SP + 1$	2	1	-	-	-	-	-	-	-	↓	
DEC	BA	98	$BA \leftarrow BA - 1$	2	1	-	-	-	-	-	-	-	↓	
	HL	99	$HL \leftarrow HL - 1$	2	1	-	-	-	-	-	-	-	↓	
	IX	9A	$IX \leftarrow IX - 1$	2	1	-	-	-	-	-	-	-	↓	
	IY	9B	$IY \leftarrow IY - 1$	2	1	-	-	-	-	-	-	-	↓	
	SP	8F	$SP \leftarrow SP - 1$	2	1	-	-	-	-	-	-	-	↓	

## Auxiliary Operation Instructions

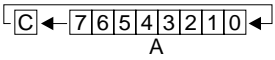
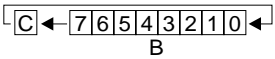
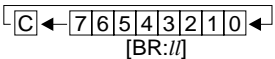
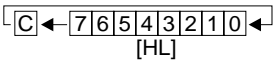
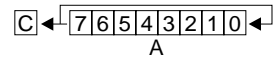
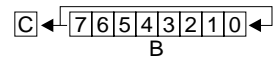
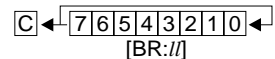
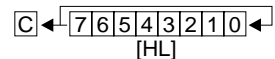
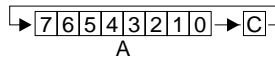
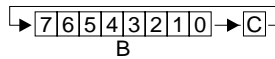
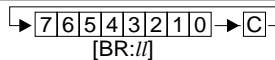
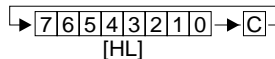
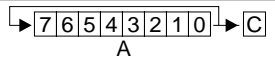
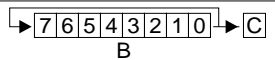
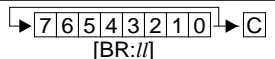
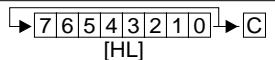
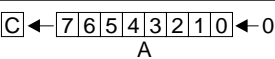
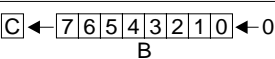
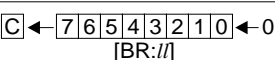
Mnemonic	Machine Code	Operation	Cycle	Byte	SC								Comment	
					I1	IO	U	D	N	V	C	Z		
PACK	DE	$\begin{array}{ c c } \hline B & A \\ \hline *m & *n \\ \hline \end{array} \rightarrow \begin{array}{ c } \hline A \\ \hline mn \\ \hline \end{array}$	2	1	-	-	-	-	-	-	-	-	-	
UPCK	DF	$\begin{array}{ c } \hline A \\ \hline mn \\ \hline \end{array} \rightarrow \begin{array}{ c c c } \hline B & & A \\ \hline 0 & m & 0 & n \\ \hline \end{array}$	2	1	-	-	-	-	-	-	-	-		
SEP	CE,A8	$\begin{array}{ c c } \hline B & A \\ \hline 0***** & \rightarrow 00000000 \\ \hline 1***** & \rightarrow 11111111 \\ \hline \end{array}$	3	2	-	-	-	-	-	-	-	-		

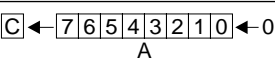
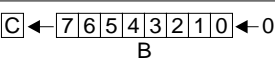
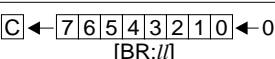
### Rotate/Shift Instructions (1/2)

Mnemonic	Machine Code	Operation	Cycle	Byte	SC							Comment		
					I1	I0	U	D	N	V	C		Z	
RL	A	CE,90		3	2	-	-	-	-	↑	-	↑	↑	
	B	CE,91		3	2	-	-	-	-	↑	-	↑	↑	
	[BR:II]	CE,92,II		5	3	-	-	-	-	↑	-	↑	↑	
	[HL]	CE,93		4	2	-	-	-	-	↑	-	↑	↑	
RLC	A	CE,94		3	2	-	-	-	-	↑	-	↑	↑	
	B	CE,95		3	2	-	-	-	-	↑	-	↑	↑	
	[BR:II]	CE,96,II		5	3	-	-	-	-	↑	-	↑	↑	
	[HL]	CE,97		4	2	-	-	-	-	↑	-	↑	↑	
RR	A	CE,98		3	2	-	-	-	-	↑	-	↑	↑	
	B	CE,99		3	2	-	-	-	-	↑	-	↑	↑	
	[BR:II]	CE,9A,II		5	3	-	-	-	-	↑	-	↑	↑	
	[HL]	CE,9B		4	2	-	-	-	-	↑	-	↑	↑	
RRC	A	CE,9C		3	2	-	-	-	-	↑	-	↑	↑	
	B	CE,9D		3	2	-	-	-	-	↑	-	↑	↑	
	[BR:II]	CE,9E,II		5	3	-	-	-	-	↑	-	↑	↑	
	[HL]	CE,9F		4	2	-	-	-	-	↑	-	↑	↑	
SLA	A	CE,80		3	2	-	-	-	-	↑	↑	↑	↑	
	B	CE,81		3	2	-	-	-	-	↑	↑	↑	↑	
	[BR:II]	CE,82,II		5	3	-	-	-	-	↑	↑	↑	↑	
	[HL]	CE,83		4	2	-	-	-	-	↑	↑	↑	↑	
SLL	A	CE,84		3	2	-	-	-	-	↑	-	↑	↑	
	B	CE,85		3	2	-	-	-	-	↑	-	↑	↑	
	[BR:II]	CE,86,II		5	3	-	-	-	-	↑	-	↑	↑	
	[HL]	CE,87		4	2	-	-	-	-	↑	-	↑	↑	

### Rotate/Shift Instructions (2/2)

Mnemonic	Machine Code	Operation	Cycle	Byte	SC								Comment	
					I1	I0	U	D	N	V	C	Z		
SRA	A	CE,88		3	2	-	-	-	-	↓	0	↓	↓	
	B	CE,89		3	2	-	-	-	-	↓	0	↓	↓	
	[BR://]	CE,8A,//		5	3	-	-	-	-	↓	0	↓	↓	
	[HL]	CE,8B		4	2	-	-	-	-	↓	0	↓	↓	
SRL	A	CE,8C		3	2	-	-	-	-	0	-	↓	↓	
	B	CE,8D		3	2	-	-	-	-	0	-	↓	↓	
	[BR://]	CE,8E,//		5	3	-	-	-	-	0	-	↓	↓	
	[HL]	CE,8F		4	2	-	-	-	-	0	-	↓	↓	

### Stack Control Instructions

Mnemonic	Machine Code	Operation	Cycle	Byte	SC								Comment	
					I1	I0	U	D	N	V	C	Z		
PUSH	A	CF,B0	[SP-1]←A, SP←SP-1	3	2	-	-	-	-	-	-	-	-	
	B	CF,B1	[SP-1]←B, SP←SP-1	3	2	-	-	-	-	-	-	-	-	
	L	CF,B2	[SP-1]←L, SP←SP-1	3	2	-	-	-	-	-	-	-	-	
	H	CF,B3	[SP-1]←H, SP←SP-1	3	2	-	-	-	-	-	-	-	-	
	BR	A4	[SP-1]←BR, SP←SP-1	3	1	-	-	-	-	-	-	-	-	
	SC	A7	[SP-1]←SC, SP←SP-1	3	1	-	-	-	-	-	-	-	-	
	BA	A0	[SP-1]←B, [SP-2]←A, SP←SP-2	4	1	-	-	-	-	-	-	-	-	
	HL	A1	[SP-1]←H, [SP-2]←L, SP←SP-2	4	1	-	-	-	-	-	-	-	-	
	IX	A2	[SP-1]←IX(H), [SP-2]←IX(L), SP←SP-2	4	1	-	-	-	-	-	-	-	-	
	IY	A3	[SP-1]←IY(H), [SP-2]←IY(L), SP←SP-2	4	1	-	-	-	-	-	-	-	-	
	EP	A5	[SP-1]←EP, SP←SP-1	3	1	-	-	-	-	-	-	-	-	
IP	A6	[SP-1]←XP, [SP-2]←YP, SP←SP-2	4	1	-	-	-	-	-	-	-	-		
PUSH	ALL	CF,B8	PUSH BA, HL, IX, IY, BR	12	2	-	-	-	-	-	-	-	-	
	ALE	CF,B9	PUSH BA, HL, IX, IY, BR, EP, IP	15	2	-	-	-	-	-	-	-	-	MODEL2/3 only
POP	A	CF,B4	A←[SP], SP←SP+1	3	2	-	-	-	-	-	-	-	-	
	B	CF,B5	B←[SP], SP←SP+1	3	2	-	-	-	-	-	-	-	-	
	L	CF,B6	L←[SP], SP←SP+1	3	2	-	-	-	-	-	-	-	-	
	H	CF,B7	H←[SP], SP←SP+1	3	2	-	-	-	-	-	-	-	-	
	BR	AC	BR←[SP], SP←SP+1	2	1	-	-	-	-	-	-	-	-	
	SC	AF	SC←[SP], SP←SP+1	2	1	↓	↓	↓	↓	↓	↓	↓	↓	
	BA	A8	A←[SP], B←[SP+1], SP←SP+2	3	1	-	-	-	-	-	-	-	-	
	HL	A9	L←[SP], H←[SP+1], SP←SP+2	3	1	-	-	-	-	-	-	-	-	
	IX	AA	IX(L)←[SP], IX(H)←[SP+1], SP←SP+2	3	1	-	-	-	-	-	-	-	-	
	IY	AB	IY(L)←[SP], IY(H)←[SP+1], SP←SP+2	3	1	-	-	-	-	-	-	-	-	
	EP	AD	EP←[SP], SP←SP+1	2	1	-	-	-	-	-	-	-	-	
IP	AE	YP←[SP], XP←[SP+1], SP←SP+2	3	1	-	-	-	-	-	-	-	-		
POP	ALL	CF,BC	POP BR, IY, IX, HL, BA	11	2	-	-	-	-	-	-	-	-	
	ALE	CF,BD	POP IP, EP, BR, IY, IX, HL, BA	14	2	-	-	-	-	-	-	-	-	MODEL2/3 only

\* Expand page registers EP/XP/YP are set only for MODEL2/3. In MODEL0/1, instructions that access these registers cannot be used.



**Branch Instructions (1/4)**

Mnemonic		Machine Code	Condition	Operation	Cycle	Byte	SC							
							11	10	U	D	N	V	C	Z
JRS	rr	F1,rr	Unconditional	MODEL0/1 PC←PC+rr+1	2	2	-	-	-	-	-	-	-	-
				MODEL2/3 PC←PC+rr+1, CB←NB										
JRS	C,rr	E4,rr	C=1	MODEL0/1 If Condition is true, then PC←PC+rr+1 ----- else PC←PC+2  MODEL2/3 If Condition is true, then PC←PC+rr+1, CB←NB ----- else PC←PC+2, NB←CB	2	2	-	-	-	-	-	-	-	-
	NC,rr	E5,rr	C=0											
	Z,rr	E6,rr	Z=1											
	NZ,rr	E7,rr	Z=0											
JRS	LT,rr	CE,E0,rr	[N∨V]=1	MODEL0/1 If Condition is true, then PC←PC+rr+2 ----- else PC←PC+3  MODEL2/3 If Condition is true, then PC←PC+rr+2, CB←NB ----- else PC←PC+3, NB←CB	3	3	-	-	-	-	-	-	-	-
	LE,rr	CE,E1,rr	Z∨[N∨V]=1											
	GT,rr	CE,E2,rr	Z∨[N∨V]=0											
	GE,rr	CE,E3,rr	[N∨V]=0											
	V,rr	CE,E4,rr	V=1											
	NV,rr	CE,E5,rr	V=0											
	P,rr	CE,E6,rr	N=0											
	M,rr	CE,E7,rr	N=1											
	F0,rr	CE,E8,rr	F0=1											
	F1,rr	CE,E9,rr	F1=1											
	F2,rr	CE,EA,rr	F2=1											
	F3,rr	CE,EB,rr	F3=1											
	NF0,rr	CE,EC,rr	F0=0											
	NF1,rr	CE,ED,rr	F1=0											
	NF2,rr	CE,EE,rr	F2=0											
NF3,rr	CE,EF,rr	F3=0												
JRL	qqrr	F3,rr,qq	Unconditional	MODEL0/1 PC←PC+qqrr+2	3	3	-	-	-	-	-	-	-	-
				MODEL2/3 PC←PC+qqrr+2, CB←NB										
JRL	C,qqrr	EC,rr,qq	C=1	MODEL0/1 If Condition is true, then PC←PC+qqrr+2 ----- else PC←PC+3  MODEL2/3 If Condition is true, then PC←PC+qqrr+2, CB←NB ----- else PC←PC+3, NB←CB	3	3	-	-	-	-	-	-	-	-
	NC,qqrr	ED,rr,qq	C=0											
	Z,qqrr	EE,rr,qq	Z=1											
	NZ,qqrr	EF,rr,qq	Z=0											
DJR	NZ,rr	F5,rr	B=0	MODEL0/1 B←B-1, If B=0, then PC←PC+rr+1 ----- else PC←PC+2  MODEL2/3 B←B-1, If B=0, then PC←PC+rr+1, CB←NB ----- else PC←PC+2, NB←CB	4	2	-	-	-	-	-	-	-	↑

Branch Instructions (2/4)

Mnemonic		Machine Code	Condition	Operation	Cycle	Byte	SC							
							I	1	0	U	D	N	V	C
JP	HL	F4	Unconditional	<i>MODEL0/1</i> PC←HL <i>MODEL2/3</i> PC←HL, CB←NB	2	1	-	-	-	-	-	-	-	-
	[kk]	FD,kk	Unconditional	<i>MODEL0/1</i> PC(L)←[00kk], PC(H)←[00kk+1] <i>MODEL2/3</i> PC(L)←[00kk] PC(H)←[00kk+1], CB←NB	4	2	-	-	-	-	-	-	-	-
CARS	rr	F0,rr	Unconditional	<i>MODEL0/1</i> [SP-1]←PC(H), [SP-2]←PC(L), SP←SP-2, PC←PC+rr+1	4	2	-	-	-	-	-	-	-	-
				<i>MODEL2/3 (Minimum mode)</i> [SP-1]←PC(H), [SP-2]←PC(L), SP←SP-2, PC←PC+rr+1, CB←NB	5									
				<i>MODEL2/3 (Maximum mode)</i> [SP-1]←CB, [SP-2]←PC(H), [SP-3]←PC(L), SP←SP-3, PC←PC+rr+1, CB←NB	5									
CARS	C,rr	E0,rr	C=1	<i>MODEL0/1</i> If Condition is true then [SP-1]←PC(H), [SP-2]←PC(L), SP←SP-2, PC←PC+rr+1 ----- else PC←PC+2	4	2	-	-	-	-	-	-	-	-
				<i>MODEL2/3 (Minimum mode)</i> If Condition is true then [SP-1]←PC(H), [SP-2]←PC(L), SP←SP-2, PC←PC+rr+1, CB←NB ----- else PC←PC+2, NB←CB	4									
	<i>MODEL2/3 (Maximum mode)</i> If Condition is true then [SP-1]←CB, [SP-2]←PC(H), [SP-3]←PC(L), SP←SP-3, PC←PC+rr+1, CB←NB ----- else PC←PC+2, NB←CB	5												
	----- else PC←PC+2, NB←CB	2												
NC,rr	E1,rr	C=0	C=0	----- else PC←PC+2	2									
				----- else PC←PC+2, NB←CB	2									
Z,rr	E2,rr	Z=1	Z=1	----- else PC←PC+2, NB←CB	2									
NZ,rr	E3,rr	Z=0	Z=0	----- else PC←PC+2, NB←CB	2									
CARS	LT,rr	CE,F0,rr	[N∨V]=1	<i>MODEL0/1</i> If Condition is true then [SP-1]←PC(H), [SP-2]←PC(L), SP←SP-2, PC←PC+rr+2 ----- else PC←PC+3	5	3	-	-	-	-	-	-	-	-
	LE,rr	CE,F1,rr	Z∨[N∨V]=1	----- else PC←PC+3	3									
	GT,rr	CE,F2,rr	Z∨[N∨V]=0	<i>MODEL2/3 (Minimum mode)</i> If Condition is true then [SP-1]←PC(H), [SP-2]←PC(L), SP←SP-2, PC←PC+rr+2, CB←NB ----- else PC←PC+3, NB←CB	5									
	GE,rr	CE,F3,rr	[N∨V]=0	----- else PC←PC+3, NB←CB	3									
	V,rr	CE,F4,rr	V=1	----- else PC←PC+3, NB←CB	3									
	NV,rr	CE,F5,rr	V=0	<i>MODEL2/3 (Maximum mode)</i> If Condition is true then [SP-1]←CB, [SP-2]←PC(H), [SP-3]←PC(L), SP←SP-3, PC←PC+rr+2, CB←NB ----- else PC←PC+3, NB←CB	6									
	P,rr	CE,F6,rr	N=0	----- else PC←PC+3, NB←CB	3									
	M,rr	CE,F7,rr	N=1	----- else PC←PC+3, NB←CB	3									
	F0,rr	CE,F8,rr	F0=1	----- else PC←PC+3, NB←CB	3									
	F1,rr	CE,F9,rr	F1=1	----- else PC←PC+3, NB←CB	3									
	F2,rr	CE,FA,rr	F2=1	----- else PC←PC+3, NB←CB	3									
	F3,rr	CE,FB,rr	F3=1	----- else PC←PC+3, NB←CB	3									
	NF0,rr	CE,FC,rr	F0=0	----- else PC←PC+3, NB←CB	3									
	NF1,rr	CE,FD,rr	F1=0	----- else PC←PC+3, NB←CB	3									
	NF2,rr	CE,FE,rr	F2=0	----- else PC←PC+3, NB←CB	3									
NF3,rr	CE,FF,rr	F3=0	----- else PC←PC+3, NB←CB	3										

### Branch Instructions (3/4)

Mnemonic		Machine Code	Condition	Operation	Cycle	Byte	SC							
							1	0	U	D	N	V	C	Z
CARL	qqr	F2,rr,qq	Unconditionable	<i>MODEL0/1</i> [SP-1]←PC(H), [SP-2]←PC(L), SP←SP-2, PC←PC+qqr+2	5	3	-	-	-	-	-	-	-	-
				<i>MODEL2/3 (Minimum mode)</i> [SP-1]←PC(H), [SP-2]←PC(L), SP←SP-2, PC←PC+qqr+2, CB←NB										
				<i>MODEL2/3 (Maximum mode)</i> [SP-1]←CB, [SP-2]←PC(H), [SP-3]←PC(L), SP←SP-3, PC←PC+qqr+2, CB←NB	6									
CARL	C,qqr	E8,rr,qq	C=1	<i>MODEL0/1</i> If Condition is true then [SP-1]←PC(H), [SP-2]←PC(L), SP←SP-2, PC←PC+qqr+2 ----- else PC←PC+3	5	3	-	-	-	-	-	-	-	-
				<i>MODEL2/3 (Minimum mode)</i> If Condition is true then [SP-1]←PC(H), [SP-2]←PC(L), SP←SP-2, PC←PC+qqr+2, CB←NB ----- else PC←PC+3, NB←CB										
	NC,qqr	E9,rr,qq	C=0	<i>MODEL2/3 (Minimum mode)</i> If Condition is true then [SP-1]←PC(H), [SP-2]←PC(L), SP←SP-2, PC←PC+qqr+2, CB←NB ----- else PC←PC+3, NB←CB	5	3	-	-	-	-	-	-	-	-
				<i>MODEL2/3 (Maximum mode)</i> If Condition is true then [SP-1]←CB, [SP-2]←PC(H), [SP-3]←PC(L), SP←SP-3, PC←PC+qqr+2, CB←NB ----- else PC←PC+3, NB←CB										
Z,qqr	EA,rr,qq	Z=1	----- else PC←PC+3, NB←CB	3										
NZ,qqr	EB,rr,qq	Z=0	----- else PC←PC+3, NB←CB	3										
CALL	[hh/l]	FB,,ll,hh	Unconditionable	<i>MODEL0/1</i> [SP-1]←PC(H), [SP-2]←PC(L), SP←SP-2, PC(L)←[hh/l], PC(H)←[hh/l+1]	7	3	-	-	-	-	-	-	-	-
				<i>MODEL2/3 (Minimum mode)</i> [SP-1]←PC(H), [SP-2]←PC(L), SP←SP-2, PC(L)←[hh/l], PC(H)←[hh/l+1], CB←NB										
				<i>MODEL2/3 (Maximum mode)</i> [SP-1]←CB, [SP-2]←PC(H), [SP-3]←PC(L), SP←SP-3, PC(L)←[hh/l], PC(H)←[hh/l+1], CB←NB	8									

### Branch Instructions (4/4)

Mnemonic	Machine Code	Operation	Cycle	Byte	SC								Comment
					I1	I0	U	D	N	V	C	Z	
INT	[kk]	FC,kk <i>MODEL0/1</i> [SP-1]←PC(H), [SP-2]←PC(L), [SP-3]←SC, SP←SP-3, PC(L)←[00kk], PC(H)←[00kk+1]	7	2	-	-	-	-	-	-	-	-	
													<i>MODEL2/3 (Minimum mode)</i> [SP-1]←PC(H), [SP-2]←PC(L), [SP-3]←SC, SP←SP-3, PC(L)←[00kk], PC(H)←[00kk+1], CB←NB
		<i>MODEL2/3 (Maximum mode)</i> [SP-1]←CB, [SP-2]←PC(H), [SP-3]←PC(L), [SP-4]←SC, SP←SP-4, PC(L)←[00kk], PC(H)←[00kk+1], CB←NB	8										
RET	F8	<i>MODEL0/1, MODEL2/3 (Minimum mode)</i> PC(L)←[SP], PC(H)←[SP+1], SP←SP+2	3	1	-	-	-	-	-	-	-	-	
		<i>MODEL2/3 (Maximum mode)</i> PC(L)←[SP], PC(H)←[SP+1], CB←[SP+2], NB←CB, SP←SP+3	4										
RETE	F9	<i>MODEL0/1, MODEL2/3 (Minimum mode)</i> SC←[SP], PC(L)←[SP+1], PC(H)←[SP+2], SP←SP+3	4	1	↑	↑	↑	↑	↑	↑	↑	↑	
		<i>MODEL2/3 (Maximum mode)</i> SC←[SP], PC(L)←[SP+1], PC(H)←[SP+2], CB←[SP+3], NB←CB, SP←SP+4	5										
RETS	FA	<i>MODEL0/1, MODEL2/3 (Minimum mode)</i> PC(L)←[SP], PC(H)←[SP+1], SP←SP+2, PC←PC+2	5	1	-	-	-	-	-	-	-	-	
		<i>MODEL2/3 (Maximum mode)</i> PC(L)←[SP], PC(H)←[SP+1], CB←[SP+2], NB←CB, SP←SP+3, PC←PC+2	6										

### System Control Instructions

Mnemonic	Machine Code	Operation	Cycle	Byte	SC								Comment
					I1	I0	U	D	N	V	C	Z	
NOP	FF	No Operation	2	1	-	-	-	-	-	-	-	-	
HALT	CE,AE	HALT	3	2	-	-	-	-	-	-	-	-	
SLP	CE,AF	SLEEP	3	2	-	-	-	-	-	-	-	-	

## Appendix C Programming Notes

### System Controller and Bus Control

- (1) All the interrupts including  $\overline{\text{NMI}}$  are masked, until you write the optional value into both the "00FF00H" and "00FF01H" addresses. Consequently, even if you do not change the content of this address (You use the initial value, as is.), you should still be sure to perform the writing operation using the initialization routine.
- (2) When setting stack fields, including page addresses as well, you should write them in the order of the register SPP ("00FF01H") and the stack pointer SP.

Example: When setting the "178000H" address

```
LD EP, #00H
LD HL, #0FF01H
LD [HL], #17H
LD SP, #8000H
```

] During this period the  
interrupts (including  
 $\overline{\text{NMI}}$ ) are masked.

### Watchdog Timer

- (1) The watchdog timer must reset within 3-second cycles by software.
- (2) Do not execute the SLP instruction for 2 msec after a  $\overline{\text{NMI}}$  interrupt has occurred (when  $f_{\text{OSC1}}$  is 32.768 kHz).

### Oscillation Circuit and Operating Mode

- (1) When the high speed CPU operation is not necessary, you should operate the peripheral circuits according to the setting outline indicate below.
  - CPU operating clock  
OSC1
  - OSC3 oscillation circuit  
OFF (When the OSC3 clock is not necessary for some peripheral circuits.)
  - Operating mode  
Low power mode  
(When  $V_{\text{DD}}-V_{\text{SS}}$  is 3.5 V or less)  
or Normal mode  
(When  $V_{\text{DD}}-V_{\text{SS}}$  is 3.5 V or more)
- (2) Do not turn the OSC3 oscillation circuit ON in the low power mode.  
Do not switch over the operating mode (normal mode  $\leftrightarrow$  high speed mode) in the OSC3 oscillation circuit ON status, as this will cause faulty operation.

- (3) When turning ON the OSC3 oscillation circuit after switching the operating mode, you should allow a minimum waiting time of 5 msec.
- (4) Since several msec to several tens of msec are necessary for the oscillation to stabilize after turning the OSC3 oscillation circuit ON. Consequently, you should switch the CPU operating clock (OSC1  $\rightarrow$  OSC3) after allowing for a sufficient waiting time once the OSC3 oscillation goes ON. (The oscillation start time will vary somewhat depending on the oscillator and on the externally attached parts. Refer to the oscillation start time example indicated in Chapter 7/Technical Hardware, "ELECTRICAL CHARACTERISTICS".)
- (5) When switching the clock from OSC3 to OSC1, be sure to switch OSC3 oscillation OFF with separate instructions. Using a single instruction to process simultaneously can cause a malfunction of the CPU.

### Input Port (K Port)

When changing the input terminal from LOW level to HIGH with the built-in pull-up resistor, a delay in the waveform rise time will occur depending on the time constant of the pull-up resistor and the load capacitance of the terminal. It is necessary to set an appropriate wait time for introduction of an input port. In particular, special attention should be paid to key scan for key matrix formation. Make this wait time the amount of time or more calculated by the following expression.

Wait time =  $R_{\text{IN}} \times (C_{\text{IN}} + \text{load capacitance on the board}) \times 1.6$  [sec]

$R_{\text{IN}}$ : Pull up resistance Max. value

$C_{\text{IN}}$ : Terminal capacitance Max. value

### Output Port (R port)

- (1) Since the special output signals (CL, FR, TOUT, FOUT and BZ) are generated asynchronously from the output control registers (LCCLK, LCFRM, PTOUT, FOUTON, BZON, BZSHT and BZSTP), when the signals is turned ON or OFF by the output control register settings, a hazard of a 1/2 cycle or less is generated.

- (2) When the FOUT frequency is made "fosc3/n", you must turn on the OSC3 oscillation circuit before outputting FOUT. A time interval of several msec to several 10 msec, from the turning ON of the OSC3 oscillation circuit to until the oscillation stabilizes, is necessary, due to the oscillation element that is used. Consequently, if an abnormality occurs as the result of an unstable FOUT signal being output externally, you should allow an adequate waiting time after turning ON of the OSC3 oscillation, before turning outputting FOUT. (The oscillation start time will vary somewhat depending on the oscillator and on the externally attached parts. Refer to the oscillation start time example indicated in Chapter 7/Technical Hardware, "ELECTRICAL CHARACTERISTICS".)  
At initial reset, OSC3 oscillation circuit is set to OFF state.
- (3) The SLP instruction has executed when the special output signals (TOUT, FOUT and BZ) are in the enable status, an unstable clock is output for the special output at the time of return from the SLEEP state. Consequently, when shifting to the SLEEP state, you should set the special output signal to the disable status prior to executing the SLP instruction.

**I/O Port (P Port)**

- (1) When changing the port terminal from LOW level to HIGH with the built-in pull-up resistor, a delay in the waveform rise time will occur depending on the time constant of the pull-up resistor and the load capacitance of the terminal. It is necessary to set an appropriate wait time for introduction of an I/O port. Make this wait time the amount of time or more calculated by the following expression.  
  
 Wait time =  $R_{IN} \times (C_{IN} + \text{load capacitance on the board}) \times 1.6$  [sec]  
 R<sub>IN</sub>: Pull up resistance Max. value  
 C<sub>IN</sub>: Terminal capacitance Max. value
- (2) When the analog comparator is used, "0" must always be set for the I/O control registers (IOC14–IOC15 or IOC16–IOC17, or both) of I/O ports which will become input terminals.

**Serial Interface**

- (1) Be sure to initialize the serial interface mode in the transmitting/receiving disable status (TXEN = RXEN = "0").

- (2) Do not perform double trigger (writing "1") to TXTRG (RXTRG) when the serial interface is in the transmitting (receiving) operation. Furthermore, do not execute the SLP instruction. (When executing the SLP instruction, set TXEN = RXEN = "0".)
- (3) In the clock synchronous mode, since one clock line (SCLK) is shared for both transmitting and receiving, transmitting and receiving cannot be performed simultaneously. (Half duplex only is possible in clock synchronous mode.) Consequently, be sure not to write "1" to RXTRG (TXTRG) when TXTRG (RXTRG) is "1".
- (4) When a parity error or framing error is generated during receiving in the asynchronous mode, the receiving error interrupt factor flag FSERR is set to "1" prior to the receiving complete interrupt factor flag FSREC for the time indicated in Table C.1. Consequently, when an error is generated, you should reset the receiving complete interrupt factor flag FSREC to "0" by providing a wait time in error processing routines and similar routines.  
When an overrun error is generated, the receiving complete interrupt factor flag FSREC is not set to "1" and a receiving complete interrupt is not generated.

*Table C.1 Time difference between FSERR and FSREC on error generation*

Clock source	Time difference
fosc3 / n	1/2 cycles of fosc3 / n
Programmable timer	1 cycle of timer 1 underflow

- (5) When the demultiplied signal of the OSC3 oscillation circuit is made the clock source, it is necessary to turn the OSC3 oscillation ON, prior to using the serial interface.  
A time interval of several msec to several 10 msec, from the turning ON of the OSC3 oscillation circuit to until the oscillation stabilizes, is necessary, due to the oscillation element that is used. Consequently, you should allow an adequate waiting time after turning ON of the OSC3 oscillation, before starting transmitting/receiving of serial interface. (The oscillation start time will vary somewhat depending on the oscillator and on the externally attached parts. Refer to the oscillation start time example indicated in Chapter 7/Technical Hardware, "ELECTRICAL CHARACTERISTICS".)  
At initial reset, the OSC3 oscillation circuit is set to OFF status.

**Clock Timer**

- (1) The clock timer is actually made to RUN/STOP in synchronization with the falling edge of the 256 Hz signal after writing to the TMRUN register. Consequently, when "0" is written to the TMRUN, the timer shifts to STOP status when the counter is incremented "1". The TMRUN maintains "1" for reading until the timer actually shifts to STOP status. Figure C.1 shows the timing chart of the RUN/STOP control.

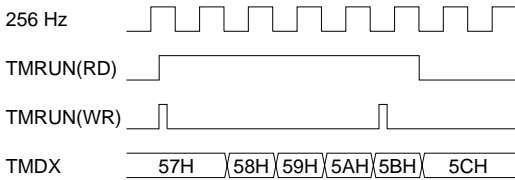

Fig. C.1 Timing chart of RUN/STOP control

- (2) The SLP instruction is executed when the clock timer is in the RUN status (TMRUN = "1"). The clock timer operation will become unstable when returning from SLEEP status. Therefore, when shifting to SLEEP status, set the clock timer to STOP status (TMRUN = "0") prior to executing the SLP instruction.

**Stopwatch Timer**

- (1) The stopwatch timer is actually made to RUN/STOP in synchronization with the falling edge of the 256 Hz signal after writing to the SWRUN register. Consequently, when "0" is written to the SWRUN, the timer shifts to STOP status when the counter is incremented "1". The SWRUN maintains "1" for reading until the timer actually shifts to STOP status. Figure C.2 shows the timing chart of the RUN/STOP control.

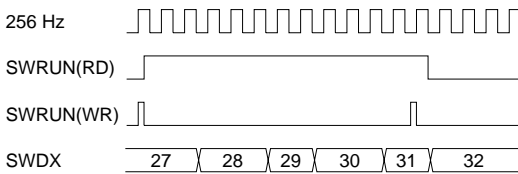

Fig. C.2 Timing chart of RUN/STOP control

- (2) The SLP instruction is executed when the stopwatch timer is in the RUN status (SWRUN = "1"). The stopwatch timer operation will become unstable when returning from SLEEP status. Therefore, when shifting to SLEEP status, set the clock timer to STOP status (SWRUN = "0") prior to executing the SLP instruction.

**Programmable Timer**

- (1) The programmable timer is actually made to RUN/STOP in synchronization with the falling edge of the input clock after writing to the PRUN0(1) register. Consequently, when "0" is written to the PRUN0(1), the timer shifts to STOP status when the counter is decremented "1". The PRUN0(1) maintains "1" for reading until the timer actually shifts to STOP status. Figure C.3 shows the timing chart of the RUN/STOP control.

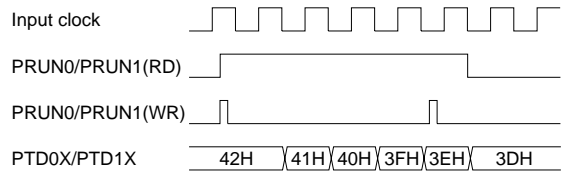

Fig. C.3 Timing chart of RUN/STOP control

- The event counter mode is excluded from the above note.
- (2) The SLP instruction is executed when the programmable timer is in the RUN status (PRUN0(1) = "1"). The programmable timer operation will become unstable when returning from SLEEP status. Therefore, when shifting to SLEEP status, set the clock timer to STOP status (PRUN0(1) = "0") prior to executing the SLP instruction. In the same way, disable the TOUT signal (PTOUT = "0") to avoid an unstable clock output to the R27 output port terminal.
  - (3) Since the TOUT signal is generated asynchronously from the register PTOUT, when the signal is turned ON or OFF by the register setting, a hazard of a 1/2 cycle or less is generated.

- (4) When the OSC3 oscillation circuit is made the clock source, it is necessary to turn the OSC3 oscillation ON, prior to using the programmable timer.

From the time the OSC3 oscillation circuit is turning ON until oscillation stabilizes, an interval of several msec to several 10 msec is necessary. Consequently, you should allow an adequate waiting time after turning the OSC3 oscillation circuit ON before starting the count of the programmable timer. (The oscillation start time will vary somewhat depending on the oscillator and on external parts. Refer to the oscillation start time example indicated in Chapter 7/Technical Hardware, "ELECTRICAL CHARACTERISTICS".)

At initial reset, OSC3 oscillation circuit is set to OFF status.

- (5) When the 16-bit mode has been selected, be sure to read the counter data in the order of PTD00–PTD07 and PTD10–PTD17. Moreover, the time interval between reading PTD00–PTD07 and PTD10–PTD17 should be 0.73 msec or less.

### **LCD Controller**

- (1) Since the CL and FR signals are generated asynchronously from the output control registers LCCLK and LCFRM, when the signals is turned ON or OFF by setting of the registers LCCLK and LCFRM, a hazard of a 1/2 cycle or less is generated.
- (2) When the SLP instruction is executed, display control registers LCDC0 and LCDC1 are automatically reset to "0" by hardware. Furthermore, in the SLEEP status, HIGH (V<sub>DD</sub>) level is output for the CL and FR signals. (When registers R25D and R26D are set to "1".)

### **Sound Generator**

- (1) Since the BZ signal is generated asynchronously from the register BZON, when the signal is turned ON or OFF by the register setting, a hazard of a 1/2 cycle or less is generated.
- (2) The SLP instruction has executed when the BZ signal is in the enable status (BZON = "1" or BZSHT = "1"), an unstable clock is output from the R50 output port terminal at the time of return from the SLEEP status. Consequently, when shifting to the SLEEP status, you should set the BZ signal to the disable status (BZON = BZSHT = "0") prior to executing the SLP instruction.
- (3) The one-shot output is only valid when the normal buzzer output is OFF (BZON = "0") status. The trigger is invalid during ON (BZON = "1") status.

### **Analog Comparator**

- (1) To reduce current consumption, turn the analog comparator OFF (CMP0ON = CMP1ON = "0") when it is not necessary.
- (2) After the analog comparator has been turned ON, a maximum time of 3 msec is necessary until output stabilizes. Consequently, you should allow an adequate waiting time after turning the analog comparator ON, before reading the comparison result.
- (3) Since the input terminals of the analog comparator are common to the I/O ports, the I/O control registers (IOC14–IOC17) corresponding to the channel to be used must be set to the input mode.

### **SVD (Supply Voltage Detection) Circuit**

- (1) To reduce current consumption, turn the SVD circuit OFF (SVDON = SVDSP = "0") when it is not necessary.
- (2) When executing an SLP instruction while the SVD circuit is operating, the stop operation of the OSC1 oscillation circuit is kept waiting until the sampling is completed. The two bits of SVDON and SVDSP are automatically reset to "0" by hardware while waiting for completion of sampling.

### **Interrupt (Exception) Processing**

- (1) When executing the RETE instruction without resetting the interrupt factor flag after an interrupt has been generated, the same interrupt will be generated. Consequently, the interrupt factor flag corresponding to that routine must be reset (writing "1") in the interrupt processing routine.
- (2) Beware. If the interrupt flags (I0 and I1) have been rewritten (set to lower priority) prior to resetting an interrupt factor flag after an interrupt has been generated, the same interrupt will be generated again.
- (3) An exception processing vector is fixed at 2 bytes, so it cannot specify a branch destination bank address. Consequently, to branch from multiple banks to a common exception processing routine, the front portion of an exception processing routine must be described within the common area (000000H–007FFFH).



# EPSON International Sales Operations

---

## AMERICA

---

### EPSON ELECTRONICS AMERICA, INC.

#### - HEADQUARTERS -

1960 E. Grand Avenue  
El Segundo, CA 90245, U.S.A.  
Phone: +1-310-955-5300 Fax: +1-310-955-5400

#### - SALES OFFICES -

##### West

150 River Oaks Parkway  
San Jose, CA 95134, U.S.A.  
Phone: +1-408-922-0200 Fax: +1-408-922-0238

##### Central

101 Virginia Street, Suite 290  
Crystal Lake, IL 60014, U.S.A.  
Phone: +1-815-455-7630 Fax: +1-815-455-7633

##### Northeast

301 Edgewater Place, Suite 120  
Wakefield, MA 01880, U.S.A.  
Phone: +1-781-246-3600 Fax: +1-781-246-5443

##### Southeast

3010 Royal Blvd. South, Suite 170  
Alpharetta, GA 30005, U.S.A.  
Phone: +1-877-EEA-0020 Fax: +1-770-777-2637

## EUROPE

---

### EPSON EUROPE ELECTRONICS GmbH

#### - HEADQUARTERS -

Riesstrasse 15  
80992 Munich, GERMANY  
Phone: +49-(0)89-14005-0 Fax: +49-(0)89-14005-110

#### - GERMANY -

##### SALES OFFICE

Altstadtstrasse 176  
51379 Leverkusen, GERMANY  
Phone: +49-(0)2171-5045-0 Fax: +49-(0)2171-5045-10

#### - UNITED KINGDOM -

##### UK BRANCH OFFICE

Unit 2.4, Doncastle House, Doncastle Road  
Bracknell, Berkshire RG12 8PE, ENGLAND  
Phone: +44-(0)1344-381700 Fax: +44-(0)1344-381701

#### - FRANCE -

##### FRENCH BRANCH OFFICE

1 Avenue de l'Atlantique, LP 915 Les Conquerants  
Z.A. de Courtaboeuf 2, F-91976 Les Ulis Cedex, FRANCE  
Phone: +33-(0)1-64862350 Fax: +33-(0)1-64862355

## ASIA

---

#### - CHINA -

##### EPSON (CHINA) CO., LTD.

28F, Beijing Silver Tower 2# North RD DongSanHuan  
ChaoYang District, Beijing, CHINA  
Phone: 64106655 Fax: 64107319

##### SHANGHAI BRANCH

4F, Bldg., 27, No. 69, Gui Jing Road  
Caohejing, Shanghai, CHINA  
Phone: 21-6485-5552 Fax: 21-6485-0775

#### - HONG KONG, CHINA -

##### EPSON HONG KONG LTD.

20/F., Harbour Centre, 25 Harbour Road  
Wanchai, HONG KONG  
Phone: +852-2585-4600 Fax: +852-2827-4346  
Telex: 65542 EPSCO HX

#### - TAIWAN -

##### EPSON TAIWAN TECHNOLOGY & TRADING LTD.

10F, No. 287, Nanking East Road, Sec. 3  
Taipei, TAIWAN  
Phone: 02-2717-7360 Fax: 02-2712-9164  
Telex: 24444 EPSONTB

##### HsinCHU OFFICE

13F-3, No. 295, Kuang-Fu Road, Sec. 2  
HsinChu 300, TAIWAN  
Phone: 03-573-9900 Fax: 03-573-9169

#### - SINGAPORE -

##### EPSON SINGAPORE PTE., LTD.

No. 1 Temasek Avenue, #36-00  
Millenia Tower, SINGAPORE 039192  
Phone: +65-337-7911 Fax: +65-334-2716

#### - KOREA -

##### SEIKO EPSON CORPORATION KOREA OFFICE

50F, KLI 63 Bldg., 60 Yoido-dong  
Youngdeungpo-Ku, Seoul, 150-763, KOREA  
Phone: 02-784-6027 Fax: 02-767-3677

#### - JAPAN -

##### SEIKO EPSON CORPORATION

##### ELECTRONIC DEVICES MARKETING DIVISION

##### Electronic Device Marketing Department

##### IC Marketing & Engineering Group

421-8, Hino, Hino-shi, Tokyo 191-8501, JAPAN  
Phone: +81-(0)42-587-5816 Fax: +81-(0)42-587-5624

##### ED International Marketing Department Europe & U.S.A.

421-8, Hino, Hino-shi, Tokyo 191-8501, JAPAN  
Phone: +81-(0)42-587-5812 Fax: +81-(0)42-587-5564

##### ED International Marketing Department Asia

421-8, Hino, Hino-shi, Tokyo 191-8501, JAPAN  
Phone: +81-(0)42-587-5814 Fax: +81-(0)42-587-5110



In pursuit of "**Saving**" **Technology**, Epson electronic devices.  
Our lineup of semiconductors, liquid crystal displays and quartz devices  
assists in creating the products of our customers' dreams.  
**Epson IS energy savings.**

**EPSON**

---

**SEIKO EPSON CORPORATION**  
**ELECTRONIC DEVICES MARKETING DIVISION**

■ EPSON Electronic Devices Website  
<http://www.epson.co.jp/device/>

Issue JUNE 1999, Printed in Japan  B