

# **SCI7630 series** **POWER SUPPLY IC**

4.

DC/DC Switching Regulators

The SCI7630 series of CMOS switching regulators comprises nine series—the SCI7631, SCI7638 series

featuring built-in RC oscillators, the SCI7633 series requiring external crystal oscillators.

## SCI7631, SCI7638 Series CMOS Switching Regulators

### DESCRIPTION

The SCI7631, SCI7638 series of CMOS switching regulators provide input voltage step-up and regulation to a specified fixed voltage using an external coil. The devices in these series incorporate precision, low-power reference voltage generators and transistors for driving an internal comparator. They feature low power consumption, low operating voltages, voltage detection and standby operation.

The devices offer a range of fixed output voltages, from 2.0 to 5.0V. The SCI7631 series features battery backup and power-on clear, the SCI7638 series features power-on clear and response compensation, the SCI7638 series offer an output voltage temperature characteristic for driving an LCD. They are available in 8-pin SOP3s.

### FEATURES

- 0.9V (Min.) operating voltage
- 10 $\mu$ A (Typ.) maximum current consumption
- Standby operation
- 3 $\mu$ A (Typ.) standby current consumption
- 1.05  $\pm$ 0.05V high-accuracy voltage detection
- Battery backup (available on SCI7631 series)
- On-chip RC oscillator
- Power-on clear (available on SCI7631 and SCI7638 series)
- Output voltage temperature characteristic for driving an LCD (available on SCI7638 series)
- 8-pin SOP3

### APPLICATIONS

- Fixed-voltage power supplies for battery-operated equipment such as portable video cassette recorders, video cameras and radios
- Power supplies for pagers, memory cards, calculators and similar hand-held equipment
- Fixed-voltage power supplies for medical equipment
- Fixed-voltage power supplies for communications equipment
- Power supplies for microcomputers
- Uninterruptable power supplies
- LCD panel supplies

### LINE-UP

Device	Voltage (V)		Multiplication frequency source	Voltage detection	Power-on clear	Battery backup	Response compensation	Output voltage temperature characteristic	Package
	Input	Output							
SCI7631MLA	1.5 (0.9 min.)	2.4	On-chip RC oscillator	Yes	Yes	Yes	No	No	SOP3-8pin
SCI7631MBA		3.0							SOP3-8pin
SCI7631MKA		3.5							SOP3-8pin
SCI7631MAA		5.0							SOP3-8pin
SCI7638MHA	1.5 (0.9 min.)	2.2	On-chip RC oscillator			No	Yes	-4.5 mV/°C	SOP3-8pin
SCI7638MLA		2.4						-4.0 mV/°C	SOP3-8pin

**BLOCK DIAGRAMS**  
SCI7631 Series

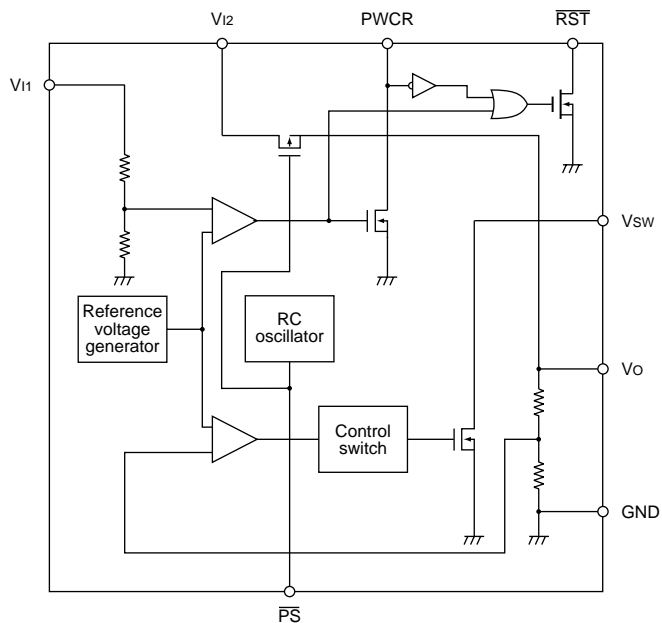

**SCI7638 Series**

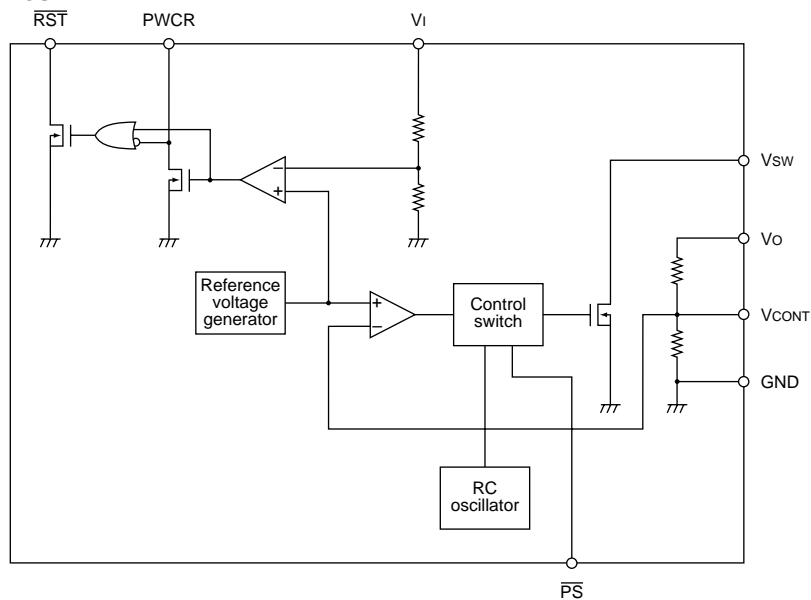

## PIN CONFIGURATIONS

### SCI7631 Series

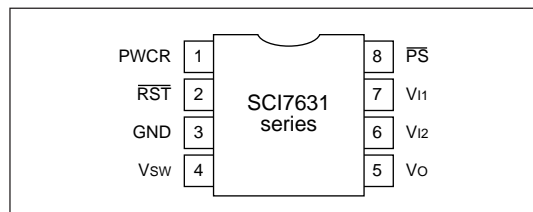

### SCI7638 Series

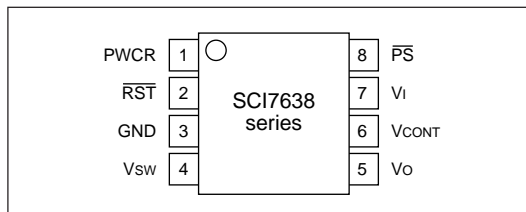

## PIN DESCRIPTIONS

### SCI7631 Series

Number	Name	Description
1	PWCR	Power-on clear. See note 1.
2	$\overline{\text{RST}}$	Reset signal output. See note 1.
3	GND	Ground
4	Vsw	External inductor drive
5	Vo	Output voltage
6	V12	Backup input voltage
7	V11	Step-up input voltage
8	$\overline{\text{PS}}$	Power save. See note 2.

#### Notes

1. See voltage detection and power-on clear in the functional description.
2. See standby mode and battery backup in the functional description.

### SCI7638 Series

Number	Name	Description
1	PWCR	Power-on clear. See note 1.
2	$\overline{\text{RST}}$	Reset signal output. See note 1.
3	GND	Ground
4	Vsw	External inductor drive
5	Vo	Output voltage
6	VCONT	Comparator input
7	V11	Step-up input voltage
8	$\overline{\text{PS}}$	Power save. See note 2.

#### Notes

1. See voltage detection and power-on clear in the functional description.
2. See standby mode and battery backup in the functional description.

## SPECIFICATIONS

### Absolute Maximum Ratings

#### SCI7631 series

Parameter	Symbol	Rating	Unit
Input voltage	$V_{I1}$	7	V
Output current	$I_o$	100	mA
Output voltage	$V_o$	7	V
Power dissipation	$P_D$	200 (SOP3) 300 (DIP)	mW
Operating temperature range	$T_{opr}$	-30 to 85	°C
Storage temperature range	$T_{stg}$	-65 to 150	°C
Soldering temperature (for 10 s). See note.	$T_{sol}$	260	°C

#### Notes

Temperatures during reflow soldering must remain within the limits set out in LSI Device Precautions. Never use solder dip to mount SCI7000 series power supply devices.

#### SCI7638 series

Parameter	Symbol	Rating	Unit
Input voltage	$V_{I1}$	7	V
Output current	$I_o$	100	mA
Output voltage	$V_o$	7	V
Power dissipation	$P_D$	200 (SOP3) 300 (DIP)	mW
Operating temperature range	$T_{opr}$	-30 to 85	°C
Storage temperature range	$T_{stg}$	-65 to 150	°C
Soldering temperature (for 10 s). See note.	$T_{sol}$	260	°C

Parameter	Symbol	Rating	Unit
Input voltage	$V_I$	7	V
Output voltage	$V_o$	7	V
Power dissipation	$P_D$	250	mW
Operating temperature range	$T_{opr}$	-30 to 85	°C
Storage temperature range	$T_{stg}$	-65 to 150	°C

#### Notes

Temperatures during reflow soldering must remain within the limits set out in LSI Device Precautions. Never use solder dip to mount SCI7000 series power supply devices.

**Electrical Characteristics**

**SCI7631MLA**

V<sub>SS</sub> = 0V, T<sub>a</sub> = 25 °C unless otherwise noted

Parameter	Symbol	Condition	Rating			Unit
			Min.	Typ.	Max.	
Input voltage	V <sub>I1</sub>	V <sub>O</sub> > V <sub>I2</sub>	0.9	—	1.8	V
	V <sub>I2</sub>		0.9	—	1.8	V
Output voltage	V <sub>O</sub>	V <sub>I1</sub> = 1.5V	2.32	2.40	2.48	V
Detection voltage	V <sub>DET</sub>		1.00	1.05	1.10	V
Detection voltage hysteresis ratio	ΔV <sub>DET</sub>		—	5	—	%
Operating current	I <sub>DDO</sub>	V <sub>I1</sub> = 1.5V, I <sub>o</sub> = 1.0mA	—	7	35	μA
Standby current	I <sub>DDS</sub>	V <sub>I1</sub> = 1.5V	—	3	10	μA
Switching transistor ON resistance	R <sub>SWON</sub>	V <sub>I1</sub> = 1.5V, V <sub>O</sub> = 2.4V, V <sub>SW</sub> = 0.2V	—	7	14	Ω
Switching transistor leakage current	I <sub>SWQ</sub>	V <sub>I1</sub> = 1.5V, V <sub>O</sub> = 1.5V, V <sub>SW</sub> = 7.0V	—	—	0.5	μA
Backup switch ON resistance	R <sub>BSON</sub>	V <sub>I1</sub> = 1.0V, V <sub>I2</sub> = 1.5V, I <sub>o</sub> = 1.0mA	—	100	250	Ω
Backup switching leakage current	I <sub>BSQ</sub>	V <sub>I1</sub> = 1.0V, V <sub>O</sub> = 2.4V, V <sub>I2</sub> = 2.0V	—	—	0.1	μA
R $\overline{\text{ST}}$ LOW-level output current	I <sub>oL</sub>	V <sub>I1</sub> = 0.9V, V <sub>bs</sub> = 0.2V	0.05	0.15	—	mA
PS pull-up current	I <sub>IH</sub>	V <sub>I1</sub> = 1.5V	—	—	0.5	μA
Multiplication clock frequency	f <sub>CLK</sub>	V <sub>I1</sub> = 1.5V	25	35	45	kHz

**SCI7631MBA**

V<sub>SS</sub> = 0V, T<sub>a</sub> = 25 °C unless otherwise noted

Parameter	Symbol	Condition	Rating			Unit
			Min.	Typ.	Max.	
Input voltage	V <sub>I1</sub>	V <sub>O</sub> > V <sub>I2</sub>	0.9	—	2.0	V
	V <sub>I2</sub>		0.9	—	2.0	V
Output voltage	V <sub>O</sub>	V <sub>I1</sub> = 1.5V	2.90	3.00	3.10	V
Detection voltage	V <sub>DET</sub>		1.00	1.05	1.10	V
Detection voltage hysteresis ratio	ΔV <sub>DET</sub>		—	5	—	%
Operating current	I <sub>DDO</sub>	V <sub>I1</sub> = 1.5V, I <sub>o</sub> = 1.0mA	—	8	40	μA
Standby current	I <sub>DDS</sub>	V <sub>I1</sub> = 1.5V	—	3	10	μA
Switching transistor ON resistance	R <sub>SWON</sub>	V <sub>I1</sub> = 1.5V, V <sub>O</sub> = 3.0V, V <sub>SW</sub> = 0.2V	—	6	12	Ω
Switching transistor leakage current	I <sub>SWQ</sub>	V <sub>I1</sub> = 1.5V, V <sub>O</sub> = 1.5V, V <sub>SW</sub> = 7.0V	—	—	0.5	μA
Backup switch ON resistance	R <sub>BSON</sub>	V <sub>I1</sub> = 1.0V, V <sub>I2</sub> = 2.0V, I <sub>o</sub> = 1.0mA	—	70	160	Ω
Backup switching leakage current	I <sub>BSQ</sub>	V <sub>I1</sub> = 1.0V, V <sub>O</sub> = 3.0V, V <sub>I2</sub> = 2.0V	—	—	0.1	μA
R $\overline{\text{ST}}$ LOW-level output current	I <sub>oL</sub>	V <sub>I1</sub> = 0.9V, V <sub>bs</sub> = 0.2V	0.05	0.15	—	mA
PS pull-up current	I <sub>IH</sub>	V <sub>I1</sub> = 1.5V	—	—	0.5	μA
Multiplication clock frequency	f <sub>CLK</sub>	V <sub>I1</sub> = 1.5V	30	40	50	kHz

## SCI7630 Series

### SCI7631MKA

V<sub>SS</sub> = 0V, T<sub>a</sub> = 25 °C unless otherwise noted

Parameter	Symbol	Condition	Rating			Unit
			Min.	Typ.	Max.	
Input voltage	V <sub>I1</sub>	V <sub>O</sub> > V <sub>I2</sub>	0.9	—	2.0	V
	V <sub>I2</sub>		0.9	—	2.0	V
Output voltage	V <sub>O</sub>	V <sub>I1</sub> = 1.5V	3.40	3.50	3.60	V
Detection voltage	V <sub>DET</sub>		1.00	1.05	1.10	V
Detection voltage hysteresis ratio	ΔV <sub>DET</sub>		—	5	—	%
Operating current	I <sub>DDO</sub>	V <sub>I1</sub> = 1.5V, I <sub>O</sub> = 1.0mA	—	8	40	μA
Standby current	I <sub>DDS</sub>	V <sub>I1</sub> = 1.5V	—	3	10	μA
Switching transistor ON resistance	R <sub>SWON</sub>	V <sub>I1</sub> = 1.5V, V <sub>O</sub> = 3.5V, V <sub>SW</sub> = 0.2V	—	6	12	Ω
Switching transistor leakage current	I <sub>SWQ</sub>	V <sub>I1</sub> = 1.5V, V <sub>O</sub> = 1.5V, V <sub>SW</sub> = 7.0V	—	—	0.5	μA
Backup switch ON resistance	R <sub>BSON</sub>	V <sub>I1</sub> = 1.0V, V <sub>I2</sub> = 2.0V, I <sub>O</sub> = 1.0mA	—	70	160	Ω
Backup switching leakage current	I <sub>BSQ</sub>	V <sub>I1</sub> = 1.0V, V <sub>O</sub> = 3.5V, V <sub>I2</sub> = 2.0V	—	—	0.1	μA
R <sub>ST</sub> LOW-level output current	I <sub>OL</sub>	V <sub>I1</sub> = 0.9V, V <sub>DS</sub> = 0.2V	0.05	0.15	—	mA
PS pull-up current	I <sub>IH</sub>	V <sub>I1</sub> = 1.5V	—	—	0.5	μA
Multiplication clock frequency	f <sub>CLK</sub>	V <sub>I1</sub> = 1.5V	30	40	50	kHz

### SCI7631MAA

V<sub>SS</sub> = 0V, T<sub>a</sub> = 25 °C unless otherwise noted

Parameter	Symbol	Condition	Rating			Unit
			Min.	Typ.	Max.	
Input voltage	V <sub>I1</sub>	V <sub>O</sub> > V <sub>I2</sub>	0.9	—	2.0	V
	V <sub>I2</sub>		0.9	—	2.0	V
Output voltage	V <sub>O</sub>	V <sub>I1</sub> = 1.5V	4.80	5.00	5.20	V
Detection voltage	V <sub>DET</sub>		1.00	1.05	1.10	V
Detection voltage hysteresis ratio	ΔV <sub>DET</sub>		—	5	—	%
Operating current	I <sub>DDO</sub>	V <sub>I1</sub> = 1.5V, I <sub>O</sub> = 1.0mA	—	10	50	μA
Standby current	I <sub>DDS</sub>	V <sub>I1</sub> = 1.5V	—	3	10	μA
Switching transistor ON resistance	R <sub>SWON</sub>	V <sub>I1</sub> = 1.5V, V <sub>O</sub> = 5.0V, V <sub>SW</sub> = 0.2V	—	5	10	Ω
Switching transistor leakage current	I <sub>SWQ</sub>	V <sub>I1</sub> = 1.5V, V <sub>O</sub> = 1.5V, V <sub>SW</sub> = 7.0V	—	—	0.5	μA
Backup switch ON resistance	R <sub>BSON</sub>	V <sub>I1</sub> = 1.0V, V <sub>I2</sub> = 3.0V, I <sub>O</sub> = 1.0mA	—	50	100	Ω
Backup switching leakage current	I <sub>BSQ</sub>	V <sub>I1</sub> = 1.0V, V <sub>O</sub> = 5.0V, V <sub>I2</sub> = 3.0V	—	—	0.1	μA
R <sub>ST</sub> LOW-level output current	I <sub>OL</sub>	V <sub>I1</sub> = 0.9V, V <sub>DS</sub> = 0.2V	0.05	0.15	—	mA
PS pull-up current	I <sub>IH</sub>	V <sub>I1</sub> = 1.5V	—	—	0.5	μA
Multiplication clock frequency	f <sub>CLK</sub>	V <sub>I1</sub> = 1.5V	35	45	55	kHz

**SCI7638MHA**V<sub>SS</sub> = 0V, T<sub>a</sub> = 25 °C unless otherwise noted

Parameter	Symbol	Condition	Rating			Unit
			Min.	Typ.	Max.	
Input voltage	V <sub>I1</sub>		0.9	—	2.0	V
Output voltage	V <sub>O</sub>	V <sub>I1</sub> = 1.5V	2.10	2.20	2.30	V
Output voltage temperature gradient	K <sub>t</sub>		-5.5	-4.5	-3.5	mV/°C
Detection voltage	V <sub>DET</sub>		1.00	1.05	1.10	V
Detection voltage hysteresis ratio	ΔV <sub>DET</sub>		—	5	—	%
Operating current	I <sub>DDO</sub>	V <sub>I1</sub> = 1.5V, I <sub>o</sub> = 1.0mA	—	7	35	μA
Standby current	I <sub>DDS</sub>	V <sub>I1</sub> = 1.5V	—	3	10	μA
Switching transistor ON resistance	R <sub>SWON</sub>	V <sub>I1</sub> = 1.5V, V <sub>O</sub> = 2.2V, V <sub>SW</sub> = 0.2V	—	7	14	Ω
Switching transistor leakage current	I <sub>SWQ</sub>	V <sub>I1</sub> = 1.5V, V <sub>O</sub> = 1.5V, V <sub>SW</sub> = 7.0V	—	—	0.5	μA
R <sub>ST</sub> LOW-level output current	I <sub>OL</sub>	V <sub>I1</sub> = 0.9V, V <sub>OL</sub> = 0.2V	0.05	0.15	—	mA
PS pull-up current	I <sub>IH</sub>	V <sub>I1</sub> = 1.5V	—	—	0.5	μA
Multiplication clock frequency	f <sub>CLK</sub>	V <sub>I1</sub> = 1.5V	25	35	45	kHz

**SCI7638MLA**V<sub>SS</sub> = 0V, T<sub>a</sub> = 25 °C unless otherwise noted

Parameter	Symbol	Condition	Rating			Unit
			Mmin.	Typ.	Max.	
Input voltage	V <sub>I1</sub>		0.9	—	2.0	V
Output voltage	V <sub>O</sub>	V <sub>I1</sub> = 1.5V	2.30	2.40	2.50	V
Output voltage temperature gradient	K <sub>t</sub>		-5.5	-4.0	-3.5	mV/°C
Detection voltage	V <sub>DET</sub>		1.00	1.05	1.10	V
Detection voltage hysteresis ratio	ΔV <sub>DET</sub>		—	5	—	%
Operating current	I <sub>DDO</sub>	V <sub>I1</sub> = 1.5V, I <sub>o</sub> = 1.0mA	—	7	35	μA
Standby current	I <sub>DDS</sub>	V <sub>I1</sub> = 1.5V	—	3	10	μA
Switching transistor ON resistance	R <sub>SWON</sub>	V <sub>I1</sub> = 1.5V, V <sub>O</sub> = 2.4V, V <sub>SW</sub> = 0.2V	—	7	14	Ω
Switching transistor leakage current	I <sub>SWQ</sub>	V <sub>I1</sub> = 1.5V, V <sub>O</sub> = 1.5V, V <sub>SW</sub> = 7.0V	—	—	0.5	μA
R <sub>ST</sub> LOW-level output current	I <sub>OL</sub>	V <sub>I1</sub> = 0.9V, V <sub>OL</sub> = 0.2V	0.05	0.15	—	mA
PS pull-up current	I <sub>IH</sub>	V <sub>I1</sub> = 1.5V	—	—	0.5	μA
Multiplication clock frequency	f <sub>CLK</sub>	V <sub>I1</sub> = 1.5V	25	35	45	kHz



**Typical Performance Characteristics**  
**Fixed-output voltage temperature characteristic**

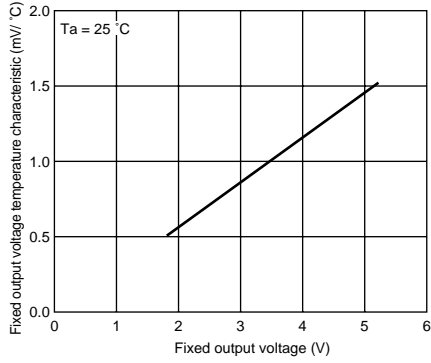

**Standby current vs. ambient temperature characteristic**

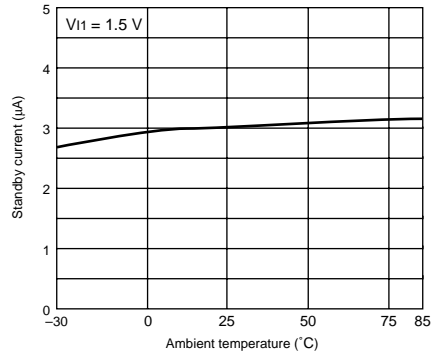

**Detection voltage vs. ambient temperature**

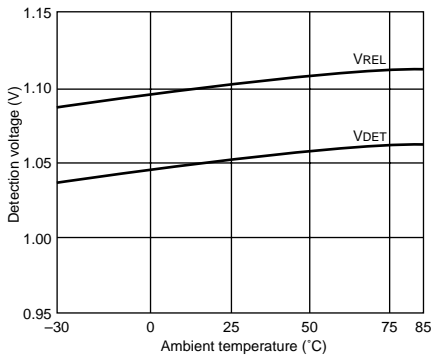

**SCI7638MHA and SCI7638MLA**  
**Clock frequency VS. Input voltage**

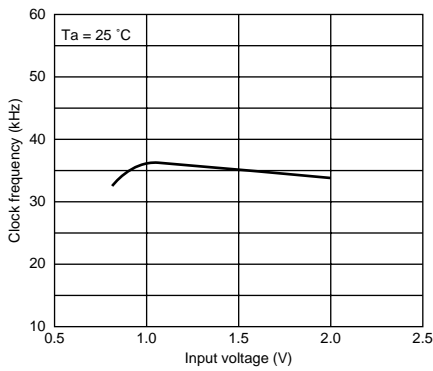

**Clock frequency vs. ambient temperature**

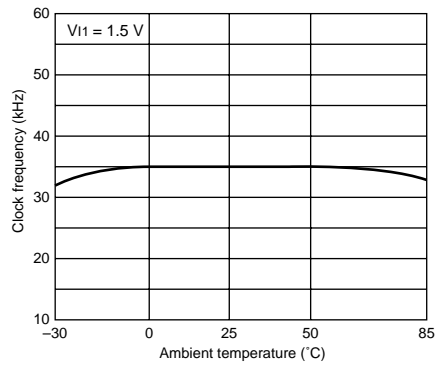

**Output voltage vs. ambient temperature (SCI7638MHA)**

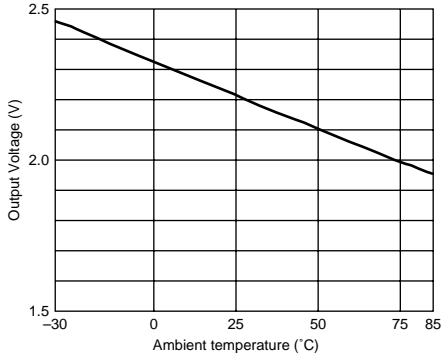

**Output voltage vs. ambient temperature (SCI7638MLA)**

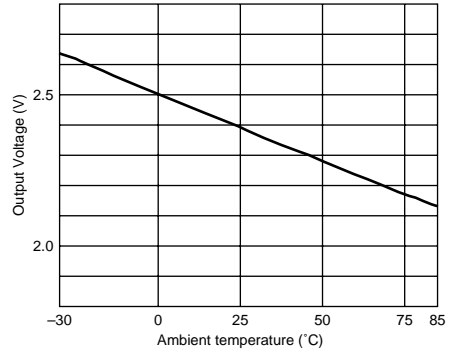

**SCI7631MBA, SCI7631MKA**

**Clock frequency vs. input voltage**

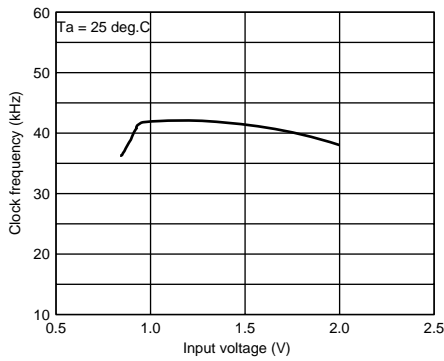

**Clock frequency vs. ambient temperature**

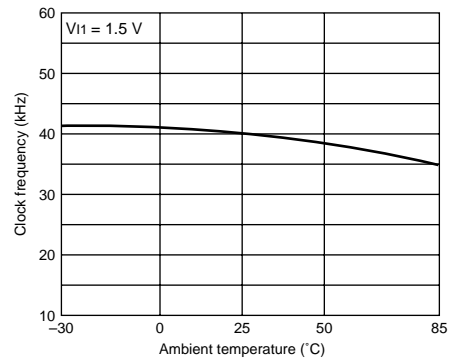

**SCI7631MAA**

**Clock frequency vs. input voltage**

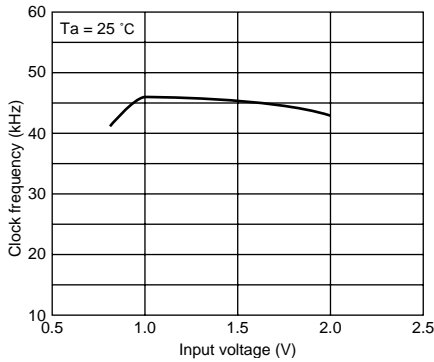

**Clock frequency vs. ambient temperature**

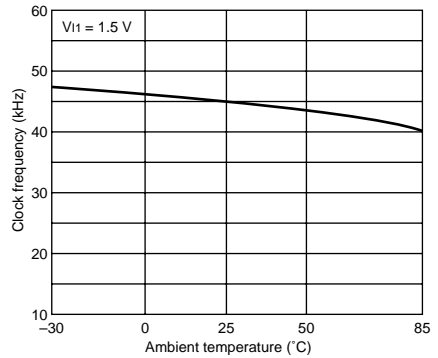

**Load Characteristics**  
**SCI7631MAA**

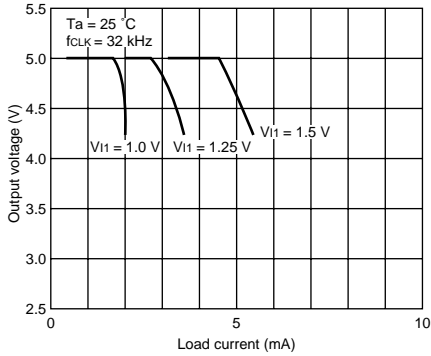

**Notes**

Inductor: TDK NLF453232-221k (220 $\mu$ H)  
 Diode: Shindengen DINS4 Schottky barrier diode  
 Capacitor: NEC MSUB20J106M (10 $\mu$ F)

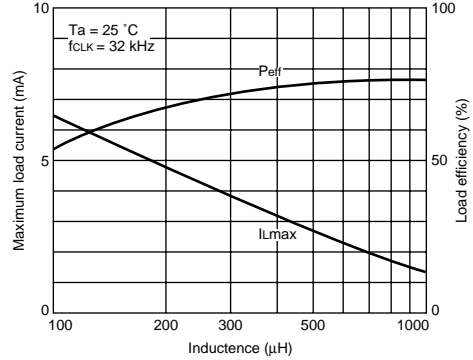

**Notes**

1.  $V_{I1} = 1.5V$
2. Inductor: TDK NLF453232 series  
 Diode: Shindengen DINS4 Schottky barrier diode  
 Capacitor: NEC MSUB20J106M (10 $\mu$ F)

**SCI7631MBA**

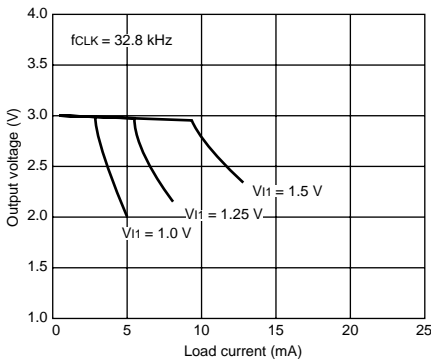

**Notes**

Inductor: TDK NLF453232-221k (220 $\mu$ H)  
 Diode: Shindengen DINS4 Schottky barrier diode  
 Capacitor: NEC MSUB20J106M (10 $\mu$ F)

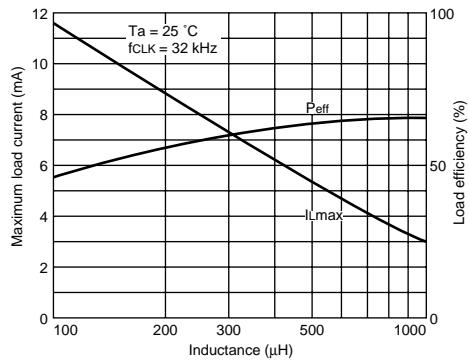

**Notes**

1.  $V_{I1} = 1.5V$
2. Inductor: TDK NLF453232 series  
 Diode: Shindengen DINS4 Schottky barrier diode  
 Capacitor: NEC MSUB20J106M (10 $\mu$ F)

**SCI7638MLA**

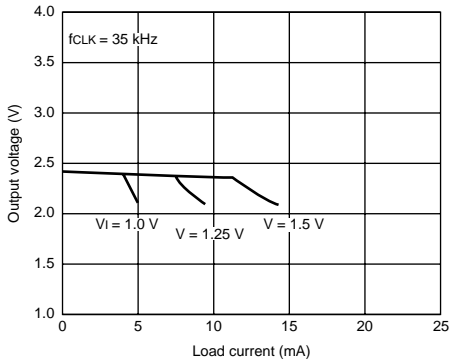

**Notes**

Inductor: TDK NLF453232-221k (220 $\mu$ H)  
 Diode: Shindengen DINS4 Schottky barrier diode  
 Capacitor: NEC MSUB20J106M (10 $\mu$ F)

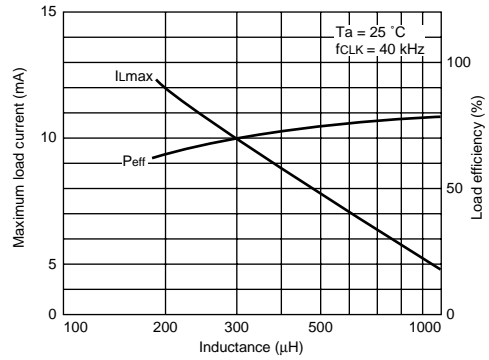

**Notes**

- $V_{I1} = 1.5\text{ V}$
- Inductor: TDK NLF453232 series  
 Diode: Shindengen DINS4 Schottky barrier diode  
 Capacitor: NEC MSUB20J106M (10 $\mu$ F)

**SCI7638MHA**

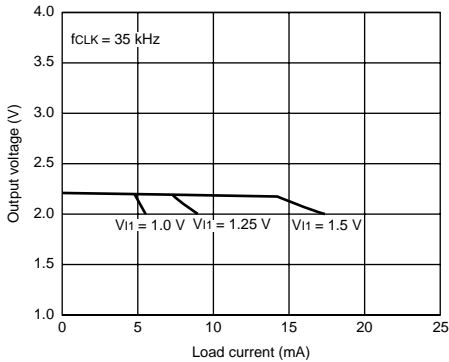

**Notes**

Inductor: TDK NLF453232-221k (220 $\mu$ H)  
 Diode: Shindengen DINS4 Schottky barrier diode  
 Capacitor: NEC MSUB20J106M (10 $\mu$ F)

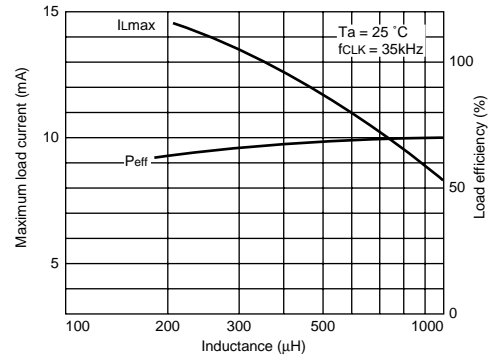

**Notes**

- $V_{I1} = 1.5\text{ V}$
- Inductor: TDK NLF453232 series  
 Diode: Shindengen DINS4 Schottky barrier diode  
 Capacitor: NEC MSUB20J106M (10 $\mu$ F)

**Reset delays**  
**SCI7631MAA**

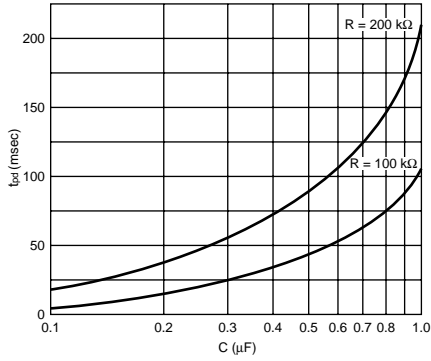

**SCI7631MkA**

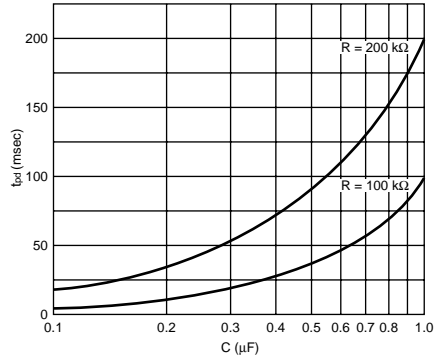

**SCI7631MBA**

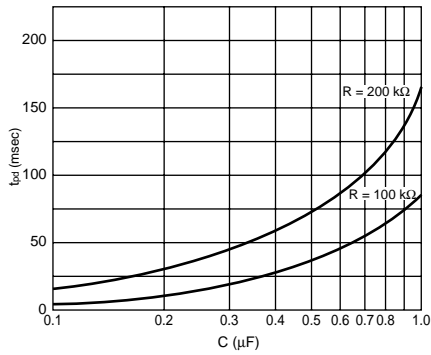

**SCI7631MLA and SCI7638MLA**

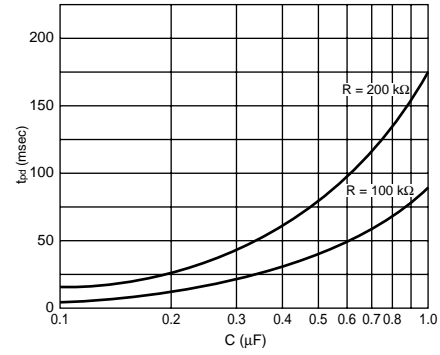

**SCI7638MHA**

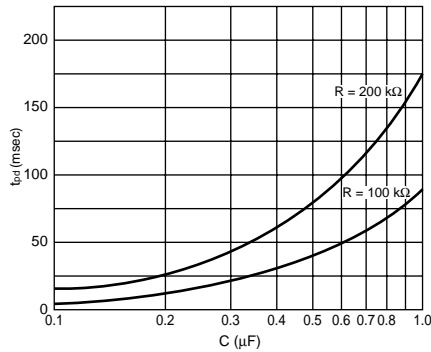

**Timing diagram**

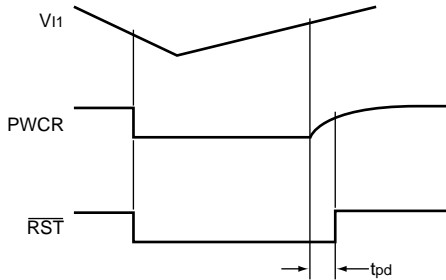

**Measurement circuit**

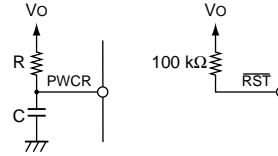

**PACKAGE MARKINGS**

SCI7631, SCI7638 series device packages use the following markings.

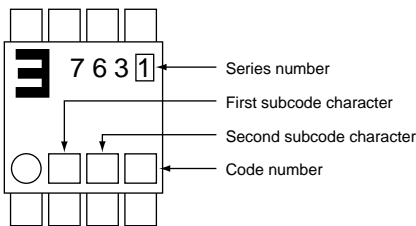

**FUNCTIONAL DESCRIPTION**

**Basic Voltage Booster Operation**

TR1 switches ON and OFF at half the frequency of the clock pulses from the built-in RC oscillator. When the transistor is ON, the circuit stores energy in L. When it is off, this energy flows through D to charge C.

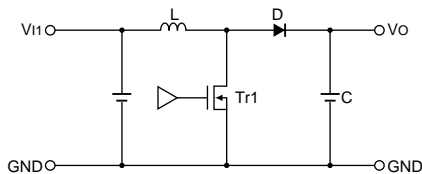

**Internal Circuits**  
**RC oscillator**

The SCI7631, SCI7638 series use a built-in RC oscillator to drive the voltage booster circuit. The circuit is supplied by V11. All circuit components are on-chip and thus the drive frequency is set internally. To ensure 50% duty, this frequency is twice that used by the voltage booster circuit.

When PS is LOW, the oscillator is disabled and the chip is in standby mode.

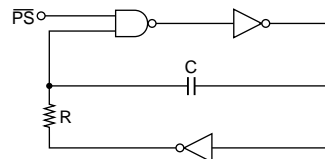

### Reference voltage generator and output voltage regulator

The reference voltage generator regulates  $V_{I1}$  to generate a voltage for the voltage regulator and voltage detection circuits.

The voltage regulator regulates the boosted output voltage. This is determined by the level at point A between the two resistors connecting  $V_O$  and GND. These series use an on-chip resistor to set the output at a specified voltage.

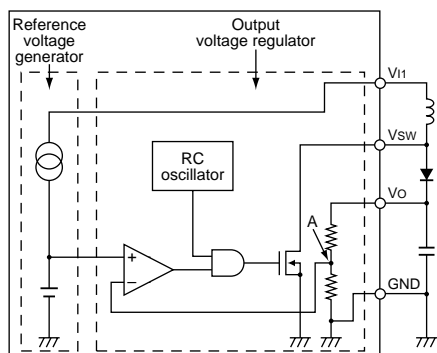

#### Note

In step-up voltage operation, the ripple voltage created by the switching operation is large relative to the output voltage described above. This ripple voltage is affected by external components and load conditions. The user is advised to check this voltage carefully.

### Voltage detection

The SCI7631, SCI7632, SCI7638, and SCI7639 series are equipped with a built-in voltage detection function. The detection voltage,  $V_{DET}$ , is fixed internally at  $1.05 \pm 0.05V$ .

### Power-on clear function

The SCI7631 series and SCI7638 series are equipped with a built-in power-on clear function. As shown in the following figure, R1 and C1 are connected to PWCR, and R2 is connected to  $\overline{RST}$  to operate the function. If  $V_{I1}$  drops below  $V_{DET}$ , TR1 and TR2 conduct and PWCR and  $\overline{RST}$  are grounded. If  $V_{I1}$  recovers and rises higher than  $V_{REL}$ , TR1 turns OFF. The detection voltage hysteresis is 5% (Typ.) and  $V_{REL}$  is  $V_{DET} \times 1.05$  (Typ.).

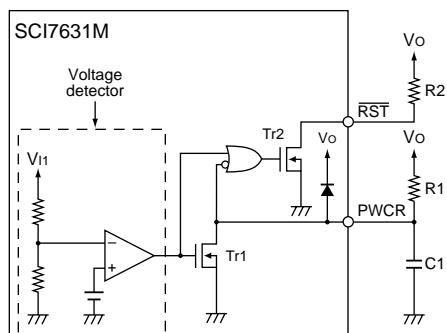

$V_O$  returns to its normal value when the voltage of PWCR increases and TR2 turns OFF, so that  $\overline{RST}$  returns to  $V_O$  after a delay specified by the time coefficient of R1 and C1. Thus, after normal output has been obtained, a reset pulse of adjustable width can be obtained which can reset a system connected to  $\overline{RST}$ . The output from  $\overline{RST}$  is an N-channel, open-drain. When  $V_{I1}$  exceeds  $V_{DET}$ , the drain is opened and, when  $V_{I1}$  drops below  $V_{DET}$  again, the output transistor conducts and the output is grounded. The characteristic response is shown in the following figure.

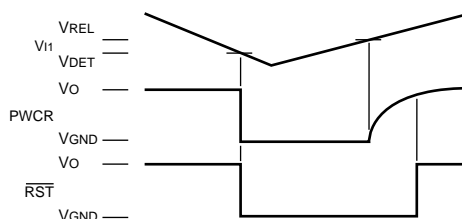

### Disabling power-on clear

Always connect PWCR to either  $V_O$  or GND. If voltage detection only is required, remove the resistor between PWCR and  $V_O$  and monitor the level at  $\overline{RST}$ . If neither function is required, connect PWCR to GND. Leaving PWCR unconnected results in an undefined inverter gate voltage in the  $V_O$  circuit, causing transient currents to flow between  $V_O$  and GND.

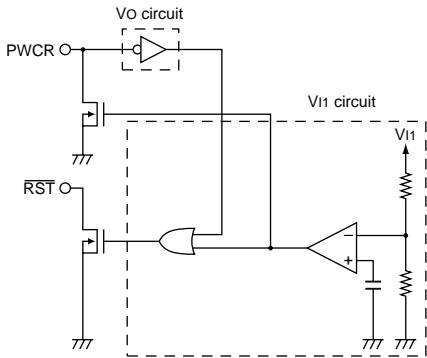

**Output voltage response compensation**

The SCI7638 series are provided with a response compensation input. A response compensation capacitor is connected between VCONT and Vo, allowing the ripple voltage generated by the boosted output voltage to be suppressed to a minimum.

**Standby mode and battery backup**

The SCI7631 series are equipped with a standby mode, initiated by connecting PS to GND.

In standby mode, the booster, including the crystal oscillator, is disabled (the switching transistor used to drive the inductor is turned OFF) and the built-in backup switch is turned ON, so that the input voltage at V12 is output at Vo. This enables the battery backup function. PS is pulled-up internally, so when standby mode is not required, the pin should be left open.

**Powering up**

Ensure that Vo is at least the minimum operating voltage (0.9V) before switching on the booster circuit. One way to do this is to attach a battery so that Vo never drops below the minimum required for backup mode. If no such external power supply is available, connect V12 to V11 and hold PS LOW when applying power for the first time.

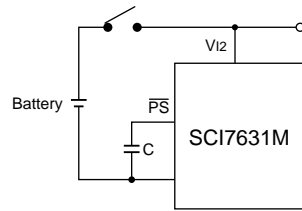

**TYPICAL APPLICATIONS**

**Example Circuits**

The output current, IO, and power conversion efficiency, Peff of a particular device in a series depends on

factors such as the switching frequency, type of coil, and the size and type of other external components.

**SCI7631 series**

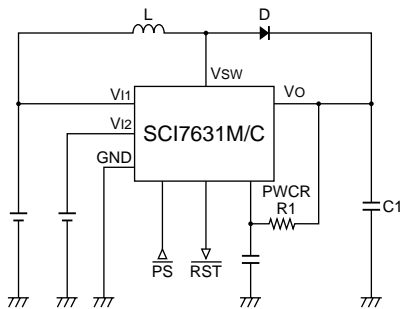

**SCI7638 series**

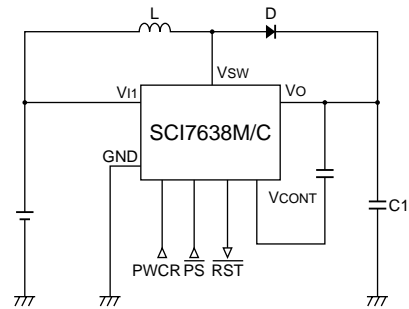



### Notes

■  $100\mu\text{H} \leq L \leq 1\text{mH}$ ,  $C \leq 10\mu\text{F}$ ,  $D = \text{Schottky diode}$

■ SCI7631MAA

- $\text{Peff} = 70\%$  when  $L = 220\mu\text{H}$  (leadless inductor),  
 $V_{\text{II}} = 1.5\text{V}$ ,  $f_{\text{CLK}} = 32\text{kHz}$ ,  $I_{\text{O}} = 4\text{mA}$
- $\text{Peff} = 75\%$  when  $L = 220\mu\text{H}$  (drum coil),  
 $V_{\text{II}} = 1.5\text{V}$ ,  $f_{\text{CLK}} = 32\text{kHz}$ ,  $I_{\text{O}} = 6\text{mA}$
- $\text{Peff} = 80\%$  when  $L = 300\mu\text{H}$  (toroidal coil),  
 $V_{\text{II}} = 1.5\text{V}$ ,  $f_{\text{CLK}} = 32\text{kHz}$ ,  $I_{\text{O}} = 7\text{mA}$

■ SCI7631MBA

- $\text{Peff} = 70\%$  when  $L = 220\mu\text{H}$  (leadless inductor),  
 $V_{\text{II}} = 1.5\text{V}$ ,  $f_{\text{CLK}} = 32\text{kHz}$ ,  $I_{\text{O}} = 8\text{mA}$
- $\text{Peff} = 75\%$  when  $L = 220\mu\text{H}$  (drum coil),  
 $V_{\text{II}} = 1.5\text{V}$ ,  $f_{\text{CLK}} = 32\text{kHz}$ ,  $I_{\text{O}} = 9\text{mA}$
- $\text{Peff} = 80\%$  when  $L = 300\mu\text{H}$  (toroidal coil),  
 $V_{\text{II}} = 1.5\text{V}$ ,  $f_{\text{CLK}} = 32\text{kHz}$ ,  $I_{\text{O}} = 10\text{mA}$

### External components

The performance characteristics of switching regulators depend greatly on the choice of external components. Observing the following guidelines will ensure high performance and maximum efficiency.

### Inductor

Use an inductor with low direct-current resistance and low losses.

### Leadless

Pre-wound, leadless inductors using surface-mount technology are the most suitable for portable equipment and other space-critical applications.

### Drum coil

Avoid using drum coils because their magnetic field can induce noise.

### Toroidal coil

Use a toroidal coil to virtually eliminate magnetic field leakage, reduce losses and improve performance.

### Diode

Use a Schottky barrier diode with a high switching speed and low forward voltage drop,  $V_{\text{F}}$ .

### Capacitor

To minimize ripple voltages, use a capacitor with a small equivalent direct-current resistance for smoothing.

Sample External Components

Leadless Inductors

TDK NKF453232 series magnetically shielded leadless inductors

Device	Inductance (μH)	Qmin	LQ frequency (MHz)	Device frequency (MHz-Min.)	DC resistance (Ω-Max.)	Rated current (mA-Max.)
NLF453232-390K	39.0 ±10%	50	2.52	13	1.89	44
NLF453232-470K	47.0 ±10%	50	2.52	12	2.10	41
NLF453232-560K	56.0 ±10%	50	2.52	11	2.34	39
NLF453232-680K	68.0 ±10%	50	2.52	10	2.60	36
NLF453232-820K	82.0 ±10%	50	2.52	10	2.86	34
NLF453232-101K	100.0 ±10%	50	0.796	9	3.25	32
NLF453232-121K	120.0 ±10%	50	0.796	8	3.64	30
NLF453232-151K	150.0 ±10%	50	0.796	7	4.16	28
NLF453232-181K	180.0 ±10%	40	0.796	6	5.72	26
NLF453232-221K	220.0 ±10%	40	0.796	5.5	6.30	24
NLF453232-271K	270.0 ±10%	40	0.796	5	6.90	23
NLF453232-331K	330.0 ±10%	40	0.796	4.5	7.54	23
NLF453232-391K	390.0 ±10%	40	0.796	4	8.20	21
NLF453232-471K	470.0 ±10%	40	0.796	3.8	9.20	19
NLF453232-561K	560.0 ±10%	40	0.796	3.6	10.50	18
NLF453232-681K	680.0 ±10%	40	0.796	3.4	12.00	17
NLF453232-821K	820.0 ±10%	40	0.796	3	13.50	16
NLF453232-102K	1000.0 ±10%	40	0.252	2.5	16.00	15

Switching Regulator

Characteristic response

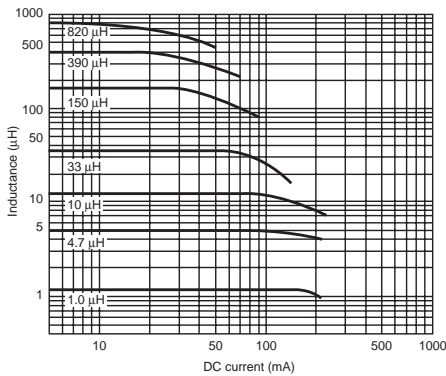

Measurement circuit

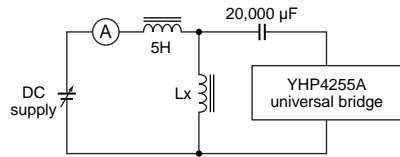

## SCI7630 Series

### Drum coil inductors

Taiyo Yuuden FL series micro-inductors

Device	Inductance	Direct current (mA)
FL3H	0.22 $\mu$ H to 10 $\mu$ H	280 to 670
FL4H	0.47 $\mu$ H to 12 $\mu$ H	300 to 680
FL5H	10 $\mu$ H to 1mH	50 to 320
FL7H	680 $\mu$ H to 8.2mH	50 to 170
FL9H	330 $\mu$ H to 33mH	50 to 500
FL11H	10mH to 150mH	35 to 110

### Toroidal coil inductors

Tohoku Metal Industries HP series toroidal coil inductors

Device	Rated current I <sub>DC</sub> (A)	Inductance ( $\mu$ H) at 20kHz, 5V		Diameter $\times$ height (mm-Max.)	Wire gauge (mm)
		I <sub>DC</sub> = 0	I <sub>DC</sub> = rating		
HP011	1	200	160	$\phi$ 20 $\times$ 12	0.5
HP021	2	65	55		0.7
HP031	3	30	23		0.8
HP012	1	600	450	$\phi$ 22 $\times$ 13	0.5
HP022	2	180	135		0.7
HP032	3	120	80		0.8
HP052	5	45	30		1.0
HP013	1	1000	800	$\phi$ 26 $\times$ 14	0.5
HP023	2	500	330		0.7
HP033	3	130	100		0.8
HP055	5	90	55		1.0
HP034S	3	400	250	$\phi$ 36 $\times$ 18	0.8
HP054S	5	350	160		1.0
HP104S	10	50	30		1.6
HP024	2	1500	950	$\phi$ 36 $\times$ 21	0.7
HP034	3	300	230		0.8
HP054	3	210	140		1.0
HP104	10	45	30		1.6
HP035	3	700	500	$\phi$ 43 $\times$ 23	0.5
HP055	5	600	330		1.0
HP105	10	180	95		1.6
HP205	20	20	14		1.8 $\times$ 2 P

### Diodes

Shindengen DINS4 Schottky barrier diodes

Parameter	Symbol	Condition	Rating			Unit
			Min.	Typ.	Max.	
Forward voltage	$V_F$	$I_F = 1.1A$ , pulse measurement	—	—	0.55	V
Reverse current	$I_R$	$V_R = V_{RM}$ , pulse measurement	—	—	1	mA
Junction-to-lead thermal resistance	$\theta_{jl}$		—	—	23	$^{\circ}C/W$
Junction-to-ambient thermal resistance	$\theta_{ja}$		—	—	157	$^{\circ}C/W$

### Characteristics

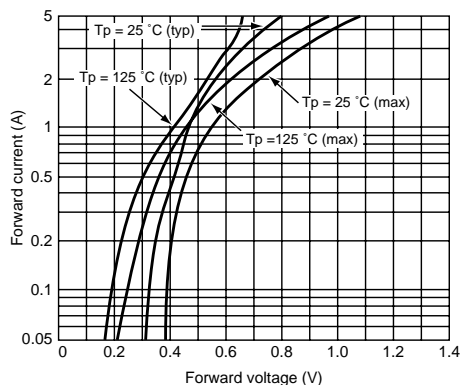

### Smoothing capacitors

NEC MSV series capacitors

Device	Package type	Rated voltage (V)	Static capacitance ( $\mu F$ )	Tan $\delta$			Leakage current ( $\mu A$ )
				+25, +85 $^{\circ}C$	+125 $^{\circ}C$	-55 $^{\circ}C$	
MSVAOJ475M	A	6.3	4.7	0.08	0.1	0.12	0.5
MSVB2OJ106M	B2	6.3	10	0.08	0.1	0.12	0.6
MSVB2OJ156M	B2	6.3	15	0.08	0.1	0.12	0.9
MSVBOJ156M	B	6.3	15	0.08	0.1	0.12	0.9
MSVCOJ336M	C	6.3	33	0.08	0.1	0.12	2.0
MSVD2OJ686M	D2	6.3	68	0.08	0.1	0.12	4.2
MSVDOJ686M	D	6.3	68	0.08	0.1	0.12	4.2

#### Note

The figures on the previous pages show data from the documents of various manufactures. For further details, please contact the relevant manufacture.

**Other Applications**  
**Voltage booster**

Combining an SCI7631 switching regulator with an SCI7661C/M DC/DC converter and voltage regulator

creates the voltage booster circuit shown in the following figure.

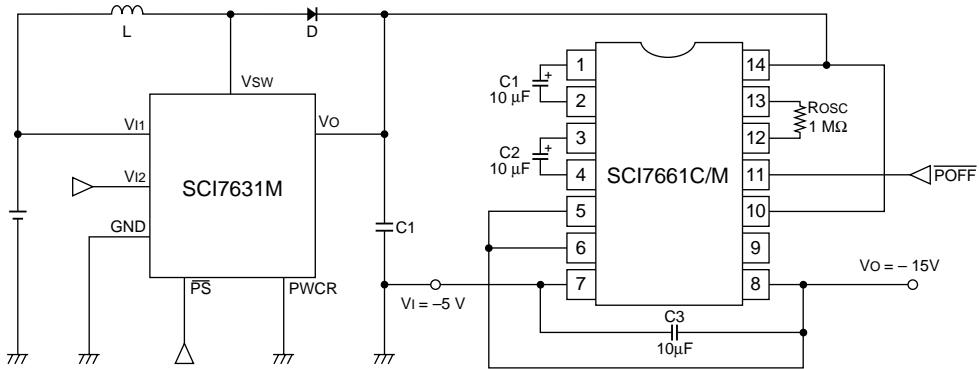

Potential levels are shown in the following figure.

SCI7631MAA. The input voltage still reaches the SCI7661C/M through L and D.

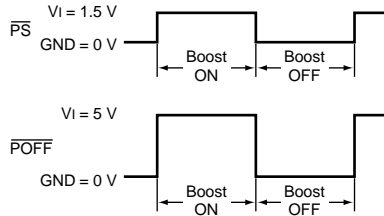
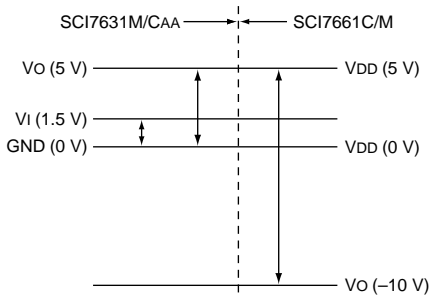

Although the circuit appears to have two ON/OFF control points, PS on the SCI7631CAA/MAA and PPOFF on the SCI7661C/M, PS only shuts down the

### Output voltage adjustment

To ensure stable output, any circuit that adjusts the output voltage must contain C1, RA and RB. To stop switching current from affecting VO, the circuit must also satisfy the condition  $I_O < I_R$ .

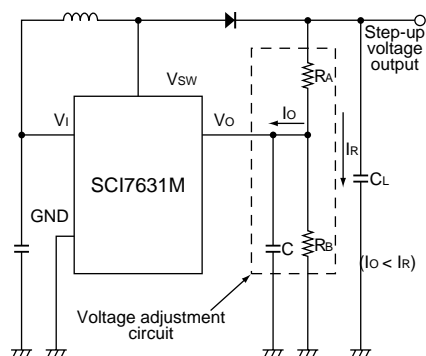

The following figure summarizes the relevant circuits inside an SCI7630 series chip.

VO is connected to the level shift and buffer circuit, which provide the gate bias for the switching transistor driving the inductor. The current drain, IO1, varies with the load and is typically 10µA. The current, IO2, through the internal resistors R1 and R2, is typically 1µA.

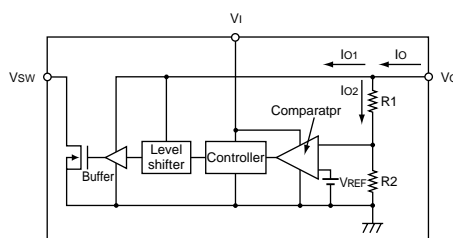

## SCI7633 Series CMOS Switching Regulators

### DESCRIPTION

The SCI7633 series of CMOS switching regulators provide input voltage step-up and regulation to a specified voltage using an external coil. The devices in these series incorporate precision, low-power reference voltage generators and transistors for driving an internal comparator. They feature low power consumption, low operating voltages and standby operation.

The devices offer a range of fixed output voltages, from 2.35 to 5.00V.

They are available in 8-pin SOP3s.

### FEATURES

- 0.9V (Min.) operating voltage
- 8µA (Typ.) maximum current consumption
- Standby operation
- 3µA (Typ.) standby current consumption
- Built-in oscillator circuit for use with external crystal oscillator
- 8-pin SOP3

### APPLICATIONS

- Fixed-voltage power supplies for battery-operated equipment such as portable video cassette recorders, video cameras and radios
- Power supplies for pages, memory cards, calculators and similar hand-held equipment
- Fixed-voltage power supplies for medical equipment
- Fixed-voltage power for communications equipment
- Power supplies for microcomputers
- Uninterruptable power supplies

## SCI7630 Series

### LINE-UP

Device	Voltage (V)		Multiplication frequency source	Voltage detection	Power-on clear	Battery backup	Response compensation	Output voltage temperature characteristic	Package
	Input	Output							
SCI7633MBA	1.5 (0.9 min.)	3.00	Crystal oscillator	No	No	No	No	No	SOP3-8pin

### BLOCK DIAGRAMS SCI7633 series

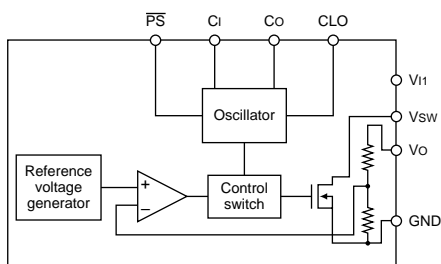

### PIN CONFIGURATIONS SCI7633 series

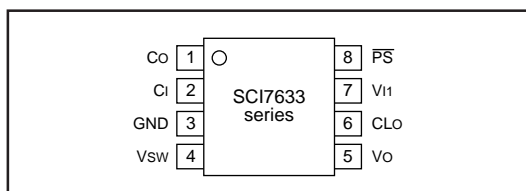

### PIN DESCRIPTIONS SCI7633 series

Number	Name	Description
1	Co	Crystal drain
2	Ci	Crystal gate
3	GND	Ground
4	Vsw	External inductor drive
5	Vo	Output voltage
6	CLO	Oscillator output
7	Vi1	Step-up input voltage
8	PS	Power save. See note.

#### Note

See standby mode in the functional description.

## SPECIFICATIONS

### Absolute Maximum Ratings

#### SCI7633 series

Parameter	Symbol	Rating	Unit
Input voltage	V <sub>I1</sub>	7	V
Output current	I <sub>O</sub>	100	mA
Output voltage	V <sub>O</sub>	7	V
Power dissipation	P <sub>D</sub>	200 (SOP) 300 (DIP)	mW
Operating temperature range	T <sub>opr</sub>	-30 to 85	°C
Storage temperature range	T <sub>stg</sub>	-65 to 150	°C
Soldering temperature (for 10 s. See note.)	T <sub>sol</sub>	260	°C

#### Note

Temperatures during reflow soldering must remain within the limits set out in LSI Device Precautions. Never use solder dip to mount SCI7000 series power supply devices.

## Electrical Characteristics

### SCI7633MBA

V<sub>SS</sub> = 0V, T<sub>a</sub> = 25 °C unless otherwise noted

Parameter	Symbol	Conditions	Rating			Unit
			Min.	Typ.	Max.	
Input voltage	V <sub>I1</sub>	V <sub>O</sub> > V <sub>I2</sub>	0.9	—	2.0	V
Output voltage	V <sub>O</sub>	V <sub>I1</sub> = 1.5V	2.90	3.00	3.10	V
Operating current	I <sub>DDO</sub>	V <sub>I1</sub> = 1.5V, f <sub>CLK</sub> = 32kHz, I <sub>O</sub> = 1.0mA	—	5	30	μA
Standby current	I <sub>DDS</sub>	V <sub>I1</sub> = 1.5V	—	3	10	μA
Switching transistor ON resistance	R <sub>SWON</sub>	V <sub>I1</sub> = 1.5V, V <sub>O</sub> = 3.0V, V <sub>SW</sub> = 0.2V	—	6	12	Ω
Switching transistor leakage current	I <sub>SWQ</sub>	V <sub>I1</sub> = 1.5V, V <sub>O</sub> = 1.5V, V <sub>SW</sub> = 7.0V	—	—	0.5	μA
CLO LOW-level output current	I <sub>OL</sub>	V <sub>I1</sub> = 1.5V, V <sub>O</sub> = 3.0V, V <sub>OL</sub> = 0.2V	0.5	1.0	—	μA
CLO HIGH-level output current	I <sub>OH</sub>	V <sub>I1</sub> = 1.5V, V <sub>O</sub> = 3.0V, V <sub>OH</sub> = 0.2V	0.55	1.1	—	μA
$\overline{\text{PS}}$ pull-up current	I <sub>IH</sub>	V <sub>IH</sub> = 1.5V	—	—	0.5	μA
Oscillator start-up voltage	V <sub>STA</sub>	C <sub>G</sub> = 10pF, C <sub>D</sub> = 10pF, R <sub>D</sub> = 300kΩ,	0.9	—	—	V
Oscillator shut-down voltage	V <sub>STP</sub>	f <sub>osc</sub> = 32kHz	—	—	0.9	V



**Typical Performance Characteristics**  
**Fixed output voltage temperature characteristic**

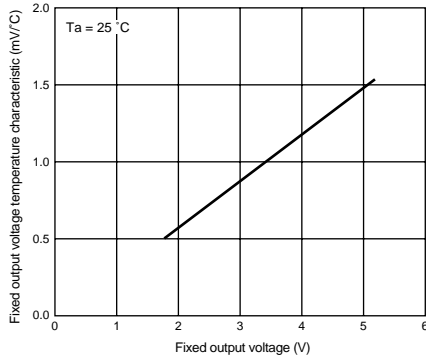

**Normalized frequency deviation vs. gate capacitance 1**

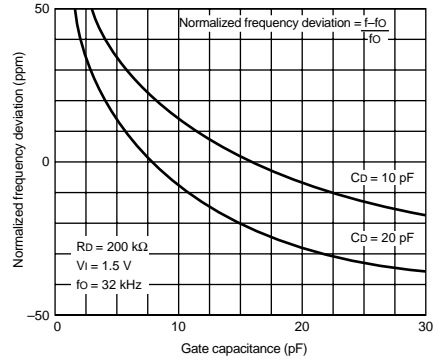

**Standby current vs. ambient temperature**

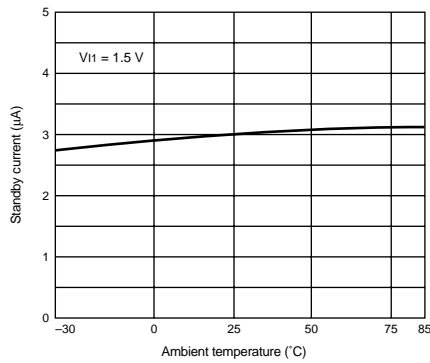

**Normalized frequency deviation vs. input voltage 2**

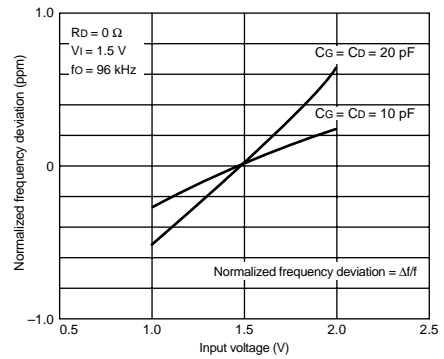

**Normalized frequency deviation vs. input voltage 1**

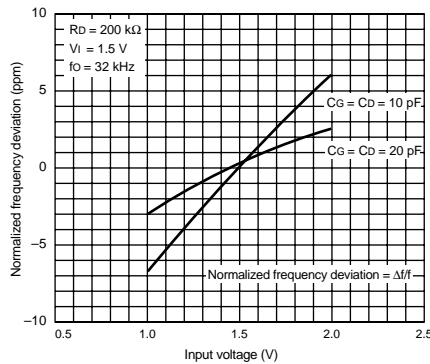

**Normalized frequency deviation vs. gate capacitance 2**

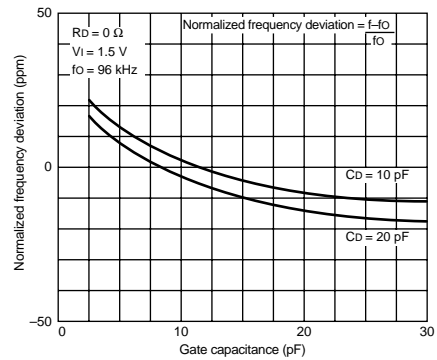

**Load characteristics**  
**SCI7633MBA**

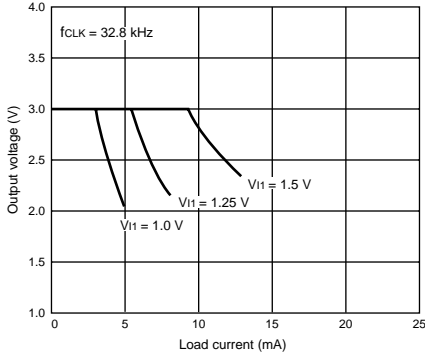

**Notes**

Inductor: TDK NLF453232-221k (220μH)  
 Diode: Shindengen DINS4 Schottky barrier diode  
 Capacitor: NEC MSUB20J106M (10μF)

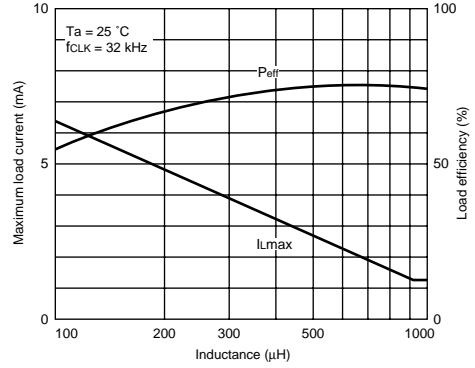

**Notes**

1. V<sub>11</sub> = 1.5V
2. Inductor: TDK NLF453232 series  
 Diode: Shindengen DINS4 Schottky barrier diode  
 Capacitor: NEC MSUB20J106M (10μF)

**PACKAGE MARKINGS**

SCI7633 device packages use the following marking.

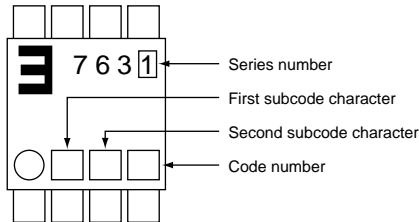

## FUNCTIONAL DESCRIPTION

### Basic Voltage Booster Operation

TR1 switches ON and OFF at the frequency of the clock pulses from the crystal oscillator. When the transistor is ON, the circuit stores energy in L. When it is OFF, this energy flows through D to charge C.

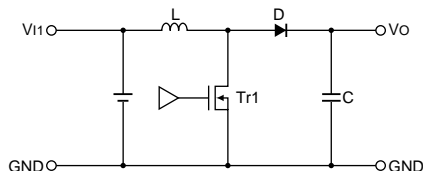

### Internal Circuits

#### Crystal oscillator

The SCI7633 series incorporate a crystal oscillator circuit. An external crystal and drain resistor are used to generate the booster circuit clock. The crystal oscillator is connected to CI and CO as shown in the following figure.

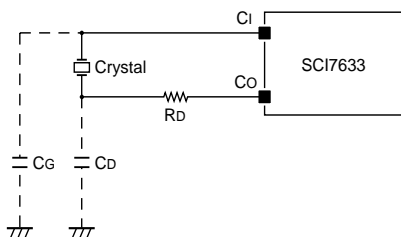

In the SCI7633 series, the crystal oscillator output is sent to CLO as the VO system signal. The crystal oscillator circuit is activated by VI but, because the output level is shifted and the output is connected to CLO, the oscillator output cannot be obtained without a voltage at VO. Since the crystal oscillator is activated when an input voltage is applied, oscillation continues even in standby mode.

#### Reference voltage generator and output voltage regulator

The reference voltage generator regulates V11 to generate a voltage for the voltage regulator circuit.

The output voltage regulator regulates the boosted output voltage. This voltage is determined by the level at point A between the two resistors connecting VO and GND. These series use an on-chip resistor to set the output at a specified voltage.

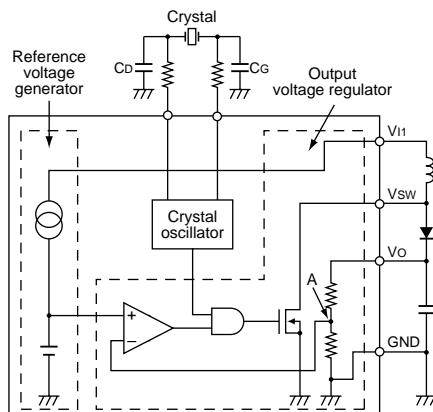

#### Note

In step-up voltage operation, the ripple voltage created by the switching operation is large relative to the output voltage described above. This ripple voltage is affected by external components and load conditions. The user is advised to check this voltage carefully.

#### Standby mode

Connecting  $\overline{PS}$  to GND places the chip in standby mode. In this mode, the crystal oscillator is disabled, switching off the inductor drive transistor and the voltage booster circuit. Typically,  $\overline{PS}$  is connected to  $\overline{RST}$ . If standby mode is not required, leave  $\overline{PS}$  open as it has a pull-up resistor.

#### Output voltage response compensation

The SCI7634 series incorporates a response compensation input. A response compensation capacitor is connected between VCONT and VO, allowing the ripple voltage generated by the boosted output voltage to be suppressed to a minimum.

**Powering up**

Ensure that  $V_O$  is at least the minimum operating voltage (0.9V) before switching on the booster circuit. One way to do this is to connect a capacitor between  $\overline{PS}$  and GND so that the chip connects  $V_O$  to  $V_I$  when the power is applied for the first time.

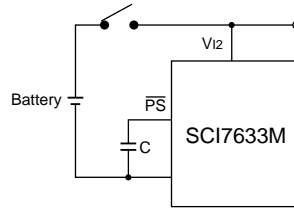

**TYPICAL APPLICATIONS**

**Example Circuits**

The output current,  $I_O$ , and power conversion efficiency  $P_{eff}$ , of a particular device in the series depends on fac-

tors such as the switching frequency, type of coil, and the size and type of other external components.

**SCI7633 series**

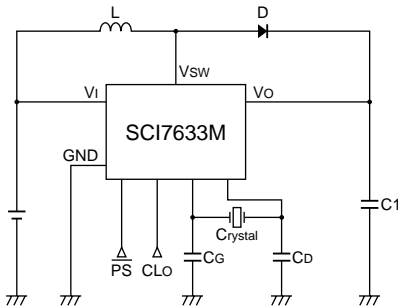

**Notes**

- $100\mu\text{H} \leq L \leq 1\text{mH}$ ,  $C \leq 10\mu\text{F}$ , D: Schottky diode
- SCI7633MBA
  - $P_{eff} = 70\%$  when  $L = 220\mu\text{H}$  (leadless inductor),  $V_{I1} = 1.5\text{V}$ ,  $f_{CLK} = 32\text{kHz}$ ,  $I_O = 8\text{mA}$
  - $P_{eff} = 75\%$  when  $L = 220\mu\text{H}$  (drum coil),  $V_{I1} = 1.5\text{V}$ ,  $f_{CLK} = 32\text{kHz}$ ,  $I_O = 9\text{mA}$
  - $P_{eff} = 80\%$  when  $L = 300\mu\text{H}$  (toroidal coil),  $V_{I1} = 1.5\text{V}$ ,  $f_{CLK} = 32\text{kHz}$ ,  $I_O = 10\text{mA}$

**External Components**

The performance characteristics of switching regulators depend greatly on the choice of external components. Observing the following guidelines will ensure high performance and maximum efficiency.

**Inductor**

Use an inductor with low direct-current resistance and low losses.

**Leadless**

Pre-wound, leadless inductors using surface-mount technology are the most suitable for portable equipment and other space-critical applications.

**Drum coil**

Avoid drum coils because their magnetic field can induce noise.

**Toroidal coil**

Use a toroidal coil to virtually eliminate magnetic field leakage, reduce losses and improve performance.

## SCI7630 Series

### Diode

Use a Schottky barrier diode with a high switching speed and low forward voltage drop,  $V_F$ .

### Capacitor

To minimize ripple voltages, use capacitors with a small equivalent direct-current resistance for smoothing.

## Sample External Components

### Leadless inductors

TDK NLF453232 series magnetically-shielded leadless inductors

Device	Inductance ( $\mu\text{H}$ )	Qmin	LQ frequency (MHz)	Device frequency (MHz-Min.)	DC resistance ( $\Omega$ -Max.)	Rated current (mA-Max.)
NLF453232-390K	39.0 $\pm$ 10%	50	2.52	13	1.89	44
NLF453232-470K	47.0 $\pm$ 10%	50	2.52	12	2.10	41
NLF453232-560K	56.0 $\pm$ 10%	50	2.52	11	2.34	39
NLF453232-680K	68.0 $\pm$ 10%	50	2.52	10	2.60	36
NLF453232-820K	82.0 $\pm$ 10%	50	2.52	10	2.86	34
NLF453232-101K	100.0 $\pm$ 10%	50	0.796	9	3.25	32
NLF453232-121K	120.0 $\pm$ 10%	50	0.796	8	3.64	30
NLF453232-151K	150.0 $\pm$ 10%	50	0.796	7	4.16	28
NLF453232-181K	180.0 $\pm$ 10%	40	0.796	6	5.72	26
NLF453232-221K	220.0 $\pm$ 10%	40	0.796	5.5	6.30	24
NLF453232-271K	270.0 $\pm$ 10%	40	0.796	5	6.90	23
NLF453232-331K	330.0 $\pm$ 10%	40	0.796	4.5	7.54	23
NLF453232-391K	390.0 $\pm$ 10%	40	0.796	4	8.20	21
NLF453232-471K	470.0 $\pm$ 10%	40	0.796	3.8	9.20	19
NLF453232-561K	560.0 $\pm$ 10%	40	0.796	3.6	10.50	18
NLF453232-681K	680.0 $\pm$ 10%	40	0.796	3.4	12.00	17
NLF453232-821K	820.0 $\pm$ 10%	40	0.796	3	13.50	16
NLF453232-102K	1000.0 $\pm$ 10%	40	0.252	2.5	16.00	15

### Characteristic response

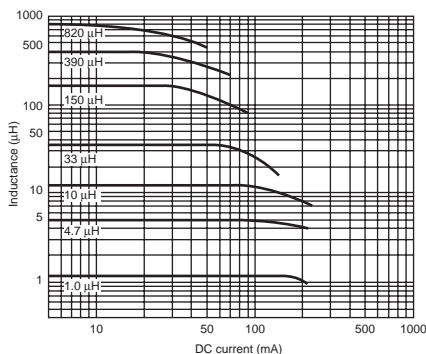

### Measurement circuit

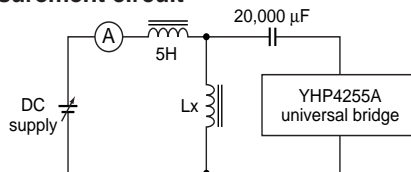

**Drum coil inductors**

Taiyo Yuuden FL series micro inductors

Device	Inductance	Direct current (mA)
FL3H	0.22 $\mu$ H to 10 $\mu$ H	280 to 670
FL4H	0.47 $\mu$ H to 12 $\mu$ H	300 to 680
FL5H	10 $\mu$ H to 1mH	50 to 320
FL7H	680 $\mu$ H to 8.2mH	50 to 170
FL9H	330 $\mu$ H to 33mH	50 to 500
FL11H	10 $\mu$ H to 150mH	35 to 110

**Toroidal coil inductors**

Tohoku Metal Industries HP series toroidal coil inductors

Device	Rated current I <sub>DC</sub> (A)	Inductance ( $\mu$ H) at 20kHz, 5V		Diameter $\times$ height (mm-Max.)	Wire gauge (mm)
		I <sub>DC</sub> = 0	I <sub>DC</sub> = rating		
HP011	1	200	160	20 $\times$ 12	0.5
HP021	2	65	55		0.7
HP031	3	30	23		0.8
HP012	1	600	450	22 $\times$ 13	0.5
HP022	2	180	135		0.7
HP032	3	120	80		0.8
HP052	5	45	30		1.0
HP013	1	1000	800	26 $\times$ 14	0.5
HP023	2	500	330		0.7
HP033	3	130	100		0.8
HP055	5	90	55		1.0
HP034S	3	400	250	36 $\times$ 14	0.8
HP054S	5	350	160		1.0
HP104S	10	50	30		1.6
HP024	2	1500	950	36 $\times$ 21	0.7
HP034	3	300	230		0.8
HP054	5	210	140		1.0
HP104	10	45	30		1.6
HP035	3	700	500	43 $\times$ 23	0.8
HP055	5	600	330		1.0
HP105	10	180	95		1.6
HP205	20	20	14		1.8 $\times$ 2 P

**Diodes**

Shindengen DINS4 Schottky barrier diodes

Parameter	Symbol	Conditions	Rating			Unit
			Min.	Typ.	Max.	
Forward voltage	$V_F$	$I_F = 1.1A$ , pulse measurement	—	—	0.55	V
Reverse current	$I_R$	$V_R = V_{RM}$ , pulse measurement	—	—	1	mA
Junction-to-lead thermal resistance	$\theta_{j\ell}$		—	—	23	$^{\circ}C/W$
Junction-to-ambient thermal resistance	$\theta_{ja}$		—	—	157	$^{\circ}C/W$

**Characteristics**

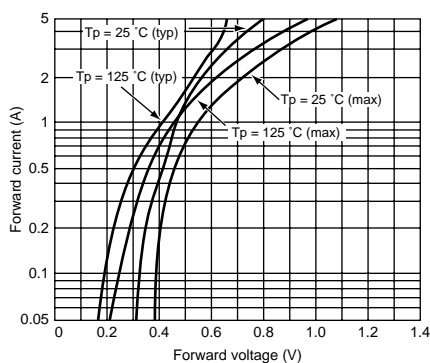

**Smoothing capacitors**

NEC MSV series capacitors

Device	Package type	Voltage (V)	Static capacitance ( $\mu F$ )	Tan $\delta$			Leakage current ( $\mu A$ )
				+25, +85 $^{\circ}C$	+125 $^{\circ}C$	-55 $^{\circ}C$	
MSVA0J475M	A	6.3	4.7	0.08	0.1	0.12	0.5
MSVB20J106M	B2	6.3	10	0.08	0.1	0.12	0.6
MSVB20J156M	B2	6.3	15	0.08	0.1	0.12	0.9
MSVB0J156M	B	6.3	15	0.08	0.1	0.12	0.9
MSVC0J336M	C	6.3	33	0.08	0.1	0.12	2.0
MSVD20J686M	D2	6.3	68	0.08	0.1	0.12	4.2
MSVD0J686M	D	6.3	68	0.08	0.1	0.12	4.2

**Note**

The figures on the previous pages show data from the documents of various manufacturers. For further details, please contact the relevant manufacturer.

### Other Applications

#### Voltage booster

Combining an SCI7633MBA switching regulator with an SCI7661C/M DC/DC converter and voltage regula-

tor creates the voltage booster circuit shown in the following figure.

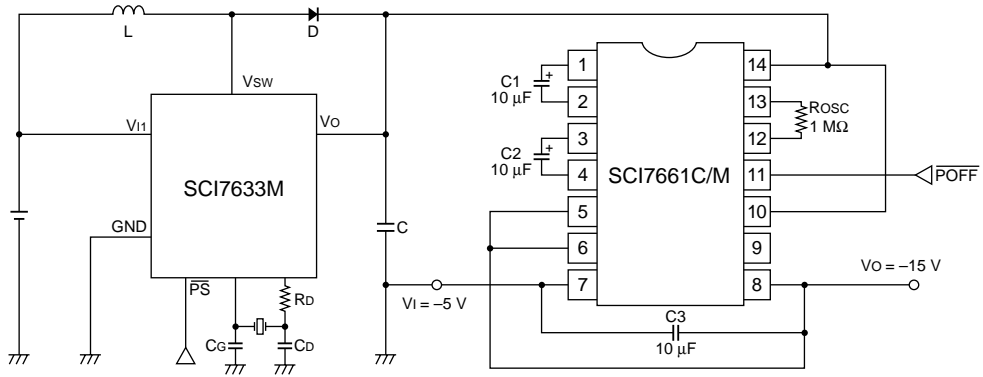

Potential levels are shown in the following figure.

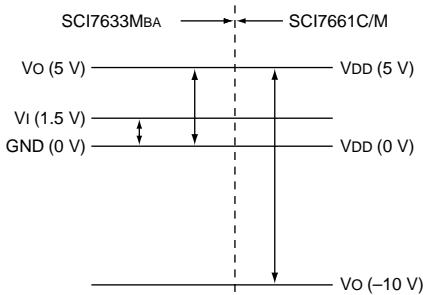

Although the circuit appears to have two ON/OFF control points,  $\overline{PS}$  on the SCI7633MBA and  $\overline{POFF}$  on the SCI7661C/M,  $\overline{PS}$  only shuts down the SCI7633MBA. The input voltage still reaches the SCI7661C/M through L and D.

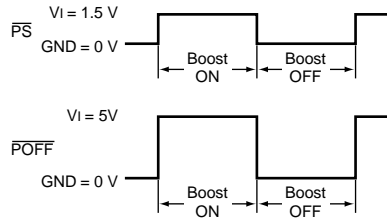



**Output voltage adjustment**

To ensure stable output, any circuit that adjusts the output voltage must contain C1, RA and RB. To stop switching current from affecting VO, the circuit must also satisfy the condition  $I_O < I_R$ .

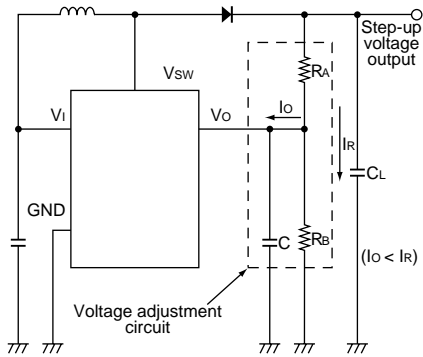

The following figure summarizes the relevant circuits inside an SCI7000 series chip.

V<sub>O</sub> is connected to the level shift and buffer circuit, which provide the gate bias for the switching transistor driving the inductor. The current drain I<sub>O1</sub>, varies with the load and is typically 10μA. The current, I<sub>O2</sub>, through the internal resistors R<sub>1</sub> and R<sub>2</sub> is typically 1μA.

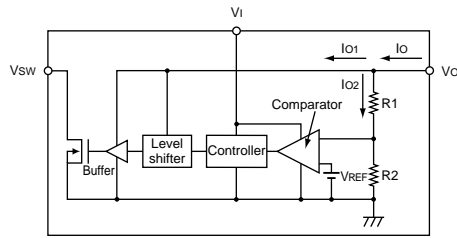

# SCI7720Y series POWER SUPPLY IC

5.

Voltage Detector