

3. SED1743 LCD Driver

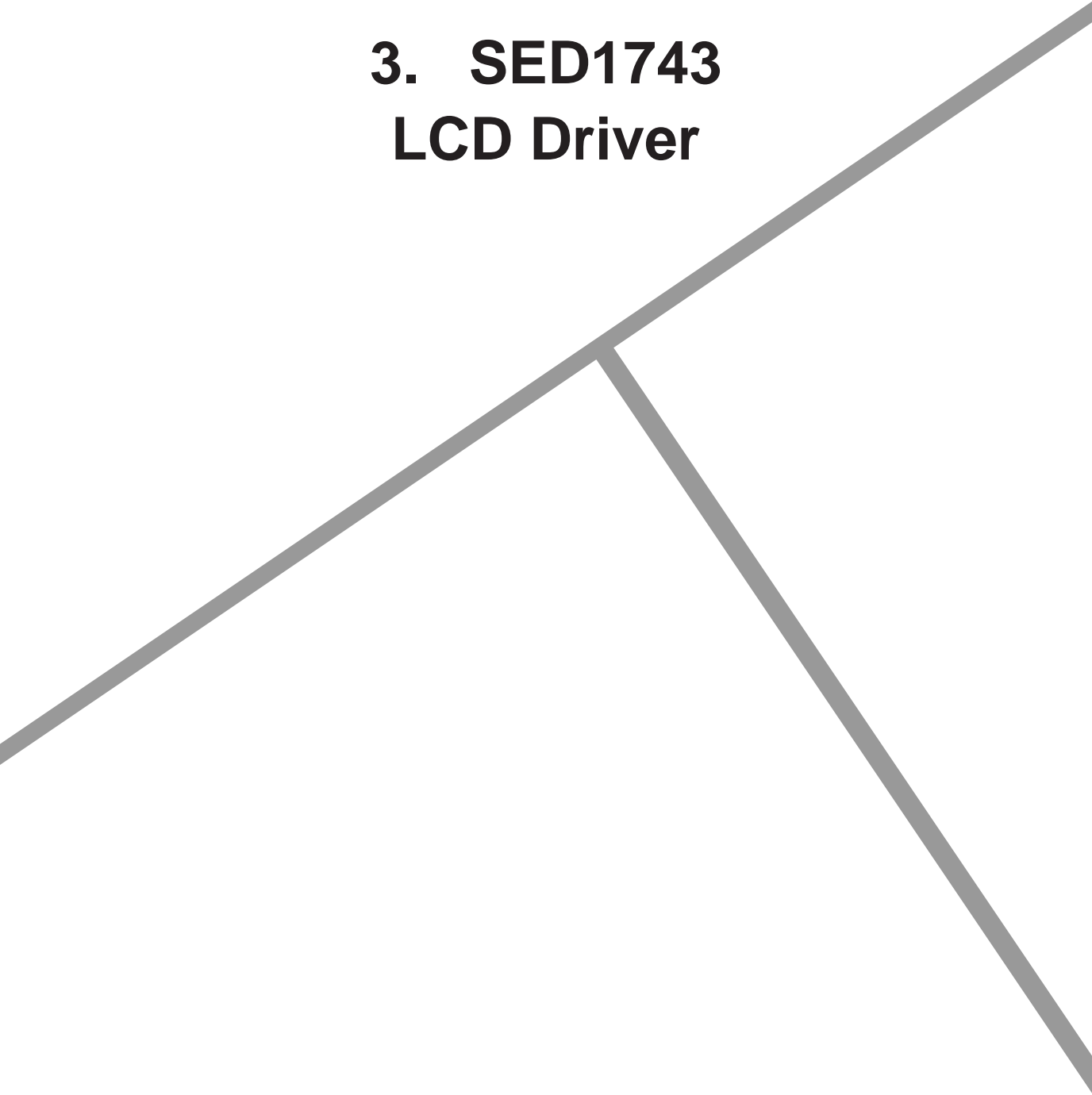

Contents

1. OVERVIEW	3-1
2. FEATURES	3-1
3. BLOCK DIAGRAM	3-1
4. PIN DESCRIPTON	3-2
5. SPECIFICATIONS	3-2
5-1 Absolute Maximum Ratings	3-2
5-2 Recommended Operating Conditions	3-3
5-3 DC Electrical Characteristics	3-3
Operating voltage range	3-4
5-4 AC Electrical Characteristics	3-4
Input timing	3-4
Input timing waveform	3-5
Output timing	3-5
Output timing waveform	3-6
6. TIMING DIAGRAMS	3-7
1/240 Duty Cycle	3-7
7. PACKAGE DIMENSIONS	3-8
7-1 Chip Package (SED1743D1B)	3-8
Pad coordinates	3-9
7-2 Tape-carrier Package	3-10
Tape-carrier pinout	3-10
Dimensional outline drawing	3-11
8. FUNCTIONAL DESCRIPTION	3-12
8-1 Shift Register	3-12
8-2 Level Shifter	3-12
8-3 LCD Drivers	3-12
8-4 Clk Monitor	3-12
9. APPLICATION NOTES	3-12
9-1 Voltage Levels	3-12
9-2 Power-up and Power-down Precautions	3-12
9-3 Clk Monitor Circuit	3-13
10. TYPICAL APPLICATION	3-14

SED1743 LCD Common Driver

1. OVERVIEW

The SED1743 is an LCD common driver for high-resolution dot-matrix panels, which incorporates 160 row driver outputs. It is designed for use in conjunction with the SED1742 and SED1744 column drivers.

The SED1743 features a wide range of LCD drive voltages. The upper and lower drive voltages, V_0 and V_5 , are independent of the chip supplies. This enables the LCD drive bias voltages to be supplied from an external source. As a result, the SED1743 is compatible with a large range of LCD panels.

The SED1743 uses a daisy-chain enable system which decreases power consumption and eliminates the need for separate enable signals for each driver.

The SED1743 operates from a 2.7 to 5.5 V supply and is available in both chip packages and tape-carrier packages (TCPs).

2. FEATURES

- 160 (80×2) LCD common drive outputs
- Pin-selectable output shift direction
- Adjustable LCD drive voltages
- Duty cycles up to 1/480
- Zero-bias display disable function
- Silicon-gate CMOS technology
- 1 k Ω typical output impedance
- 14 to 40 V LCD drive voltages
- 2.7 to 5.5 V supply
- Chip (SED1743D1B) or tape-carrier packages (SED1743T0A)

3. BLOCK DIAGRAM

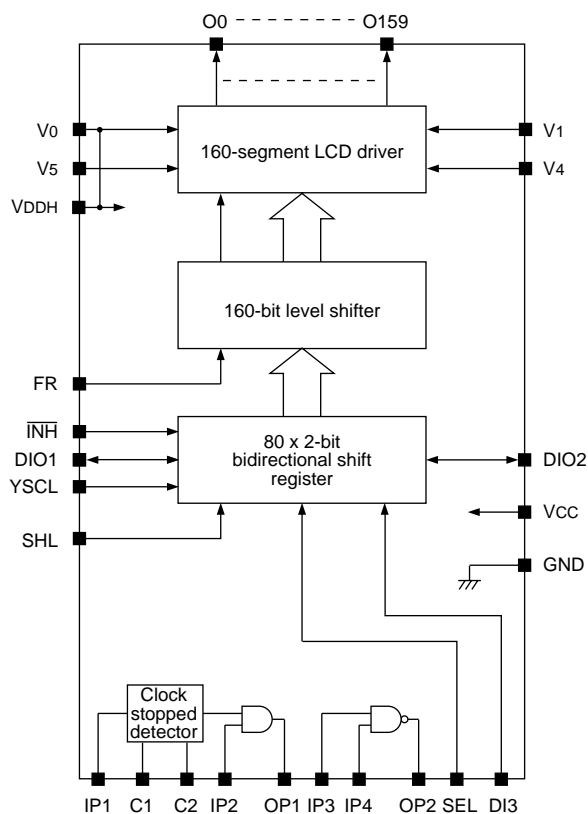

SED1743 LCD Common Driver

4. PIN DESCRIPTION

Number	Name	Description
39 to 183, 1 to 15	O0 to O159	LCD common drive outputs
16, 17	DIO2, DIO1	Serial data input/outputs
18	GND	Ground
19	SEL	Shift register mode select input
20	OP1	Clock monitor output
21	C1	First charge hold input. A capacitor should be connected between this pin and ground.
22	IP1	Halt detector clock input
23	C2	Second charge hold input. A resistor and capacitor should be connected between this pin and ground.
24	IP2	IP2 is connected to one input of an internal AND gate. The other input is connected to the halt detector output. Internal pulldown resistor
25	DI3	Scan pulse input when in 2×80 mode.
26	IP3	NAND gate input. Internal pulldown resistor
27	SHL	Shift direction select input
28	YSCL	Serial data shift clock. Negative-edge triggered.
29	IP4	NAND gate input
30	INH	Display blanking input
31	OP2	NAND gate output
32	Vcc	Logic supply
33	FR	Common drive signal polarity select input
34 to 38	V5, V4, V1, V0 and VDDH	Segment drive voltage inputs

5. SPECIFICATIONS

5-1 Absolute Maximum Ratings

Parameter	Symbol	Rating	Unit
Supply voltage range	Vcc	-0.3 to 7.0	V
	VDDH (V0)	-0.3 to 45.0	V
	V1, V4 and V5	VGND - 0.3 to VDDH + 0.3	V
Input voltage range	Vi	VGND - 0.3 to VCC + 0.3	V
Output voltage range	Vo	VGND - 0.3 to VCC + 0.3	V
DIO output current	Io	20	mA
Operating temperature range	Topg	-20 to 75	deg. C
Storage temperature range	Tstg	-65 to 150 (SED1743D1B)	deg. C
		-55 to 100 (SED1743T0A)	

Notes

- Care should be taken during the power-on and power-off sequence. See Application Notes.
- Display drive voltages should always be such that $VDDH (V0) \geq V1 \geq V4 \geq V5 \geq VGND$ as shown in the following figure.

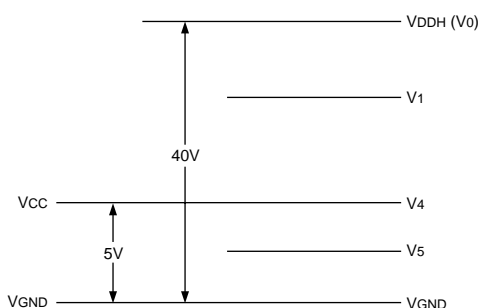

SED1743 LCD Common Driver

5-2 Recommended Operating Conditions

Ta = 25 deg. C

Parameter	Symbol	Rating	Unit
Logic supply voltage	V _{CC}	5	V
Segment driver supply voltage range	V _{DDH}	14 to 40	V

Ta = 25 deg. C

Parameter	Symbol	Rating	Unit
Logic supply voltage	V _{CC}	2.7	V
Segment driver supply voltage range	V _{DDH}	14 to 28	V

5-3 DC Electrical Characteristics

V_{CC} = 5 V ±10%, V₅ = 0 V, Ta = -20 to 75 deg. C

Parameter	Symbol	Condition	Rating			Unit	
			Min.	Typ.	Max.		
Quiescent current	I _{GND}	V _{DDH} = 14 to 40 V, V _{IH} = V _{CC} , V _{IL} = V _{GND}	—	—	25	μA	
Operating current	I _{CC}	V _{CC} = 5 V, V _{IH} = V _{CC} , V _{IL} = V _{GND} , f _{YSL} = 33.6 kHz, frame frequency = 70 Hz, no load	—	9	20	μA	
		V _{CC} = 2.7 V, other conditions as above	—	6	10	μA	
	I _{DDH}	V _{CC} = 5 V, V _{DDH} = V ₀ = 30 V, V ₁ = 28 V, V ₄ = 2 V, V ₅ = 0 V, other conditions as for I _{CC}	—	18	40	μA	
Segment driver input voltage	V ₁		8/9V _{DDH}	—	V _{DDH}	V	
	V ₄ , V ₅		V _{GND}	—	1/9V _{DDH}	V	
LOW-level input voltage	V _{IL}	V _{CC} = 2.7 to 5.5 V	—	—	0.2V _{CC}	V	
HIGH-level input voltage	V _{IH}		0.8V _{CC}	—	—	V	
LOW-level output voltage	V _{OL}	V _{CC} = 2.7 to 5.5 V	I _{OH} = 0.3 mA	—	—	0.4	V
HIGH-level output voltage	V _{OH}			I _{OH} = -0.3 mA	V _{CC} - 0.4	—	V
Segment ON resistance	R _{COM}	ΔV _{ON} = 0.5 V	V _{DDH} = 30 V	—	1.0	2.3	kΩ
			V _{DDH} = 20 V	—	1.2	2.8	
LOW-level input leakage current	I _{LI}	V _{GND} ≤ V _I ≤ V _{CC}	—	—	2	μA	
HIGH-level input leakage current	I _{HI}	V _I ≤ V _{CC}	40	80	180	μA	
Input/output leakage current	I _{LI/O}	V _{GND} ≤ V _{IN} ≤ V _{CC}	—	—	5	μA	
Input capacitance	C _I	f = 1 MHz, Ta = 25 deg. C, chip package	—	—	8	pF	
Input/output capacitance	C _{I/O}	f = 1 MHz, Ta = 25 deg. C, chip package	—	—	15	pF	

SED1743 LCD Common Driver

Operating voltage range

The maximum LCD supply voltage, VDDH, depends on VCC, as shown in the following figure.

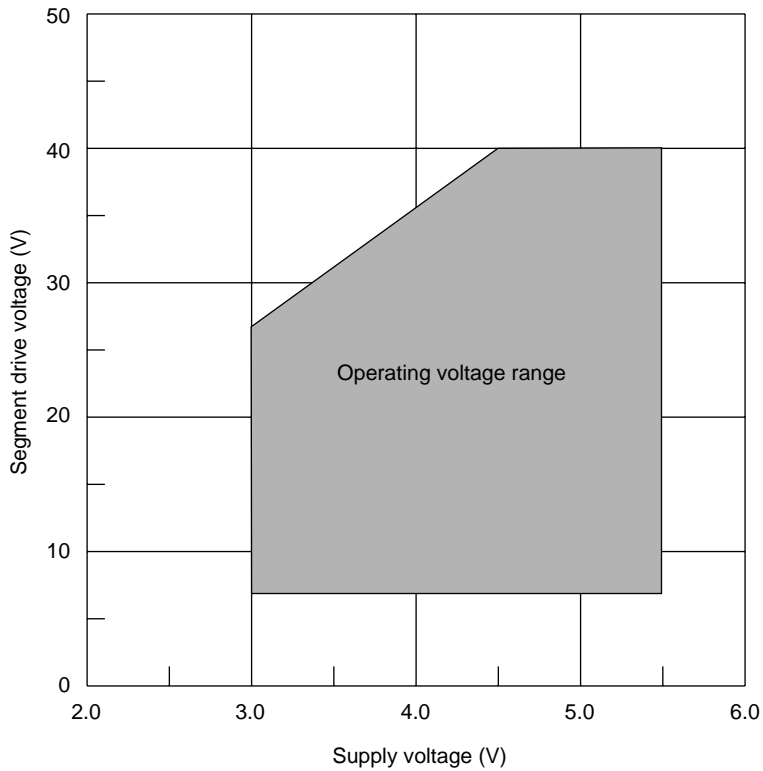

5-4 AC Electrical Characteristics

Input timing

VCC = 5 V ±10%, Ta = -20 to 75 deg. C

Parameter	Symbol	Condition	Rating		Unit
			Min.	Max.	
YSCL period	t _{CCL}		400	—	ns
YSCL HIGH-level pulsewidth	t _{WCLH}		70	—	ns
YSCL LOW-level pulsewidth	t _{WCHL}		330	—	ns
Data setup time	t _{bs}		100	—	ns

Parameter	Symbol	Condition	Rating		Unit
			Min.	Max.	
Data hold time	t _{DH}		40	—	ns
FR delay time	t _{DFR}		-300	300	ns
Input signal rise time	t _r		—	50	ns
Input signal fall time	t _f		—	50	ns

SED1743 LCD Common Driver

VCC = 2.7 to 4.5 V, Ta = -20 to 75 deg. C

Parameter	Symbol	Condition	Rating		Unit
			Min.	Max.	
YSCL period	t _{cCL}		800	—	ns
YSCL HIGH-level pulsewidth	t _{wCLH}		140	—	ns
YSCL LOW-level pulsewidth	t _{wCHL}		660	—	ns
Data setup time	t _{DS}		200	—	ns

Parameter	Symbol	Condition	Rating		Unit
			Min.	Max.	
Data hold time	t _{DH}		80	—	ns
FR delay time	t _{DFR}		-600	600	ns
Input signal rise time	t _r		—	100	ns
Input signal fall time	t _f		—	100	ns

Input timing waveform

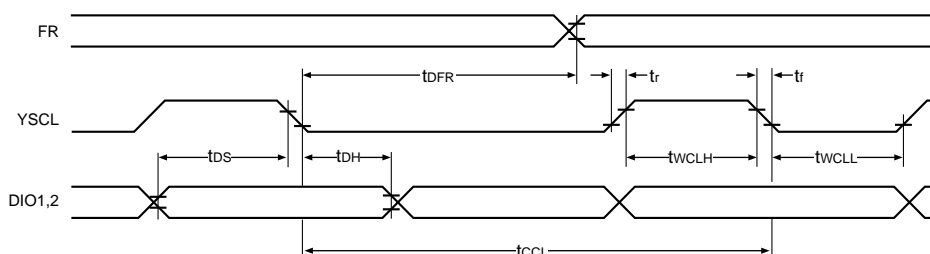

Output timing

VCC = 5 V ±10%, VDDH = 14 to 40 V

Parameter	Symbol	Condition	Rating		Unit
			Min.	Max.	
YSCL to DIO delay time	t _{pdDOCL}	CL = 15 pF	—	300	ns
YSCL to common output delay time	t _{pdCCL}	CL = 100 pF	—	700	ns
INH common output delay time	t _{pdCINH}		—	700	ns
FR to common output delay time	t _{pdCFR}		—	700	ns
IP1 to OP1 delay time	t _{d1}	CL = 15 pF	—	4C2R2	ns
IP1 to OP1 release time	t _{dT1}		—	2t _{YD}	ns
IP2 to OP1 delay time	t _{d2}		—	100	ns
IP2 to OP1 release time	t _{dT2}		—	100	ns

VCC = 3.0 to 4.5 V, Ta = -20 to 75 deg. C

Parameter	Symbol	Condition	Rating		Unit
			Min.	Max.	
YSCL to DIO delay time	t _{pdDOCL}	CL = 15 pF	—	600	ns
YSCL to common output delay time	t _{pdCCL}	CL = 100 pF	—	1400	ns
INH common output delay time	t _{pdCINH}		—	1400	ns
FR to common output delay time	t _{pdCFR}		—	1400	ns
IP1 to OP1 delay time	t _{d1}	CL = 15 pF	—	4C2R2	ns
IP1 to OP1 release time	t _{dT1}		—	2t _{YD}	ns
IP2 to OP1 delay time	t _{d2}		—	200	ns
IP2 to OP1 release time	t _{dT2}		—	200	ns

Note

YD is the scan start pulse. See the clock monitor circuit diagram for values of C2 and R2.

SED1743 LCD Common Driver

Output timing waveform

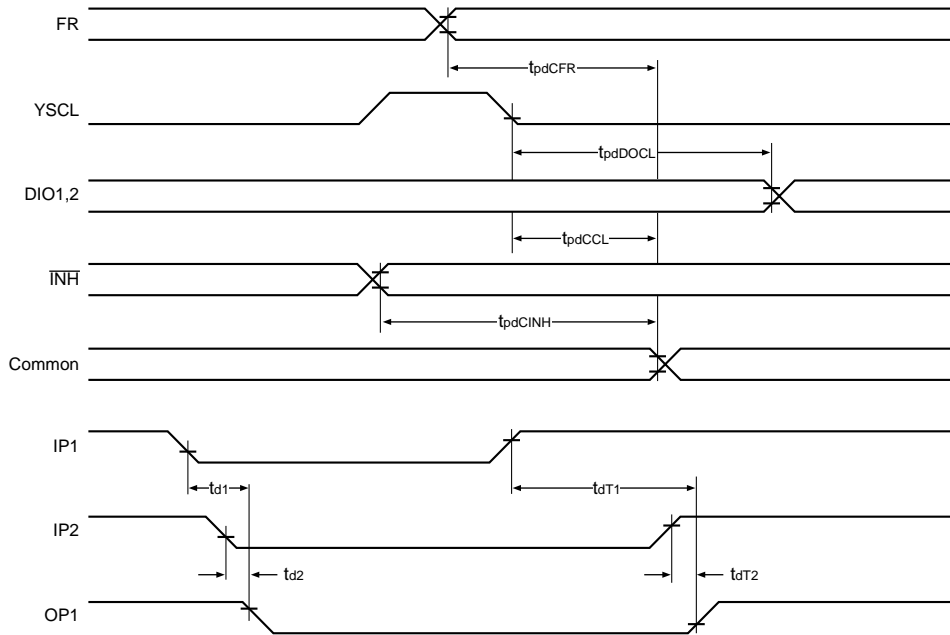

6. TIMING DIAGRAMS

1/240 Duty Cycle

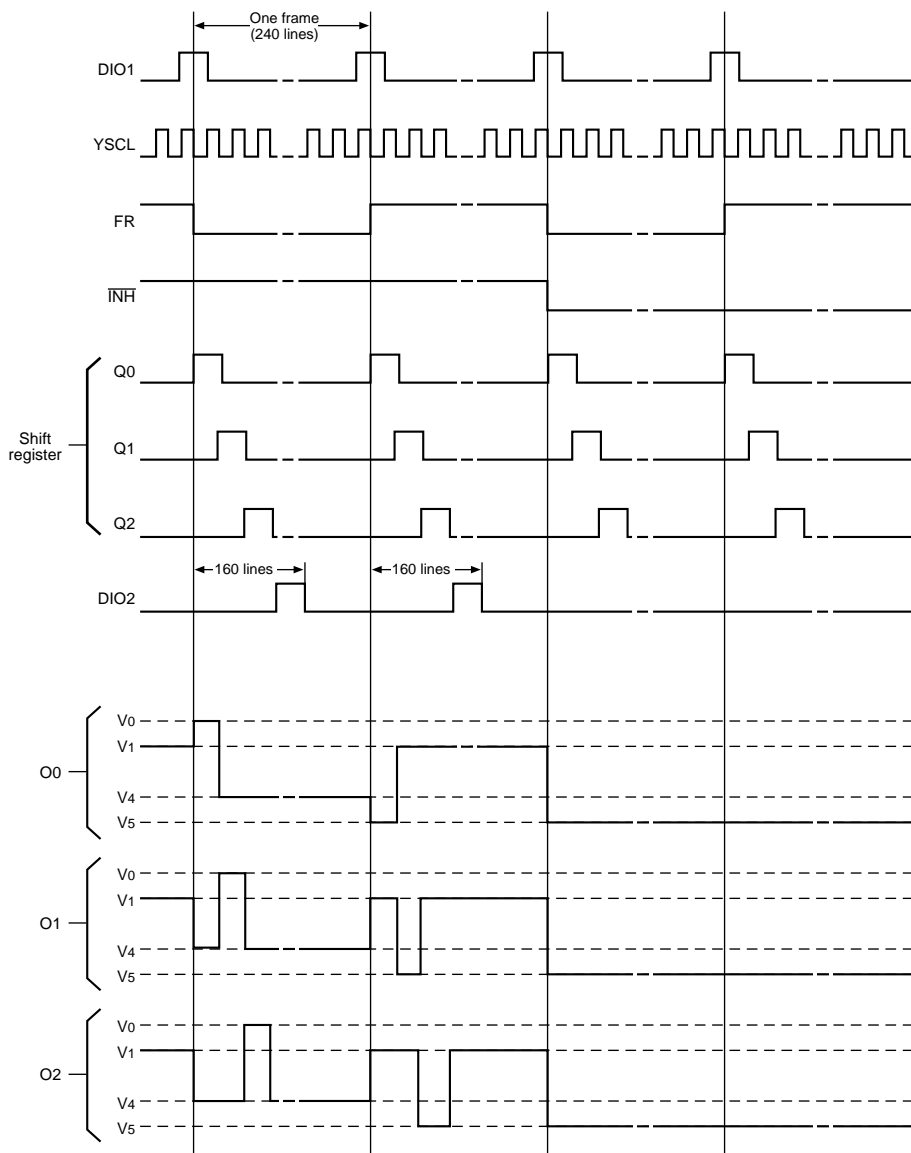

SED1743 LCD Common Driver

7. PACKAGE DIMENSIONS

7-1 Chip Package (SED1743D1B)

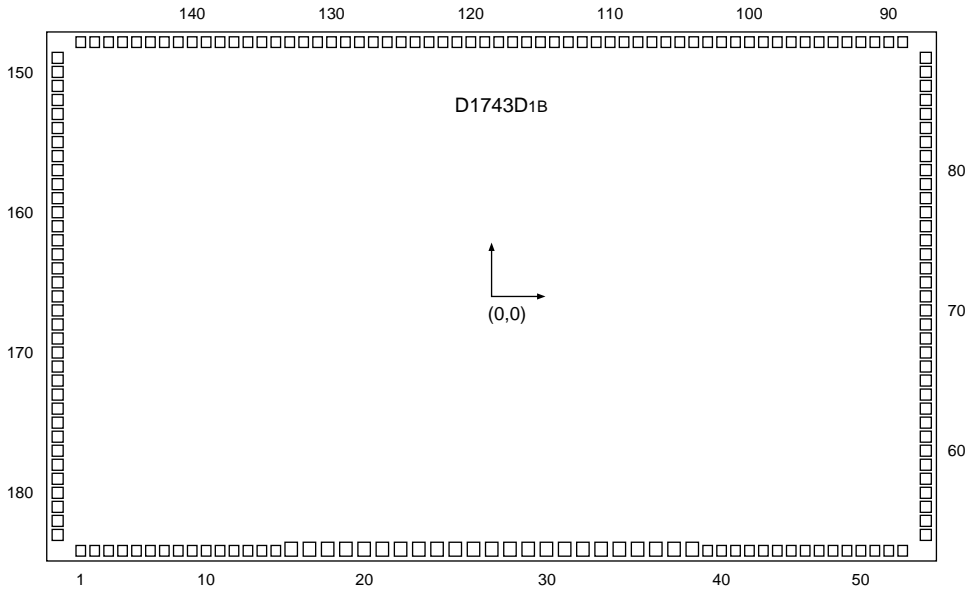

- Chip size: 7.30×4.48 mm
- Chip thickness: 525 ± 25 μ m
- Pad pitch: 108 μ m (Min.)
- Gold bump dimensions (SED1743D1B):
 - Size A: $94 \times 134 \pm 20$ μ m (pads 1 to 15, 39 to 183)
 - Size B: $115 \times 148 \pm 20$ μ m (pads 16 to 33 and 38)
 - Size C: $115 \times 134 \pm 20$ μ m (pads 34 to 37)

SED1743 LCD Common Driver

Pad coordinates

Unit: μm

PAD No.	PAD Name	X	Y	PAD No.	PAD Name	X	Y	PAD No.	PAD Name	X	Y
1	O145	-3228	-2064	62	O23	3474	-975	123	O84	-487	2064
2	O146	-3120		63	O24		-866	124	O85	-596	
3	O147	-3012		64	O25		-758	125	O86	-704	
4	O148	-2903		65	O26		-650	126	O87	-812	
5	O149	-2795		66	O27		-542	127	O88	-921	
6	O150	-2687		67	O28		-433	128	O89	-1029	
7	O151	-2578		68	O29		-325	129	O90	-1137	
8	O152	-2470		69	O30		-217	130	O91	-1245	
9	O153	-2362		70	O31		-108	131	O92	-1354	
10	O154	-2253		71	O32		0	132	O93	-1462	
11	O155	-2145		72	O33		108	133	O94	-1570	
12	O156	-2037		73	O34		217	134	O95	-1679	
13	O157	-1929		74	O35		325	135	O96	-1787	
14	O158	-1820		75	O36		433	136	O97	-1895	
15	O159	-1712		76	O37		542	137	O98	-2004	
16	DIO2	-1550	-2058	77	O38		650	138	O99	-2112	
17	DIO1	-1417		78	O39		758	139	O100	-2220	
18	GND	-1284		79	O40		866	140	O101	-2328	
19	SEL	-1151		80	O41		975	141	O102	-2437	
20	OP1	-1018		81	O42		1083	142	O103	-2545	
21	C1	-885		82	O43		1191	143	O104	-2653	
22	IP1	-752		83	O44		1300	144	O105	-2762	
23	C2	-619		84	O45		1408	145	O106	-2870	
24	IP2	-486		85	O46		1516	146	O107	-2978	
25	DI3	-353		86	O47		1625	147	O108	-3087	
26	IP3	-220		87	O48		1733	148	O109	-3195	
27	SHL	-87		88	O49		1841	149	O110	-3474	1841
28	YSCL	46		89	O50	3195	2064	150	O111		1733
29	IP4	179		90	O51	3087		151	O112		1625
30	INH	312		91	O52	2978		152	O113		1516
31	OP2	445		92	O53	2870		153	O114		1408
32	Vcc	578		93	O54	2762		154	O115		1300
33	FR	711		94	O55	2553		155	O116		1191
34	V5	872	-2026	95	O56	2545		156	O117		1083
35	V4	1034		96	O57	2437		157	O118		975
36	V1	1195		97	O58	2328		158	O119		866
37	V0	1357		98	O59	2220		159	O120		758
38	VDDH	1550	-2058	99	O60	2112		160	O121		650
39	O0	1712	-2064	100	O61	2004		161	O122		542
40	O1	1820		101	O62	1895		162	O123		433
41	O2	1929		102	O63	1787		163	O124		325
42	O3	2037		103	O64	1679		164	O125		217
43	O4	2145		104	O65	1570		165	O126		108
44	O5	2253		105	O66	1462		166	O127		0
45	O6	2362		106	O67	1354		167	O128		-108
46	O7	2470		107	O68	1245		168	O129		-217
47	O8	2578		108	O69	1137		169	O130		-325
48	O9	2687		109	O70	1029		170	O131		-433
49	O10	2795		110	O71	921		171	O132		-542
50	O11	2903		111	O72	812		172	O133		-650
51	O12	3012		112	O73	704		173	O134		-758
52	O13	3120		113	O74	596		174	O135		-866
53	O14	3228		114	O75	487		175	O136		-975
54	O15	3474	-1841	115	O76	379		176	O137		-1083
55	O16		-1733	116	O77	271		177	O138		-1191
56	O17		-1625	117	O78	162		178	O139		-1300
57	O18		-1516	118	O79	54		179	O140		-1408
58	O19		-1408	119	O80	-54		180	O141		-1516
59	O20		-1300	120	O81	-162		181	O142		-1625
60	O21		-1191	121	O82	-271		182	O143		-1733
61	O22		-1083	122	O83	-379		183	O144		-1841

SED1743 LCD Common Driver

7-2 Tape-carrier Package

Tape-carrier pinout

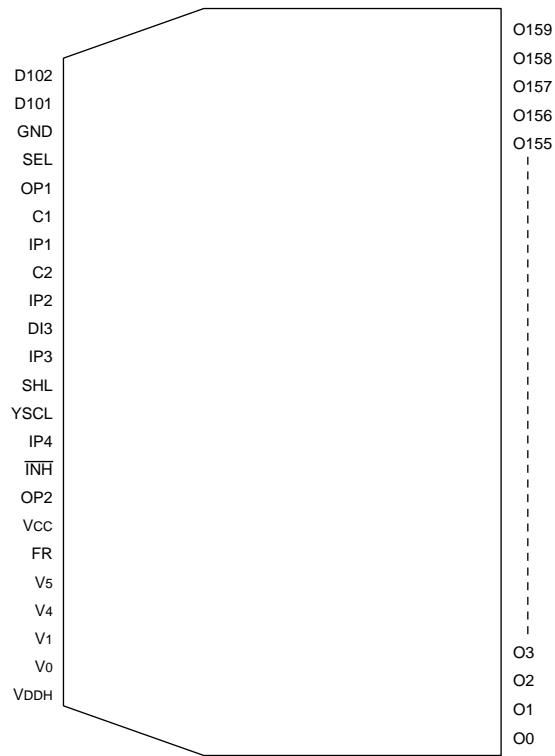

SED1743 LCD Common Driver

Dimensional Outline Drawing

SED1743T0A

For reference

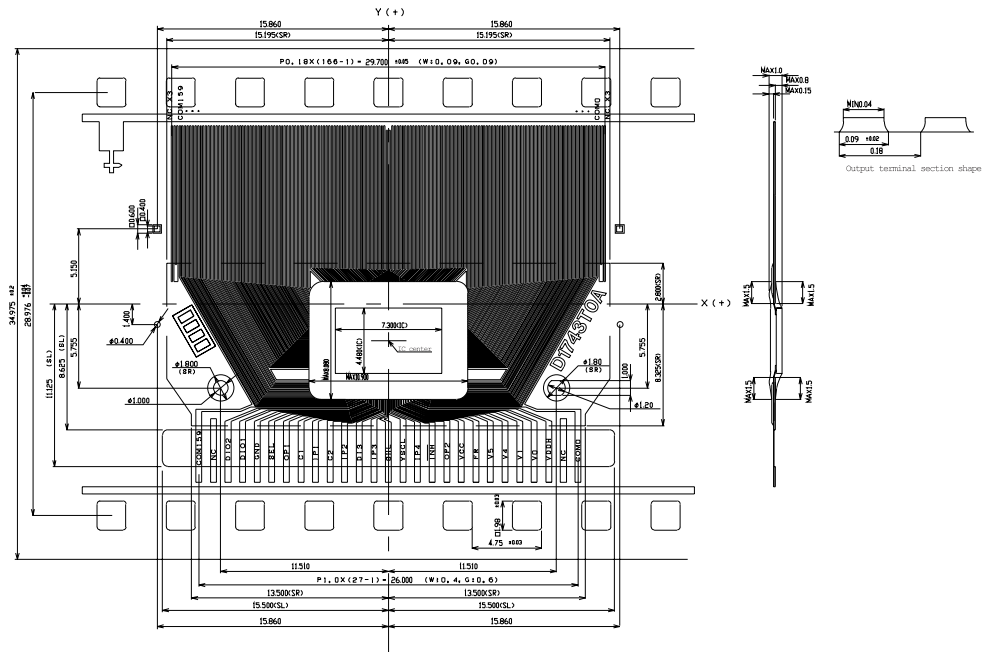

Unit: mm

8. FUNCTIONAL DESCRIPTION

8-1 Shift Register

The shift register is a bidirectional shift register, where the shift direction is selected by SHL. The effect of SHL on the shift direction and on the input data sequence is shown in table 1.

Table 1. Data sequence and shift direction

SHL	LCD outputs							Shift direction	
	O159	O158	O157	...	O2	O1	O0	DIO1	DIO2
L	a	b	c	...	x	y	z	Input	Output
H	z	y	x	...	c	b	a	Output	Input

SEL is used to select the operating mode of the shift register. When SEL is HIGH, 2 × 80 mode is selected. When SEL is LOW, 1 × 160 MODE mode is selected.

8-2 Level Shifter

The level shifter converts the logic-level signals from the latch into the LCD driver input voltage levels.

8-3 LCD Drivers

The LCD drivers generate the AC LCD drive waveforms. The output voltages are determined by the polarity of the FR signal, as shown in table 2.

Table 2. Driver output voltage

$\overline{\text{INH}}$	Input data	FR	Output voltage
H	H	H	V5
		L	V ₀ (V _{DDH})
	L	H	V ₁
		L	V ₄
L	×	×	V ₅

Note

× = don't care

8-4 Clock Monitor

The LCD panel can be damaged if a DC signal is applied to the segments. This situation can occur when the AC drive clock stops while power is applied to the display. The clock monitor circuit detects this condition and sends OP1 LOW. If OP1 is connected to $\overline{\text{INH}}$, the display is protected from damage. See Application Notes.

9. APPLICATION NOTES

9-1 Voltage Levels

The recommended method of generating the LCD drive voltages, V₀ to V₅, is with a voltage divider between V_{DDH} and V_{GND}, buffered with voltage followers.

The lower drive level, V₅, is not necessarily at V_{GND}, and separate pins are used for the voltage levels when op-amps are used. A maximum voltage differential between V₅ and V_{GND} of 2.5 V is recommended since the driver efficiency decreases as the differential increases. Connect V₅ to GND when not using op-amps.

The resistances of the voltage divider resistors should be as low as possible and within power supply constraints as shown in the Typical Application circuit.

Note that fluctuations in I_{DDH} can cause dips in the V_{DDH} supply. The device will be damaged if the voltage dips below the point where the relationship V_{DDH} (V₀) ≥ V₁ ≥ V₄ ≥ V₅ ≥ V_{GND} breaks down. A stabilized power supply may be required when using the resistor network.

9-2 Power-up and Power-down Precautions

As the driver circuitry operates at high voltage, care should be taken when applying and removing power to the SED1743 to prevent damage. If the driver supply is applied when the logic supply is either not connected or below 2.9 V, excess current will flow into the SED1743 and damage the device. Normal operation is guaranteed if the correct power-up and power-down sequences are followed.

Power-up sequence: Power should be applied to VCC before, or at the same time as, power is applied to the driver circuitry.

Power-down sequence: Power should be removed from VCC after, or at the same time as, power is removed from the driver circuitry.

The SED1743 can also be damaged if the LCD output drivers start operating before the driver supplies stabilize. $\overline{\text{INH}}$ should be held LOW to hold the driver outputs at V₅ until the driver supplies have stabilized.

As an additional protective measure, insert a fast-blow fuse in series with the driver supply.

SED1743 LCD Common Driver

9-3 Clock Monitor Circuit

The clock monitor circuit sets OP1 LOW whenever the clock signals from the controller stops. Connecting OP1 to $\overline{\text{INH}}$ ensures that DC does not flow into the LCD panel.

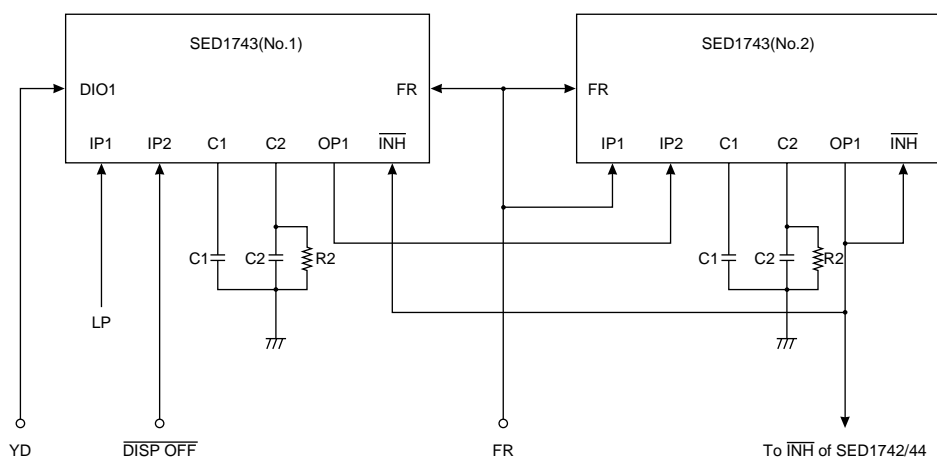

R2 is typically several $\text{M}\Omega$ and C1 and C2 are determined while monitoring OP1. C1 should be much larger than C2. Typical values under various signal conditions are shown in table 3.

Table 3. Driver output voltage

Input signal	C1	C2	R2
LP	0.47 μF	0.047 μF	3.3 $\text{M}\Omega$
FR	0.47 μF	0.047 μF	3.3 $\text{M}\Omega$

Notes

YD: $t_c = 17.8 \text{ ms}$, duty = 0.14 %

LP: $t_c = 40.4 \text{ ms}$, duty = 0.35 %

FR: $t_c = 3.53 \text{ ms}$, duty = 50 %

When the clock monitor feature is not required, tie IP1, IP2, IP3 and C2 LOW, and leave OP1, OP2 and C1 OPEN.

SED1743 LCD Common Driver

10. TYPICAL APPLICATION

