

# EPSON

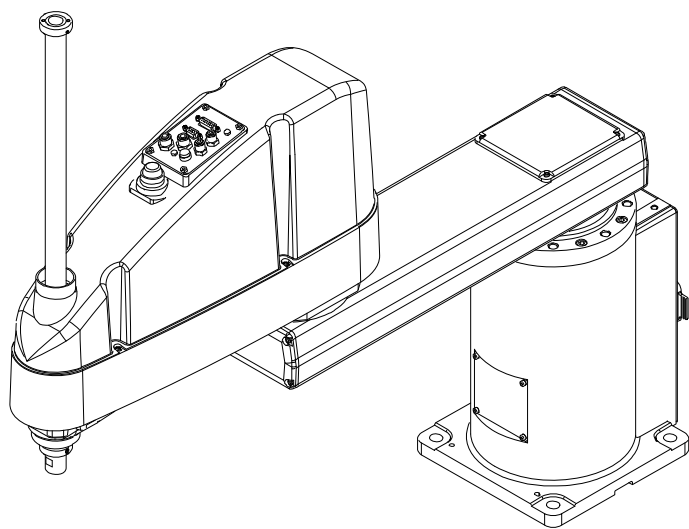

SCARA ROBOT

## *GX20 Series*

*Service Manual*

Rev.2

ENSM22YR0010

## CAUTION

- ❑ No part of this service manual may be reproduced or reprinted in any form without permission.
- ❑ Please note that even after the establishment of this service manual, changes may be made in the mechanism or parts of the product with the purpose of improving the quality and functions. Therefore, the contents described here may not match the actual product.
- ❑ The company names and product names described in this service manual are the trademarks or registered trademarks of the respective company.

EPSON is the registered trademark of Seiko Epson Corporation.  
Other product names are trademarks or registered trademarks of the respective company.

© **Seiko Epson Corporation. 2024**

## **Revision History**

If, even after the establishment and issue of the first edition of this manual, changes are made in the mechanism or parts of the product with the purpose of improving the performance and reliability, revised editions shall be issued as necessary.

# Table of Contents

## Chapter 1 Maintenance Information

<a href="#">1.1 Safety Maintenance</a>	<a href="#">7</a>
<a href="#">1.2 General Maintenance</a>	<a href="#">9</a>
<a href="#">1.2.1 Schedule for Maintenance Inspection</a>	<a href="#">9</a>
<a href="#">1.2.2 Inspection Point</a>	<a href="#">10</a>
<a href="#">1.2.3 Overhaul (Parts Replacement)</a>	<a href="#">11</a>
<a href="#">1.2.4 Tools</a>	<a href="#">15</a>
<a href="#">1.2.5 Greasing</a>	<a href="#">17</a>
<a href="#">1.2.6 Tightening Bolts/Screws</a>	<a href="#">19</a>
<a href="#">1.2.7 Matching Origins</a>	<a href="#">21</a>
<a href="#">1.3 Parts Layout</a>	<a href="#">22</a>
<a href="#">1.3.1 Table Top Mounting</a>	<a href="#">22</a>
<a href="#">1.3.2 Wall Mounting</a>	<a href="#">24</a>
<a href="#">1.3.3 Ceiling Mounting</a>	<a href="#">26</a>
<a href="#">1.4 Differences from the Table Top Mounting</a>	<a href="#">28</a>
<a href="#">1.4.1 Base Bottom Cover/Bottom Connector Unit</a>	<a href="#">28</a>
<a href="#">1.4.2 Connector Plate/Wall Mounting Plate</a>	<a href="#">29</a>
<a href="#">1.4.3 Base Unit</a>	<a href="#">30</a>
<a href="#">1.4.4 Arm 1 Unit</a>	<a href="#">31</a>

## Chapter 2 Maintenance

<a href="#">2.1 Overview</a>	<a href="#">33</a>
<a href="#">2.1.1 Precautions for Maintenance</a>	<a href="#">33</a>
<a href="#">2.1.2 Viewing the Maintenance Page</a>	<a href="#">34</a>
<a href="#">2.2 Joint #1</a>	<a href="#">35</a>
<a href="#">2.2.1 Removing the J1 Motor Unit</a>	<a href="#">35</a>
<a href="#">2.2.2 Removing the J1 Motor Unit</a>	<a href="#">40</a>

<a href="#">2.2.3 Disassembling the J1 Motor Unit</a>	<a href="#">43</a>
<a href="#">2.2.4 Assembling the J1 Motor Unit</a>	<a href="#">44</a>
<a href="#">2.2.5 Removing the J1 Reduction Gear Unit</a>	<a href="#">47</a>
<a href="#">2.2.6 Installing the J1 Reduction Gear Unit</a>	<a href="#">49</a>
<a href="#">2.3 Joint #2</a>	<a href="#">54</a>
<a href="#">2.3.1 Removing the J2 Motor Unit</a>	<a href="#">54</a>
<a href="#">2.3.2 Installing the J2 Motor Unit</a>	<a href="#">56</a>
<a href="#">2.3.3 Disassembling the J2 Motor Unit</a>	<a href="#">61</a>
<a href="#">2.3.4 Assembling the J2 Motor Unit</a>	<a href="#">62</a>
<a href="#">2.3.5 Removing the J2 Reduction Gear Unit</a>	<a href="#">65</a>
<a href="#">2.3.6 Installing the J2 Reduction Gear Unit</a>	<a href="#">67</a>
<a href="#">2.4 Joint #3</a>	<a href="#">71</a>
<a href="#">2.4.1 Removing the J3 Motor Unit</a>	<a href="#">71</a>
<a href="#">2.4.2 Installing the J3 Motor Unit</a>	<a href="#">75</a>
<a href="#">2.4.3 Replacing the J3 Motor Unit</a>	<a href="#">80</a>
<a href="#">2.4.4 Removing the J3 Timing Belt (Z)</a>	<a href="#">81</a>
<a href="#">2.4.5 Installing the J3 Timing Belt (Z)</a>	<a href="#">82</a>
<a href="#">2.4.6 Removing the J3 Brake</a>	<a href="#">84</a>
<a href="#">2.4.7 Installing the J3 Brake</a>	<a href="#">86</a>
<a href="#">2.5 Joint #4</a>	<a href="#">88</a>
<a href="#">2.5.1 Removing the J4 Motor Unit</a>	<a href="#">88</a>
<a href="#">2.5.2 Installing the J4 Motor Unit</a>	<a href="#">91</a>
<a href="#">2.5.3 Replacing the J4 Motor Unit/Brake</a>	<a href="#">96</a>
<a href="#">2.5.4 Removing the Timing Belt (U)</a>	<a href="#">99</a>
<a href="#">2.5.5 Installing the Timing Belt (U)</a>	<a href="#">102</a>
<a href="#">2.5.6 Removing the J4 Reduction Gear</a>	<a href="#">107</a>
<a href="#">2.5.7 Installing the J4 Reduction Gear</a>	<a href="#">111</a>
<a href="#">2.6 Bellows</a>	<a href="#">118</a>
<a href="#">2.6.1 Removing the Bellows</a>	<a href="#">119</a>
<a href="#">2.6.2 Installing the Bellows</a>	<a href="#">120</a>



<a href="#">2.7 Ball Screw Spline Unit</a>	<a href="#">123</a>
<a href="#">2.7.1 Removing the Ball Screw Spline Unit</a>	<a href="#">123</a>
<a href="#">2.7.2 Installing the Ball Screw Spline Unit</a>	<a href="#">125</a>
<a href="#">2.7.3 Greasing the Ball Screw Spline Unit</a>	<a href="#">128</a>
<a href="#">2.8 Board, LED Indicator</a>	<a href="#">132</a>
<a href="#">2.8.1 Replacing the DC/DC Board</a>	<a href="#">132</a>
<a href="#">2.8.2 Replacing the Control Board</a>	<a href="#">133</a>
<a href="#">2.8.3 Replacing the LED Indicator</a>	<a href="#">134</a>
<a href="#">2.9 Cable Unit</a>	<a href="#">135</a>
<a href="#">2.9.1 Removing the Cable Unit</a>	<a href="#">135</a>
<a href="#">2.9.2 Installing the Cable Unit</a>	<a href="#">145</a>
<a href="#">2.10 Installing/Removing the Cover</a>	<a href="#">158</a>
<a href="#">2.10.1 Arm Upper Cover</a>	<a href="#">159</a>
<a href="#">2.10.2 Arm Lower Cover</a>	<a href="#">160</a>
<a href="#">2.10.3 Base Bottom Cover</a>	<a href="#">161</a>
<a href="#">2.10.4 User Plate</a>	<a href="#">162</a>
<a href="#">2.10.5 Connector Plate (Table Top Mounting Type)</a>	<a href="#">166</a>
<a href="#">2.10.6 Connector Plate (Wall Mounting Type)</a>	<a href="#">168</a>

## **Chapter 3 Adjustment**

---

<a href="#">3.1 Calibration</a>	<a href="#">170</a>
<a href="#">3.1.1 What is Calibration?</a>	<a href="#">170</a>
<a href="#">3.1.2 Calibration Methods</a>	<a href="#">171</a>
<a href="#">3.1.3 Workflow</a>	<a href="#">172</a>
<a href="#">3.1.4 Preparation</a>	<a href="#">174</a>
<a href="#">3.1.5 0-Pulse Position of Each Joint</a>	<a href="#">175</a>
<a href="#">3.1.6 Implementing Calibration</a>	<a href="#">177</a>
<a href="#">3.1.6.1 Implementing Calibration using the Wizard</a>	<a href="#">178</a>
<a href="#">3.1.6.2 Accurate Calibration of Joint #2</a>	<a href="#">188</a>
<a href="#">3.1.6.3 Calibration Using Right / Left Arm Orientations</a>	<a href="#">190</a>
<a href="#">3.1.6.4 Calibration Procedure without Using             Calibration Wizard</a>	<a href="#">192</a>

<a href="#">3.1.7 Verification</a>	<a href="#">198</a>
<a href="#">3.2 Adjusting the Timing Belt Tension</a>	<a href="#">199</a>
<a href="#">3.2.1 Belt Tension Values</a>	<a href="#">199</a>
<a href="#">3.2.2 Adjustment Method</a>	<a href="#">200</a>

## **Chapter 4 Block Diagram/Wiring Diagram**

---

<a href="#">4.1 Block Diagram</a>	<a href="#">204</a>
<a href="#">4.2 Wiring Diagram</a>	<a href="#">205</a>
<a href="#">4.2.1 Ground Wire</a>	<a href="#">205</a>
<a href="#">4.2.2 Motor Cable</a>	<a href="#">206</a>
<a href="#">4.2.3 Encoder</a>	<a href="#">207</a>
<a href="#">4.2.4 Brake Wire, LED Wire</a>	<a href="#">208</a>
<a href="#">4.2.5 User Plate</a>	<a href="#">209</a>

## **Chapter 5 Exploded View/Maintenance Parts List**

---

<a href="#">5.1 Exploded View</a>	<a href="#">211</a>
<a href="#">5.2 Maintenance Parts List</a>	<a href="#">213</a>

CHAPTER

1

# Maintenance Information

## 1.1 Safety Maintenance

Maintenance of robot system shall always be performed by personnel who has taken safety training.

Personnel who has taken safety training refers to a person who has taken safety training for workers engaged in activities related to industrial robots as stipulated by the laws and regulations of each country (such as the knowledge on industrial robots, knowledge on operations and teaching, knowledge on activities concerning inspection, etc., and training on related laws). Personnel who has taken training held by the manufacturer refers to a person who has completed the introduction training and maintenance training.



WARNING

- Do not remove any parts that are not covered in this manual. Follow the maintenance procedure strictly as described in this manual. Do not proceed using any methods other than described in this manual when you do replace a part or maintain the equipment. Improper removal of parts or improper maintenance may not only cause improper function of the robot system but also serious safety problems.
- Keep away from the Manipulator while the power is ON if you have not taken the training courses. Do not enter the operating area while the power is ON. Entering the operating area with the power ON is extremely hazardous and may cause serious safety problems as the Manipulator may move even when it seems to be stopped.
- When you check the operation of the Manipulator after replacing parts, be sure to check it while you are outside of the safeguarded area. Checking the operation of the Manipulator while you are inside of the safeguarded area may cause serious safety problems as the Manipulator may move unexpectedly.
- Before operating the robot system, make sure that both the Emergency Stop switches and safeguard switch function properly. Operating the robot system when the switches do not function properly is extremely hazardous and may result in serious bodily injury and/or serious damage to the robot system as the switches cannot fulfill their intended functions in an emergency.
- To shut off power to the robot system, disconnect the power plug from the power source. Be sure to connect the AC power cable to a power receptacle. DO NOT connect it directly to a factory power source.
- Before performing any replacement procedure, turn OFF the Controller and related equipment, and then disconnect the power plug from the power source. Performing any replacement procedure with the power ON is extremely hazardous and may result in electric shock and/or malfunction of the robot system.
- When maintaining the manipulator, wear at least the following protective gear. Working without protective gear may cause serious safety problems.
  - Work clothes suitable for work
  - Helmet
  - Safety shoes



WARNING

- Do not allow foreign objects to enter the inside of the manipulator or the connection terminals. Energizing the manipulator with foreign objects in it may cause electric shock or malfunction, which is extremely dangerous.



CAUTION

- Be sure to connect the cables properly. Do not allow unnecessary strain on the cables. (Do not put heavy objects on the cables. Do not bend or pull the cables forcibly.) The unnecessary strain on the cables may result in damage to the cables, disconnection, and/or contact failure. Damaged cables, disconnection, or contact failure is extremely hazardous and may result in electric shock and/or improper function of the robot system.
- When operating maintenance of Manipulator, secure about 50 cm of empty space around the Manipulator.
- Carefully use alcohol, liquid gasket, and adhesive following respective instructions and instructions below. Careless use of alcohol, liquid gasket, or adhesive may cause a fire and/or safety problem.
  - Never put alcohol, liquid gasket, or adhesive close to fire.
  - Use alcohol, liquid gasket, or adhesive while ventilating the room.
  - Wear protective gear including a mask, protective goggles, and oil-resistant gloves.
  - If alcohol, liquid gasket, or adhesive gets on your skin, wash the area thoroughly with soap and water.
  - If alcohol, liquid gasket, or adhesive gets into your eyes or mouth, flush your eyes or wash out your mouth with clean water thoroughly, and then see a doctor immediately.
- Wear protective gear including a mask, protective goggles, and oil-resistant gloves during grease up. If grease gets into your eyes, mouth, or on your skin, follow the instructions below.
  - If grease gets into your eyes  
Flush them thoroughly with clean water, and then see a doctor immediately.
  - If grease gets into your mouth  
If swallowed, do not induce vomiting. See a doctor immediately.  
If grease just gets into your mouth, wash out your mouth with water thoroughly.
  - If grease gets on your skin  
Wash the area thoroughly with soap and water.

## 1.2 General Maintenance

Performing maintenance inspections properly is essential for preventing trouble and maintaining safety. This chapter describes the schedules for maintenance inspection and procedures.

Be sure to perform the maintenance inspections in accordance with the schedule.

### 1.2.1 Schedule for Maintenance Inspection

Inspection points are divided into five stages: daily, monthly, quarterly, biannual, and annual. The inspection points are added every stage. If the Manipulator is operated for 250 hours or longer per month, the inspection points must be added every 250 hours, 750 hours, 1,500 hours, and 3,000 hours operation.

	Inspection Point					
	Daily inspection	Monthly inspection	Quarterly inspection	Biannual inspection	Annual inspection	Overhaul (replacement)
1 month (250 h)	Inspect every day	√	-	-	-	-
2 months (500 h)		√	-	-	-	-
3 months (750 h)		√	√	-	-	-
4 months (1,000 h)		√	-	-	-	-
5 months (1,250 h)		√	-	-	-	-
6 months (1,500 h)		√	√	√	-	-
7 months (1,750 h)		√	-	-	-	-
8 months (2,000 h)		√	-	-	-	-
9 months (2,250 h)		√	√	-	-	-
10 months (2,500 h)		√	-	-	-	-
11 months (2,750 h)		√	-	-	-	-
12 months (3,000 h)		√	√	√	√	-
13 months (3,250 h)		√	-	-	-	-
⋮	⋮	⋮	⋮	⋮	⋮	⋮
20,000 h	-	-	-	-	-	√

## 1.2.2 Inspection Point

### Inspection Item

Inspection Point	Inspection Place	Daily	Monthly	Quarterly	Biannual	Annual
Check looseness or backlash of bolts/screws.	End effector mounting bolts	√	√	√	√	√
	Manipulator mounting bolts	√	√	√	√	√
Check looseness of connectors.	External connectors on Manipulator (on the Connector Plates etc.)	√	√	√	√	√
Visually check for external defects. Clean up if necessary.	External appearance of Manipulator	√	√	√	√	√
	External cables	-	√	√	√	√
Check for bends or improper location. Repair or place it properly if necessary.	Safeguard, etc.	√	√	√	√	√
Check the Brake operation	Joint #3, #4	√	√	√	√	√
Check whether unusual sound or vibration occurs.	Whole	√	√	√	√	√

### Inspection Method

Inspection Point	Inspection Method
Check looseness or backlash of bolts/screws.	Use a hexagonal wrench to check that the end effector mounting bolts and the Manipulator mounting bolts are not loose. When the bolts are loose, refer to <a href="#">1.2.6 Tightening Bolts/Screws</a> and tighten them to the proper torque.
Check looseness of connectors.	Check that connectors are not loose. When the connectors are loose, reattach it not to come off.
Visually check for external defects. Clean up if necessary.	Check the appearance of the Manipulator and clean up if necessary. Check the appearance of the cable, and if it is scratched, check that there is no cable disconnection.
Check for bends or improper location. Repair or place it properly if necessary.	Check that the safeguard, etc. are located properly. If the location is improper, place it properly.
Check the Brake operation	Check that the shaft does not fall when in MOTOR OFF. If the shaft falls when in MOTOR OFF and the Brake is not released, replace the Brake. Also, if the Brake is not released even when Brake release operation is performed, replace the Brake.
Check whether unusual sound or vibration occurs.	Check that there is no unusual sound or vibration during operation, no stiffness or looseness in the sliding parts or moving parts, and that the operation is performed smoothly. If an abnormality is suspected, replace the part in which the abnormality has occurred.

### 1.2.3 Overhaul (Parts Replacement)



CAUTION

- Overhaul timing is based on an assumption that all joints are operated for equal distance. If a particular joint has a high duty or high load, it is recommended to overhaul all joints (as many as possible) before exceeding 20,000 operation hours with the joint as a basis.

The parts for the Manipulator joints may cause accuracy decline or malfunction due to deterioration of the Manipulator resulting from long term use. In order to use the Manipulator for a long term, it is recommended to overhaul the parts (parts replacement).

The time between overhauls is 20,000 operation hours of the Manipulator as a rough indication.

However, it may vary depending on usage condition and degree of the load (such as when operated with the maximum motion speed and maximum acceleration / deceleration in continuous operation) applied on the Manipulator.

**NOTE** For the EPSON RC+ 7.0 Ver. 7.2.x or later (firmware Ver.7.2.x.x or later), the recommended replacement time for the parts subject to maintenance (Motors, Reduction Gears, Timing Belts, and Ball Screw Spline Unit) can be checked in the [Maintenance] dialog box of the EPSON RC+ 7.0.

**NOTE** The recommended replacement time for the maintenance parts is when it reaches the L10 life (time until 10% failure probability). In the [Maintenance] dialog box, the L10 life is displayed as 100%.

For the parts subject to overhaul, refer to [Chapter 5 Exploded View/Maintenance Parts List](#).

For details of replacement of each part, refer to [Chapter 2 Maintenance](#).

Please contact the supplier of your region for further information.

### How to View the Maintenance Information

The configured maintenance information can be checked in the EPSON RC+ 7.0 Ver.7.2.x or later.

- (1) Select the EPSON RC+ 7.0 menu-[Tools]-[Maintenance] to display the [Controller Tools] dialog box.

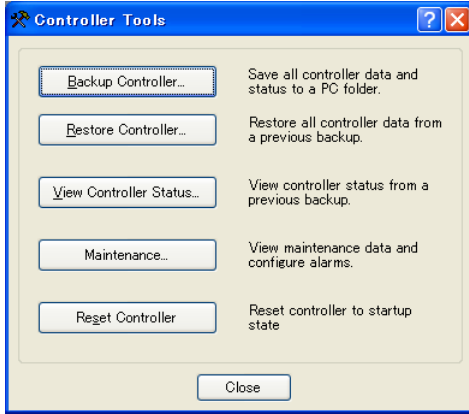

- (2) To check the Controller maintenance information, click the <Maintenance> button and display the [Maintenance] dialog box.

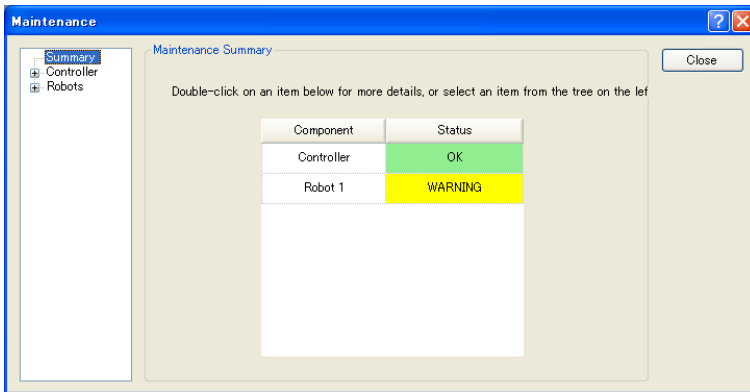

- (3) Select "General" or specify the axis from the tree to display information of the target parts.

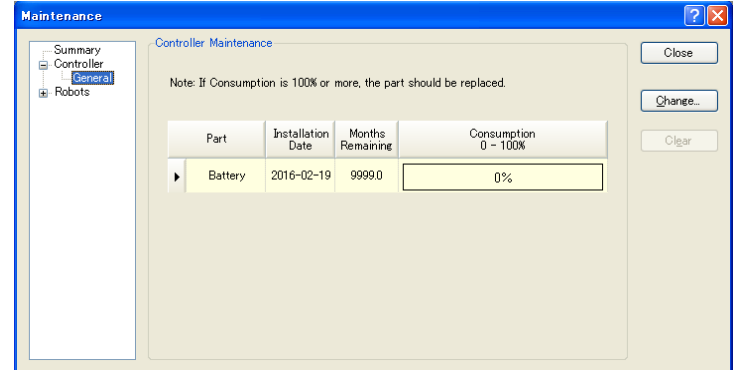

**NOTE** Remaining months is calculated based on the past operation conditions.



### How to Edit the Maintenance Information

The configured maintenance information can be edited in the EPSON RC+ 7.0 Ver.7.2.x or later.

When replaced the parts subject to maintenance (Motors, Reduction Gears, Timing Belts, and Ball screw spline) or greased to Joint #3 Ball Screw Spline Unit, please edit the Maintenance Information.

- (1) Select the EPSON RC+ 7.0 menu-[Tools]-[Maintenance] to display the [Controller Tools] dialog box.

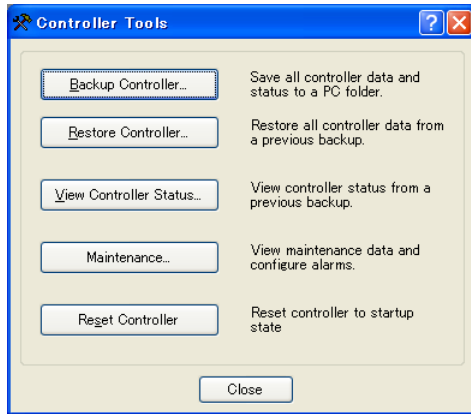

- (2) To edit the maintenance information, display the [Maintenance] dialog box.

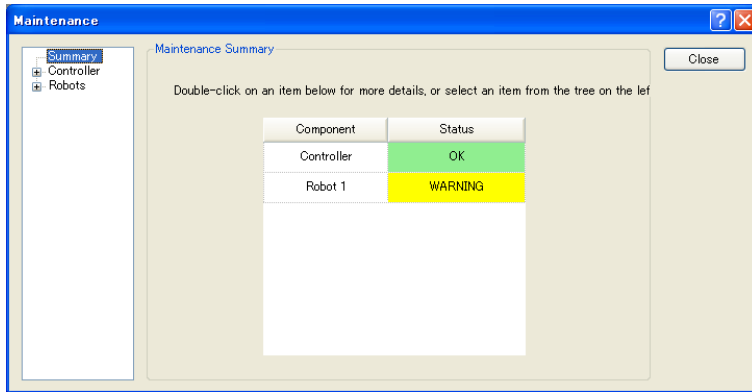

- (3) Select "General" or specify the axis from the tree to display information of the target parts.

- (4) Select the alarm to be changed and click the <Change> button.

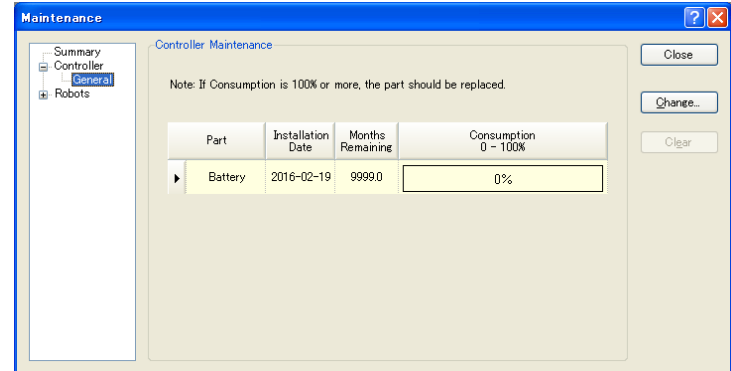

- (5) Display the [Change Alarm] dialog box and enter any of the followings.

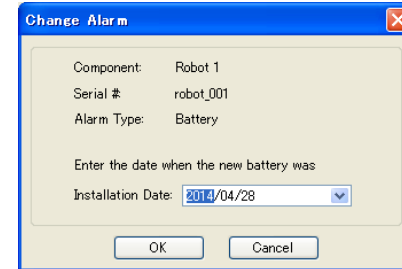

- (6) Click the <OK> button and change the specified alarm information.

## How to check the Manipulator operation hours

The Manipulator operation hours can be checked in [Controller Status Viewer] dialog - [Motor On Hours].

- (1) Select EPSON RC+ menu- [Tools] - [Controller] to open the [Controller Tools] dialog.
- (2) Click the <View Controller Status> button to open the [Browse For Folder] dialog.
- (3) Select the folder where the information is stored.
- (4) Click <OK> to view the [Controller Status Viewer] dialog.
- (5) Select [Robots] from the tree menu on the left side (Dialog image: EPSON RC+ 7.0)

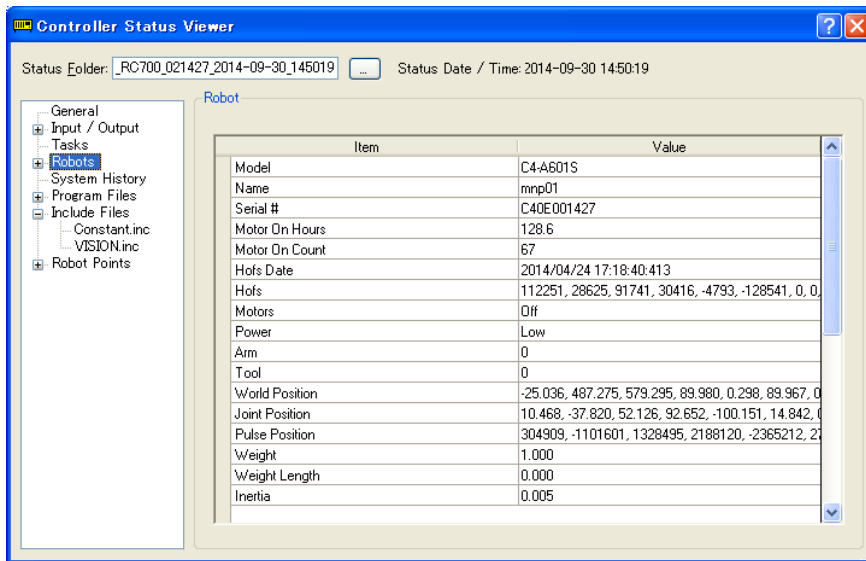

## 1.2.4 Tools

### Tools used

Name		Quantity	Note
Hexagonal wrench	width across flats: 1.5 mm	1	For M3 set screw
	width across flats: 2 mm	1	For M2.5 bolts and M4 set screw
	width across flats: 2.5 mm	1	For M3 bolts and M5 set screw
	width across flats: 3 mm	1	For M4 bolts
	width across flats: 4 mm	1	For M5 bolts
	width across flats: 5 mm	1	For M6 bolts
	width across flats: 6 mm	1	For M8 bolts
Torque wrench	0.7N.m to 44.0N.m	1	For details, refer to <a href="#">1.2.6 Tightening Bolts/Screws</a> .
Phillips screwdriver	Ph1	1	<a href="#">2.8.2 Replacing the Control Board</a>
	Ph2	1	
Wrench	Opposite sides 5 mm	1	<a href="#">2.9.1 Removing the Cable Unit</a> (For removing D-sub connector)
	Opposite sides 7 mm	1	<a href="#">3.2 Adjusting the Timing Belt Tension</a>
Nut screwdriver	Opposite sides 5 mm	1	<a href="#">2.9.1 Removing the Cable Unit</a> (For removing D-sub connector)
Nipper		1	For cutting wire tie
Spatula		1	For applying grease on the J1/J2 Reduction Gear
Wiping cloth		1	For wiping grease from the J1/J2 Reduction Gear and the Ball Screw Spline
Sonic Belt Tension Meter		1	<a href="#">3.2 Adjusting the Timing Belt Tension</a>
Force gauge		1	<a href="#">3.2 Adjusting the Timing Belt Tension</a>
Suitable cord (Length about 800 mm)		1	<a href="#">3.2 Adjusting the Timing Belt Tension</a>
Screw (M5, About 20 mm in length)		2	For removing the Flexspline of the J1/J2 Reduction Gear

**Materials used**

Name		Quantity	Note
Grease		Proper quantity	For details, refer to <a href="#">1.2.5 Greasing</a> .
Alcohol		Proper quantity	For wiping grease from the J1/J2 Reduction Gear and the Ball Screw Spline
Wire tie	AB100	Proper quantity	Fixing the cables
	AB150		
	AB200		

## 1.2.5 Greasing

The Ball Screw Spline and Reduction Gears need greasing regularly. Only use the specified grease.

 <p>CAUTION</p>	<ul style="list-style-type: none"> <li>■ Keep enough grease in the Manipulator. Operating the Manipulator with insufficient grease will damage sliding parts and/or result in insufficient function of the Manipulator. Once the parts are damaged, a lot of time and money will be required for the repairs.</li> <li>■ If grease gets into your eyes, mouth, or on your skin, follow the instructions below.           <ul style="list-style-type: none"> <li>If grease gets into your eyes: Flush them thoroughly with clean water, and then see a doctor immediately.</li> <li>If grease gets into your mouth: If swallowed, do not induce vomiting. See a doctor immediately.               <ul style="list-style-type: none"> <li>If grease just gets into your mouth, wash out your mouth with water thoroughly.</li> </ul> </li> <li>If grease gets on your skin: Wash the area thoroughly with soap and water.</li> </ul> </li> </ul>
--	--

### Joint #1 and Joint #2 Reduction Gears

As a rough indication, perform greasing at the same timing as overhaul.

However, it may vary depending on usage condition and degree of the load (such as when operated with the maximum motion speed and maximum acceleration / deceleration in continuous operation) applied on the Manipulator.

For details, refer to [2.2.6 Installing the J1 Reduction Gear Unit](#), [2.3.6 Installing the J2 Reduction Gear Unit](#)

### Joint #3 Ball Screw Spline Unit

The recommended greasing interval is at 100 km of operation. However, greasing timing also can be checked from the grease condition. Perform greasing if the grease is discolored or becomes dry.

Perform greasing at 50 km of operation for the first time of greasing.

For details, refer to [2.7.3 Greasing the Ball Screw Spline Unit](#)



Normal grease

Discolored grease

#### NOTE

For the EPSON RC+ 7.0 Ver. 7.2.x or later (firmware Ver.7.2.x.x or later), the recommended replacement time for the grease on the Ball Screw Spline Unit can be checked in the [Maintenance] dialog box of the EPSON RC+ 7.0.

## Grease or adhesives used during maintenance

The location and amount of use are specified on the maintenance page of each part.

Only use the grease specified in the following table.

Type	Target Part
SK-1A	Joint #1 / #2 Reduction Gears
Krytox GPL-224	Joint #1 / #2 Internal cables
THK AFB	Ball Screw Spline

The manufacturer and URL details of each grease type are as follows:

Product name: THK AFB-LF Grease  
 Manufacturer: THK CO., LTD.  
 URL: <https://www.thk.com/>

Product name: Harmonic Grease SK-1A  
 Manufacturer: Harmonic Drive Systems Inc.  
 URL: <https://www.harmonicdrive.net/>

Product name: Krytox®GPL-224  
 Manufacturer: Chemours  
 URL: <https://www.chemours.com/en/brandsand-products>

## 1.2.6 Tightening Bolts/Screws

Hexagon socket head cap screws are used in places where mechanical strength is required. (A hexagon socket head cap screw may be called a "bolt" in this manual.) These bolts/screws are fastened with the tightening torques shown in the following table.

When it is necessary to refasten these bolts/screws in some procedures in this manual (except special cases as noted), use a torque wrench so that the bolts/screws are fastened with the appropriate tightening torques as shown below.

In the manual, the bolts and screws to be removed (attached) during maintenance are specified as follows:

Example) S01: 6-M4×15

S01 indicates the "Type" in the table below. Be sure to tighten with the correct tightening torque after confirming the "Type" and "Size".

Type	Description	Size	Tightening torque (N.m)
S01	Hexagon socket head cap screw (silver)	M2.5	1.0 +/- 0.1
		M3	2.0 +/- 0.1
		M4	4.0 +/- 0.2
		M5	8.0 +/- 0.4
		M6	13.0 +/- 0.6
		M8	32.0 +/- 1.6
S02	Hexagon socket head cap screw (black) (Reduction Gear, etc.)	M5	10.0 +/- 0.5
		M8	44.0 +/- 2.2
S03	Cross recessed pan head screw (Covers and Circuit boards, etc.)	M2	0.2 +/-0.03
		M3	0.45 +/- 0.1
		M4	0.45 +/- 0.1
S04	Cross recessed pan head screw (Ground Wires, etc.)	M4	0.9 +/- 0.1
S05	Hexagon socket head set screw	M3	0.7 +/- 0.1
		M4	2.4 +/- 0.1
		M5	4.0 +/- 0.2

We recommend that the bolts aligned on a circumference should be fastened in a crisscross pattern as shown in the figure below.

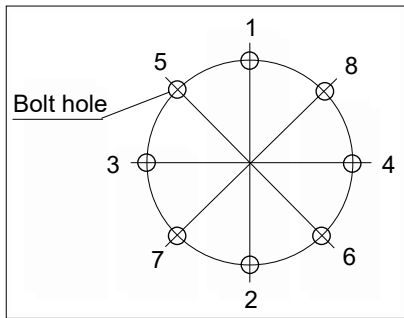

Do not fasten all bolts securely at one time. Divide the number of times that the bolts are fastened into two or three and fasten the bolts securely with a hexagonal wrench. Then, use a torque wrench so that the bolts are fastened with tightening torques shown in the table above.



### **1.2.7 Matching Origins**

After parts have been replaced (motors, Reduction Gears, etc.), the Manipulator cannot operate properly because a mismatch exists between the origin stored in each motor and its corresponding origin stored in the Controller.

After replacing the parts, perform the calibration to match these origins.

For details, refer to [3.1 Calibration](#).

## 1.3 Parts Layout

### 1.3.1 Table Top Mounting

**GX20-B\*\*\*S : Standard model**

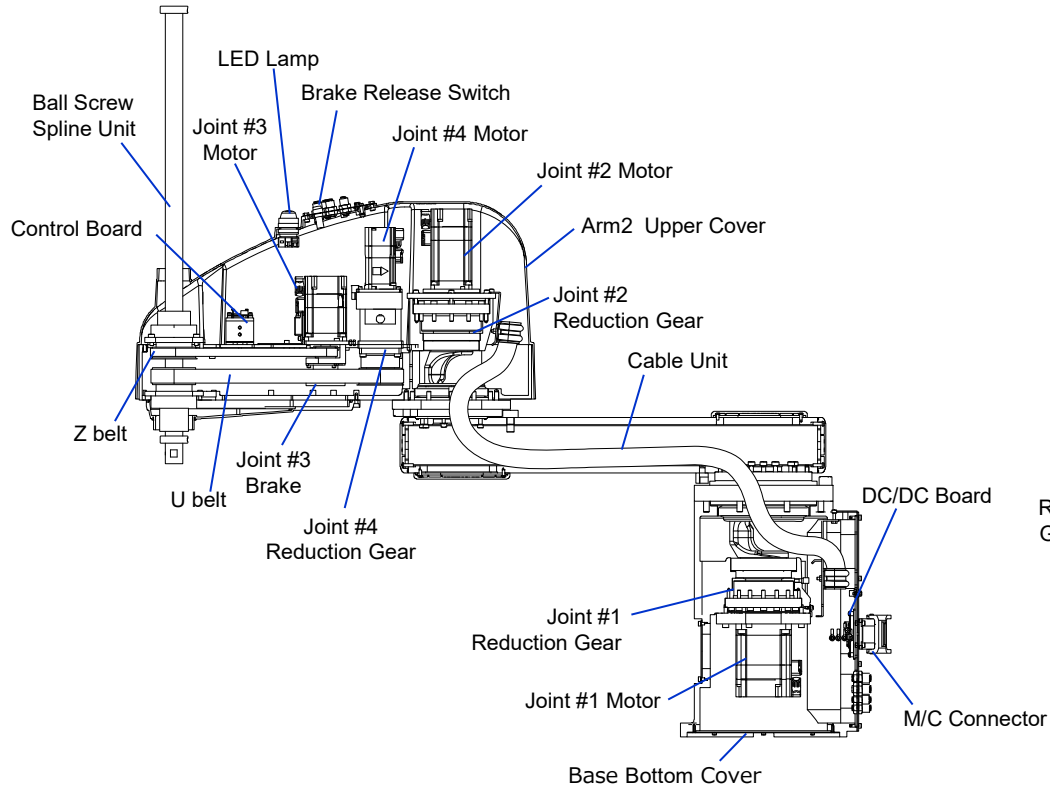

**GX20-B\*\*\*C : Cleanroom & ESD (anti-static) model**

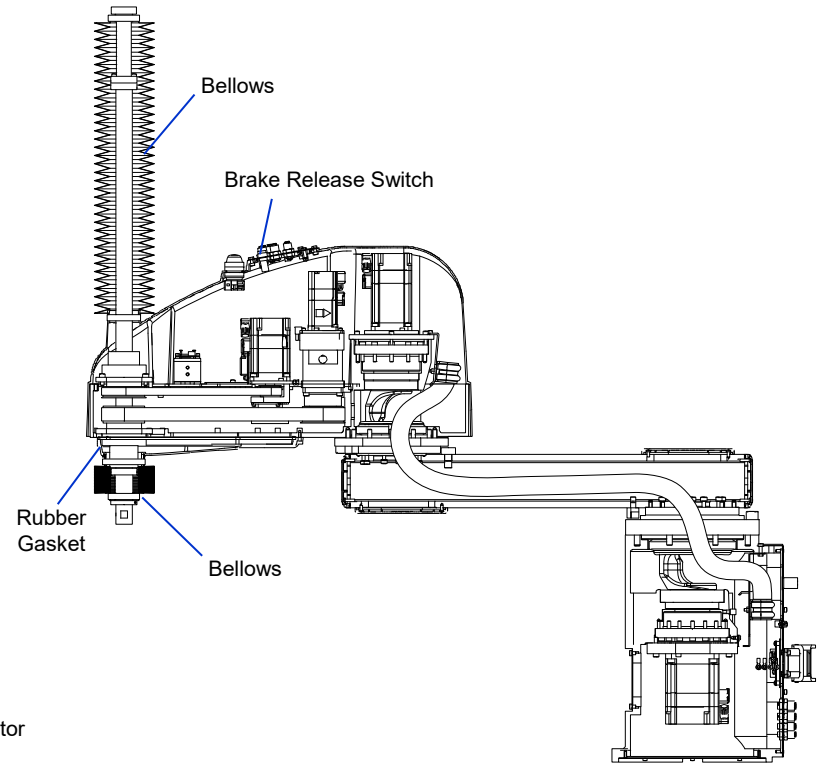

GX20-B\*\*\*P : Protected model

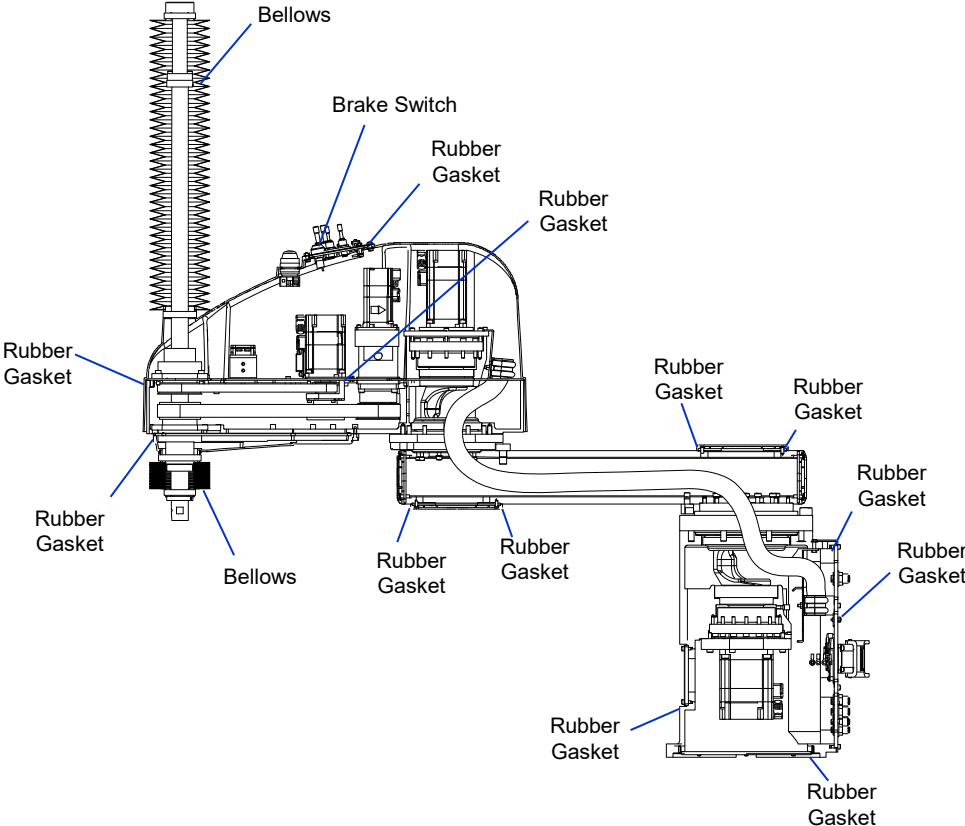

### 1.3.2 Wall Mounting

**GX20-B\*\*\*SW : Standard model**

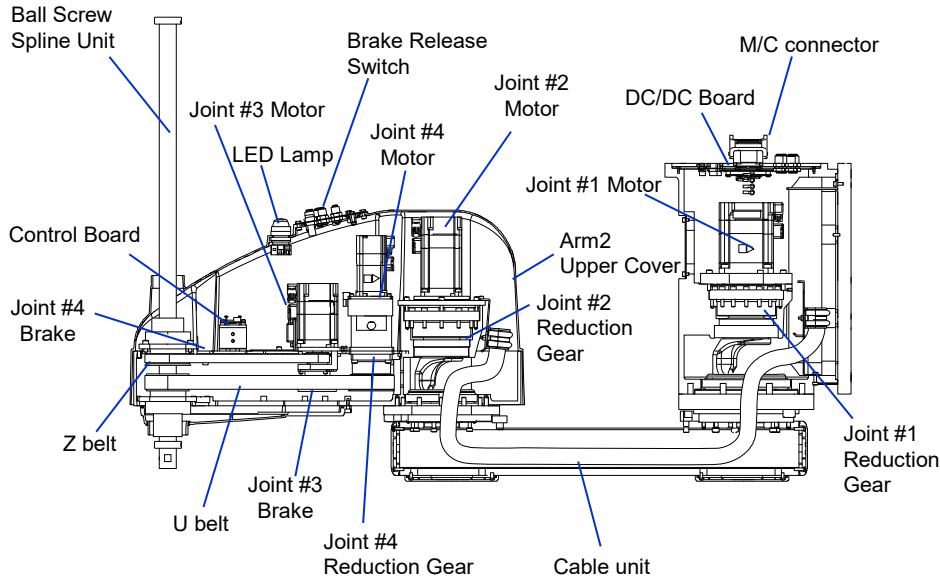

**GX20-B\*\*\*CW : Cleanroom & ESD (anti-static) model**

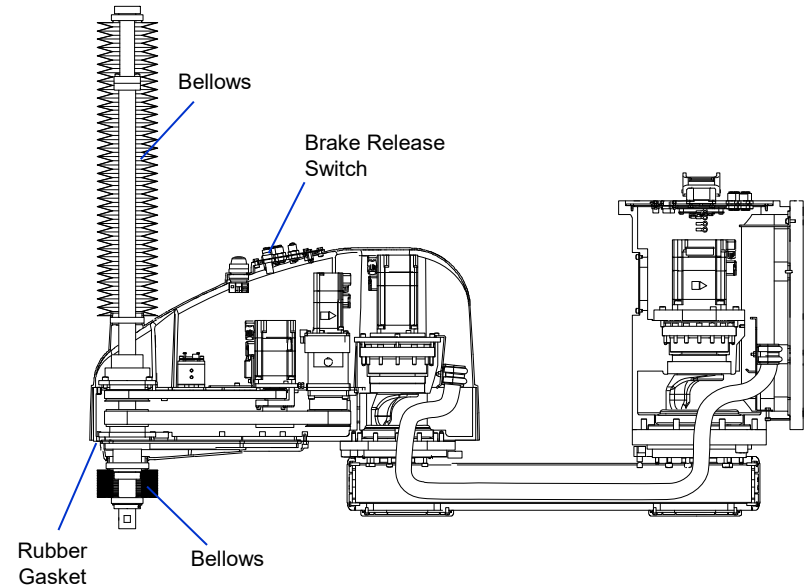

**GX20-B\*\*\*PW : Protected model**

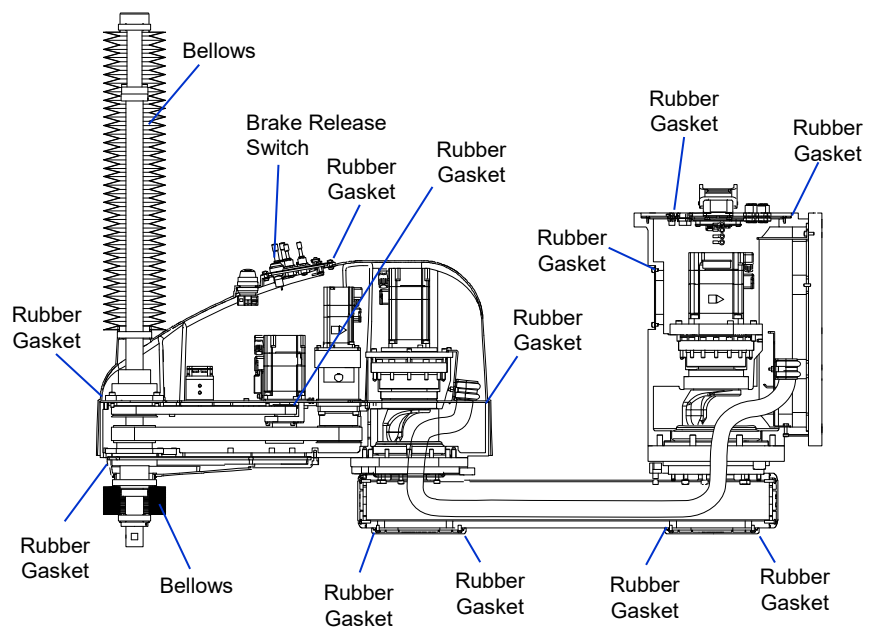

### 1.3.3 Ceiling Mounting

**GX20-B\*\*\*SR : Standard model**

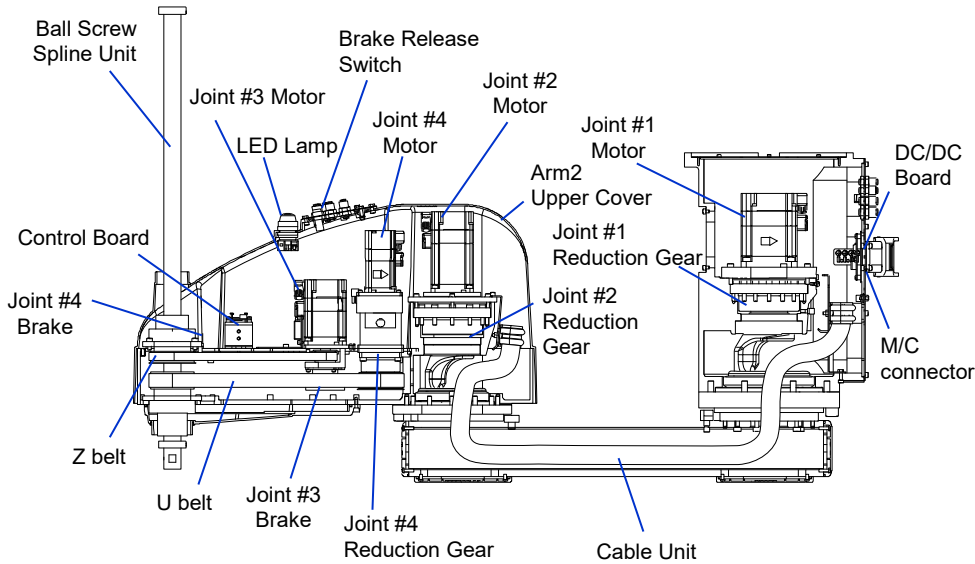

**GX20-B\*\*\*CR : Cleanroom & ESD (anti-static) model**

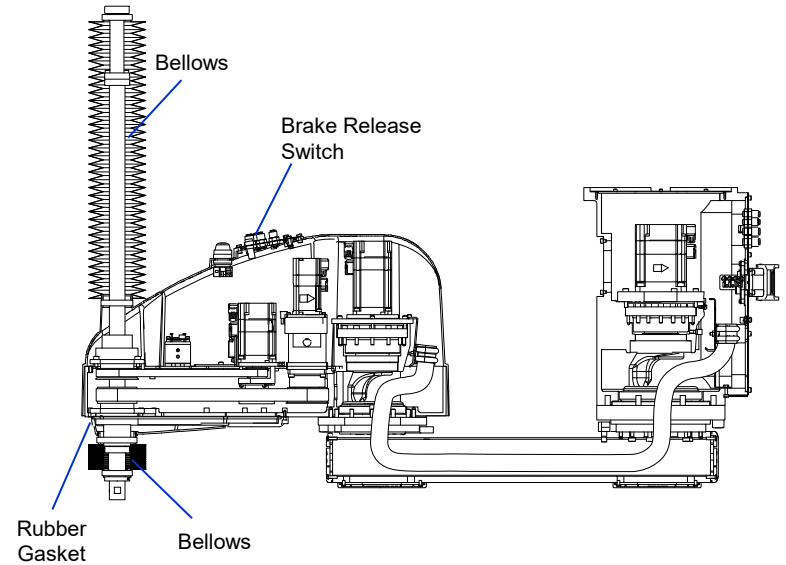

GX20-B\*\*\*PR : Protected model

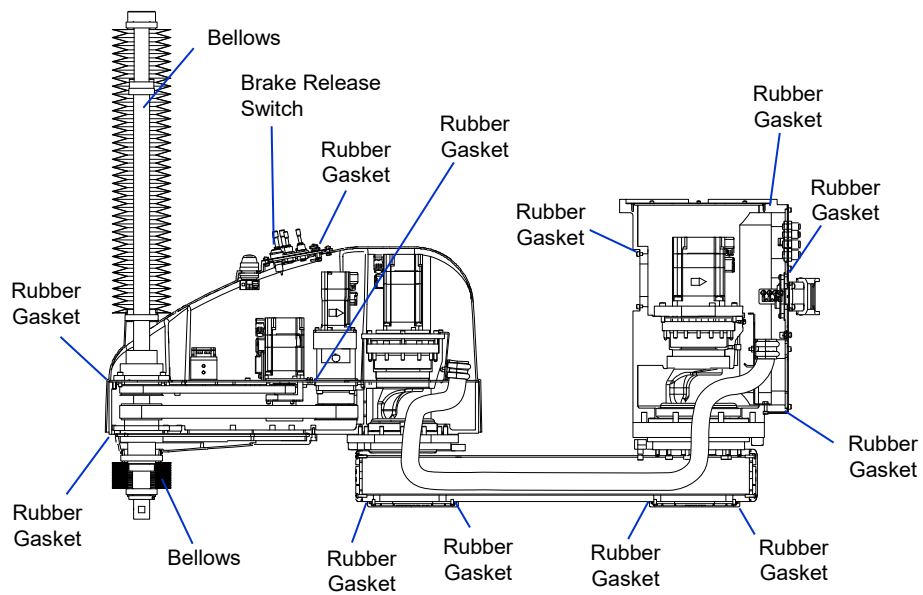

## 1.4 Differences from the Table Top Mounting

### 1.4.1 Base Bottom Cover/Bottom Connector Unit

Table top mounting : GX20-B\*\*\*S  
Ceiling Mounting : GX20-B\*\*\*SR

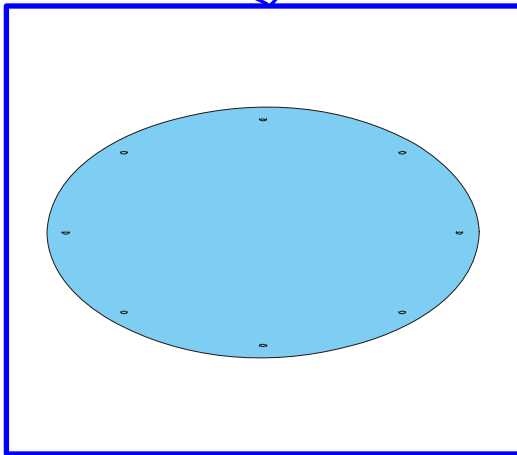
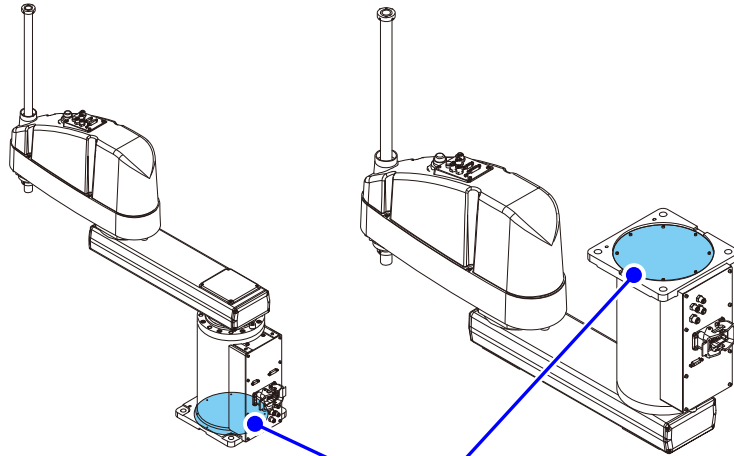

Wall Mounting : GX20-B\*\*\*SW

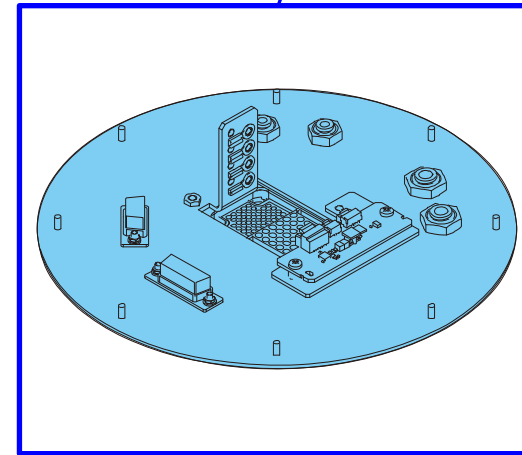
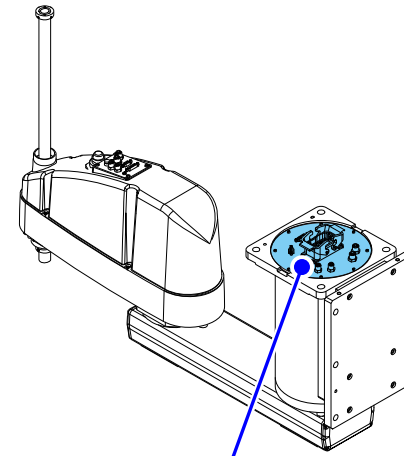



### 1.4.2 Connector Plate/Wall Mounting Plate

Table top mounting : GX20-B\*\*\*S  
Ceiling Mounting : GX20-B\*\*\*SR

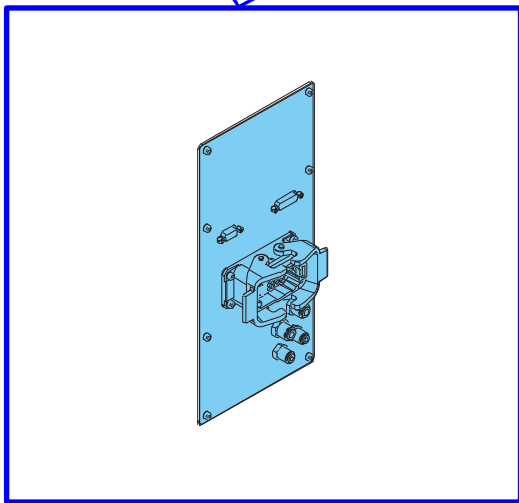
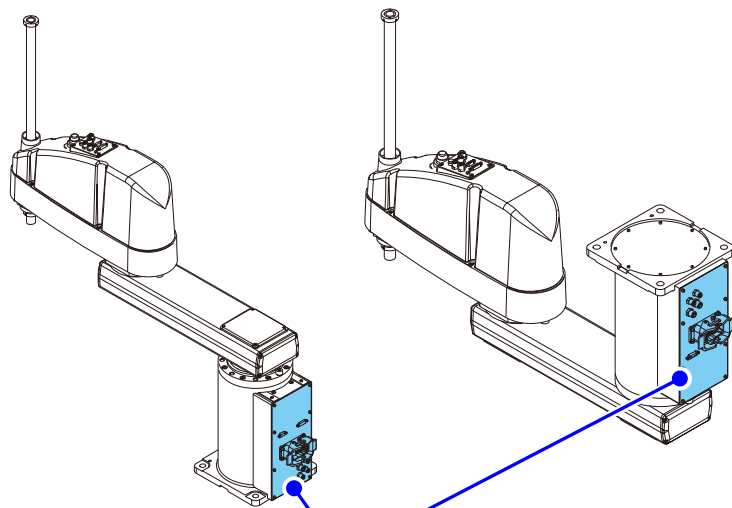

Wall Mounting : GX20-B\*\*\*SW

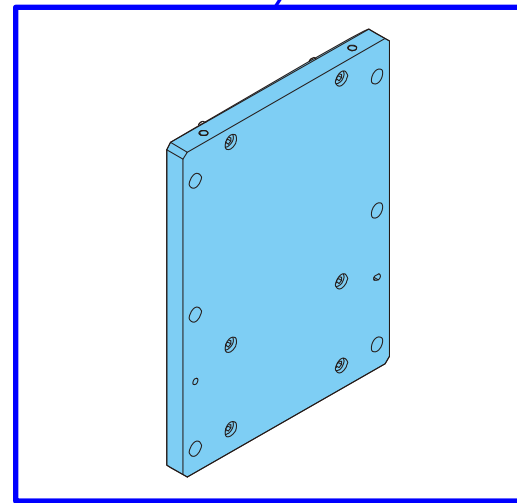
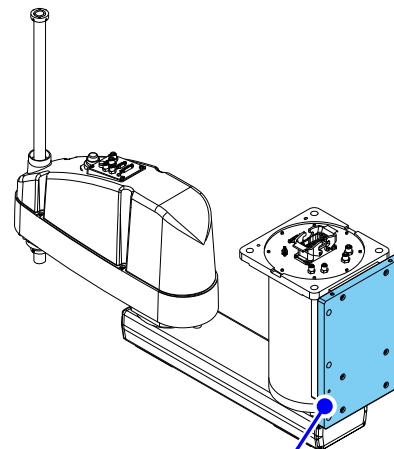

### 1.4.3 Base Unit

Table top mounting : GX20-B\*\*\*S

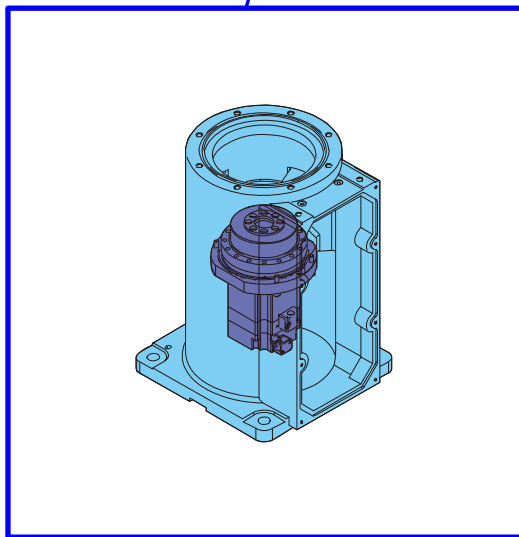
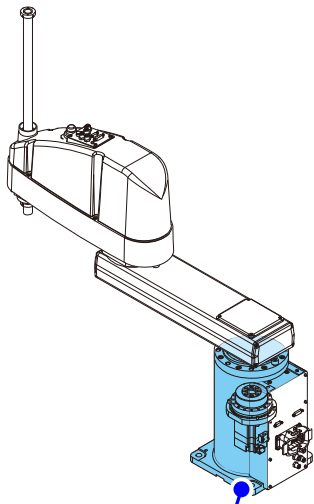

Wall Mounting : GX20-B\*\*\*SW  
Ceiling Mounting : GX20-B\*\*\*SR

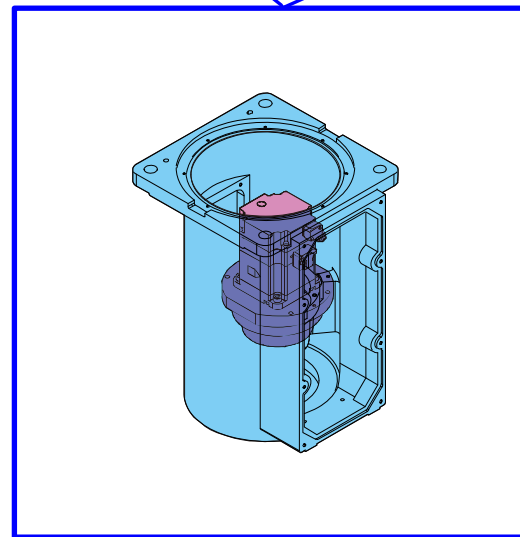
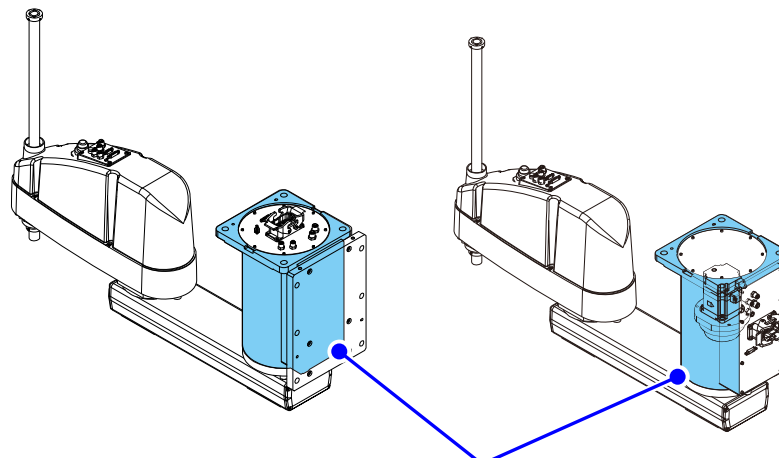

### 1.4.4 Arm 1 Unit

Table top mounting : GX20-B\*\*\*S

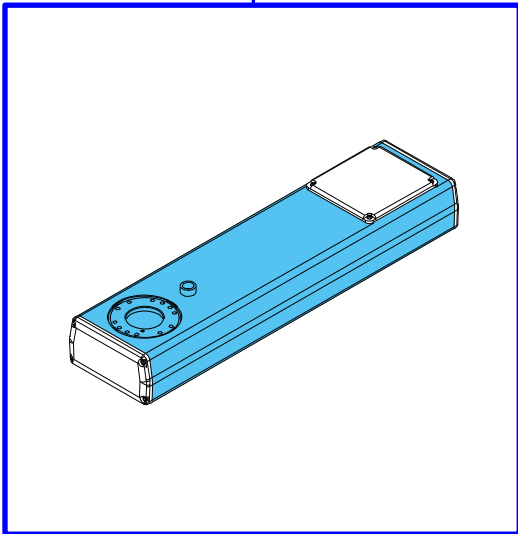
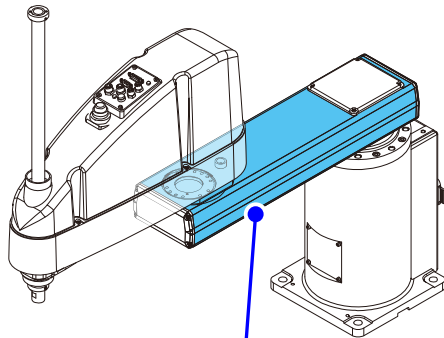

Wall Mounting : GX20-B\*\*\*SW  
Ceiling Mounting : GX20-B\*\*\*SR

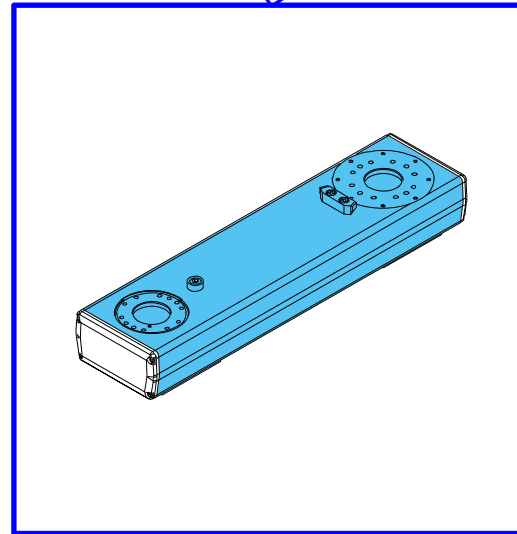
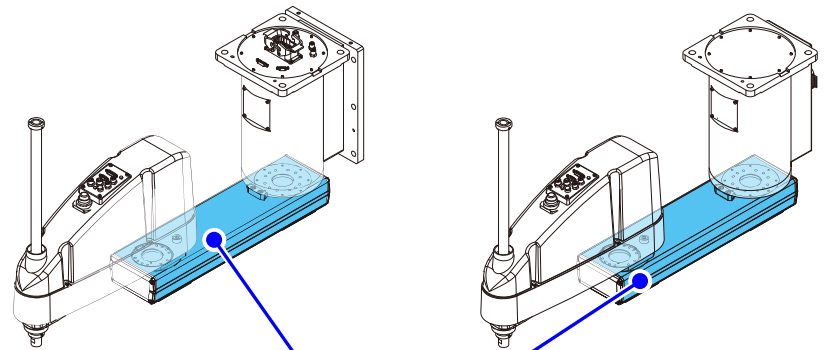

CHAPTER

2

# Maintenance

## 2.1 Overview

---

### 2.1.1 Precautions for Maintenance

- Perform disassembly and assembly according to the procedures described in the manual.
- Some parts are managed by serial number. Before installing parts, make sure that the serial number of each part matches. Using parts with different serial numbers may result in vibrations, abnormal noise, or other issues that may affect the accuracy of the robot.
  
- Remove connectors by releasing the latch. When connecting connector, make sure the latch is closed.
- Do not pull the connector or cable with force. Doing so may cause damage.
- When fixing the covers and plates, be careful not to pinch the cables.
- When cutting a wire tie, be careful not to damage the cables.
- Installation of a Silicone Sheet or securing with a wire tie are measures to prevent pulling or grazing of the cable when the robot moves, and also to prevent friction between connectors. Use the Silicone Sheet and wire tie according to the instructions in the manual to fix the cables.
- Make sure that the wire tie is not over-tightened with force.
  
- When tightening bolts or screws, use the correct tightening torque. For details, refer to [1.2.6 Tightening Bolts/Screws](#).
- Fasten the bolts aligned on a circumference in a crisscross pattern. For details, refer to [1.2.6 Tightening Bolts/Screws](#).
  
- When removing or replacing parts related to the belt, be sure to adjust the tension of the Timing Belt.  
For details, refer to [3.2 Adjusting the Timing Belt Tension](#).
  
- Before applying grease, wipe off the old grease and anti-rust oil. If any old grease is left behind, the lubrication may deteriorate, the anti-rust oil may harden, and the robot accuracy may be affected.
- Apply the specified amount of grease to the parts specified in the manual.
- When applying grease, take care that the grease does not adhere on to the surrounding parts. Oil separation of the surrounding grease may result in oil leakage. Therefore, be sure to wipe off any adhering grease.

## 2.1.2 Viewing the Maintenance Page

Each page is configured as shown below.

The work procedures are shown below.

### Viewing the steps

**Step 4** ← Work sequence  
**Arm2** ← Target part name  
**S02: 16-M3x20** ← Screw type

### About the screw type

**S01** indicates the screw type. For details on the type, the size, torque value, etc., refer to [1.2.6 Tightening Bolts/Screws](#).

### Color classification/symbols of steps

If the work procedures are described on multiple pages, the color classification is performed as follows:

**Step 4** The work procedures are described on the page being browsed.  
**Arm2**

**Step 3** The work procedures are not described on the page being browsed. (In this example, the O-ring tasks are described on the page before the page being browsed.)  
**O-ring**

If the details of a work and the precautions for work are described, the step and the description items are connected by a line.

**Step 4**   
**Arm2**

If the following icon is added to a step, the work procedures are described on another page. Clicking the icon will open the corresponding page.

**Step 5**   
**Joint #2 Motor unit**

You can return to the original page by simultaneously pressing the [Alt] key and the [←] key.  
 \* The operation method may differ depending on the viewer.  
 For details, refer to Help of each viewer.

### CAUTION

Indicates information about risks which may cause injury to persons and risks which the Manipulator functions cannot be implemented.

### POINT

Indicates a method of proceeding with work in an efficient manner.

### NOTE

Indicates information not concerning the work procedures.

### 2.3.6 Installing the J2 Reduction Gear Unit

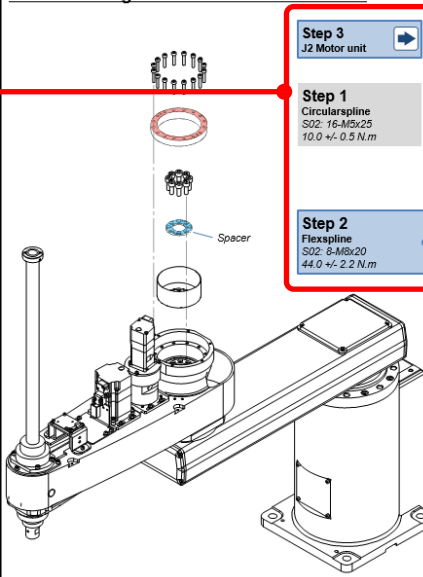

**Step 1**  
Circularspline  
S02: 16-M5x25  
10.0 +/- 0.5 N.m

**Step 2**  
Flexspline  
S02: 8-M8x20  
44.0 +/- 2.2 N.m

3. Set the Spacer with the positions of its air holes aligned with the tapped holes of the Flexspline. Secure the Flexspline and Spacer to Arm2.

**CAUTION**  
Install the Spacer so that its air holes align with the tapped holes of the Flexspline. When the air holes are not in alignment, move Arm2 to the left and right to bring them into alignment. If the Spacer and Flexspline are installed incorrectly, this may cause pressure inside the Reduction Gear to rise and oil to leak.

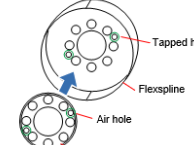

4. Apply grease to the inside of the Flexspline.

**SK-1A: 43 g**  
Grease

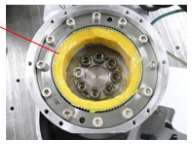

**CAUTION**  
After assembling the motor unit, perform calibration of Joint #2.  
[3.1 Calibration](#)

The configuration of parts to be removed/attached is shown by illustrations.

The details of the work, precautions for work, and points, etc., are described.

Clicking the underlined blue characters will open the corresponding page. You can return to the original page by simultaneously pressing the [Alt] key and the [←] key.  
 \* The operation method may differ depending on the viewer. For details, refer to Help of each viewer.

## 2.2 Joint #1

### 2.2.1 Removing the J1 Motor Unit

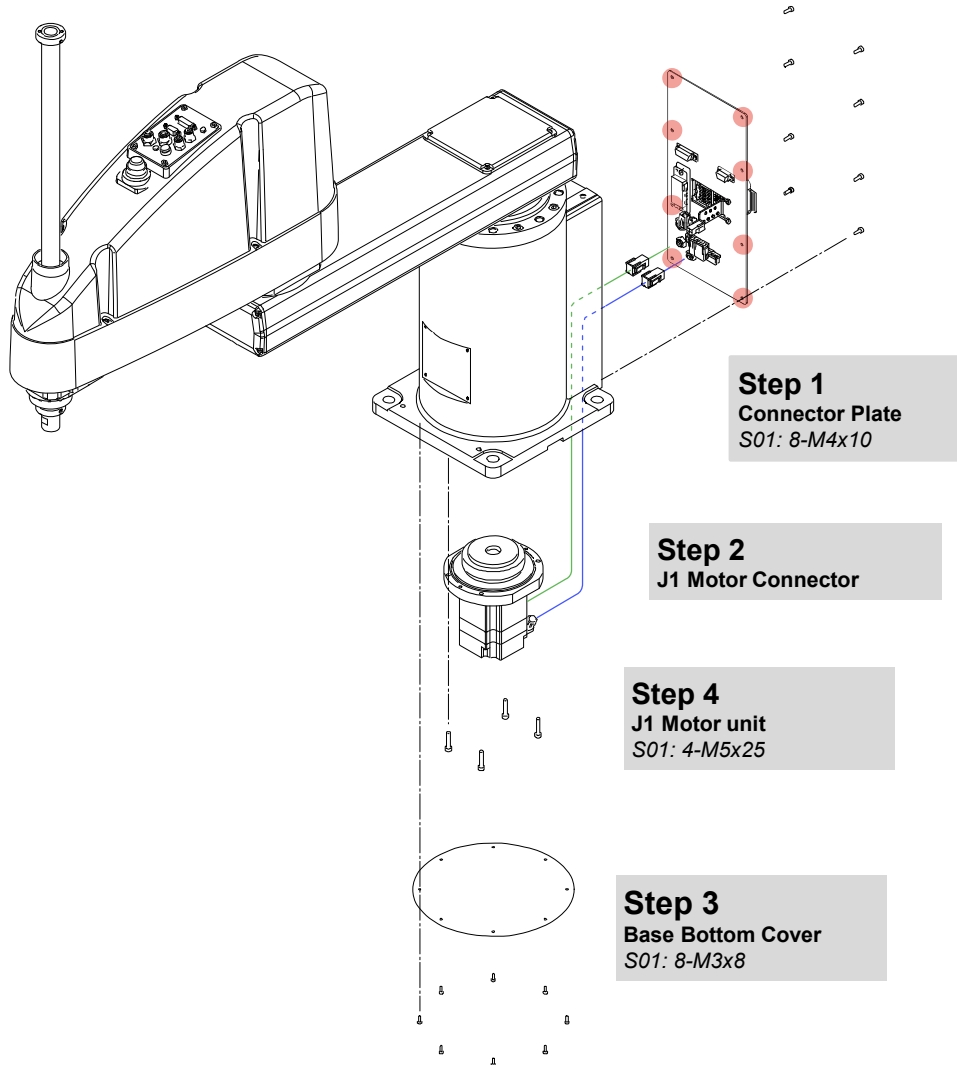

#### Preparation

Remove the Manipulator from the table top, ceiling, wall, or other surface to which it is secured, and then lay the manipulator on its side.

#### CAUTION

Use at least two persons to lift and turn the manipulator. Arm #1 and Arm #2 must be supported to prevent falling or accidental movement which may cause damage or injury.

## 2.2.1 Removing the J1 Motor Unit

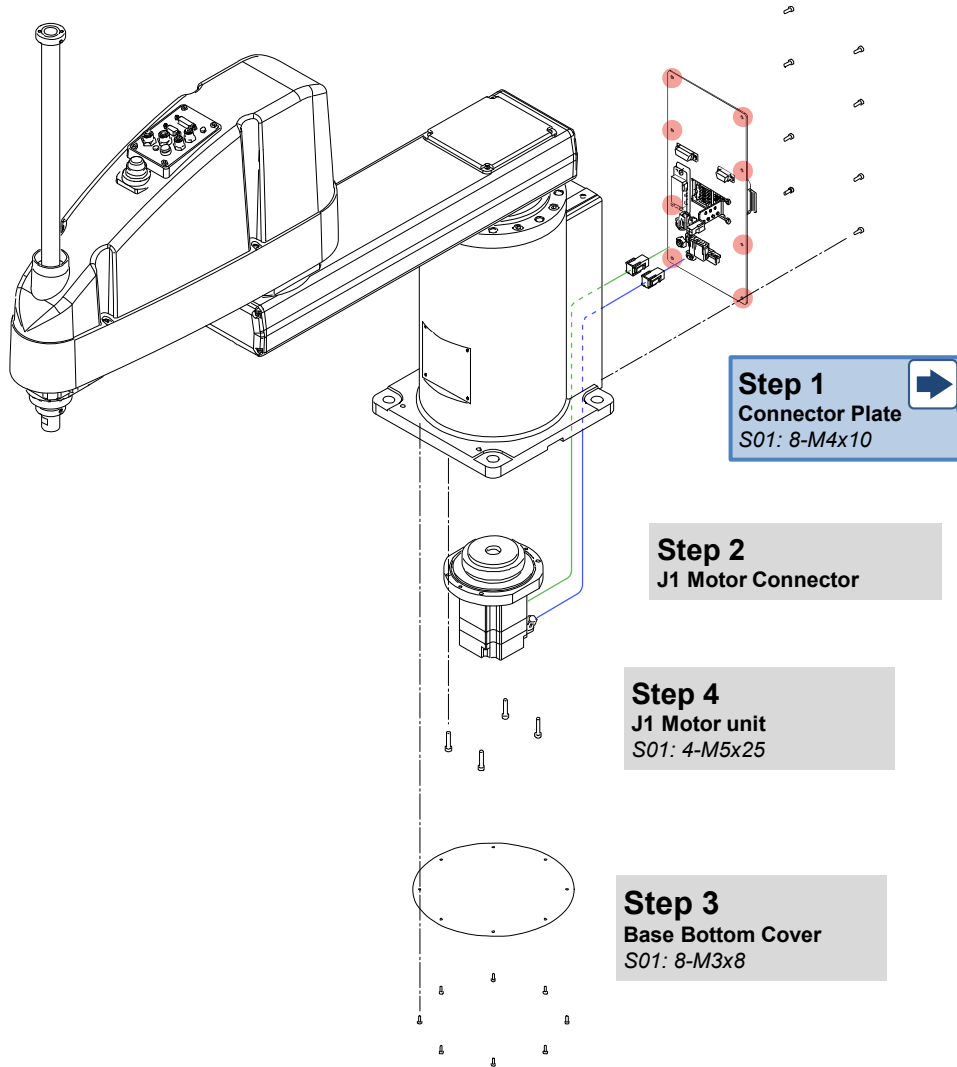

### Removing the Wall Mounting Type/Ceiling Mounting Type

Remove the Manipulator from the table top, lay it on its side, and remove the Connector Plate.

Wall Mounting type

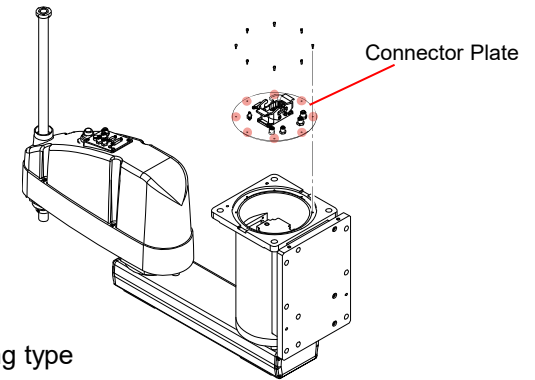

Ceiling Mounting type

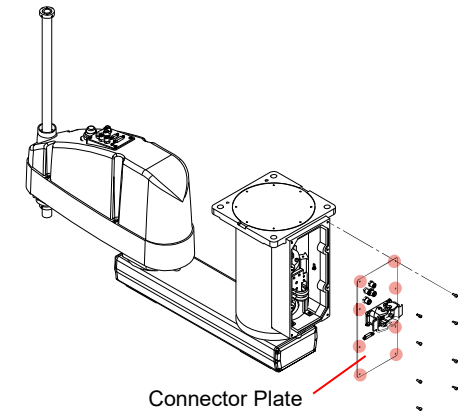

### CAUTION

Use at least two persons to lift and turn the manipulator. Arm #1 and Arm #2 must be supported to prevent falling or accidental movement which may cause damage or injury.



## 2.2.1 Removing the J1 Motor Unit

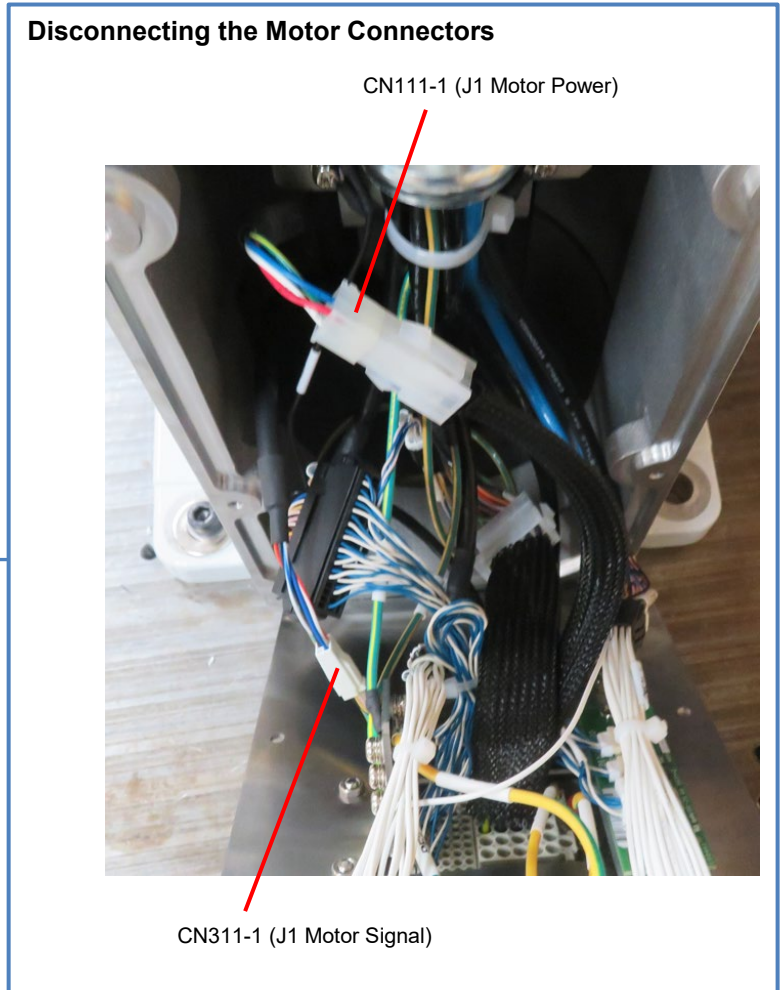
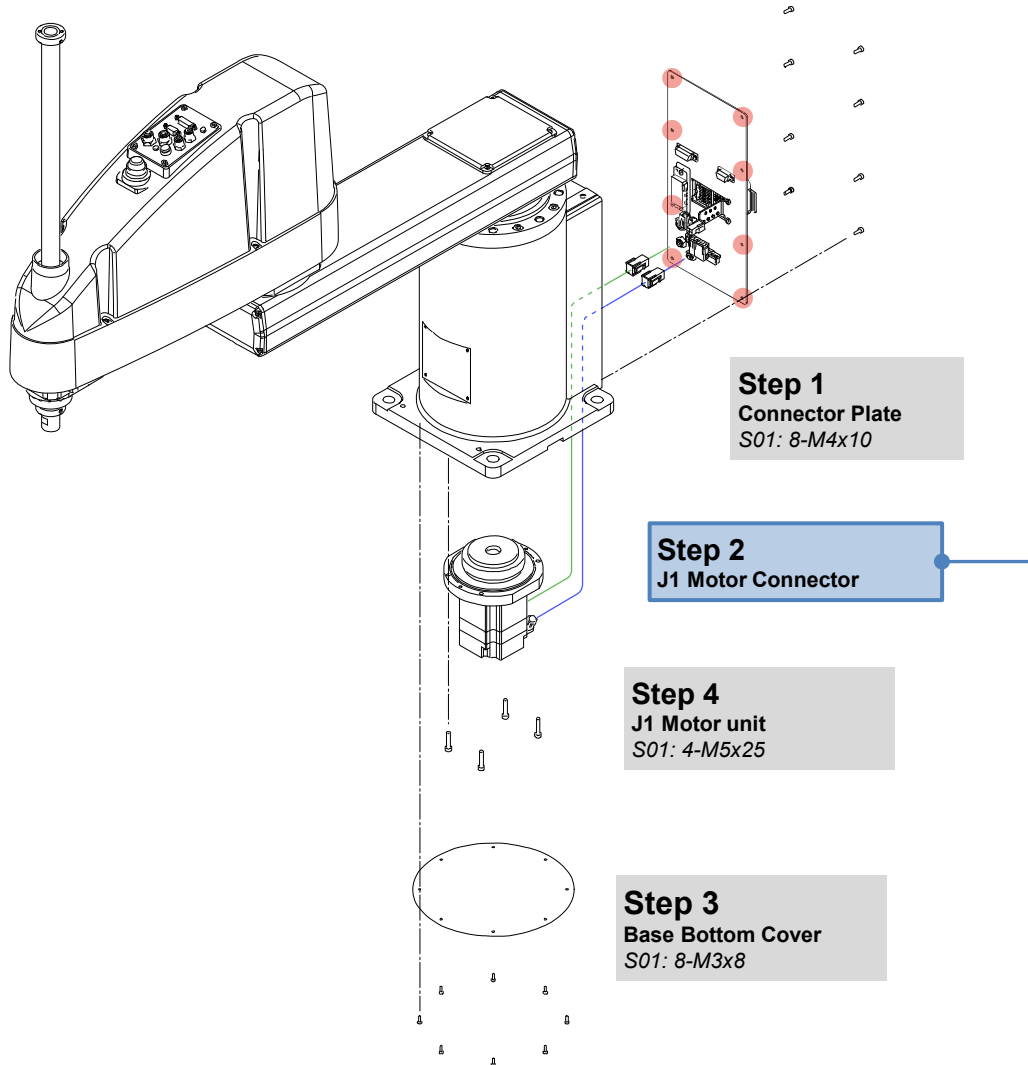

## 2.2.1 Removing the J1 Motor Unit

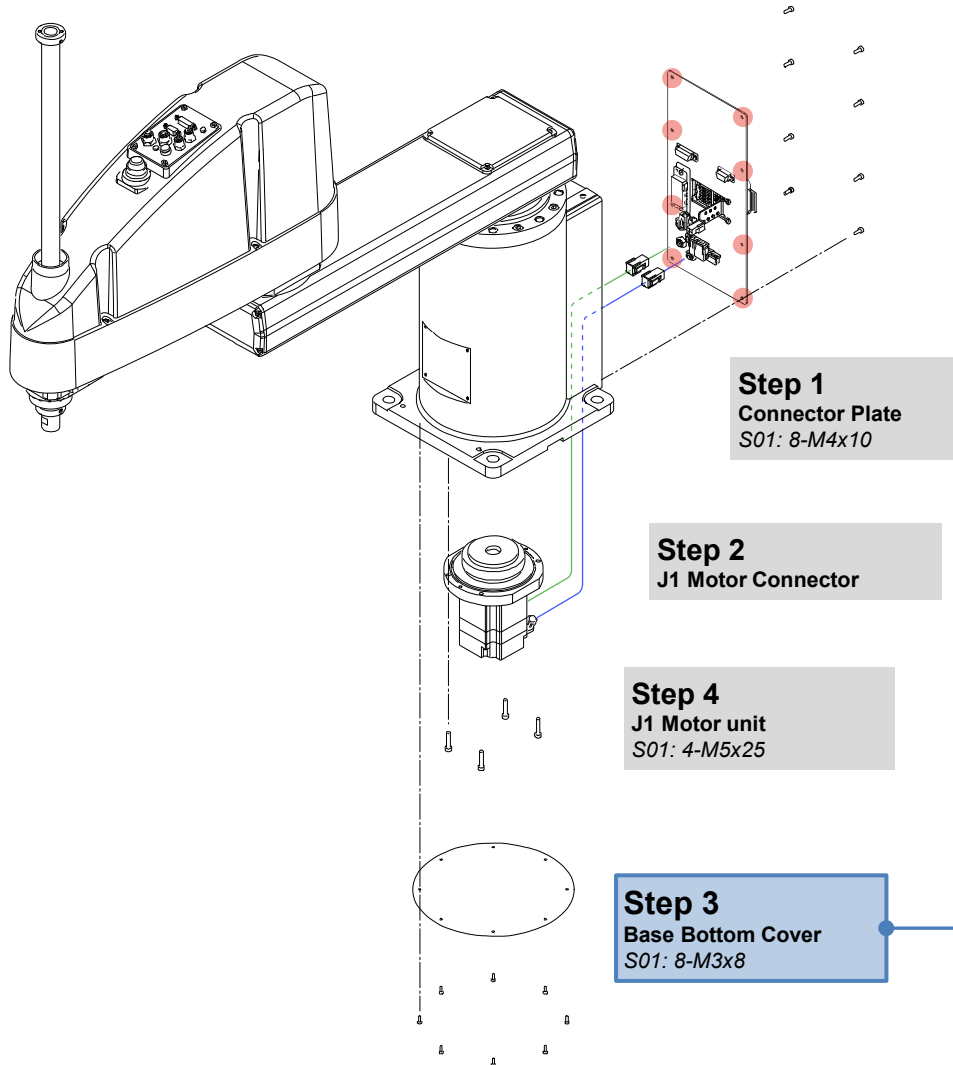

### Table Top Mounting Type/Ceiling Mounting Type

In the case where the cover cannot be removed due to installation, remove the Manipulator from the table top and lay it on its side.

### CAUTION

Use at least two persons to lift and turn the manipulator. Arm #1 and Arm #2 must be supported to prevent falling or accidental movement which may cause damage or injury. If the bolts used for installing the Manipulator to a table top, etc. are removed without the Manipulator being supported, the Manipulator may fall from the arm side due to the arm's own weight.

### Removing the Wall Mounting Type

The Wall Mounting Type does not have a Base Bottom Cover. So, proceed to "Step 4 J1 Motor Unit."

## 2.2.1 Removing the J1 Motor Unit

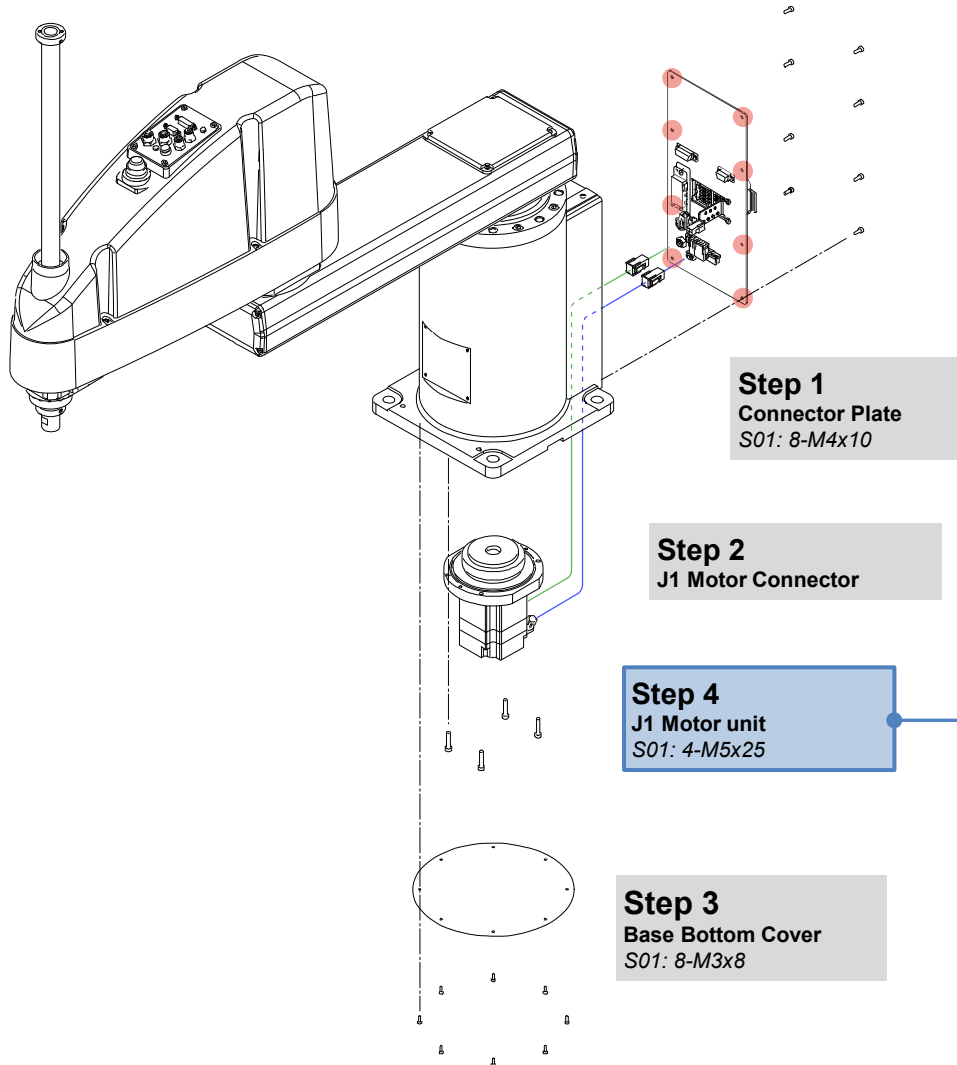

### Removing the J1 Motor Unit

Remove the bolts securing the J1 Motor unit and remove the J1 Motor unit.

#### POINT

- When removing the J1 Motor unit, pull it straight out from the Reduction Gear unit.
- When it is difficult to remove the motor, pull the motor while gently moving Arm1 back and forth.

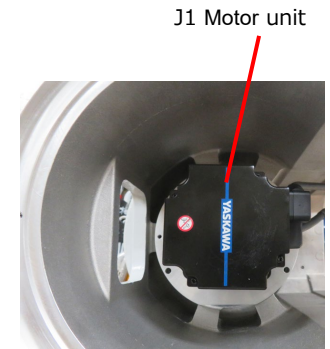
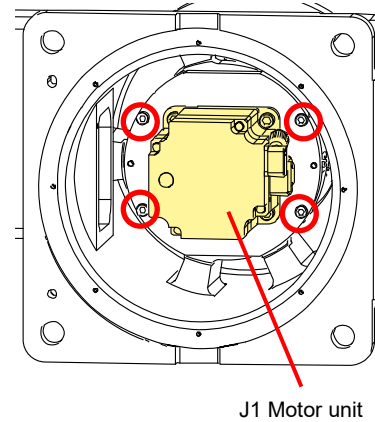

#### CAUTION

- Grease may fall from the Waveform Generator. Take care that it does not adhere onto surrounding parts or peripheral equipment.
- The O-ring on the Motor Plate may come off together with the motor unit. Take care that it does not get damaged or lost.

## 2.2.2 Installing the J1 Motor Unit

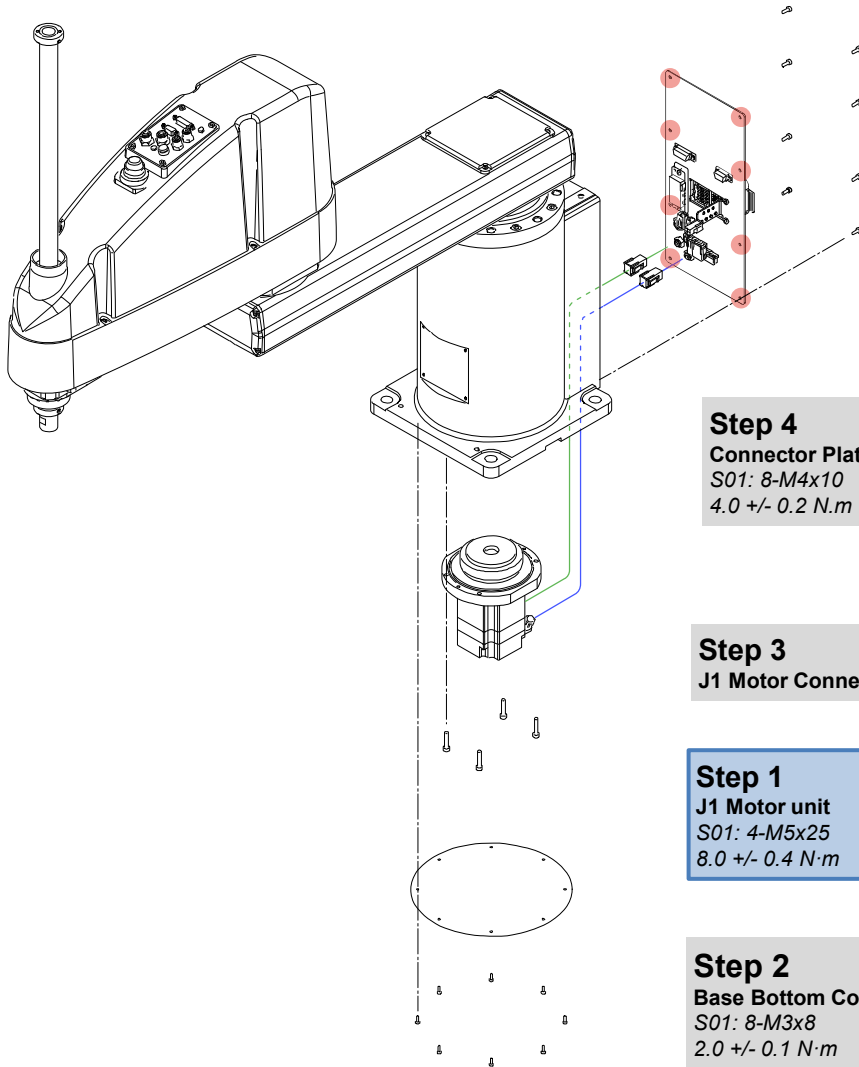

### POINT

Check the longside of the Waveform Generator and Flexspline before applying grease.

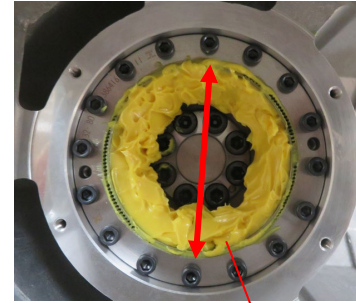
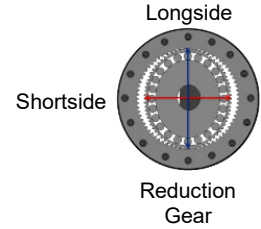

Flexspline

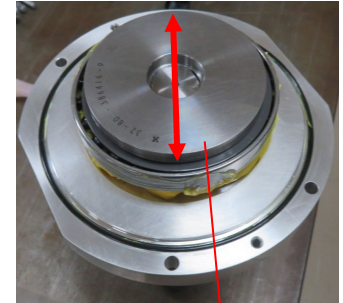

Waveform Generator

### SK-1A 28 g

As shown in the figure, apply grease between the Waveform Generator and Motor Plate.

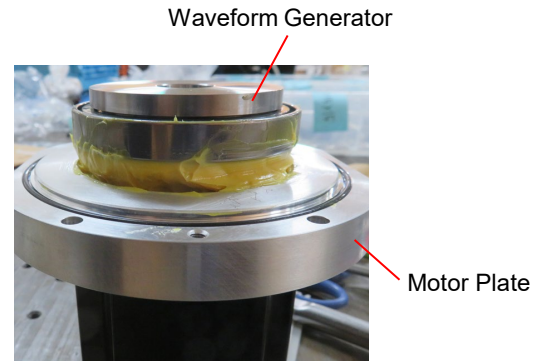

## 2.2.2 Installing the J1 Motor Unit

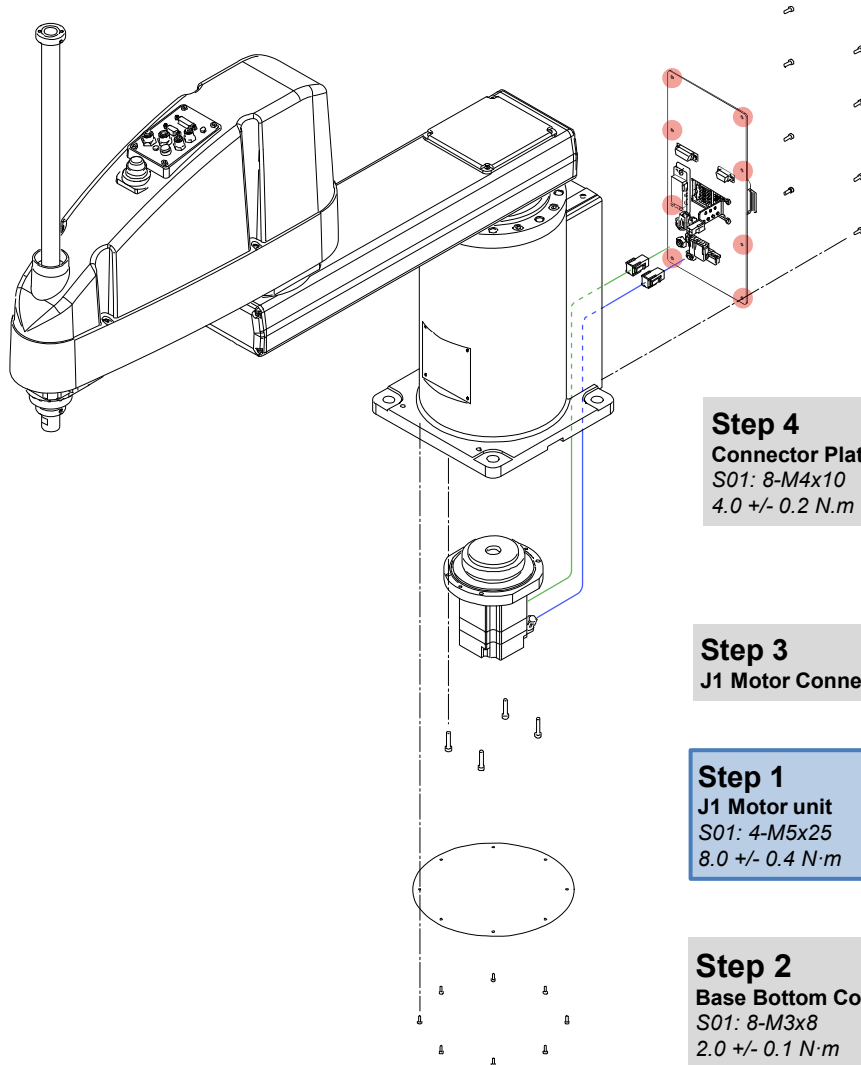

**Step 4**  
**Connector Plate**  
 S01: 8-M4x10  
 4.0 +/- 0.2 N.m

**Step 3**  
**J1 Motor Connector**

**Step 1**  
**J1 Motor unit**  
 S01: 4-M5x25  
 8.0 +/- 0.4 N.m

**Step 2**  
**Base Bottom Cover**  
 S01: 8-M3x8  
 2.0 +/- 0.1 N.m

**CAUTION**

**Orientation of the Joint #1 Motor Unit**

- Install the motor unit into the base as shown in the figure below so that its motor cable faces the front of the Connector Plate.
- Temporarily tighten the motor plate fixing bolts.

**POINT**

Move Arm1 gently back and forth while pushing the motor unit into the Reduction Gear unit.

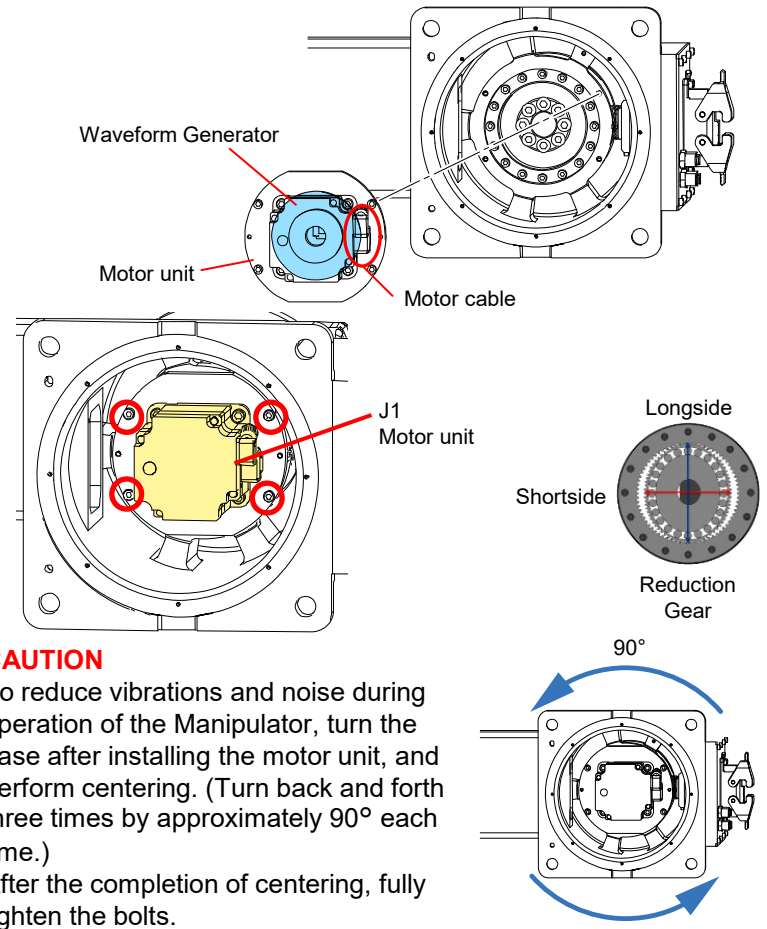

**CAUTION**

To reduce vibrations and noise during operation of the Manipulator, turn the base after installing the motor unit, and perform centering. (Turn back and forth three times by approximately 90° each time.)

After the completion of centering, fully tighten the bolts.



## 2.2.2 Installing the J1 Motor Unit

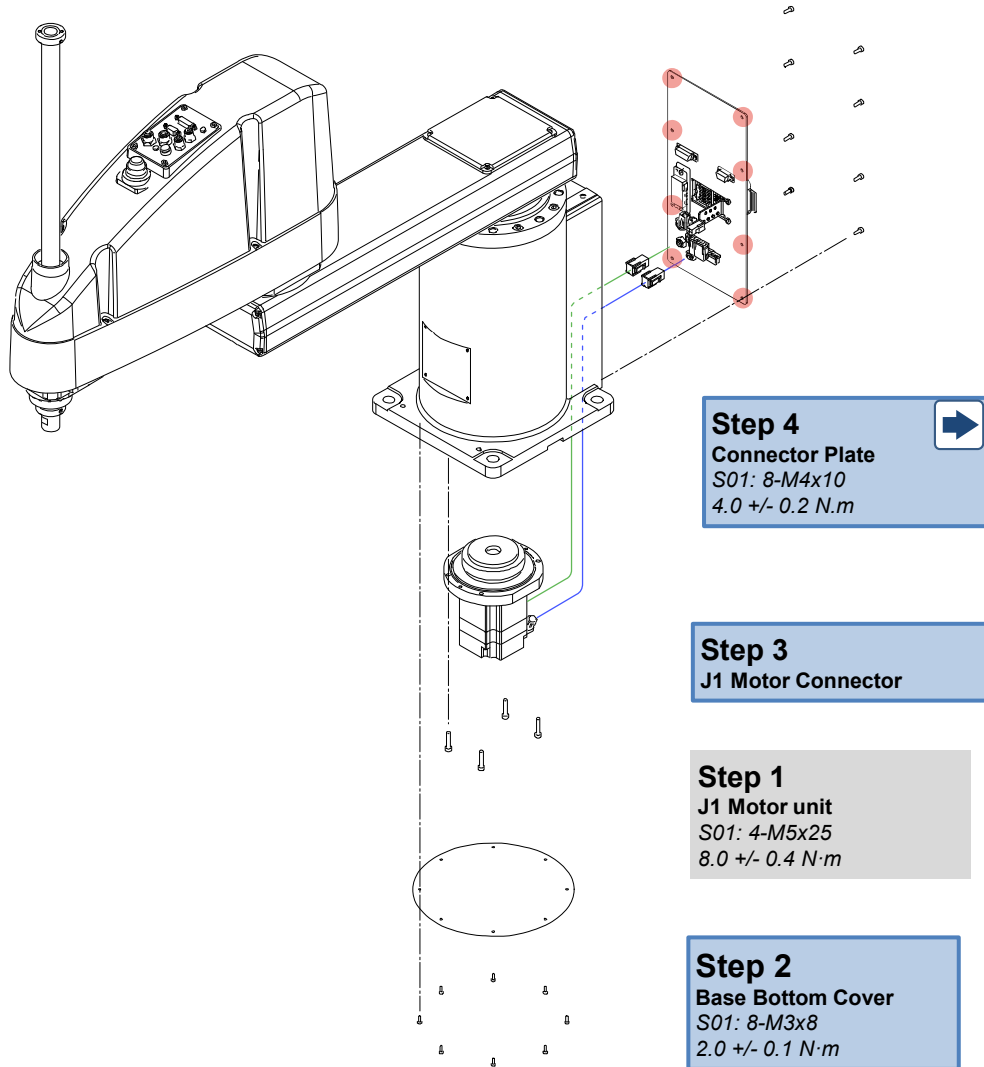

### Connecting the Motor Unit Connectors

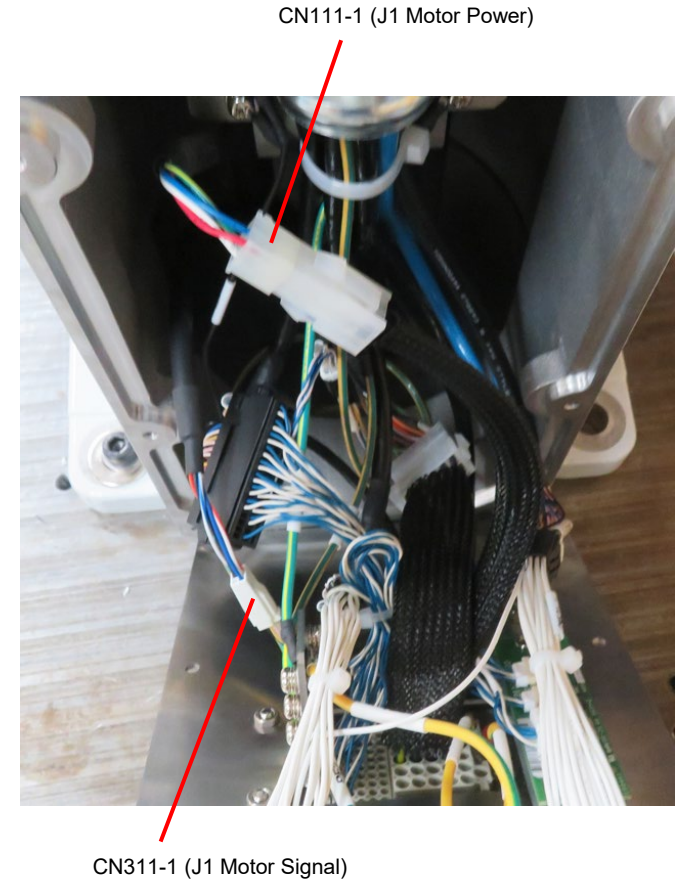

**CAUTION**  
 After assembling the motor unit, perform calibration of Joint #1.  
[3.1 Calibration](#)

### 2.2.3 Disassembling the J1 Motor Unit

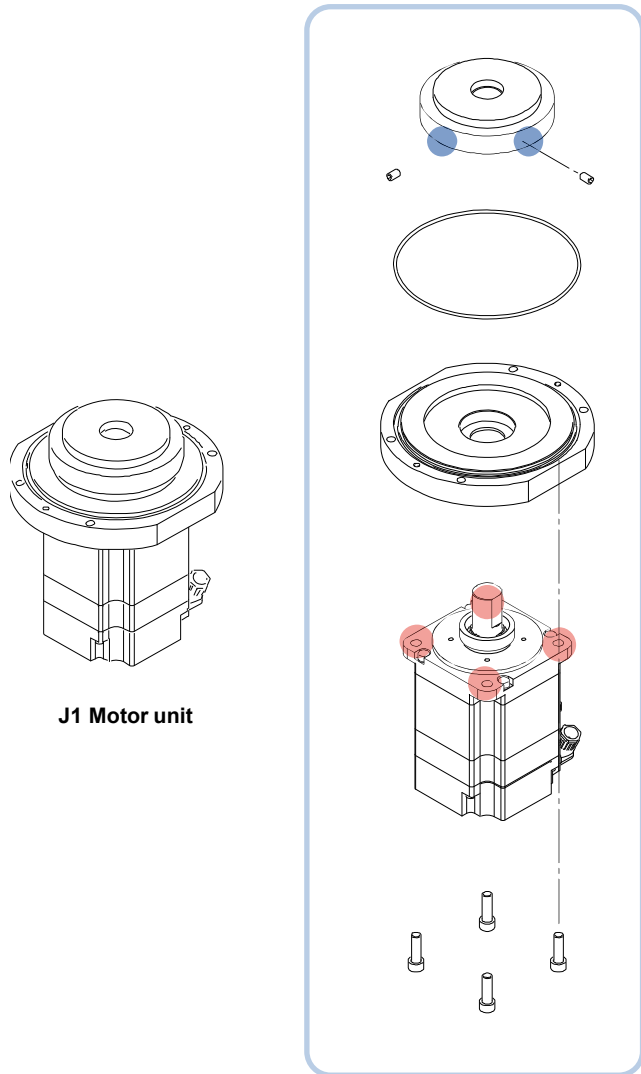

**Step 2**  
Waveform Generator  
S05: 2-M5x8

**Step 1**  
O-ring

**Step 3**  
Motor Plate  
S01: 4-M6x20

**POINT**  
Wipe off the old grease before removing the Waveform Generator from the motor unit.

Waveform Generator

**POINT**  
The O-ring can be removed easily by carefully lifting with a small flat-headed screwdriver.

O-ring

**CAUTION**  
Take care not to damage the O-ring during removal.

**CAUTION**  
An Oil Seal is attached to the Motor Plate. Be careful not to damage the Oil Seal when removing the Motor Plate.

Oil Seal  
Motor Plate

**Notes for Wall Mounting Type/Ceiling Mounting Type**  
The Wall Mounting Type/Ceiling Mounting Type has no Oil Seal because the J1 Motor Unit is attached in the opposite direction and there is no possibility of grease getting inside the motor.

## 2.2.4 Assembling the J1 Motor Unit

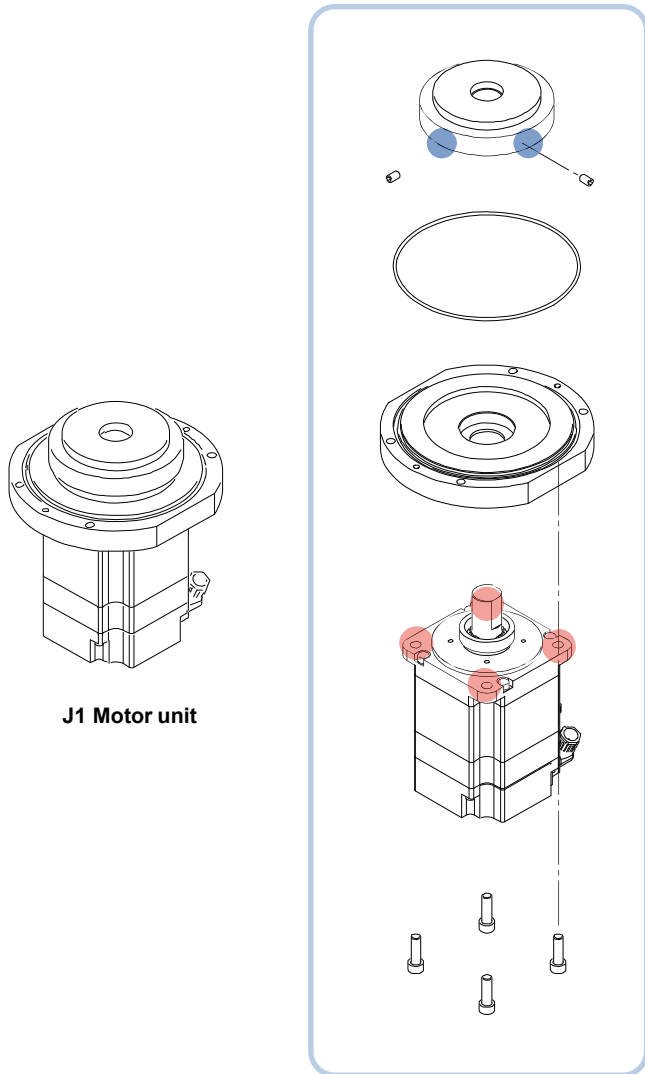

**Step 3**  
**Waveform Generator**  
 S05: 2-M5x8  
 4.0 +/- 0.2 N·m

**Step 2**  
**O-ring**

**Step 1**  
**Motor Plate**  
 S01: 4-M6x20  
 13.0 +/- 0.6 N·m

Fix the J1 Motor and the Motor Plate according to the orientation shown in the figure.

**CAUTION**

Incorrect orientation will result the motor unit cables not being able to be connected correctly.

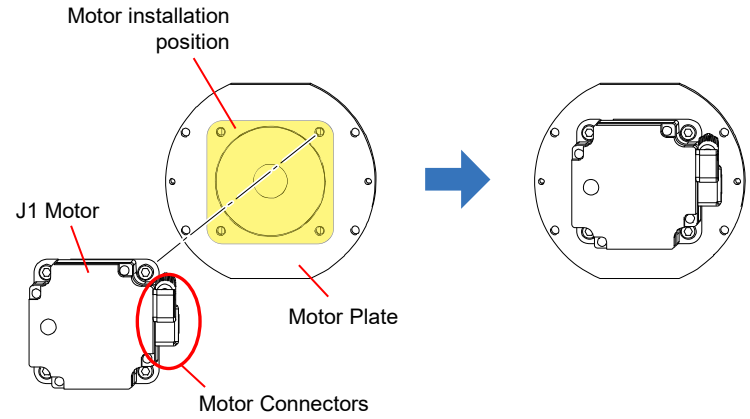

**CAUTION**

Make sure there is no damage such as scratches to the Oil Seal. If the Oil Seal is damaged, oil leakage may occur. If damage is present, replace with a new one.

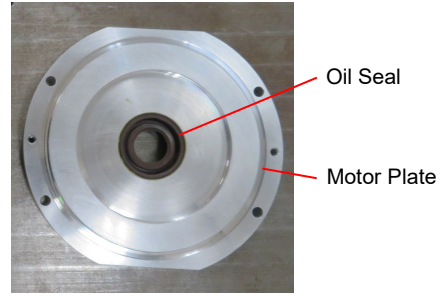

**Notes for Wall Mounting Type/Ceiling Mounting Type**

The Wall Mounting Type/Ceiling Mounting Type has no Oil Seal because the J1 Motor Unit is attached in the opposite direction and there is no possibility of grease getting inside the motor.



## 2.2.4 Assembling the J1 Motor Unit

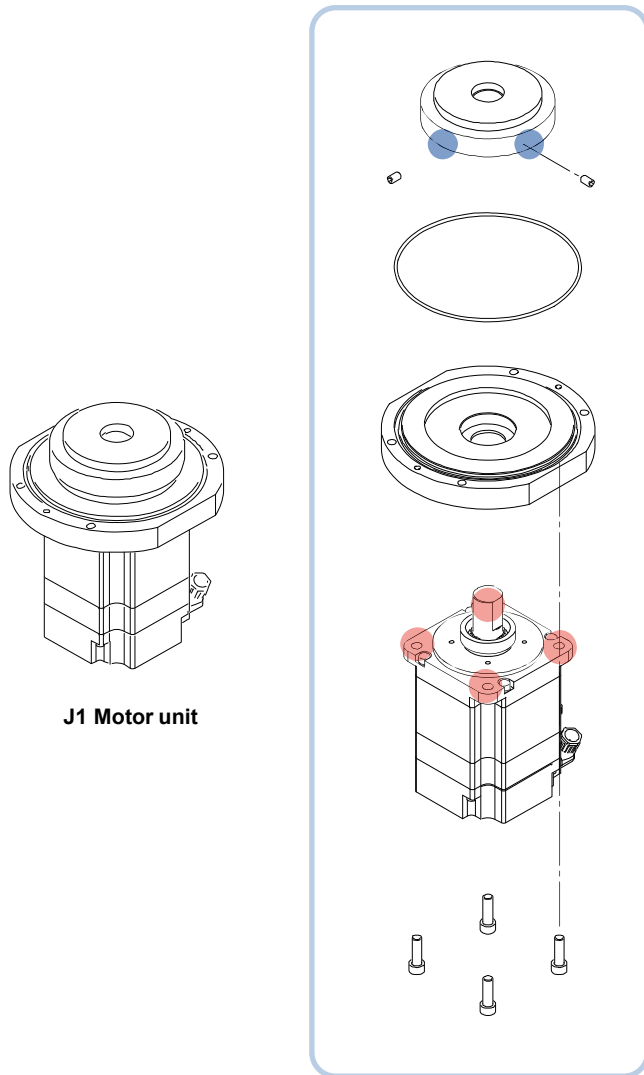

J1 Motor unit

**Step 3**  
**Waveform Generator**  
 S05: 2-M5x8  
 4.0 +/- 0.2 N·m

**Step 2**  
**O-ring**

**Step 1**  
**Motor Plate**  
 S01: 4-M6x20  
 13.0 +/- 0.6 N·m

**CAUTION**

Insert the O-ring firmly into the groove of the Motor Plate.

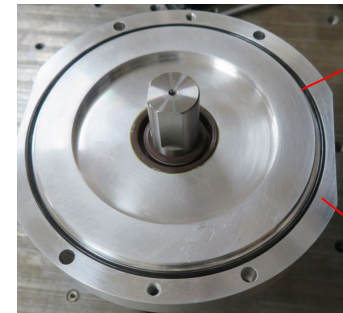

O-ring

Motor Plate

## 2.2.4 Assembling the J1 Motor Unit

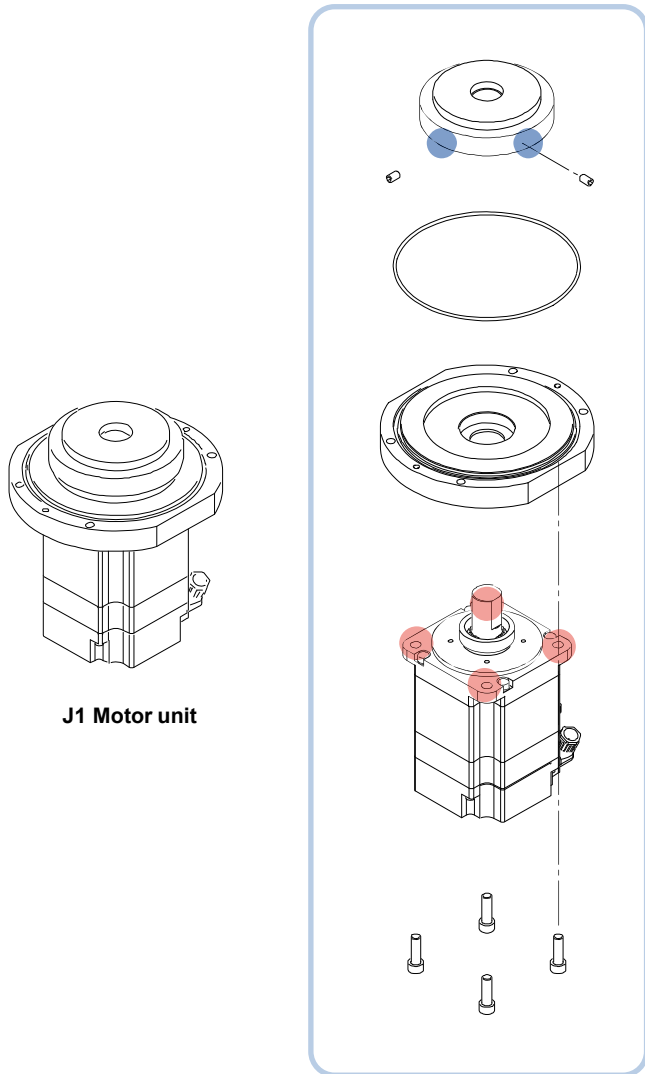

J1 Motor unit

**Step 3**  
**Waveform Generator**  
 S05: 2-M5x8  
 4.0 +/- 0.2 N·m

**Step 2**  
**O-ring**

**Step 1**  
**Motor Plate**  
 S01: 4-M6x20  
 13.0 +/- 0.6 N·m

**CAUTION**  
 Attach the Waveform Generator according to the orientation shown in the figure. If the Waveform Generator is attached in the wrong orientation, the performance of the Reduction Gear may not be sufficiently exhibited.  
 Secure the Waveform Generator with screws so that they are aligned with the D-Cuts of the motor shaft.

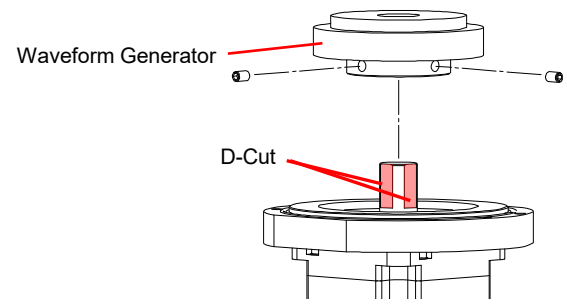

Secure the Waveform Generator at the position where the end face of the motor shaft is horizontal with the red marked section of the Waveform Generator.

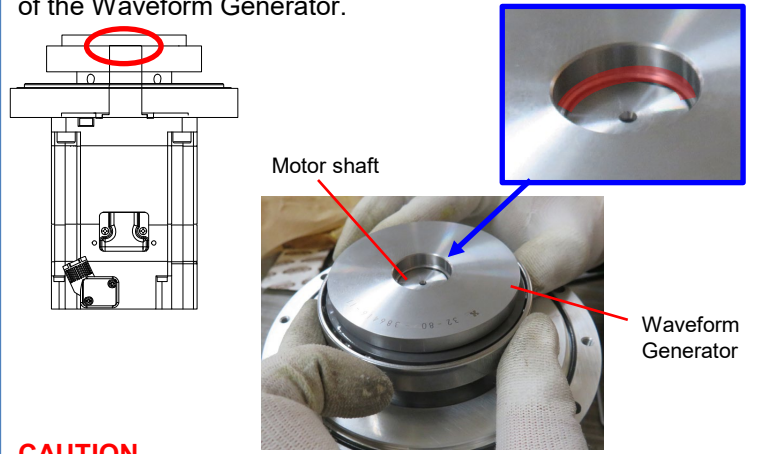

**CAUTION**  
 If the Waveform Generator is incorrectly attached, the assembly position of the Waveform Generator and Flexspline may deviate, and the performance of the Reduction Gear may not be sufficiently exhibited.

## 2.2.5 Removing the J1 Reduction Gear Unit

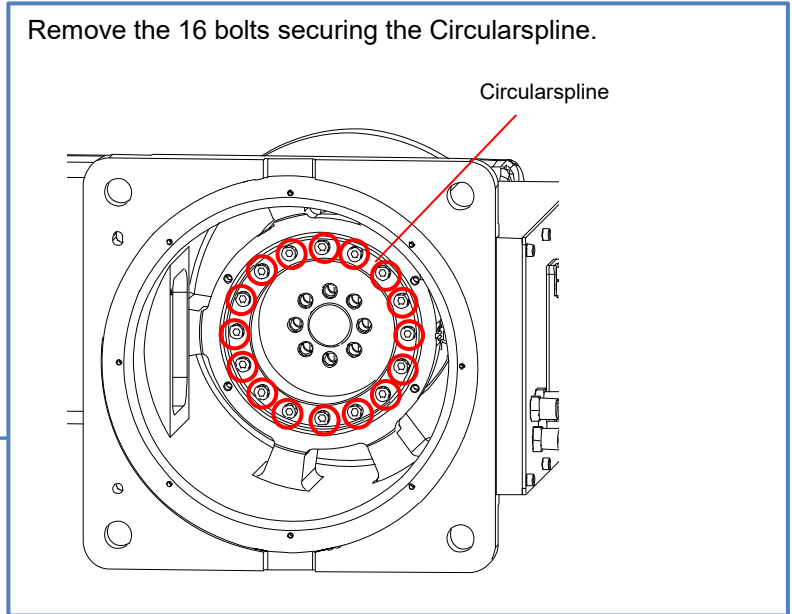
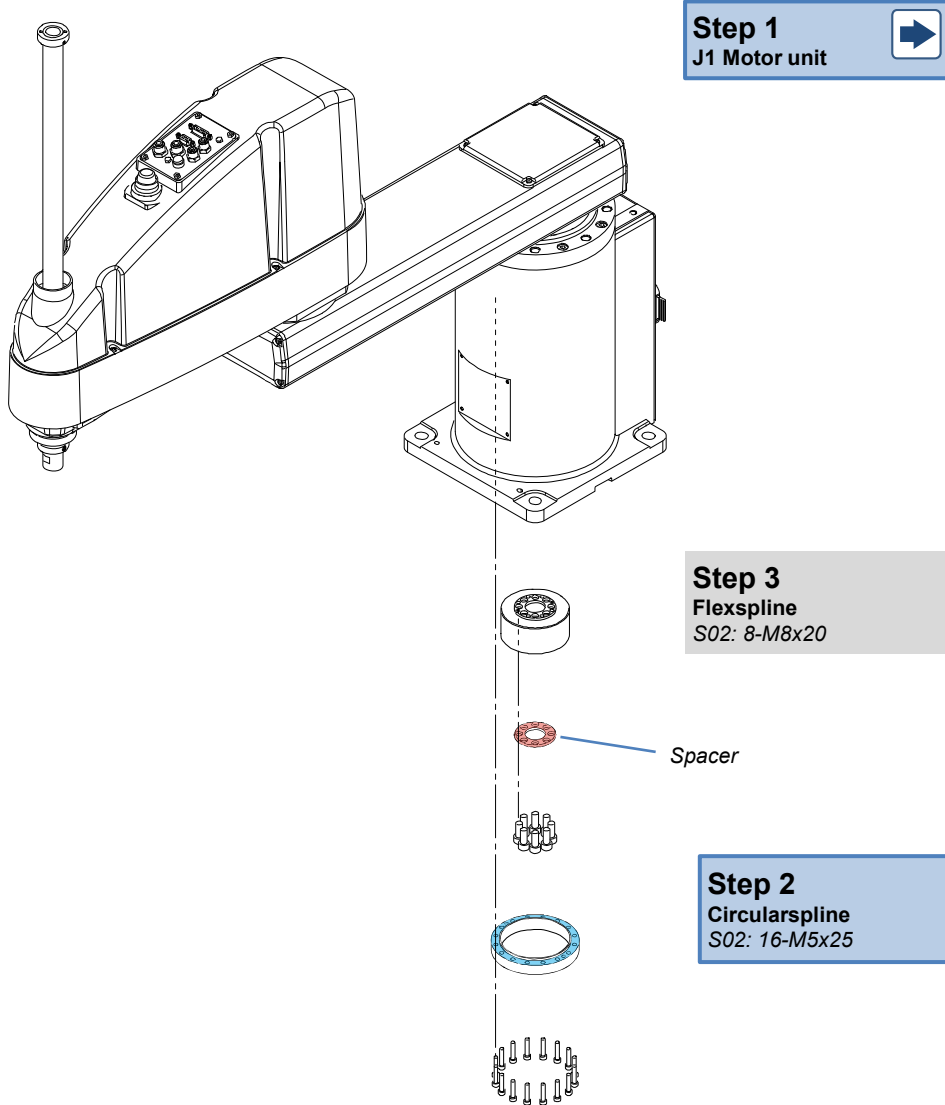

## 2.2.5 Removing the J1 Reduction Gear Unit

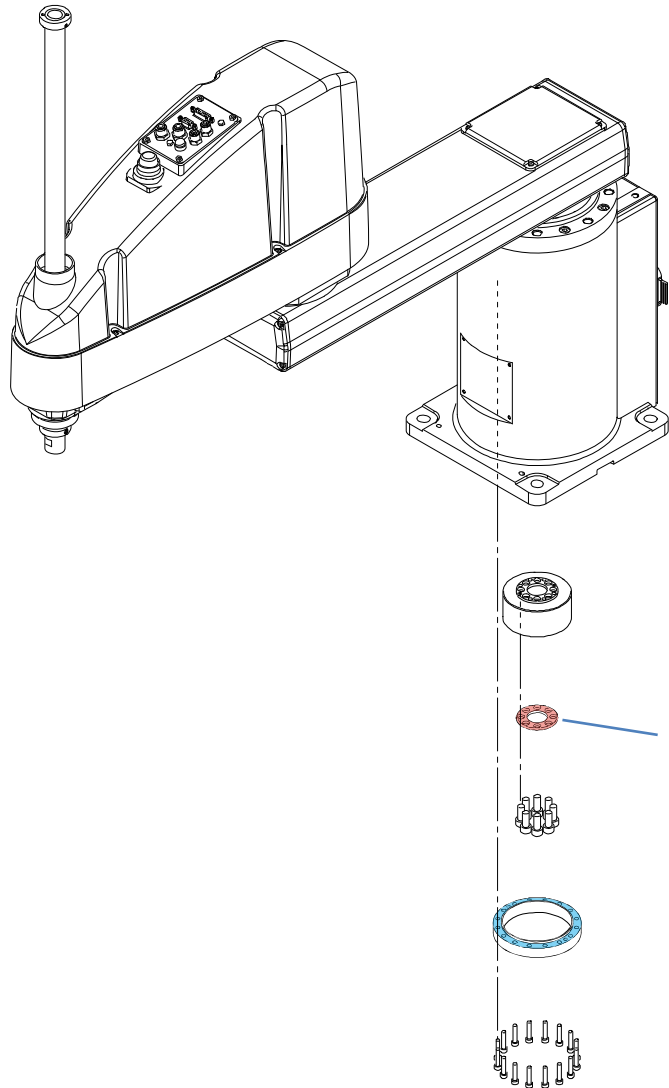

**Step 1**  
J1 Motor unit

**Step 3**  
Flexspline  
S02: 8-M8x20

Spacer

**Step 2**  
Circularspline  
S02: 16-M5x25

1. Remove the eight bolts and Spacer securing the Flexspline.

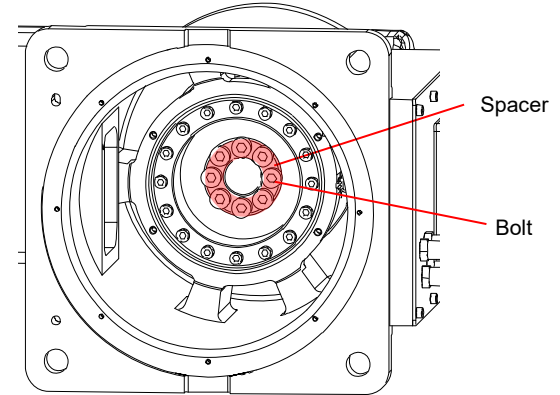

2. Set the M5 forcing tap upright at the positions shown in the figure, and remove the Flexspline and Circularspline together.

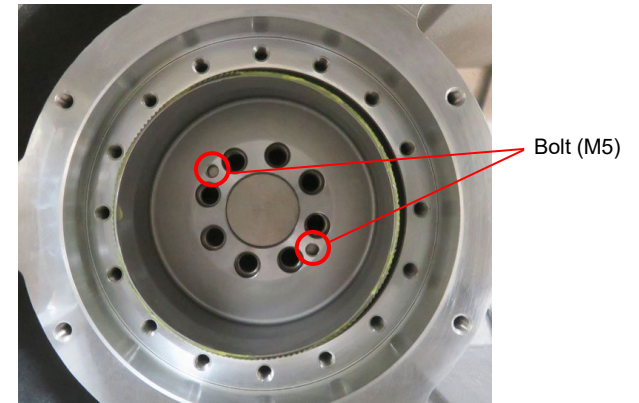

## 2.2.6 Installing the J1 Reduction Gear Unit

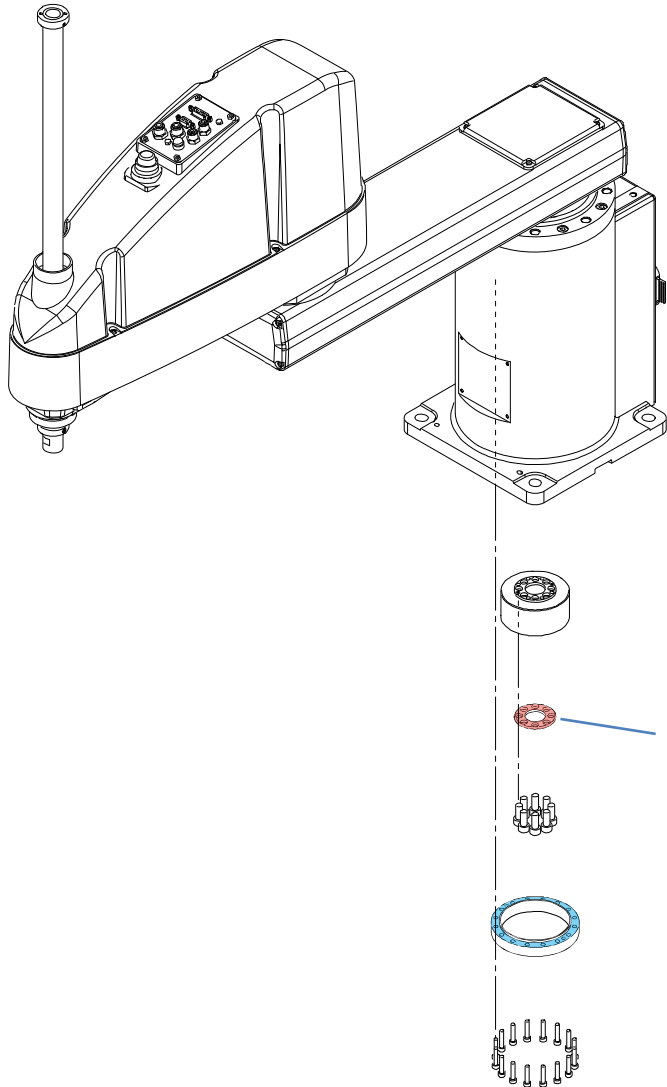

**Step 3**  
J1 Motor unit

**Step 2**  
Flexspline  
S02: 8-M8x20  
44.0 +/- 2.2 N.m

Spacer

**Step 1**  
Circularspline  
S02: 16-M5x25  
10.0 +/- 0.5 N.m

**CAUTION**

Before performing maintenance, make sure that the serial numbers Reduction Gear Unit match (Waveform Generator, Circular Spline/Flexspline). Using parts with different serial numbers may result in vibrations, abnormal noise, or other issues that may affect the accuracy of the robot.

**POINT**

Perform the work after wiping off old grease or anti-rust oil.

**POINT**



**SK-1A: Small amount (refer to the figure below)**

Apply SK-1A grease to the extent that the teeth of the Circularspline and Flexspline are hidden before installing them. This will protect the teeth surfaces when assembling the parts.

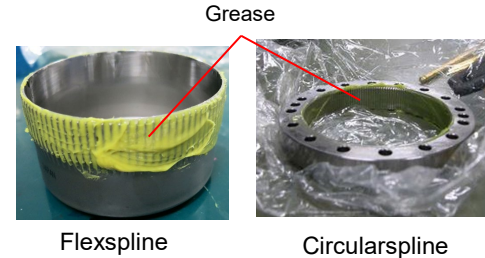

Flexspline

Circularspline

## 2.2.6 Installing the J1 Reduction Gear Unit

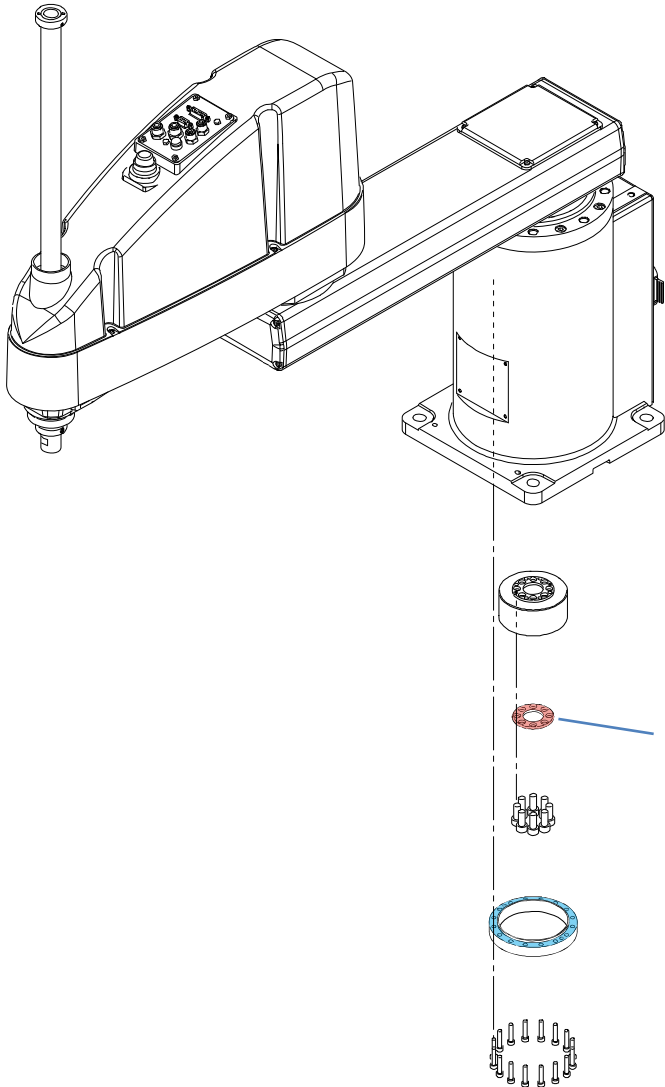

**Step 3**  
J1 Motor unit

**Step 2**  
Flexspline  
S02: 8-M8x20  
44.0 +/- 2.2 N.m

Spacer

**Step 1**  
Circularspline  
S02: 16-M5x25  
10.0 +/- 0.5 N.m

**Installing the Circularspline**

Install the Circularspline with its convex surface towards the base side.

## 2.2.6 Installing the J1 Reduction Gear Unit

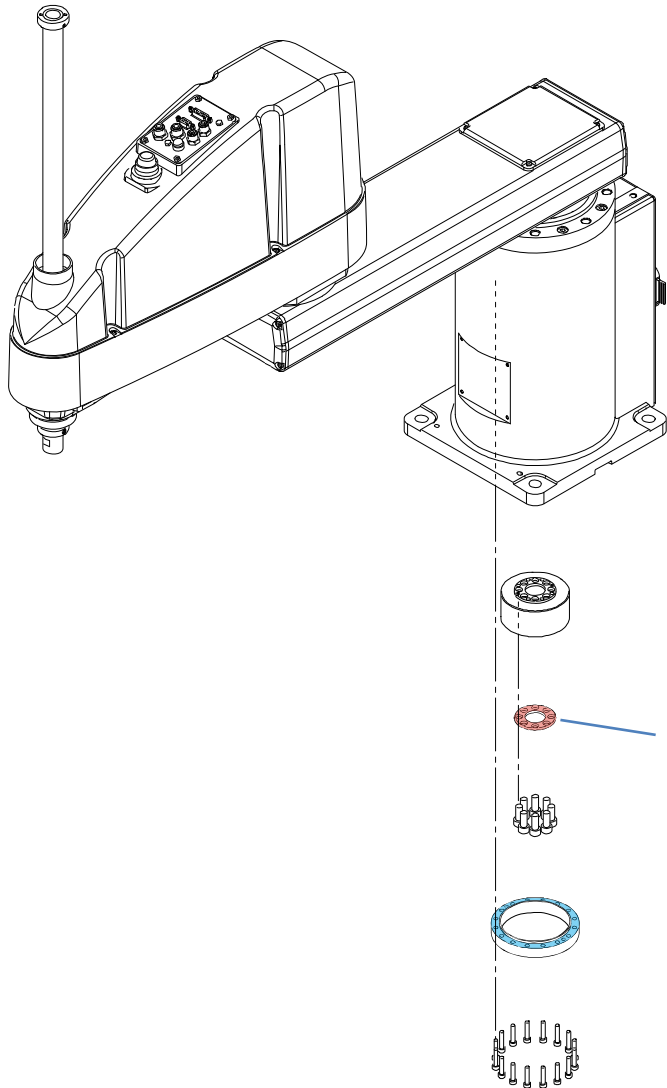

**Step 3**  
J1 Motor unit

**Step 2**  
Flexspline  
S02: 8-M8x20  
44.0 +/- 2.2 N.m

**Step 1**  
Circularspline  
S02: 16-M5x25  
10.0 +/- 0.5 N.m

### Installing the Flexspline

As shown in the figure, install two bolts into the tapped holes of the Flexspline.

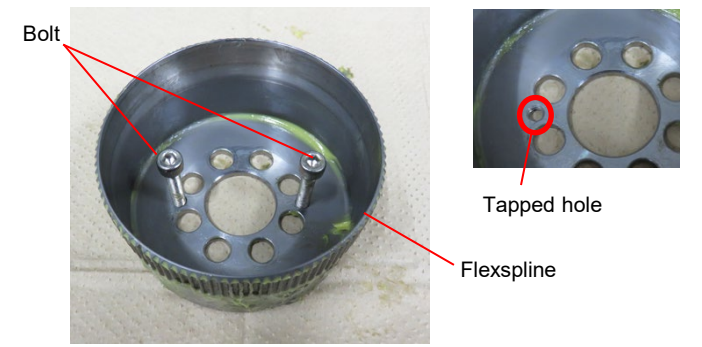

Using the bolts as a support, fit the Flexspline into the Circularspline.  
After placing the Flexspline, remove the two bolts.

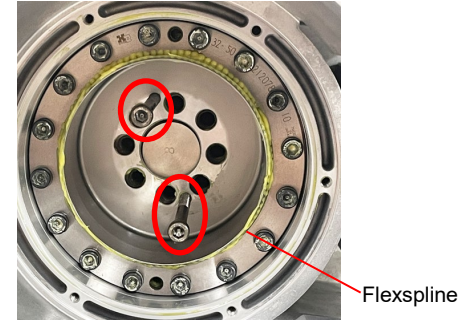

**CAUTION**  
Make sure that the teeth of the Circularspline and Flexspline are properly engaged with each other.

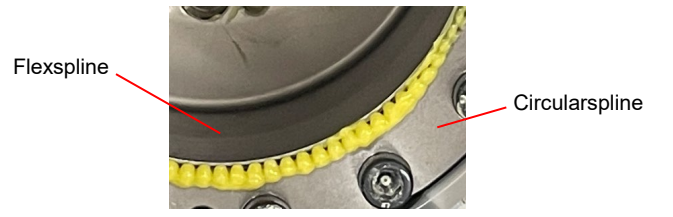

## 2.2.6 Installing the J1 Reduction Gear Unit

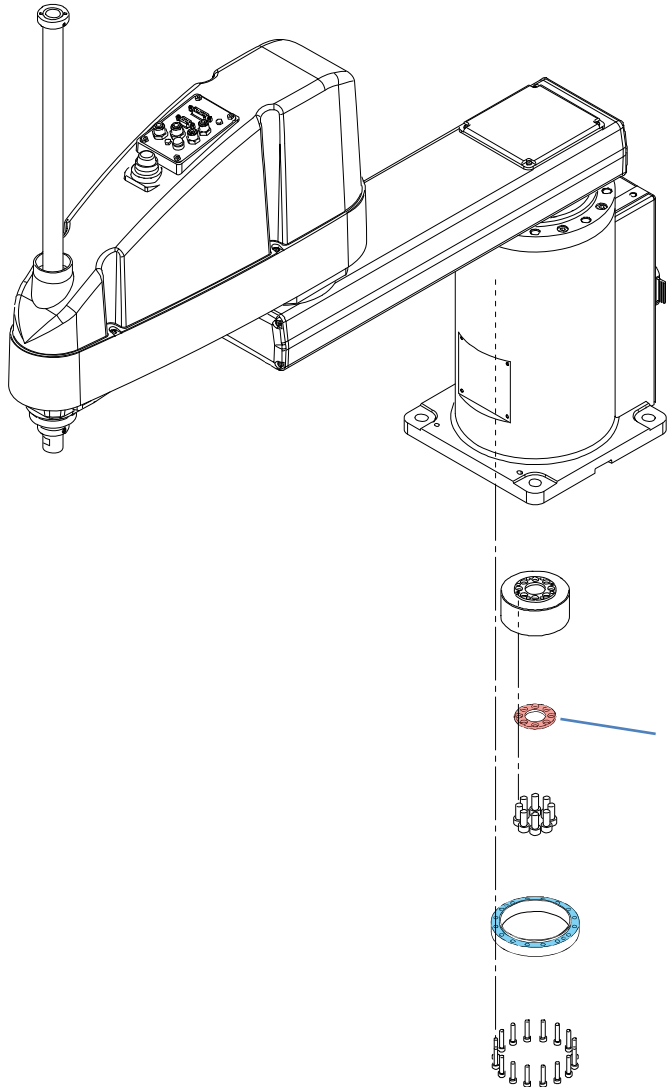

**Step 3**  
J1 Motor unit

**Step 2**  
Flexspline  
S02: 8-M8x20  
44.0 +/- 2.2 N.m

Spacer

**Step 1**  
Circularspline  
S02: 16-M5x25  
10.0 +/- 0.5 N.m

**Installing the Flexspline**  
Install the Flexspline with its tapped holes aligned with the air holes of the Spacer.

Tapped hole

Flexspline

Air hole

Spacer



## 2.2.6 Installing the J1 Reduction Gear Unit

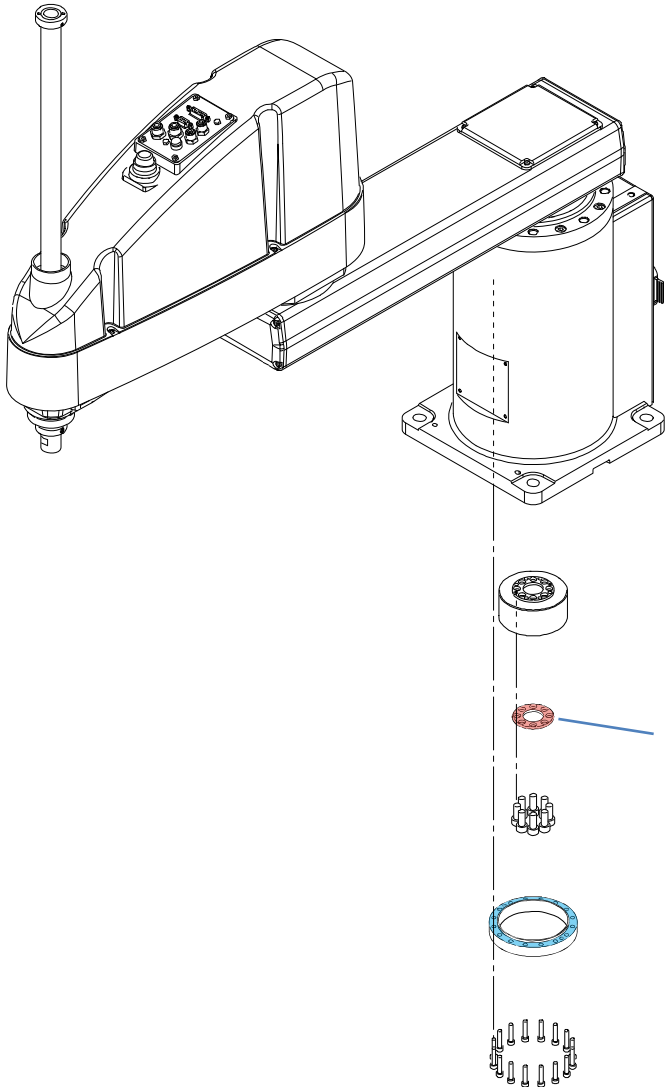

**Step 3**  
J1 Motor unit



**POINT**

After installing the J1 Motor unit, return the Manipulator to its installed state and fix in place.

**Step 2**  
Flexspline  
S02: 8-M8x20  
44.0 +/- 2.2 N.m

Spacer

**Step 1**  
Circularspline  
S02: 16-M5x25  
10.0 +/- 0.5 N.m

Apply grease to the inside of the Flexspline.

 **SK-1A: 43 g**

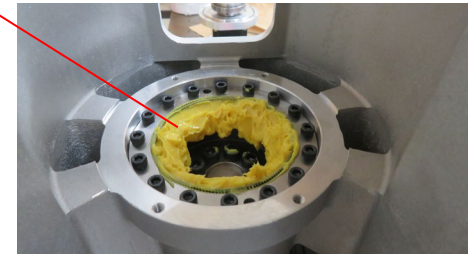
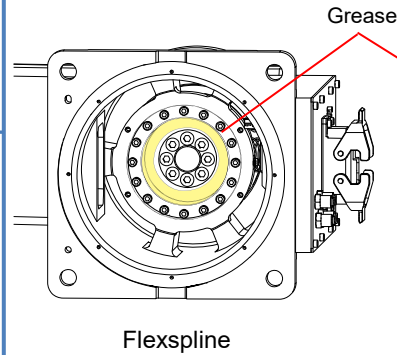

**CAUTION**

After assembling the motor unit, perform calibration of Joint #1.  
[3.1 Calibration](#)

## 2.3 Joint #2

### 2.3.1 Removing the J2 Motor Unit

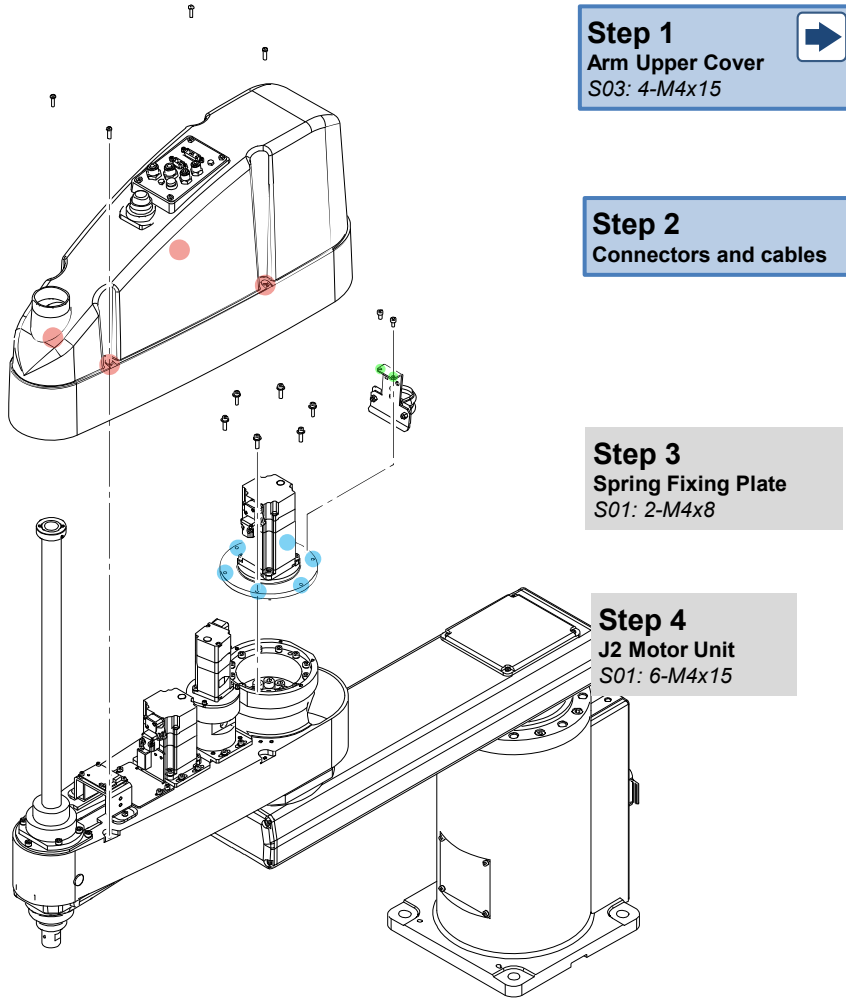

#### Disconnecting the Connectors and Cables

Disconnect the connectors, and remove the wire tie and Silicone Sheet shown in the figure.

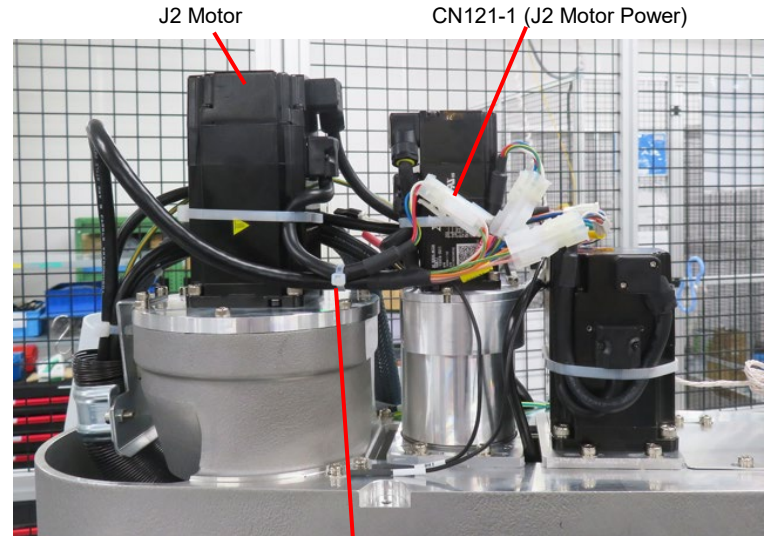

CN321-1 (J2 Motor Signal)  
Silicone Sheet  
Wire tie (AB150)

CN400-2 (Brake Branch)  
CN402-1 (Brake Branch)

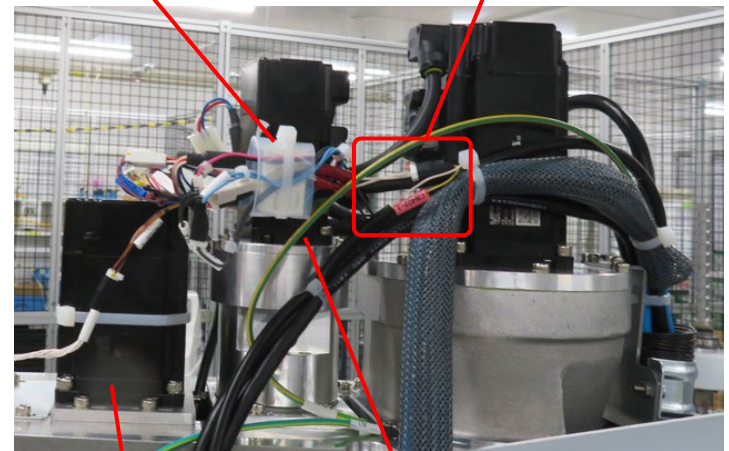

### 2.3.1 Removing the J2 Motor Unit

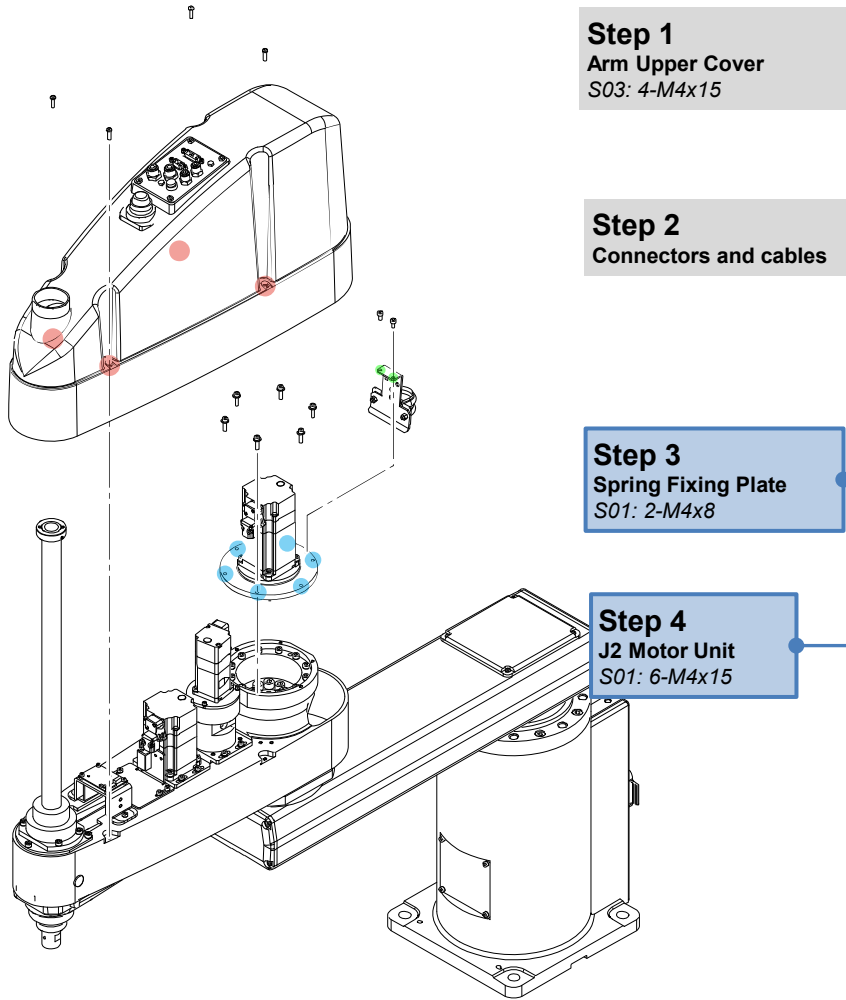

Remove the screws shown in the figure, and remove the Spring Fixing Plate from the Motor Plate.

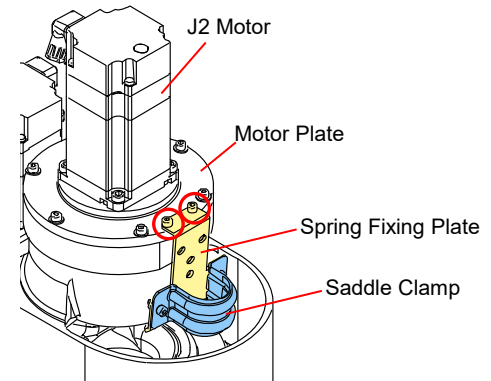

#### Removing the J2 Motor Unit

**POINT**

- When removing the J2 Motor unit, remove it straight upwards.
- When it is difficult to remove the motor, remove the motor while gently moving Arm2 back and forth.

**CAUTION**

Grease may drop from the Waveform Generator. Take care that it does not adhere on to the surrounding parts.

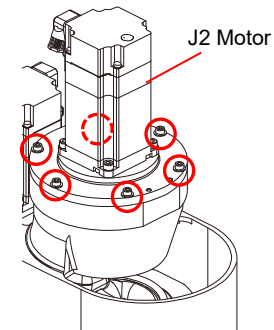

### 2.3.2 Installing the J2 Motor Unit

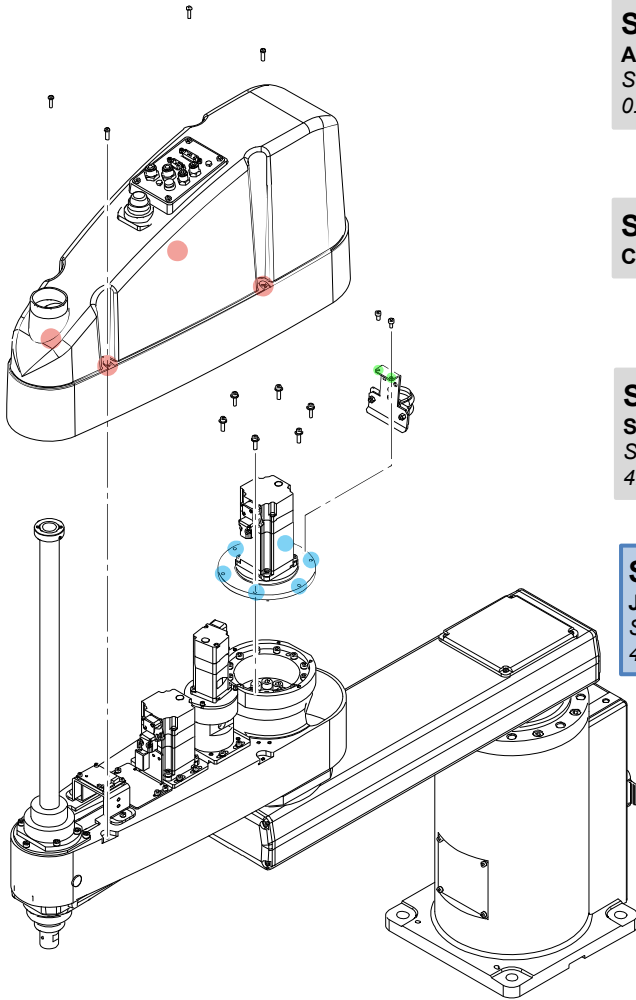

**Step 4**  
**Arm Upper Cover**  
 S03: 4-M4x15  
 0.45 +/- 0.1 N·m

**Step 3**  
**Connectors and cables**

**Step 2**  
**Spring Fixing Plate**  
 S01: 2-M4x8  
 4.0 +/- 0.2 N·m

**Step 1**  
**J2 Motor unit**  
 S01: 6-M4x15  
 4.0 +/- 0.2 N·m

**CAUTION**

- Install the motor unit after rotating the Waveform Generator so that the longside of the Waveform Generator matches the Flexspline.
- Install the motor unit so that its connector faces the ball screw spline.

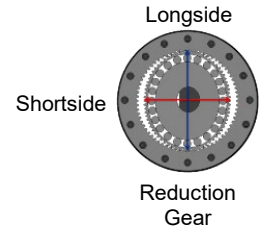

J2 Motor unit

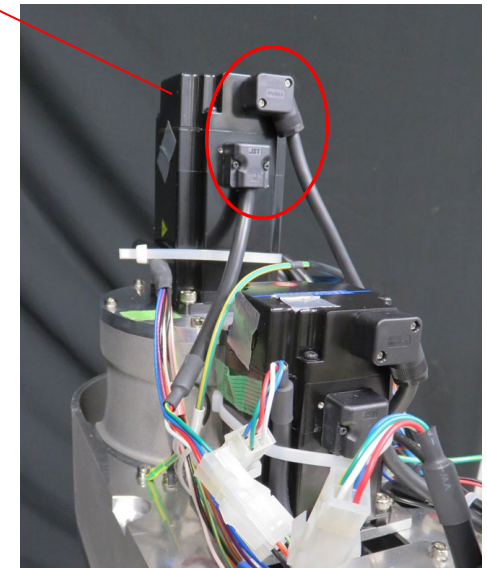

**POINT**

When it is difficult for the motor unit to be placed, push in the motor unit while gently moving Arm2.

### 2.3.2 Installing the J2 Motor Unit

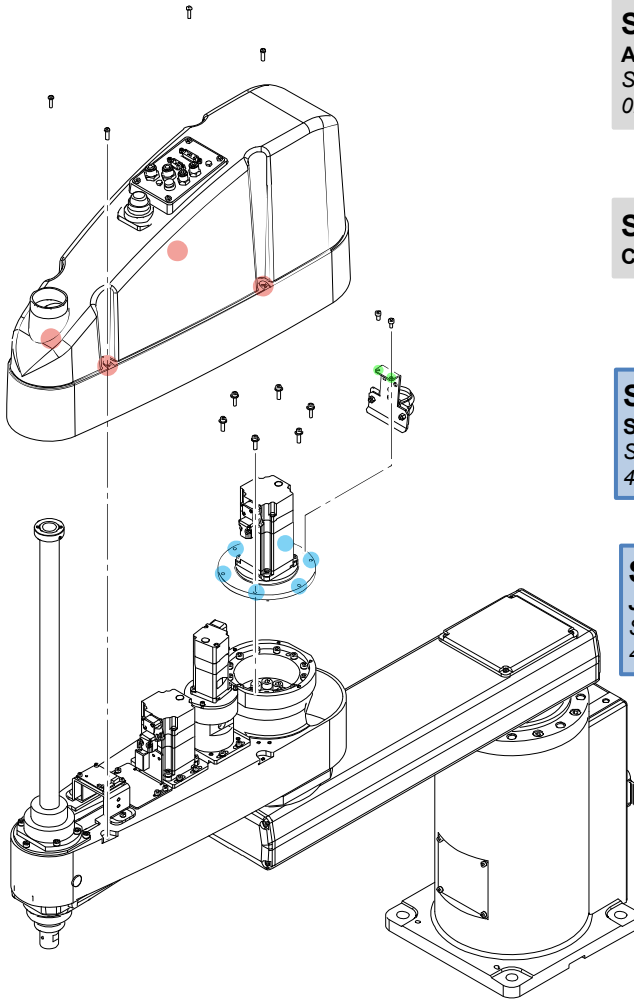

**Step 4**

**Arm Upper Cover**  
 S03: 4-M4x15  
 0.45 +/- 0.1 N·m

**Step 3**

**Connectors and cables**

**Step 2**

**Spring Fixing Plate**  
 S01: 2-M4x8  
 4.0 +/- 0.2 N·m

**Step 1**

**J2 Motor unit**  
 S01: 6-M4x15  
 4.0 +/- 0.2 N·m

Secure Spring Fixing Plate to the Motor Plate by securing the screws shown in the figure.

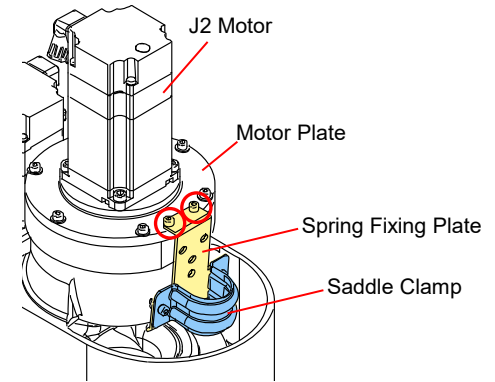

**CAUTION**

To reduce vibrations and noise during operation of the Manipulator, turn the arm after installing the motor unit, and perform centering. (Turn back and forth three times by approximately 90° each time.)

After centering is completed, tighten the bolts on the motor unit.

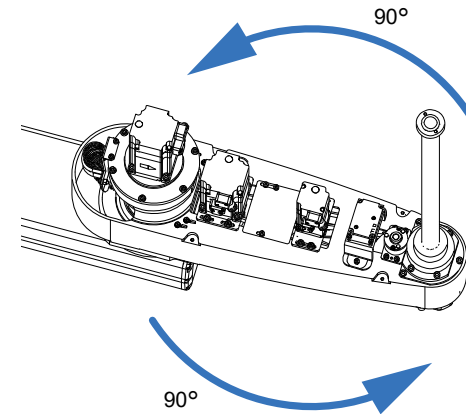



### 2.3.2 Installing the J2 Motor Unit

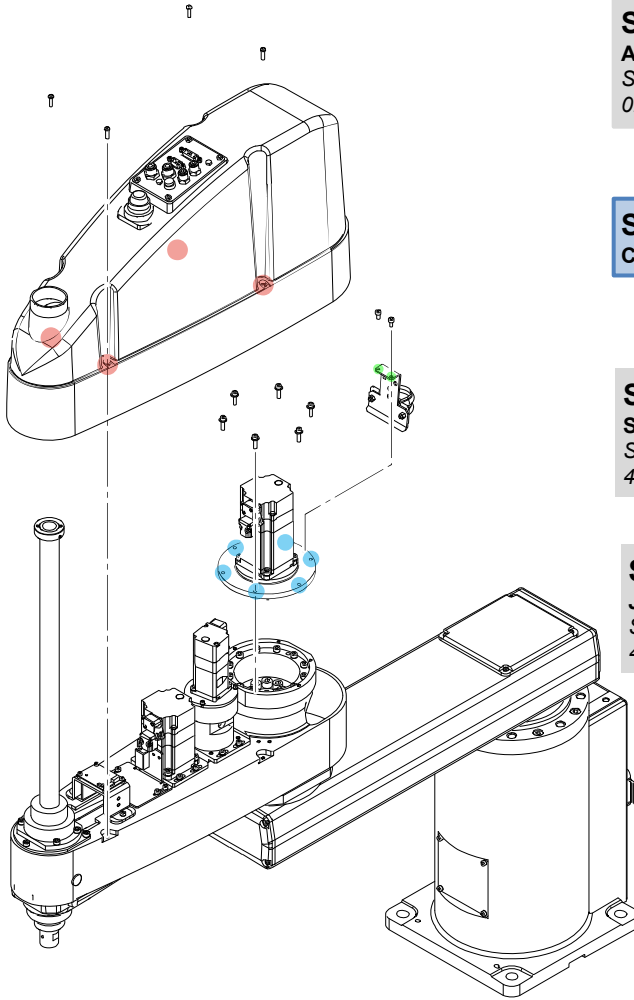

**Step 4**  
**Arm Upper Cover**  
 S03: 4-M4x15  
 0.45 +/- 0.1 N·m

**Step 3**  
**Connectors and cables**

**Step 2**  
**Spring Fixing Plate**  
 S01: 2-M4x8  
 4.0 +/- 0.2 N·m

**Step 1**  
**J2 Motor unit**  
 S01: 6-M4x15  
 4.0 +/- 0.2 N·m

**Installing the Connector and Cables**  
 Connect the connector shown in the figure, and secure with a wire tie.

**CAUTION**  
 Take care not to apply a load to the cables, for example, by bending the cables with excessive force.

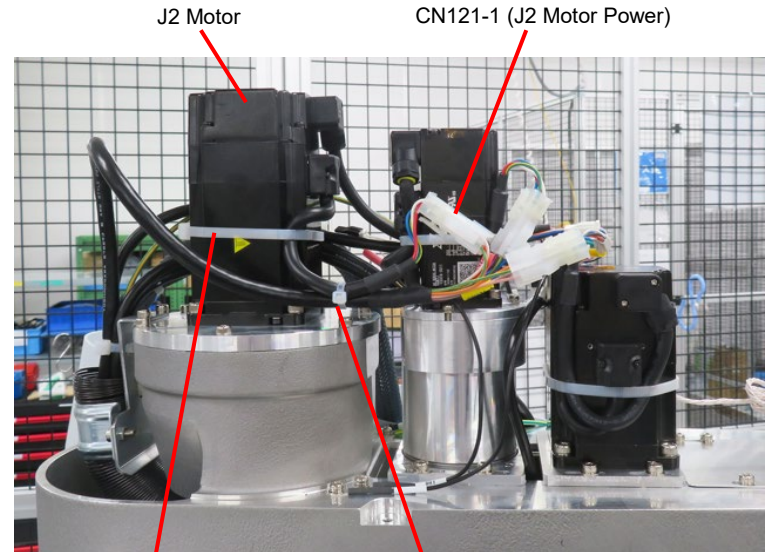

Secure the motor cable to the J2 Motor with wire tie (AB150).

Wire tie (AB150)

### 2.3.2 Installing the J2 Motor Unit

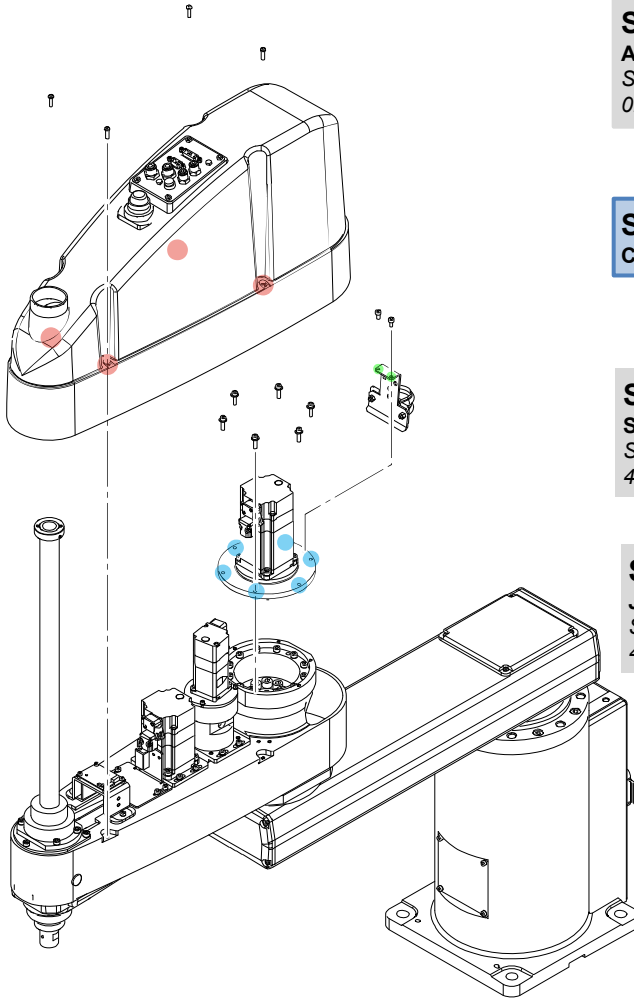

#### Step 4

**Arm Upper Cover**  
 S03: 4-M4x15  
 0.45 +/- 0.1 N·m

#### Step 3

**Connectors and cables**

#### Step 2

**Spring Fixing Plate**  
 S01: 2-M4x8  
 4.0 +/- 0.2 N·m

#### Step 1

**J2 Motor unit**  
 S01: 6-M4x15  
 4.0 +/- 0.2 N·m

#### Installing the Connector and Cables

Wrap CN321-1 with the Silicone Sheet together with the other connectors and cables, and secure them with a wire tie (AB150).

#### CAUTION

Take care not to apply a load to the cables, for example, by bending the cables with excessive force.

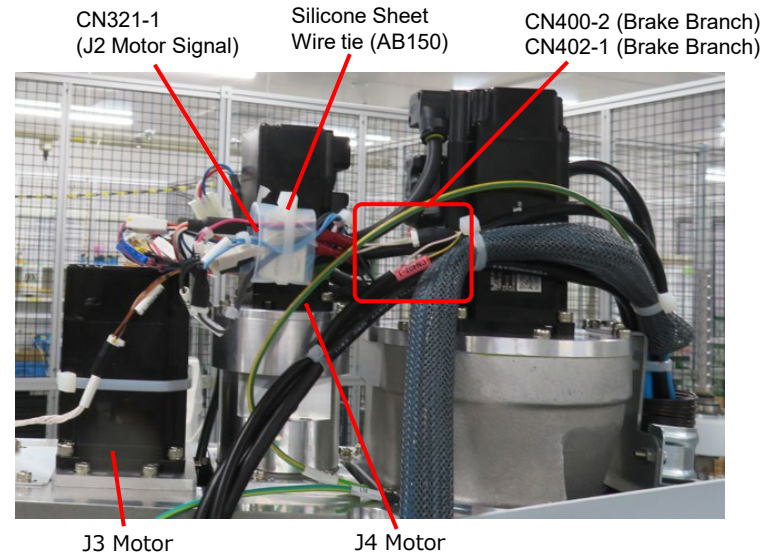

### 2.3.2 Installing the J2 Motor Unit

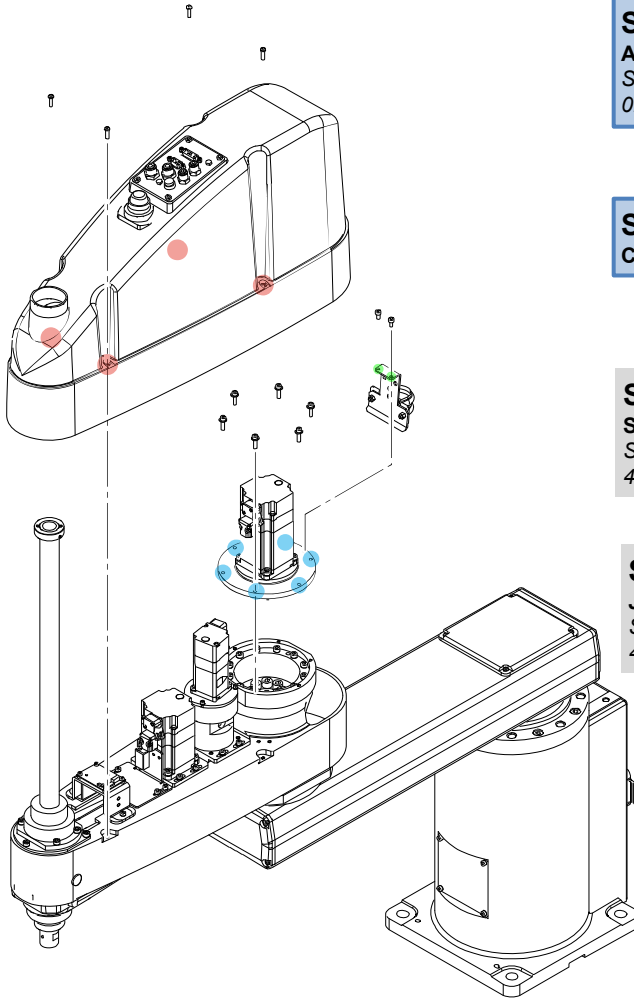

**Step 4**

Arm Upper Cover  
 S03: 4-M4x15  
 0.45 +/- 0.1 N·m



**Step 3**

Connectors and cables

**Step 2**

Spring Fixing Plate  
 S01: 2-M4x8  
 4.0 +/- 0.2 N·m

**Step 1**

J2 Motor unit  
 S01: 6-M4x15  
 4.0 +/- 0.2 N·m

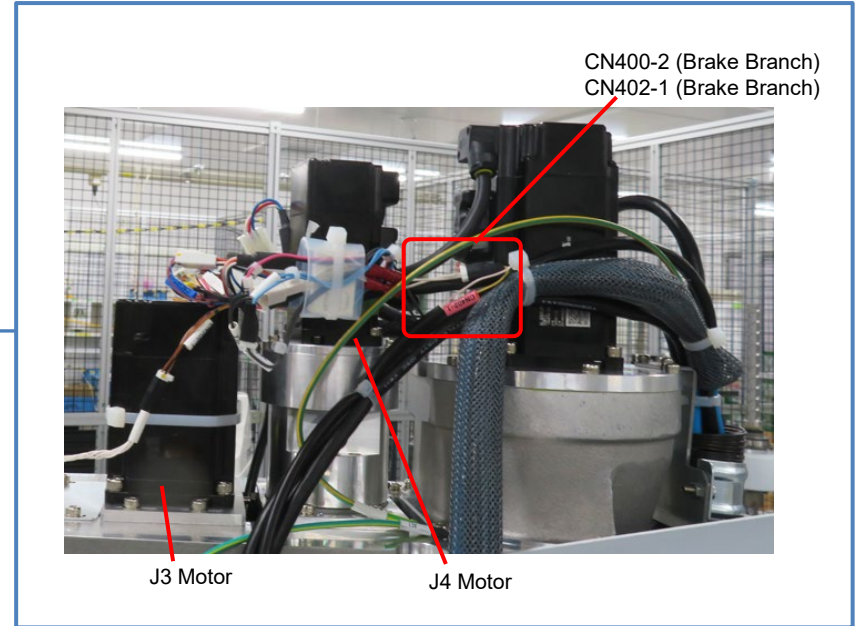

**CAUTION**  
 After assembling the motor unit, perform calibration of Joint #2.  
[3.1 Calibration](#)



### 2.3.3 Disassembling the J2 Motor Unit

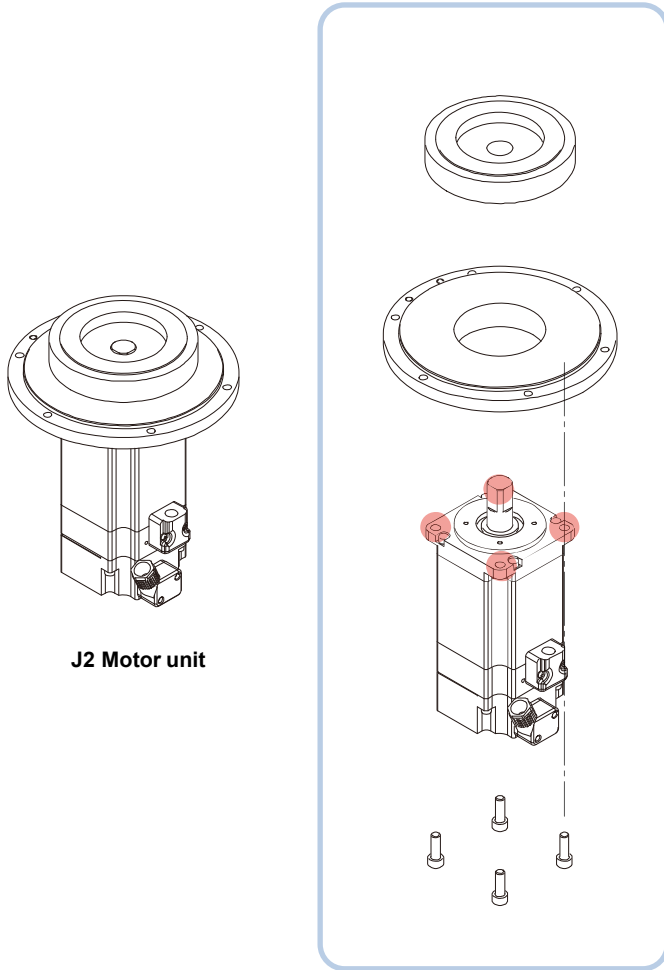

J2 Motor unit

**Step 1**  
Waveform Generator  
S05: 2-M5x8

**Step 2**  
Motor Plate  
S01: 4-M5x15

**CAUTION**

Before performing maintenance, wipe off the excess grease adhering on to the Joint #2 Motor unit.

**POINT**

Wipe off the old grease before removing the Waveform Generator from the motor unit.

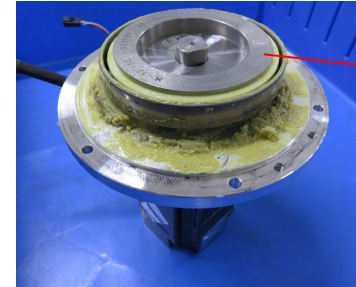

Waveform Generator

### 2.3.4 Assembling the J2 Motor Unit

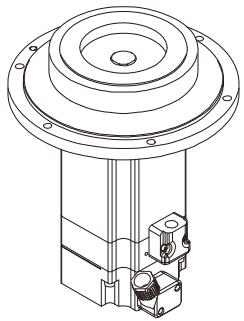

J2 Motor unit

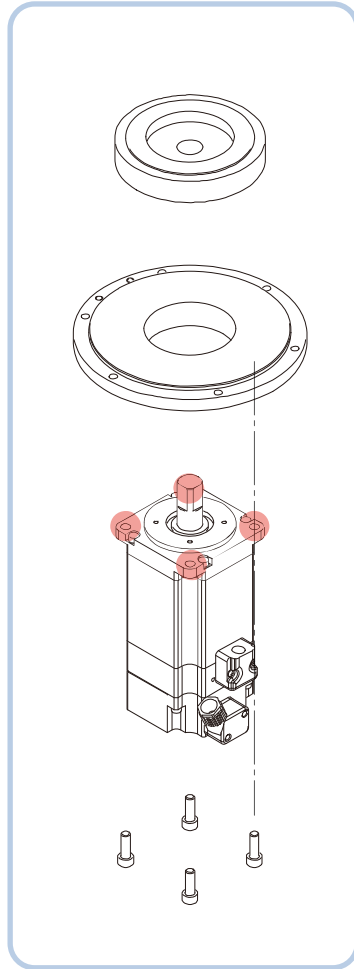

**Step 2**  
**Waveform Generator**  
 S05: 2-M5x8  
 4.0 +/- 0.2 N.m

**Step 1**  
**Motor Plate**  
 S01: 4-M5x15  
 8.0 +/- 0.4 N.m

**CAUTION**

Attach the Joint #2 Motor and the Motor Plate according to the orientation shown in the figure. If the installation orientation is incorrect, the cable might not reach the connectors after the motor is fixed in the arm.

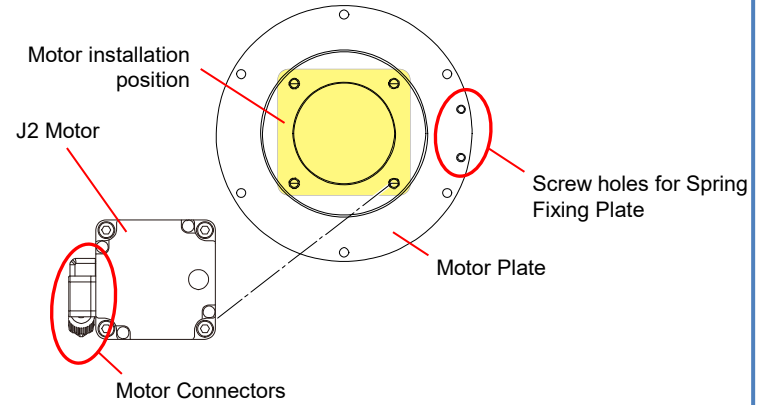

After installing the Motor Plate, apply grease to the location shown in the figure.

 **SK-1A: 28 g**

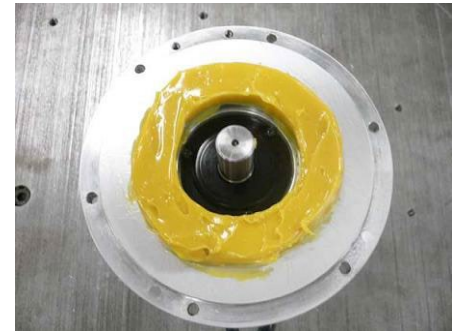

### 2.3.4 Assembling the J2 Motor Unit

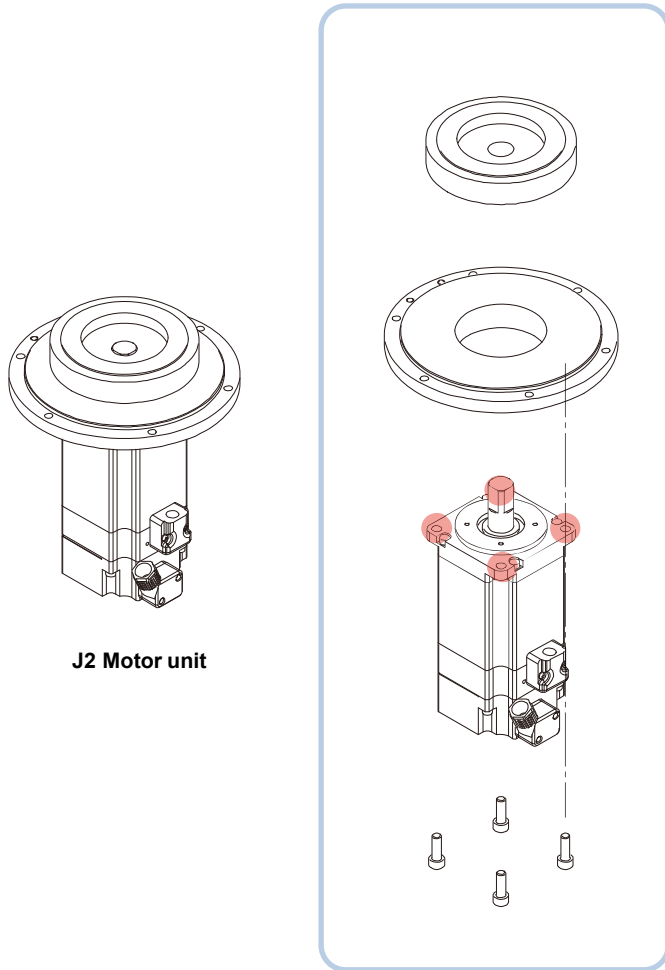

J2 Motor unit

**Step 2**  
**Waveform Generator**  
 S05: 2-M5x8  
 4.0 +/- 0.2 N.m

**Step 1**  
**Motor Plate**  
 S01: 4-M5x15  
 8.0 +/- 0.4 N.m

Secure the Waveform Generator to the motor shaft by using the Gap Adjustment JIG.

**CAUTION**

- The Gap Adjustment Jig can be used for both GX10 and GX20.  
 Be sure to use the jig for the GX20 in this Step.
- If the Waveform Generator is incorrectly attached, the assembly position of the Waveform Generator and Flexspline may deviate, and the performance of the Reduction Gear may not be sufficiently exhibited.

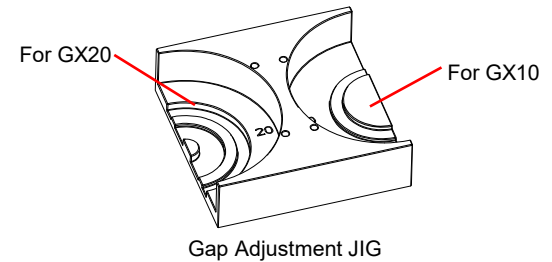

1. Set the Waveform Generator on the Gap Adjustment JIG in the orientation shown in the figure.

**POINT**

Set the Waveform Generator so that the screw holes face the outside of the jig. Work can be performed more easily by securing the Waveform Generator on the motor shaft.

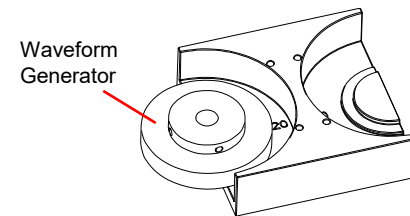

### 2.3.4 Assembling the J2 Motor Unit

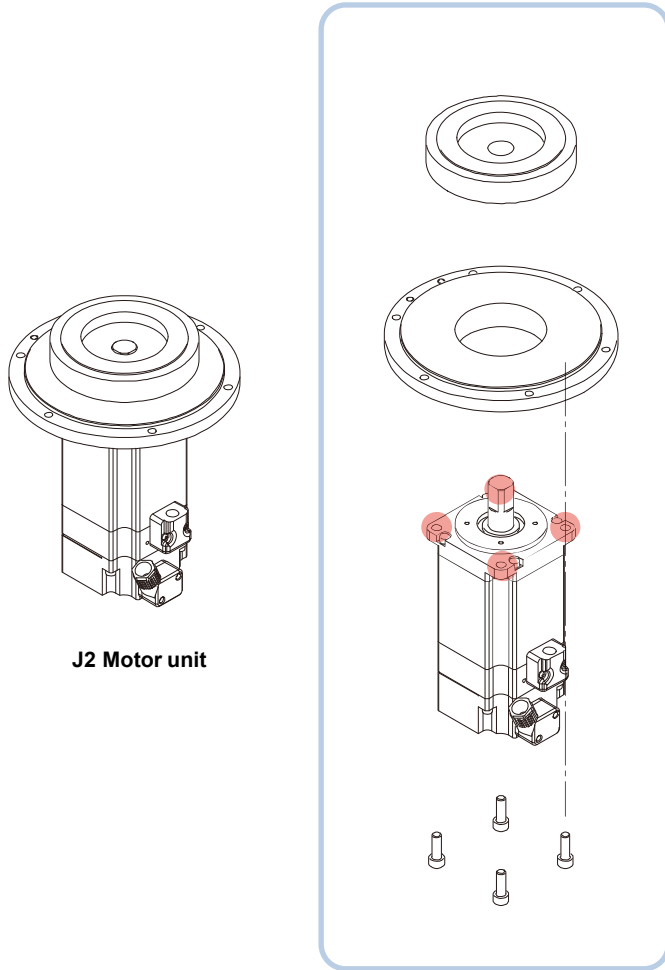

J2 Motor unit

**Step 2**  
**Waveform Generator**  
 S05: 2-M5x8  
 4.0 +/- 0.2 N.m

**Step 1**  
**Motor Plate**  
 S01: 4-M5x15  
 8.0 +/- 0.4 N.m

2. Secure the J2 Motor Plate on the Gap Adjustment JIG by using the two screws for securing the Motor Plate to the arm.
3. Secure the Waveform Generator to the motor shaft so that the D-Cut of the motor shaft is aligned with the screw holes of the Waveform Generator.

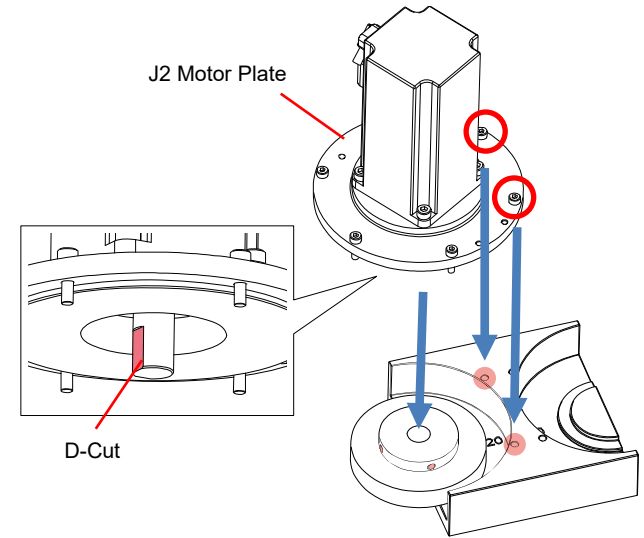

4. Remove the Motor Plate screws, and remove the J2 Motor Unit from the Gap Adjustment JIG.

### 2.3.5 Removing the J2 Reduction Gear Unit

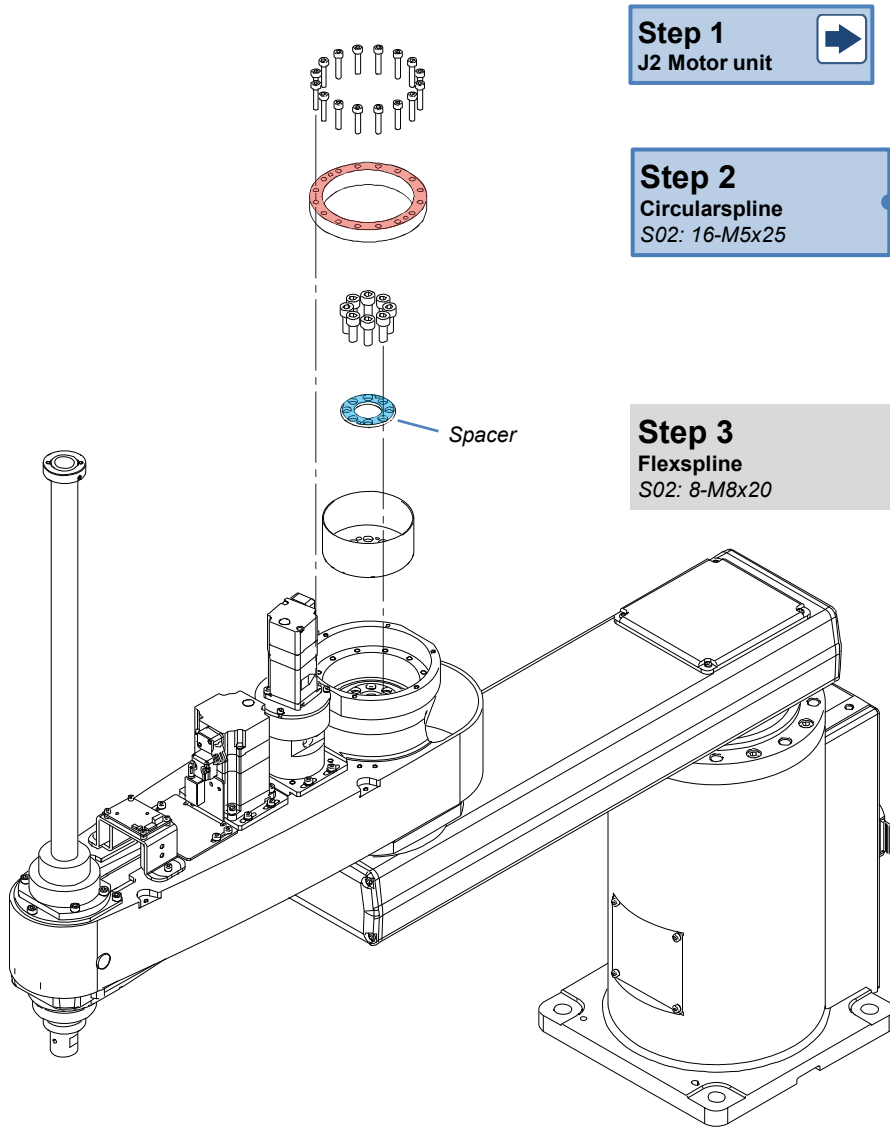

Remove the 16 bolts securing the Circularspline.

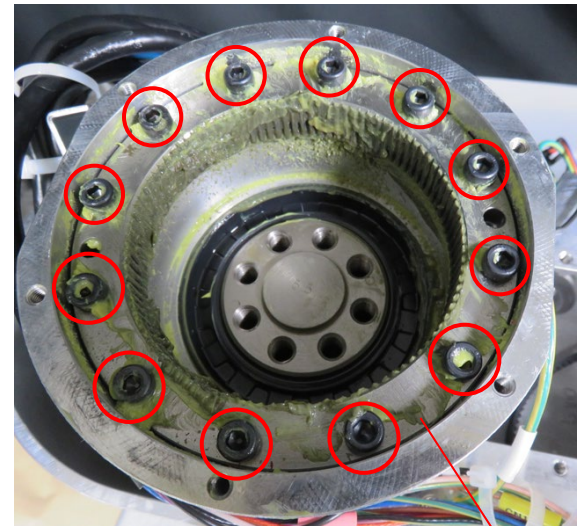

Circularspline

### 2.3.5 Removing the J2 Reduction Gear Unit

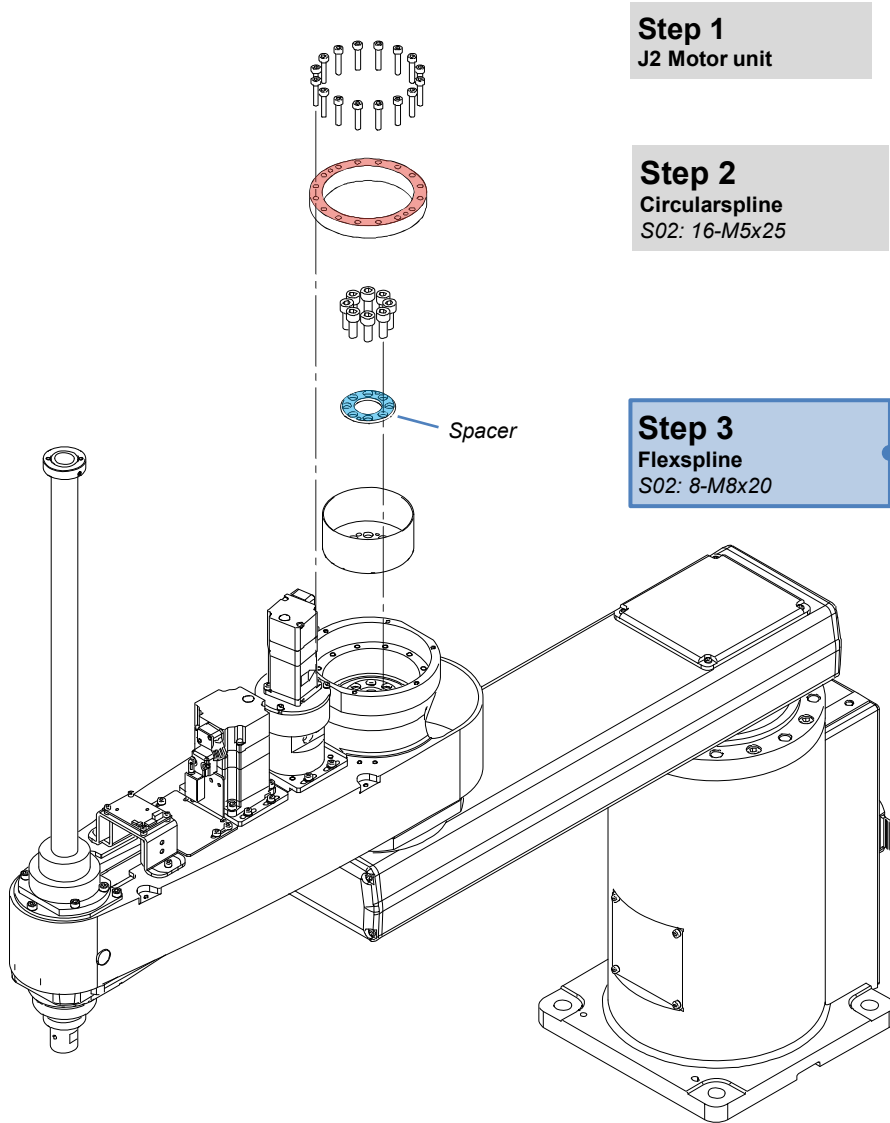

1. Remove the eight bolts and Spacer securing the Flexspline.

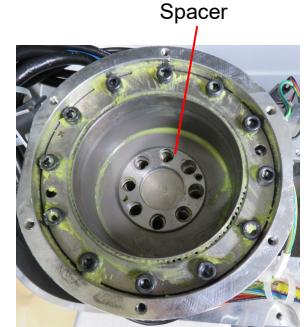
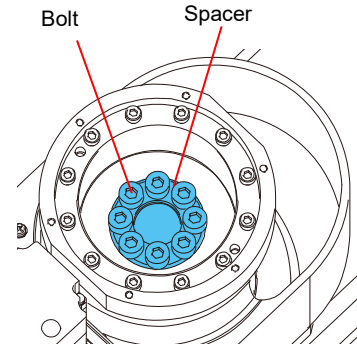

2. After removing the Spacer, set the M5 forcing tap upright at the positions shown in the figure below.

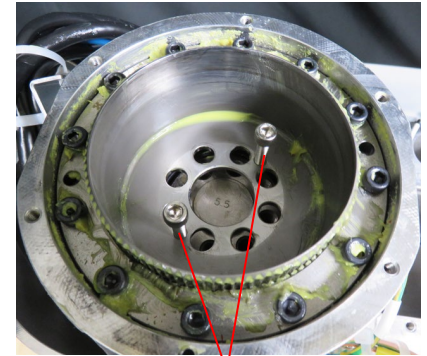
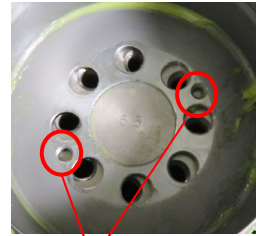

3. Holding the M5 forcing tap, and remove the Flexspline and Circularspline together.



### 2.3.6 Installing the J2 Reduction Gear Unit

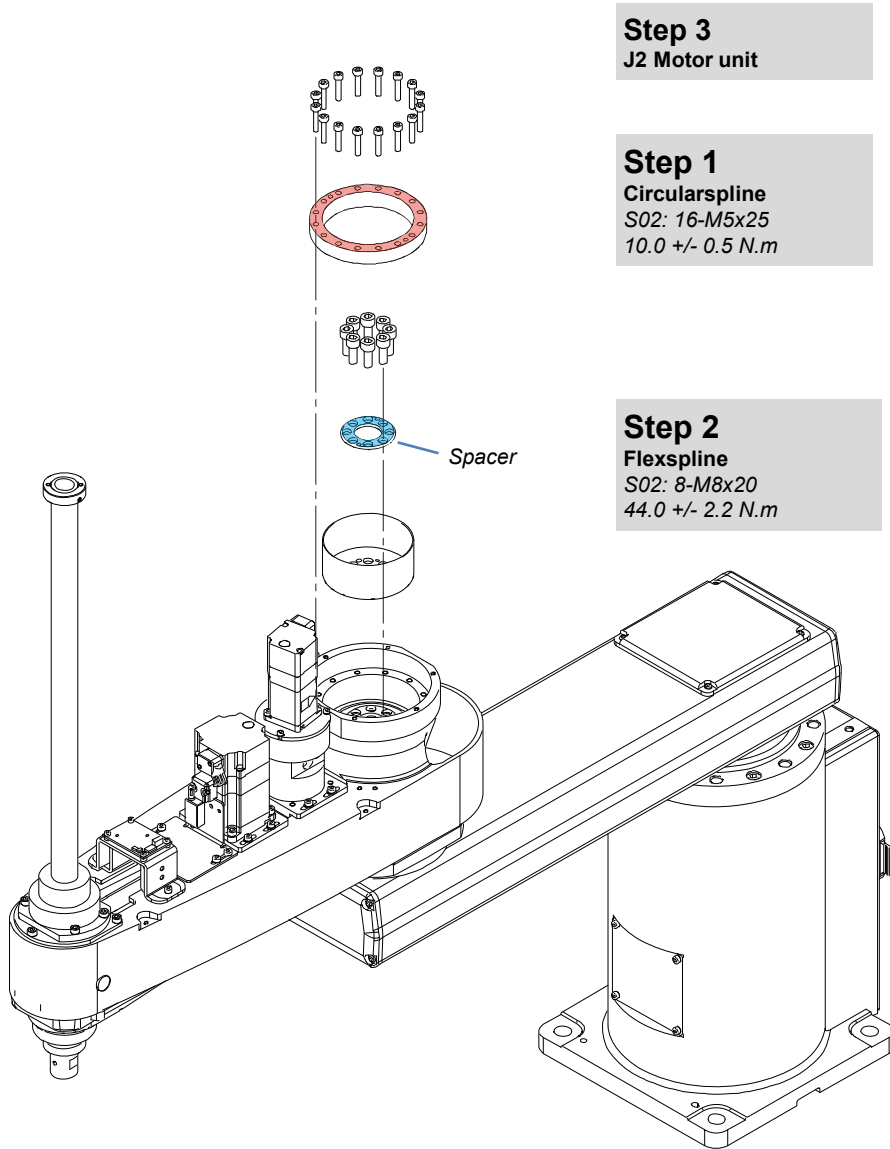

#### CAUTION

Before performing maintenance, make sure that the serial numbers of the Waveform Generator, Flexspline, and Circular Spline match. Using parts with different serial numbers may result in vibrations, abnormal noise, or other issues that may affect the accuracy of the robot.

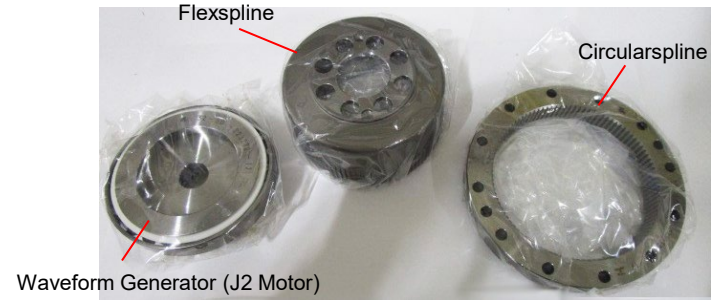

#### POINT

Perform the work after wiping off old grease or anti-rust oil.

#### POINT

 **SK-1A: Small amount (refer to the figure below)**

Apply SK-1A grease to the extent that the teeth of the Circularspline and Flexspline are hidden before installing them. This will protect the teeth surfaces when assembling the parts.

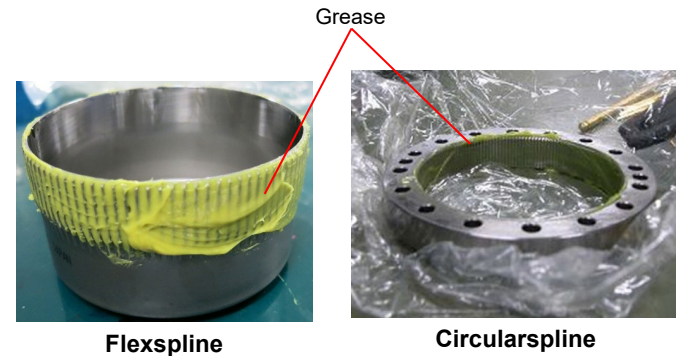

### 2.3.6 Installing the J2 Reduction Gear Unit

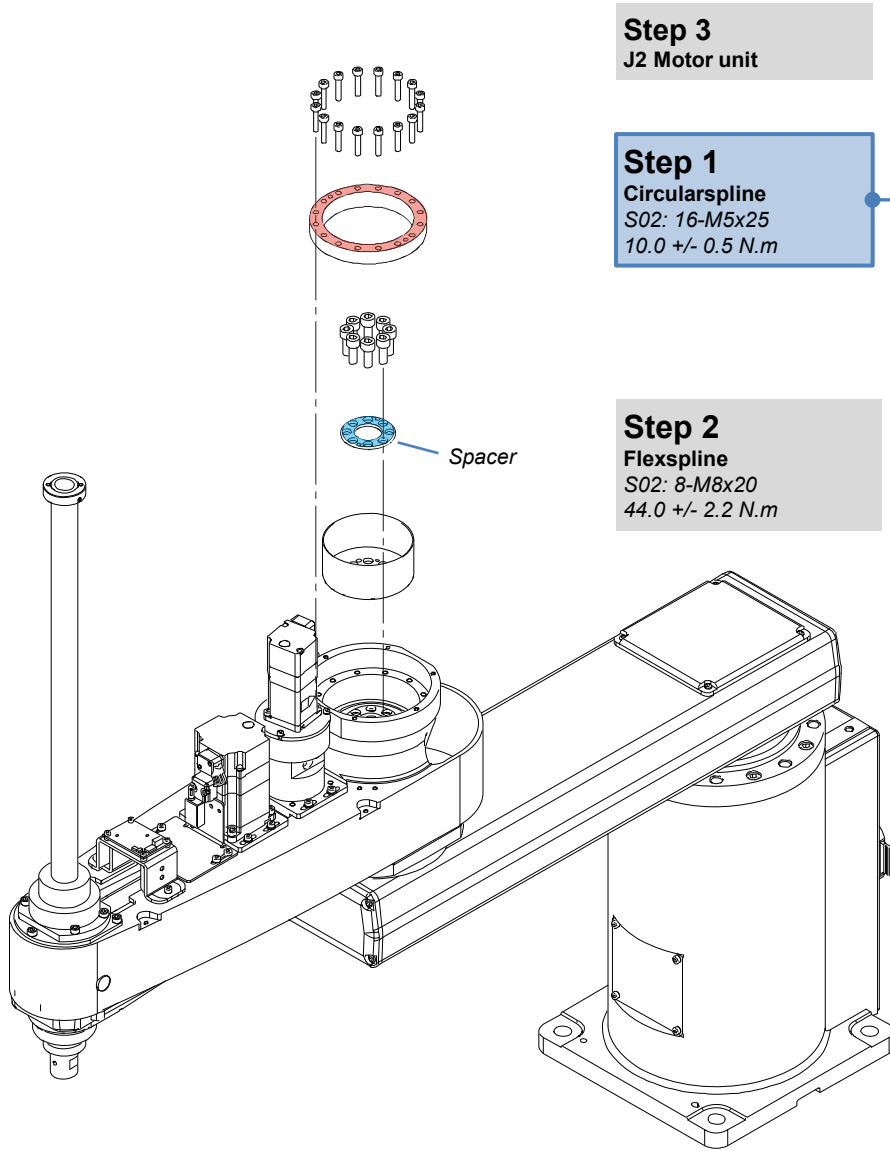

**Step 3**  
J2 Motor unit

**Step 1**  
Circularspline  
S02: 16-M5x25  
10.0 +/- 0.5 N.m

**Step 2**  
Flexspline  
S02: 8-M8x20  
44.0 +/- 2.2 N.m

Install the Circularspline with its convex surface towards the Arm2 side.



Secure the Circularspline to Arm2 with the 16 bolts.

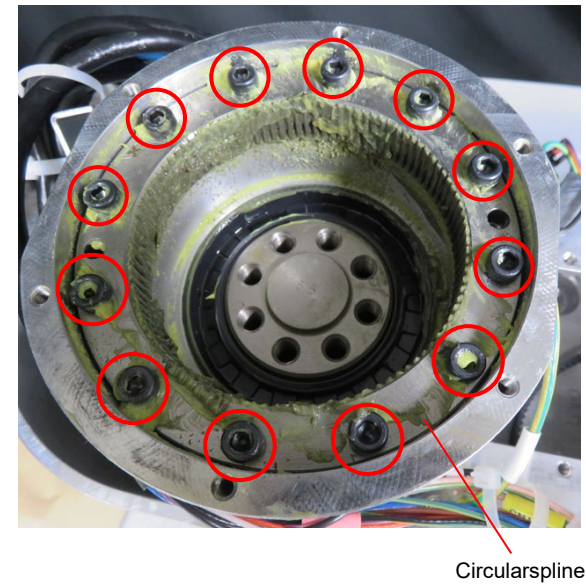



### 2.3.6 Installing the J2 Reduction Gear Unit

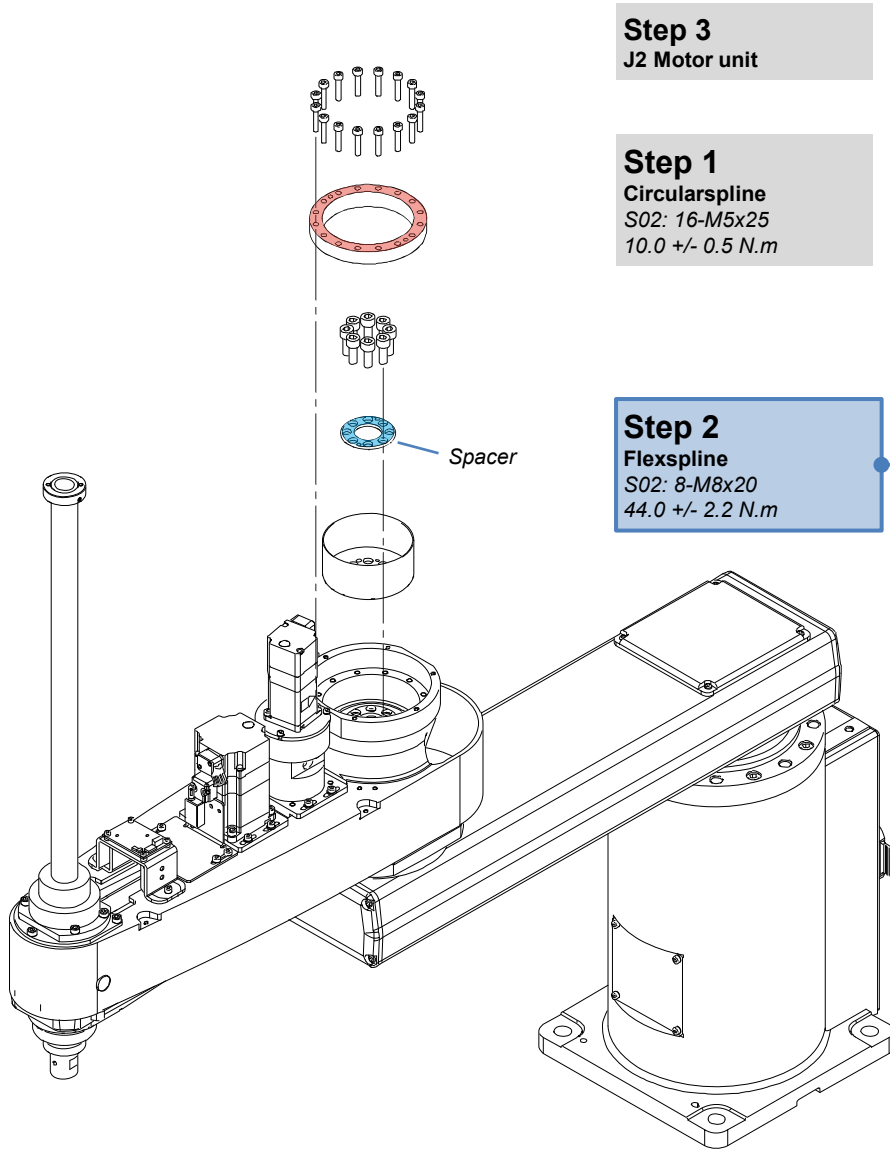

#### Installing the Flexspline

1. As shown in the figure, install two bolts into the tapped holes of the Flexspline.

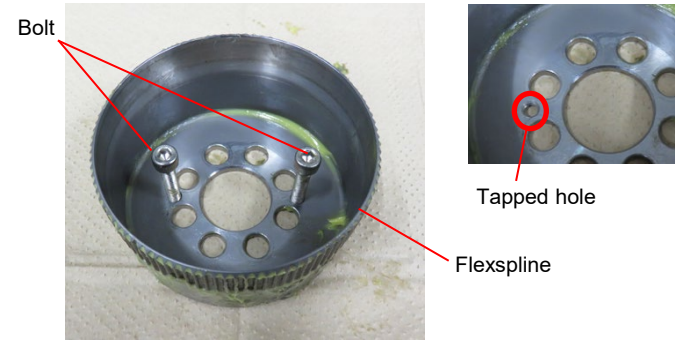

2. Place the Flexspline into the Circularspline at the circled locations below and then remove the bolts.

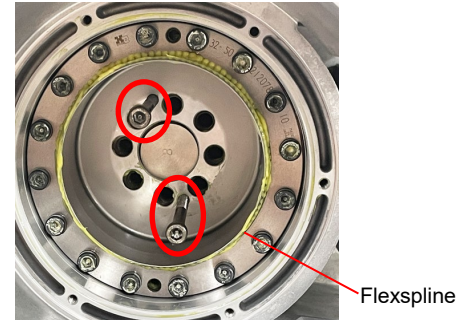

**CAUTION**

Make sure that the teeth of the Circularspline and Flexspline are properly engaged with each other.

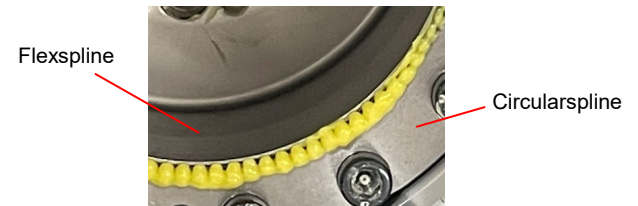

### 2.3.6 Installing the J2 Reduction Gear Unit

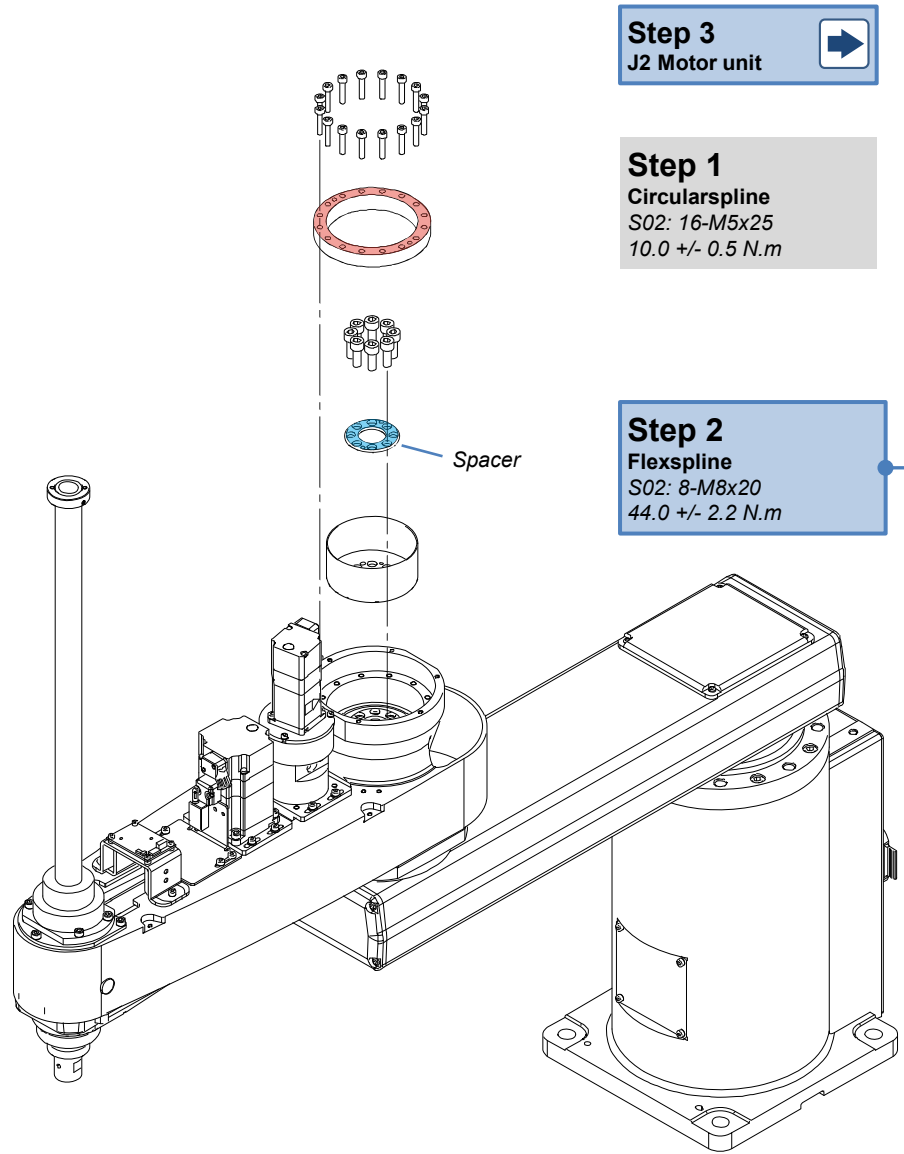

**Step 3**  
J2 Motor unit

**Step 1**  
Circularspline  
S02: 16-M5x25  
10.0 +/- 0.5 N.m

**Step 2**  
Flexspline  
S02: 8-M8x20  
44.0 +/- 2.2 N.m

- Set the Spacer with the positions of its air holes aligned with the tapped holes of the Flexspline. Secure the Flexspline and Spacer to Arm2.

**CAUTION**

Install the Spacer so that its air holes align with the tapped holes of the Flexspline. When the air holes are not in alignment, move Arm2 to the left and right to bring them into alignment. If the Spacer and Flexspline are installed incorrectly, this may cause pressure inside the Reduction Gear to rise and oil to leak.

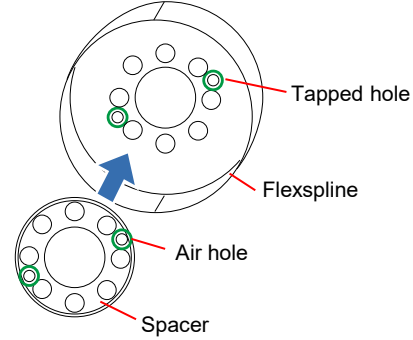

- Apply grease to the inside of the Flexspline.

 **SK-1A: 43 g**

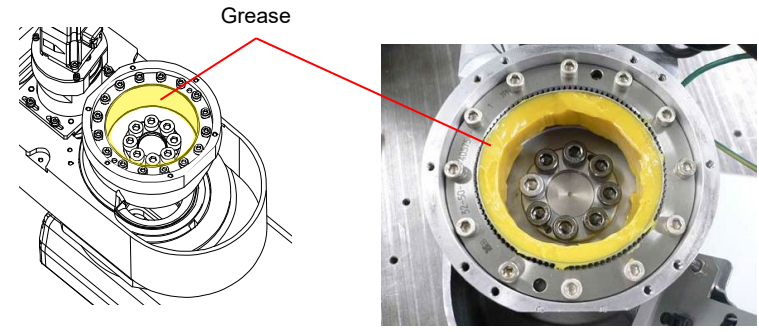

**CAUTION**

After assembling the motor unit, perform calibration of Joint #2.  
[3.1 Calibration](#)

## 2.4 Joint #3

### 2.4.1 Removing the J3 Motor Unit

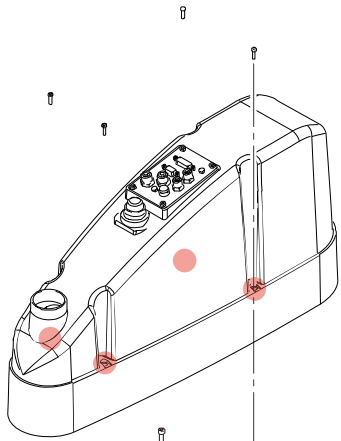

**Step 1**  
**Arm Upper Cover**  
 S03: 4-M4x15



**Step 2**  
**Connectors and cables**

**Step 4**  
**J3 Motor**  
 S01: 4-M4x15 and washer  
 S01: 2-M5x12  
 S01: 2-M5x20

**Step 3**  
**Plate**  
 S01: 3-M4x10

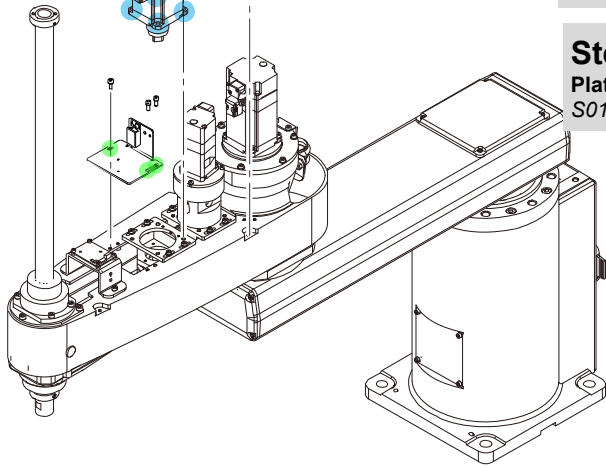

#### Disconnecting the Motor Connector

Disconnect the connector shown in the figure.

J3 Motor

CN131-1 (J3 Motor Power)



## 2.4.1 Removing the J3 Motor Unit

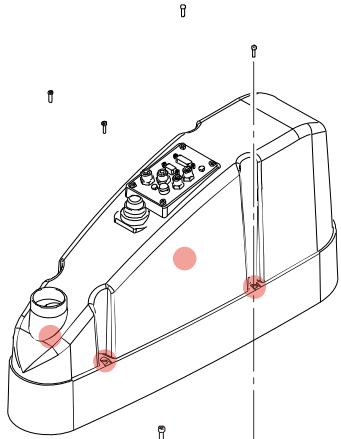

**Step 1**  
**Arm Upper Cover**  
 S03: 4-M4x15

**Step 2**  
**Connectors and cables**

**Step 4**  
**J3 Motor**  
 S01: 4-M4x15 and washer  
 S01: 2-M5x12  
 S01: 2-M5x20

**Step 3**  
**Plate**  
 S01: 3-M4x10

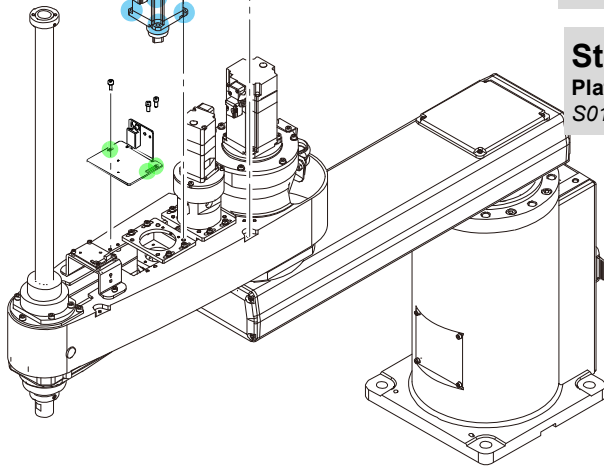

### Disconnecting the Motor Connector

Disconnect the connector, and remove the wire tie and Silicone Sheet shown in the figure.

J3 Motor  
 CN331-1 (J3 Motor Signal)  
 Silicone Sheet  
 Wire tie (AB150)

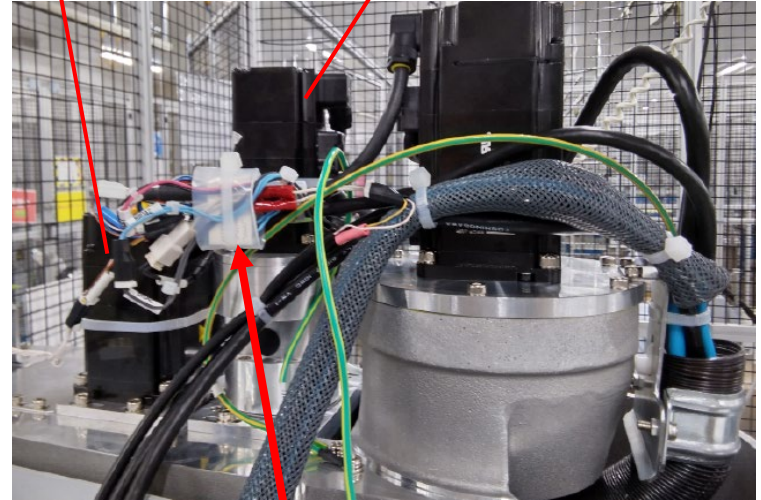

After removing the wire tie and Silicone Sheet, remove connector CN331-1 (J3 Motor Signal).

CN331-1 (J3 Motor Signal)

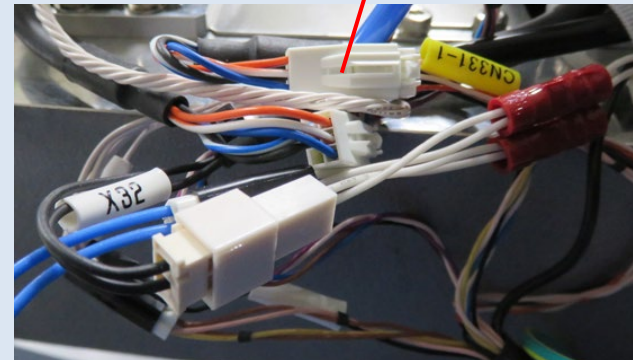

## 2.4.1 Removing the J3 Motor Unit

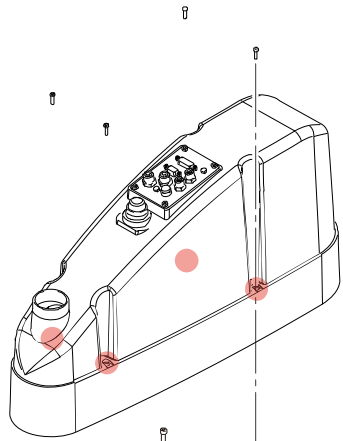

### Step 1

Arm Upper Cover  
S03: 4-M4x15

### Step 2

Connectors and cables

### Step 4

J3 Motor  
S01: 4-M4x15 and washer  
S01: 2-M5x12  
S01: 2-M5x20

### Step 3

Plate  
S01: 3-M4x10

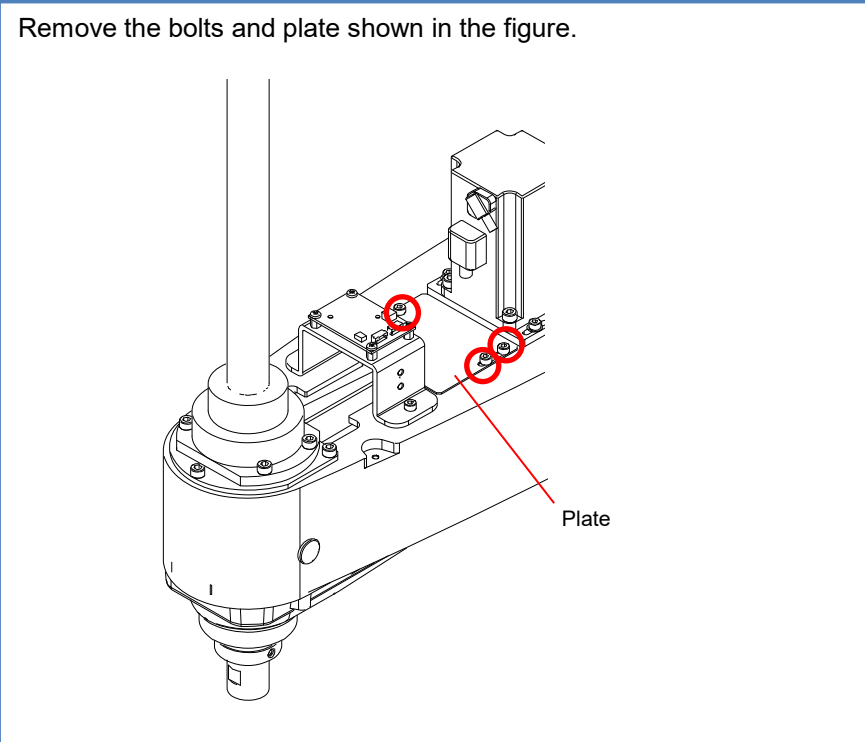



## 2.4.1 Removing the J3 Motor Unit

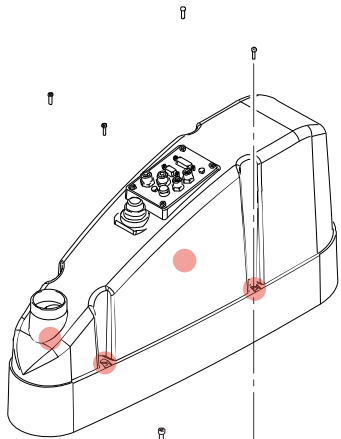

**Step 1**  
**Arm Upper Cover**  
 S03: 4-M4x15

**Step 2**  
**Connectors and cables**

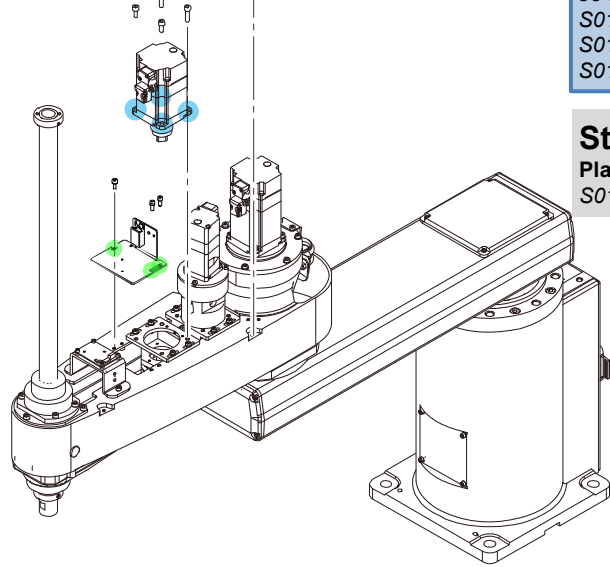

**Step 4**  
**J3 Motor**  
 S01: 4-M4x15 and washer  
 S01: 2-M5x12  
 S01: 2-M5x20

**Step 3**  
**Plate**  
 S01: 3-M4x10

### Removing the J3 Motor Unit

1. Loosen the four bolts securing the J3 Motor to Arm2, and slide the J3 Motor to the arm end side.  
 Remove the Z belt from the Z1 pulley.

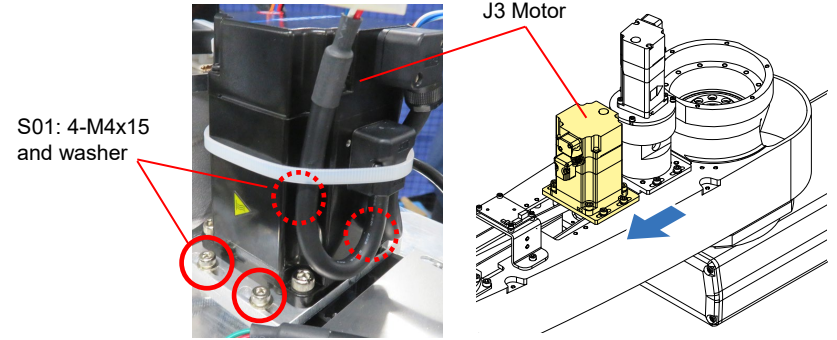

2. Remove the four bolts securing the J3 Motor and the Motor Plate, and remove the J3 Motor from Arm2.

**CAUTION**

Two types of bolts of differing lengths are used for the bolts securing the J3 Motor and the Motor Plate.

**POINT**

When it is difficult to remove the bolts securing the J3 Motor and the Motor Plate, cut the wire tie (AB200) securing the J3 Motor cable.

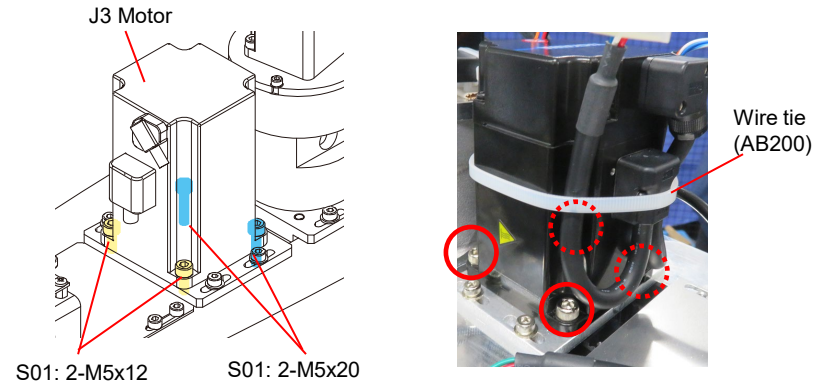

## 2.4.2 Installing the J3 Motor Unit

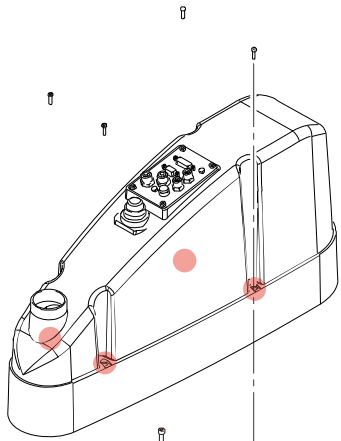

**Step 4**  
**Arm Upper Cover**  
 S03: 4-M4x15  
 0.45 +/- 0.1 N·m

**Step 3**  
**Connectors and cables**

**Step 2**  
**Plate**  
 S01: 3-M4x10  
 4.0 +/- 0.2 N·m

**Step 1**  
**J3 Motor**  
 S01: 2-M5x12  
 S01: 2-M5x20  
 8.0 +/- 0.4 N·m

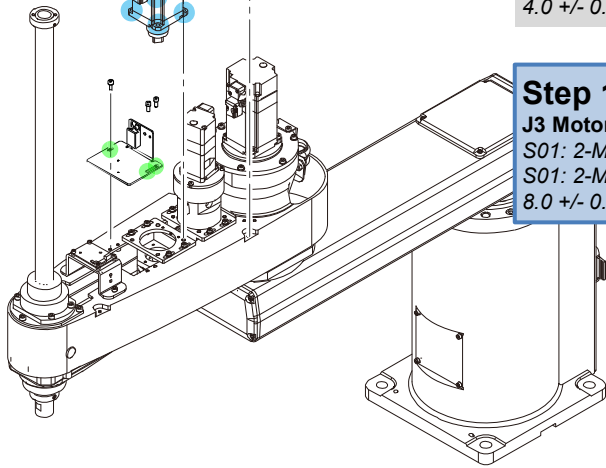

### CAUTION

- Attach the J3 Motor unit to the Brake Support according to the orientation shown in the figure.
- Two types of bolts of differing lengths are used for the bolts securing the J3 Motor and the Motor Plate.

### POINT

Install the J3 Motor while aligning the hub to the brake disk.

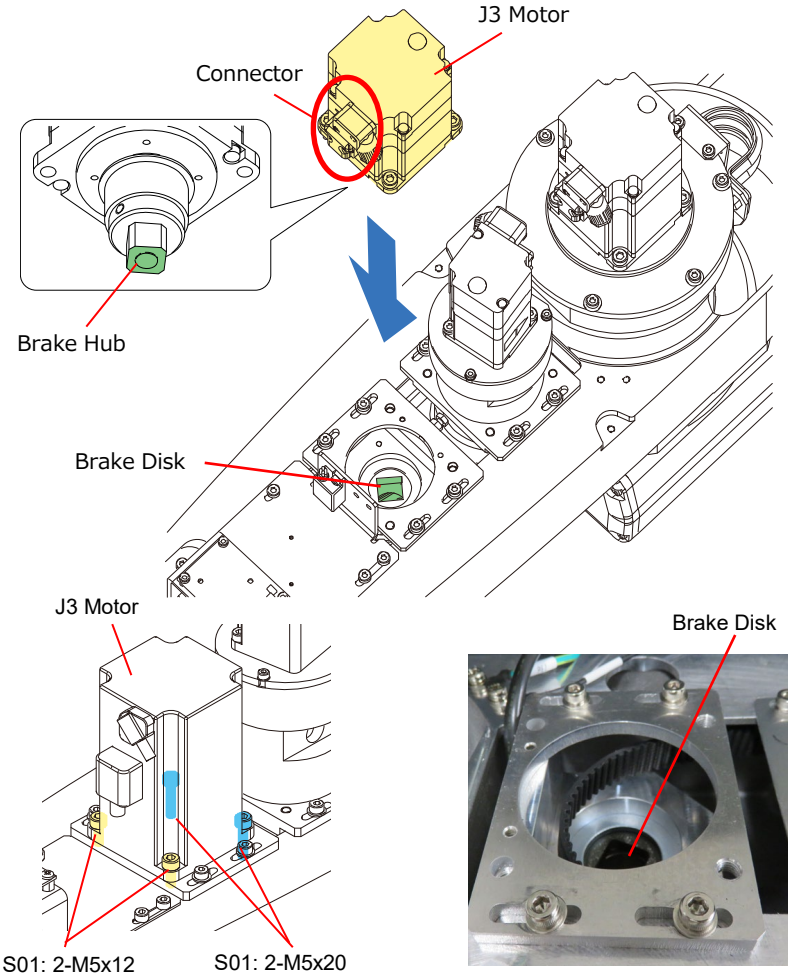

## 2.4.2 Installing the J3 Motor Unit

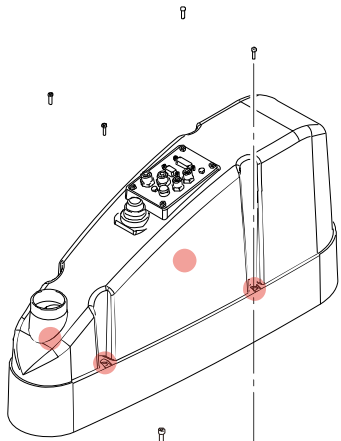

**Step 4**  
**Arm Upper Cover**  
 S03: 4-M4x15  
 0.45 +/- 0.1 N·m

**Step 3**  
**Connectors and cables**

**Step 2**  
**Plate**  
 S01: 3-M4x10  
 4.0 +/- 0.2 N·m

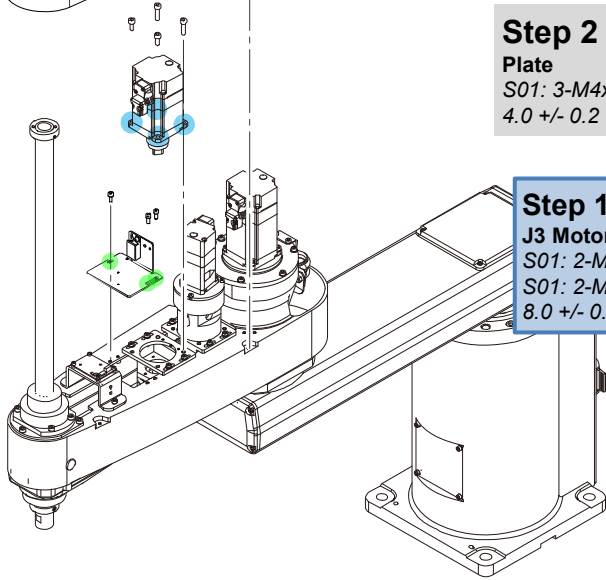

**Step 1**  
**J3 Motor unit**  
 S01: 2-M5x12  
 S01: 2-M5x20  
 8.0 +/- 0.4 N·m

### CAUTION

- Place the Z belt on the Z1 and Z2 pulleys. Make sure that the teeth of the belt and pulley are properly engaged.
- When the Z belt comes away from the Z2 pulley, re-attach the Z belt on the Z2 pulley by referring to the procedure in [2.4.5. Installing the J3 Timing Belt \(Z\)](#).

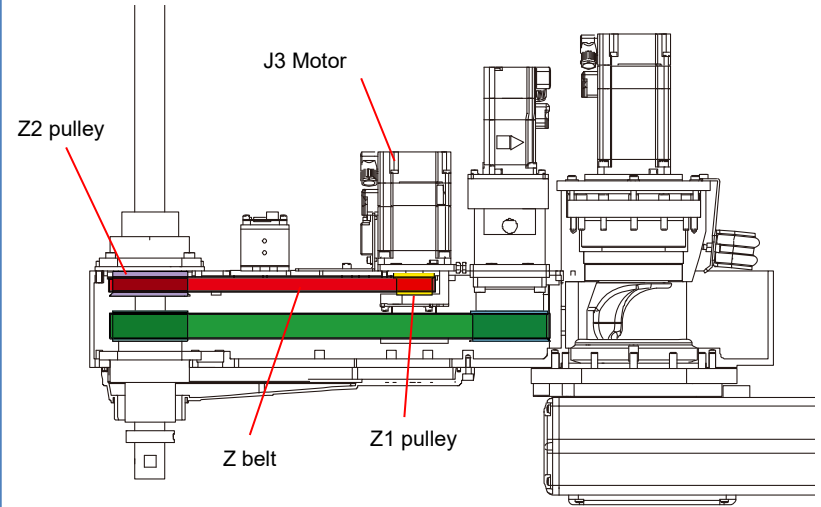

- If the Timing Belt is placed on the flange, correct tension will not be obtained during belt tension adjustment.

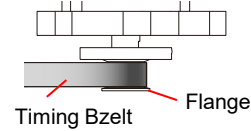

Set the belt so that it is level with respect to the pulley without it being placed on the flange.

### POINT

Temporarily tighten the motor unit fixing bolts until the motor unit can slide freely to adjust the belt tension.

### Belt tension adjustment

Adjust the belt tension after installing the motor unit.

[3.2 Adjusting the Timing Belt Tension](#)



## 2.4.2 Installing the J3 Motor Unit

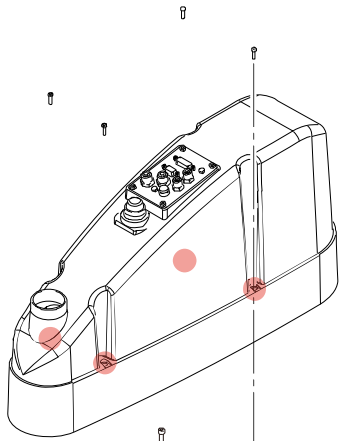

**Step 4**  
**Arm Upper Cover**  
 S03: 4-M4x15  
 0.45 +/- 0.1 N·m

**Step 3**  
**Connectors and cables**

**Step 2**  
**Plate**  
 S01: 3-M4x10  
 4.0 +/- 0.2 N·m

**Step 1**  
**J3 Motor unit**  
 S01: 2-M5x12  
 S01: 2-M5x20  
 8.0 +/- 0.4 N·m

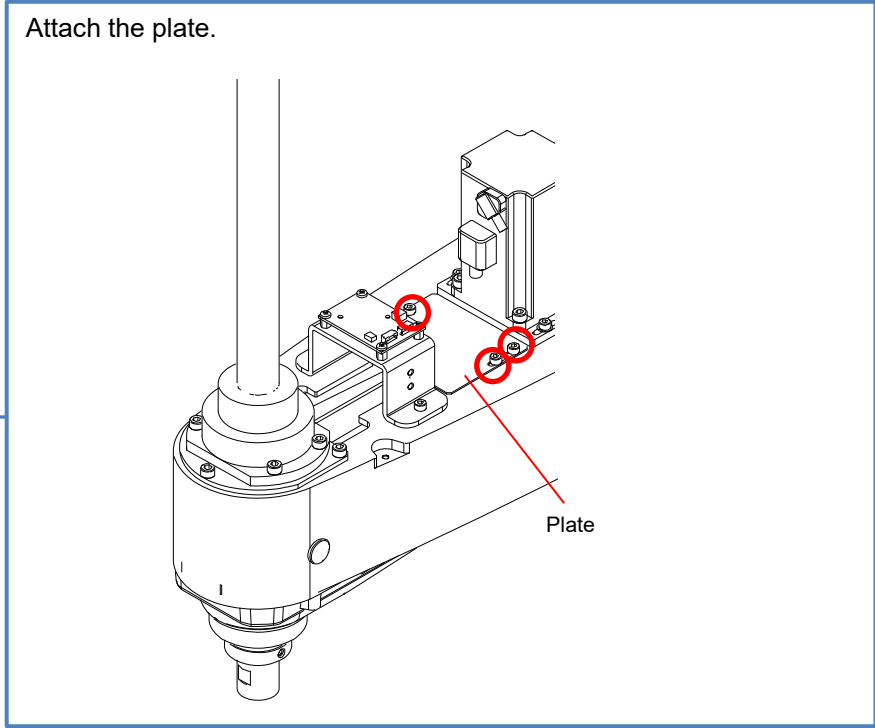

## 2.4.2 Installing the J3 Motor Unit

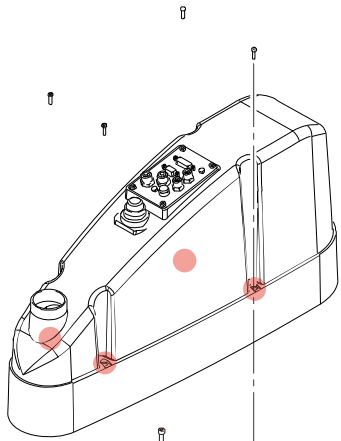

**Step 4**  
**Arm Upper Cover**  
 S03: 4-M4x15  
 0.45 +/- 0.1 N·m

**Step 3**  
**Connectors and cables**

**Step 2**  
**Plate**  
 S01: 3-M4x10  
 4.0 +/- 0.2 N·m

**Step 1**  
**J3 Motor unit**  
 S01: 2-M5x12  
 S01: 2-M5x20  
 8.0 +/- 0.4 N·m

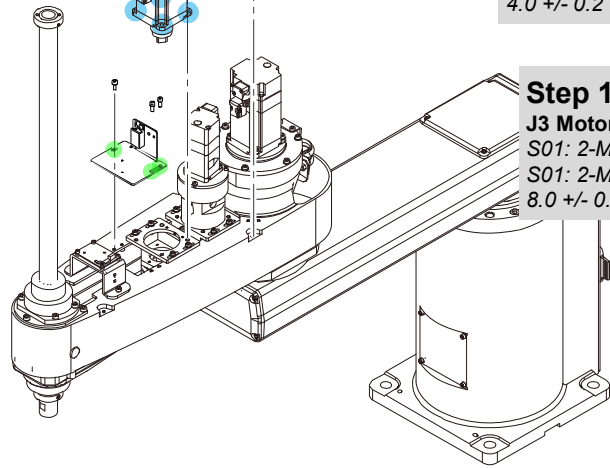

### Installing the Connector and Cables

Connect the connector shown in the figure.

**CAUTION**

Take care not to apply a load to the cables, for example, by bending the cables with excessive force.

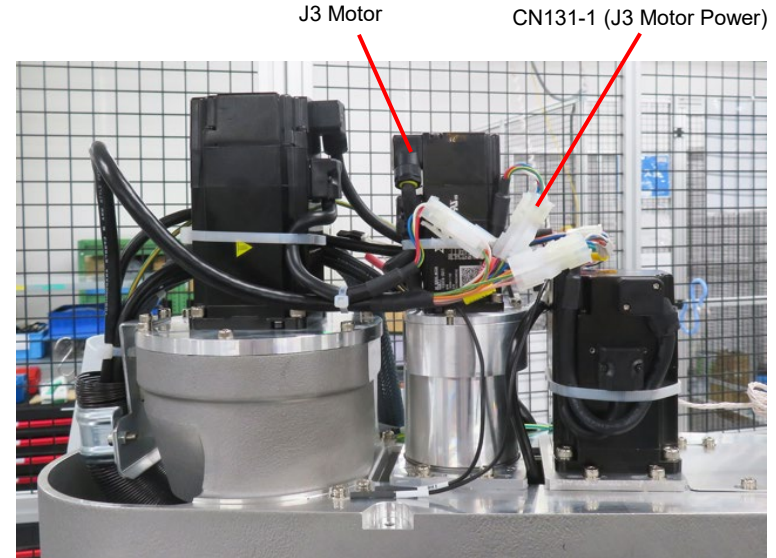

## 2.4.2 Installing the J3 Motor Unit

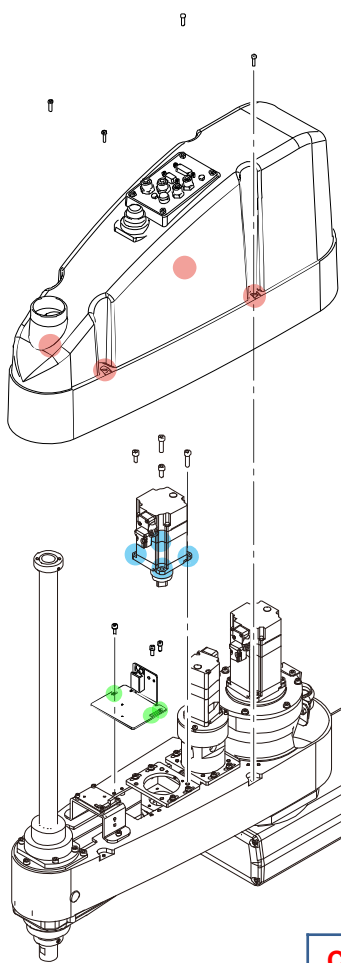

**Step 4**  
**Arm Upper Cover**  
 S03: 4-M4x15  
 0.45 +/- 0.1 N·m

**Step 3**  
**Connectors and cables**

**Step 2**  
**Plate**  
 S01: 3-M4x10  
 4.0 +/- 0.2 N·m

**Step 1**  
**J3 Motor unit**  
 S01: 2-M5x12  
 S01: 2-M5x20  
 8.0 +/- 0.4 N·m

**CAUTION**  
 After performing the maintenance procedure,  
 perform calibration of Joint #3.  
[3.1 Calibration](#)

**Connecting the Motor Unit Connectors**  
 Wrap CN331-1 with the Silicone Sheet together with the other connectors and cables, and secure them with a wire tie (AB150).  
**CAUTION**  
 Take care not to apply a load to the cables, for example, by bending the cables with excessive force.

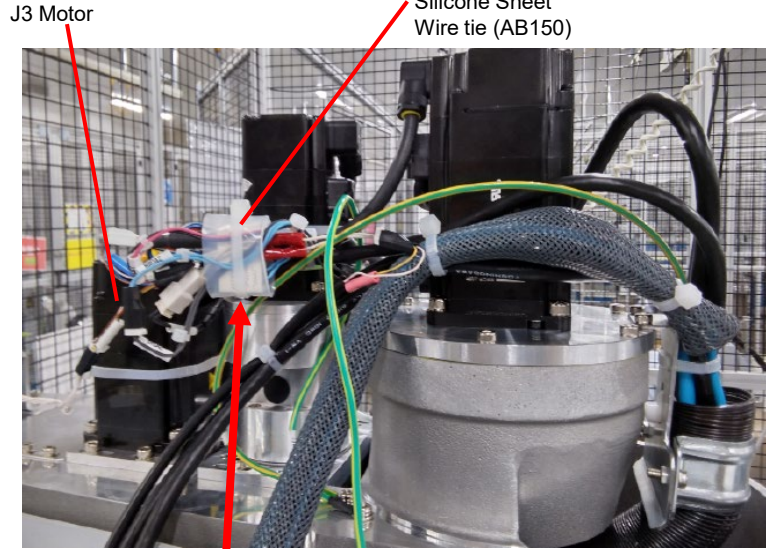

Wrap the connectors and cables shown in the figure with the Silicone Sheet.  
 CN331-1 (J3 Motor Signal)

### 2.4.3 Replacing the J3 Motor Unit Unit

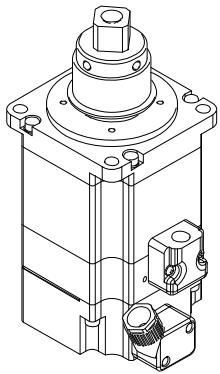

J3 Motor unit

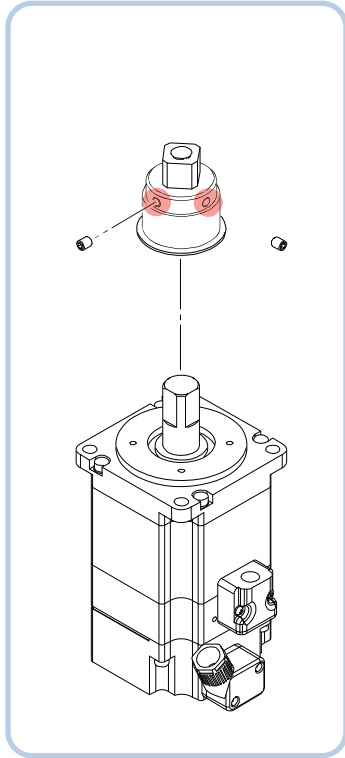

#### Step 1

Motor pulley  
S05: 2-M4x5  
2.4 +/- 0.1 N·m

#### Installation

Insert the motor pulley until it contacts the end face of the motor shaft.

Align the pulley screws with the D-Cuts of the motor shaft and secure the screws.

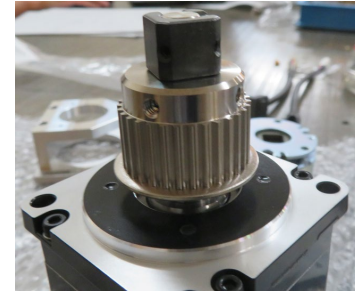
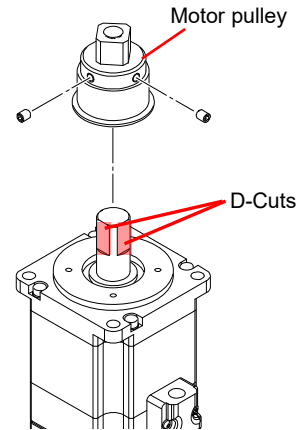

\* The disassembly procedure is described here.  
Perform assembly by following the disassembly procedure  
in the reverse order.

### 2.4.4 Removing the J3 Timing Belt (Z)

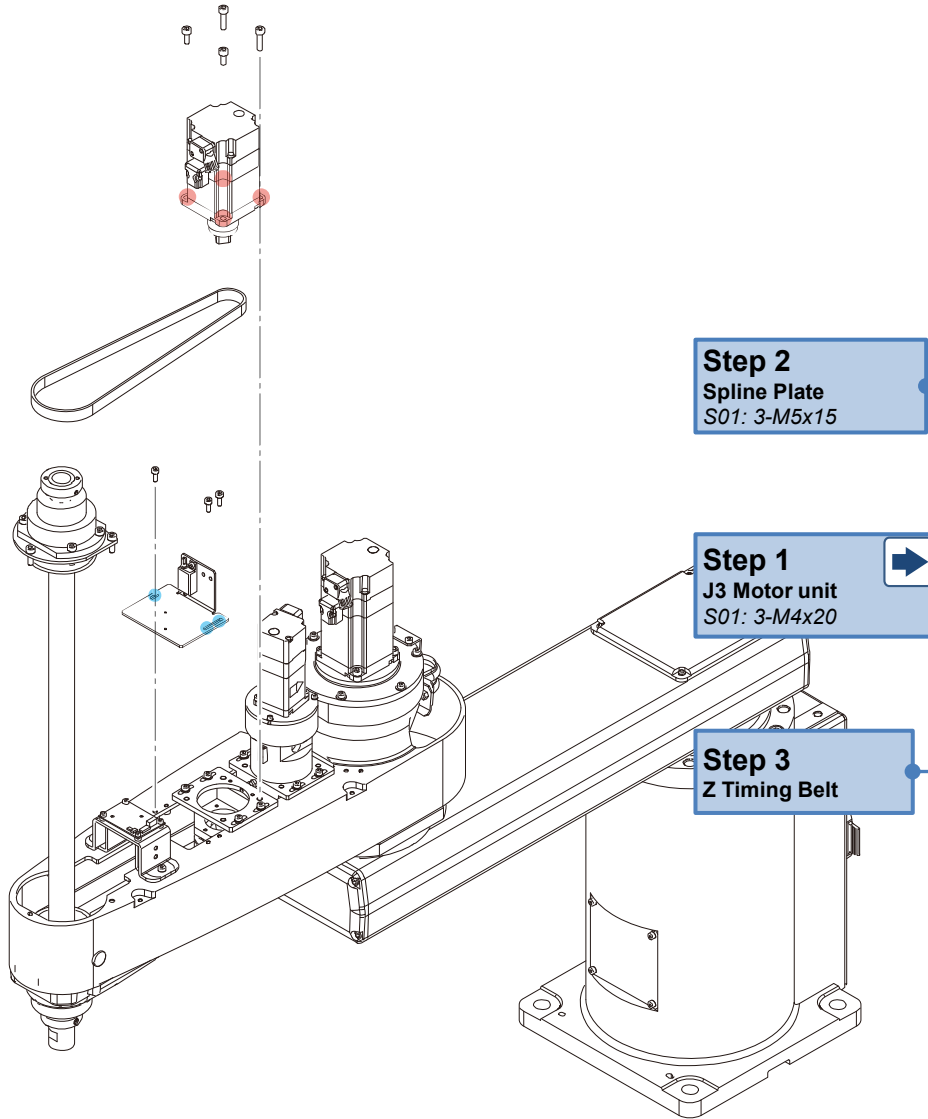

**CAUTION**

The Ball Screw Spline Unit may fall while performing maintenance. Before performing maintenance, lower it to the lower limit.

**POINT**

Remove the bolts securing the Spline Plate.

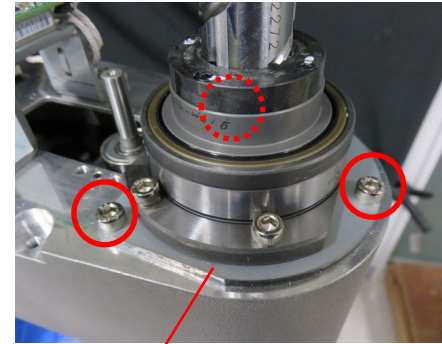

Spline Plate

**POINT**

Lift up the Spline Plate, and draw the Z belt upwards from the shaft.

### 2.4.5 Installing the J3 Timing Belt (Z)

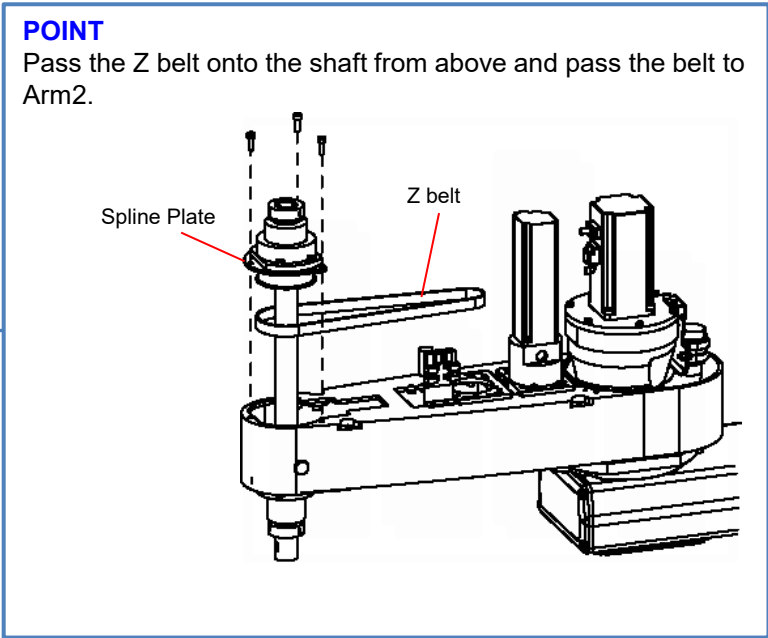
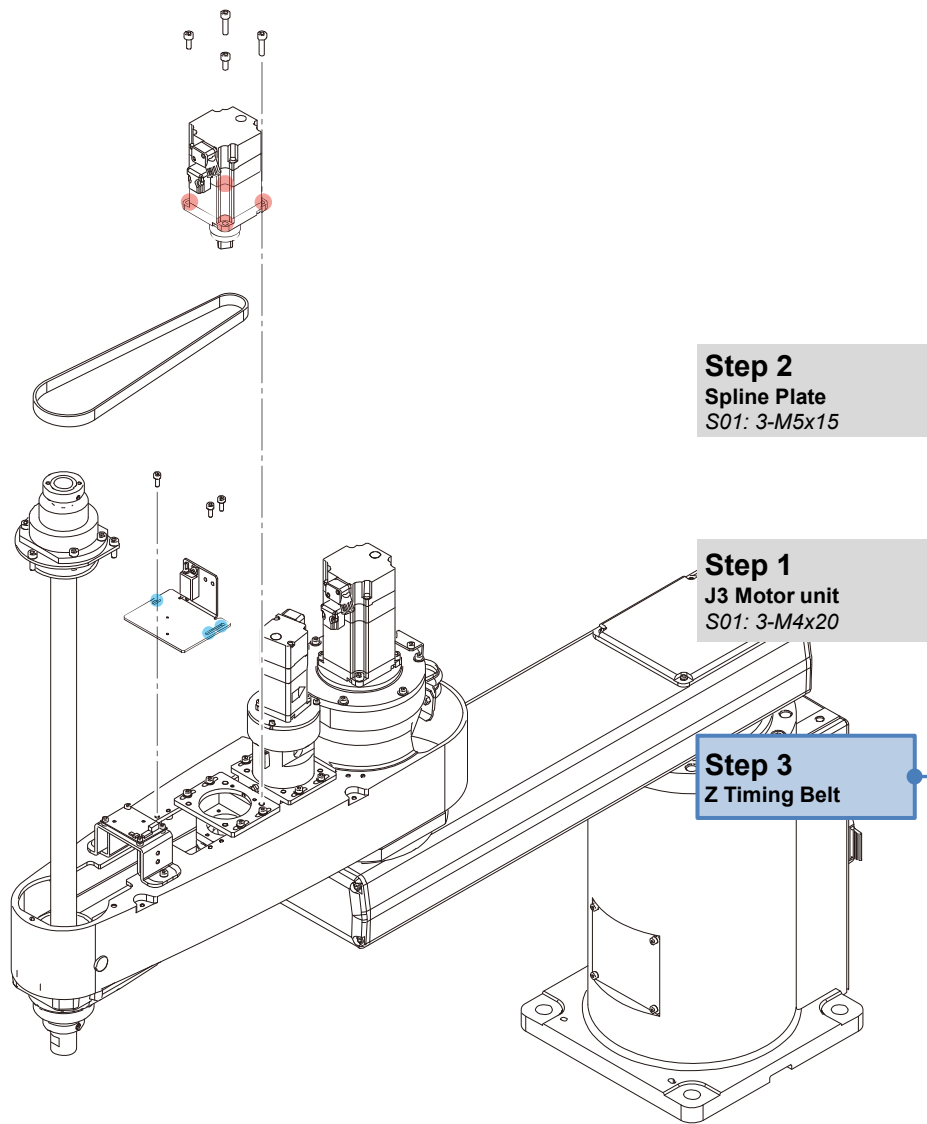



## 2.4.5 Installing the J3 Timing Belt (Z)

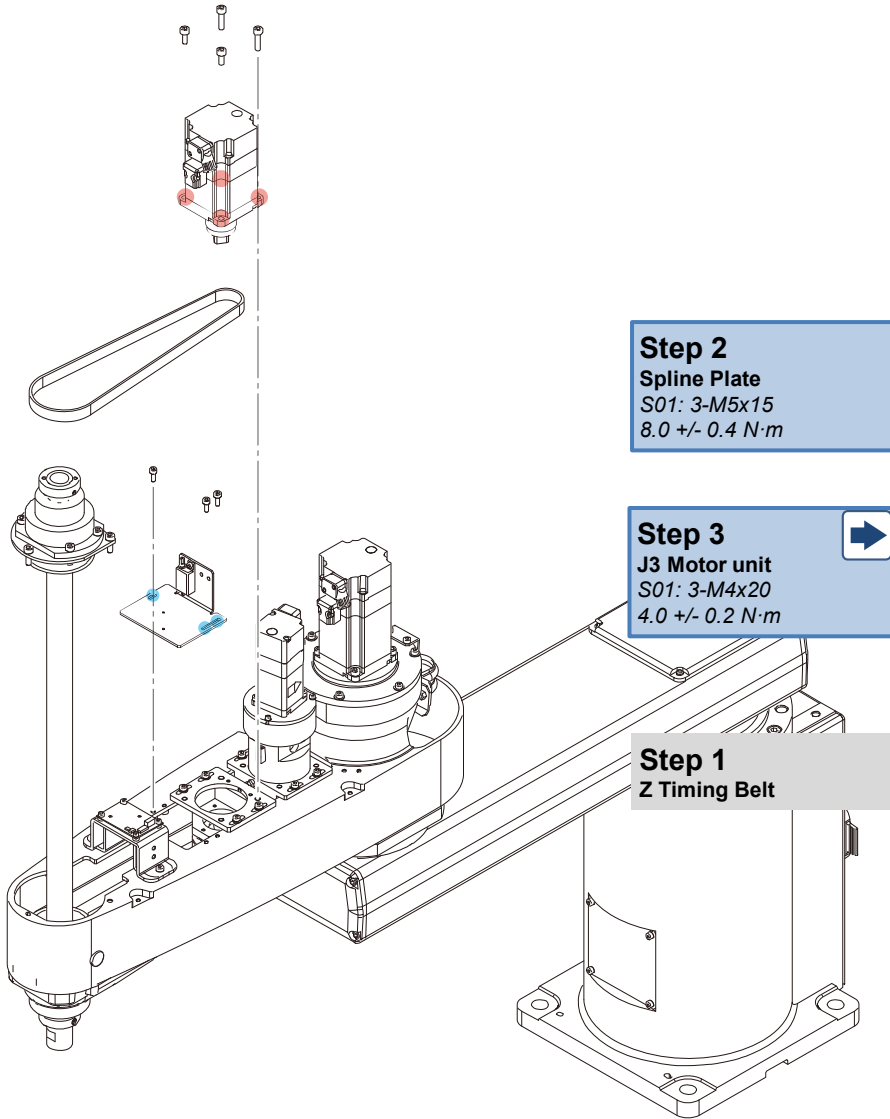

### POINT

Temporarily secure the Spline Plate on Arm2.

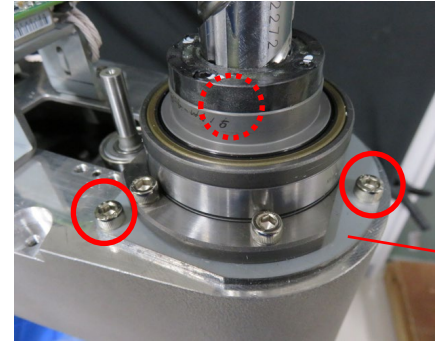

Spline Plate

### CAUTION

Take care to prevent the Timing Belt from being caught between the nut and Arm2.

After temporary tightening, perform centering.

Move the Ball Screw Spline Unit up and down. The Ball Screw Spline Unit will be positioned to the center of the arm.

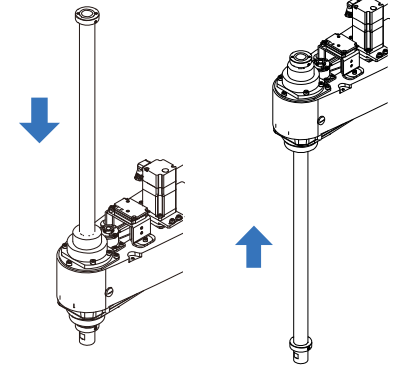

### CAUTION

After performing centering, fix the Spline Plate.

### CAUTION

After performing the maintenance procedure, perform calibration of Joint #3.

[3.1 Calibration](#)

## 2.4.6 Removing the J3 Brake

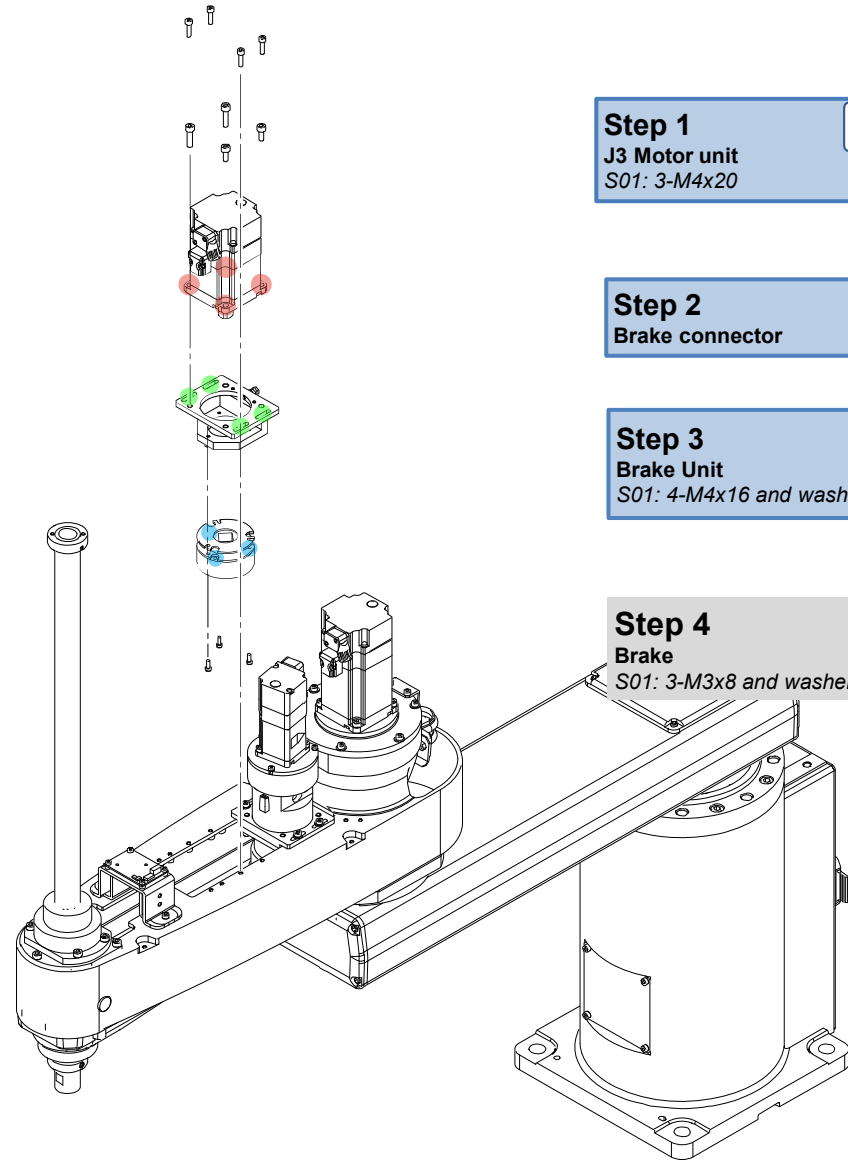

**Step 1**  
**J3 Motor unit**  
*S01: 3-M4x20*

**Step 2**  
**Brake connector**

**Step 3**  
**Brake Unit**  
*S01: 4-M4x16 and washer*

**Step 4**  
**Brake**  
*S01: 3-M3x8 and washer*

Remove the four bolts shown in the figure, and remove the Brake Unit from Arm2.

The photograph shows a close-up of the Brake Support with four bolts circled in red. The diagram shows the Brake Unit being removed from the Arm2 assembly.

**Removing the Brake Connector**  
 Disconnect the connector shown in the figure.

The photograph shows the Brake Connector (X32) being disconnected from the wiring. The connector is labeled X32 (J3 Brake).



## 2.4.6 Removing the J3 Brake

**Step 1**  
J3 Motor unit  
S01: 3-M4x20

**Step 2**  
Brake connector

**Step 3**  
Brake Unit  
S01: 4-M4x16 and washer

**Step 4**  
Brake  
S01: 3-M3x8 and washer

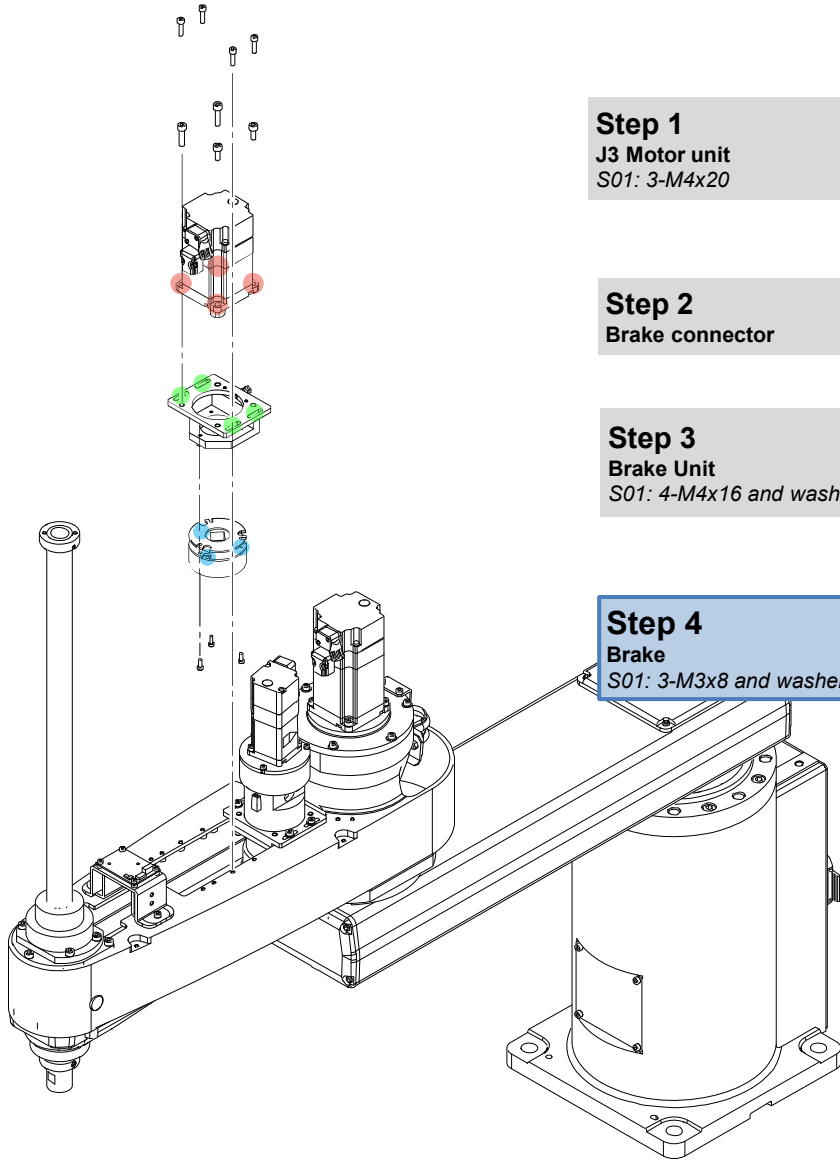

Remove the brake from the Brake Support.

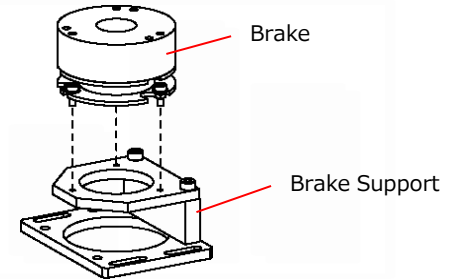

**POINT**

Pass the hexagonal wrench through the hole on the brake, and remove the bolt securing the Brake Support and the brake.

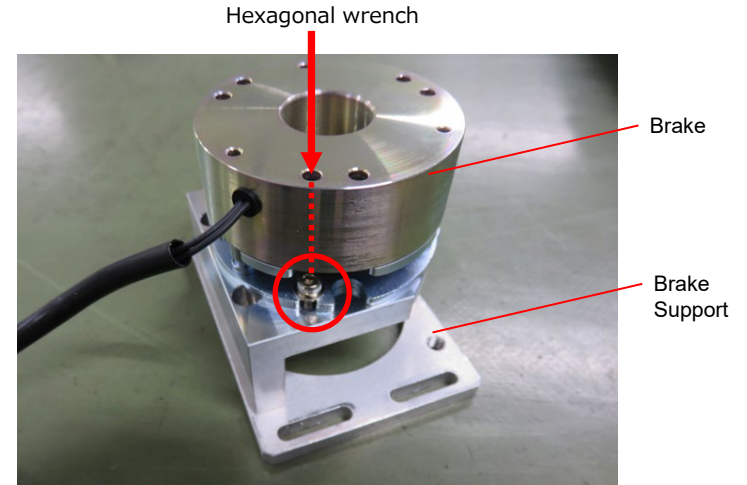

### 2.4.7 Installing the J3 Brake

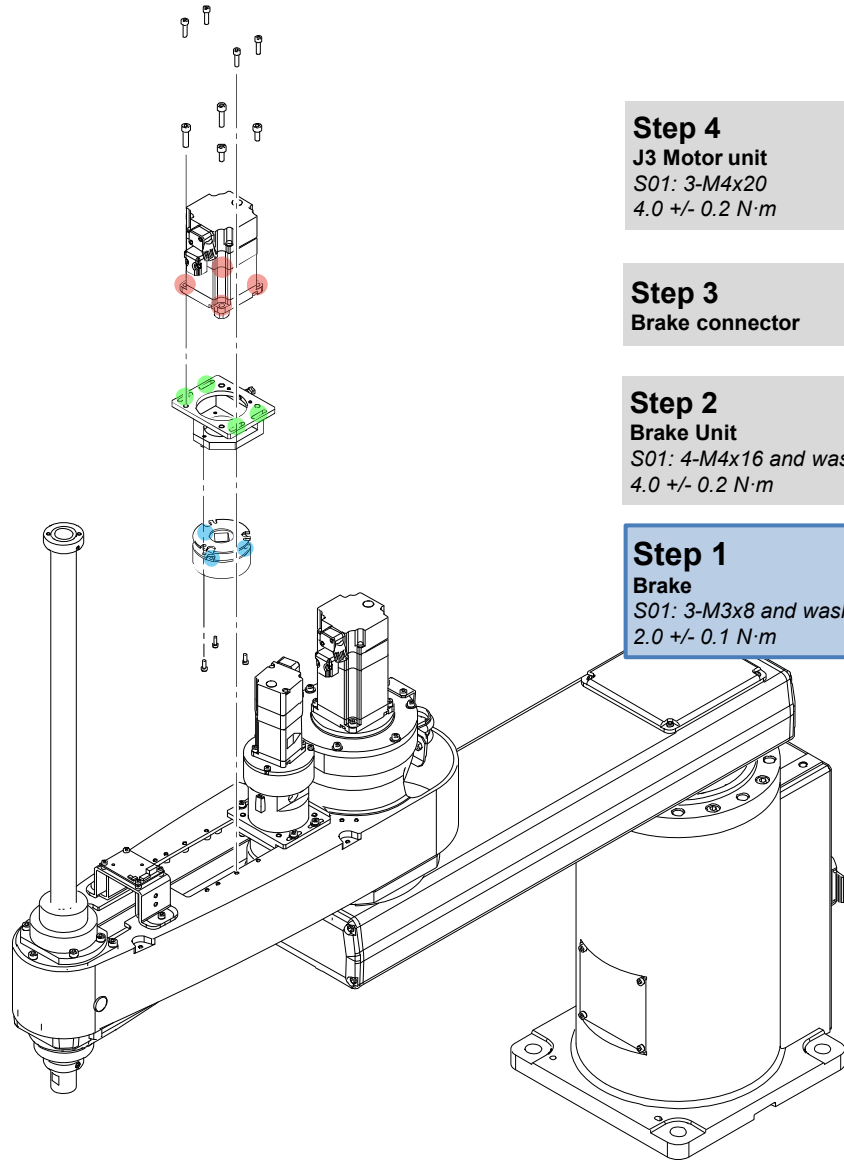

**Step 4**  
**J3 Motor unit**  
 S01: 3-M4x20  
 4.0 +/- 0.2 N·m

**Step 3**  
**Brake connector**

**Step 2**  
**Brake Unit**  
 S01: 4-M4x16 and washer  
 4.0 +/- 0.2 N·m

**Step 1**  
**Brake**  
 S01: 3-M3x8 and washer  
 2.0 +/- 0.1 N·m

Install the brake in such a way that the brake cable is positioned as shown in the figure with respect to the Brake Support.

**POINT**  
 Pass the hexagonal wrench through the hole on the brake, and tighten the screw to secure the brake on the Brake Support.

The photograph shows a close-up of the brake assembly. A red arrow labeled 'Hexagonal wrench' points to a hole in the top of the brake. A red circle highlights a screw on the brake support. A red line labeled 'Brake' points to the brake unit. A red line labeled 'Brake Support' points to the metal base. A red line labeled 'Brake cable' points to the black cable connected to the brake.

## 2.4.7 Installing the J3 Brake

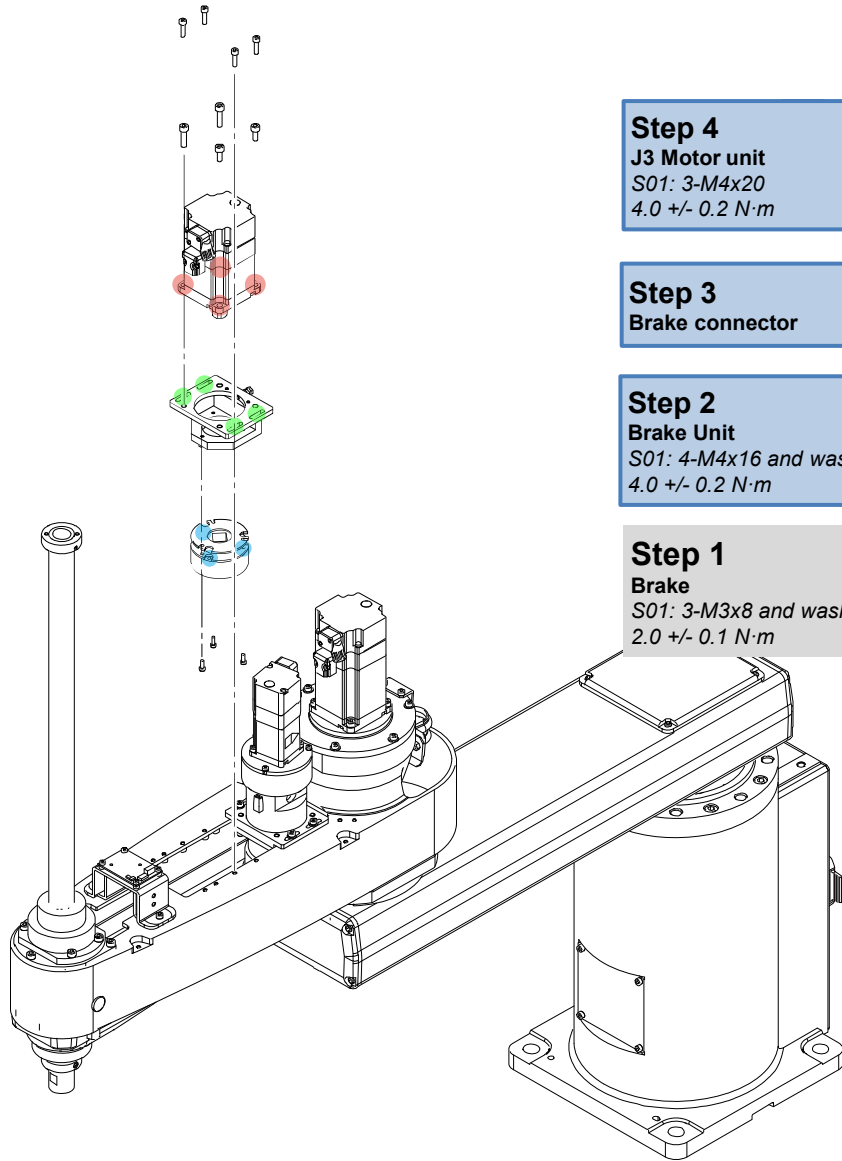

### Installing the Brake Connector

Connect the connector shown in the figure.

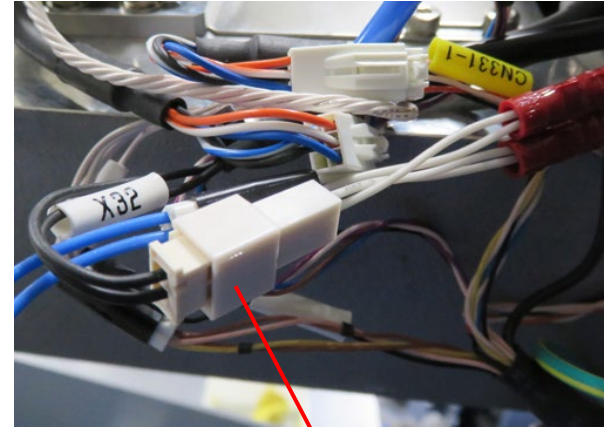

X32 (J3 Brake)

Replace and temporarily secure the Brake Unit on Arm2.

### POINT

In this procedure, do not secure the screws in place. Secure them in "Step 4 J3 Motor unit."

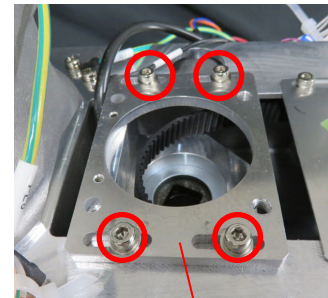

Brake Support

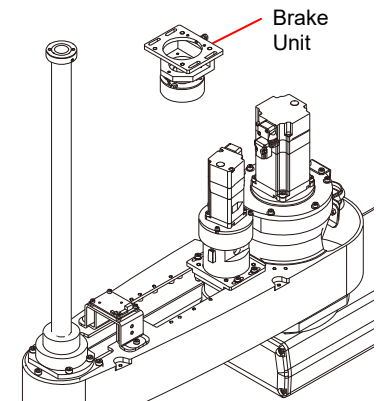

## 2.5 Joint #4

### 2.5.1 Removing the J4 Motor Unit

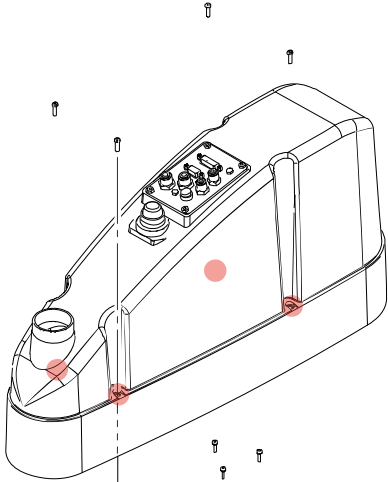

**Step 1**  
 Arm Upper Cover  
 S03: 4-M4x15



**Step 2**  
 Connectors and cables

**Step 3**  
 J4 Motor unit  
 S01: 3-M3x12

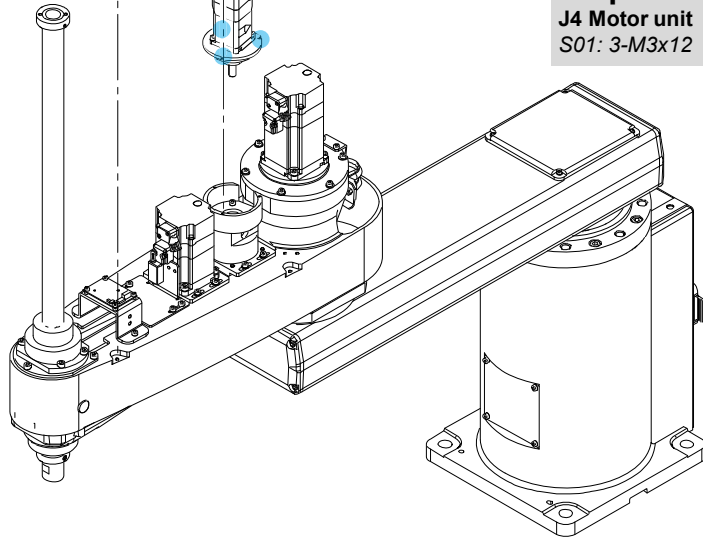

**Disconnecting the Connectors and Cables**  
 Disconnect the connectors shown in the figure.

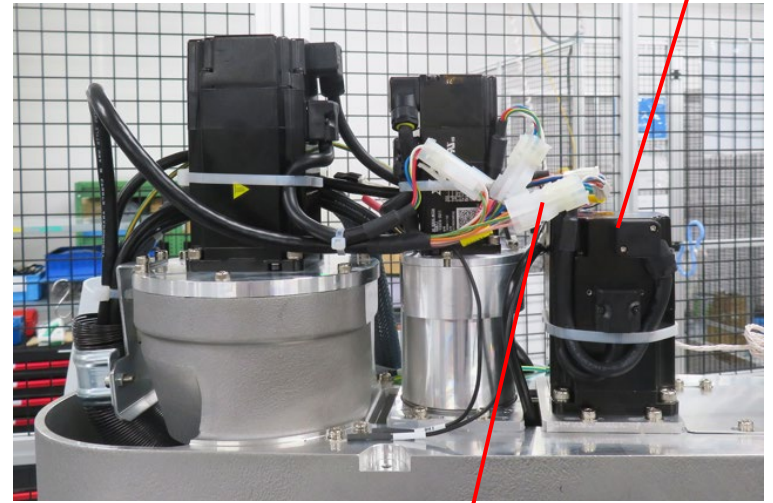

J4 Motor

CN141-1 (J4 Motor Power)

CN341-1 (J4 Motor Signal)  
 CN440-1 (J4 Brake)  
 Silicone Sheet  
 Wire tie (AB150)

J4 Motor

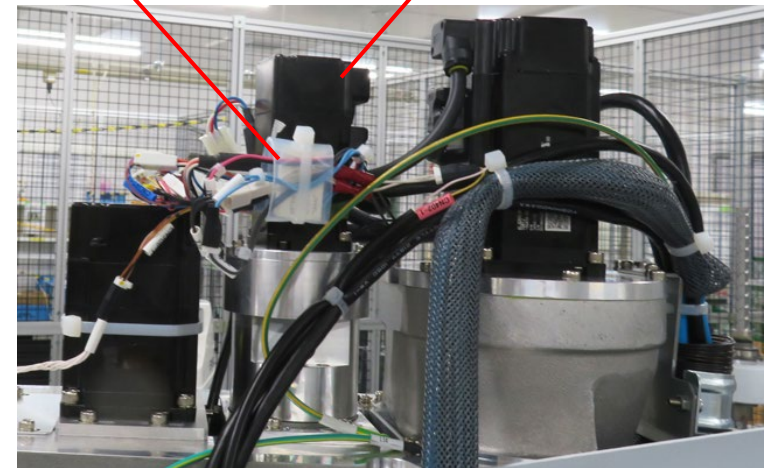



## 2.5.1 Removing the J4 Motor Unit

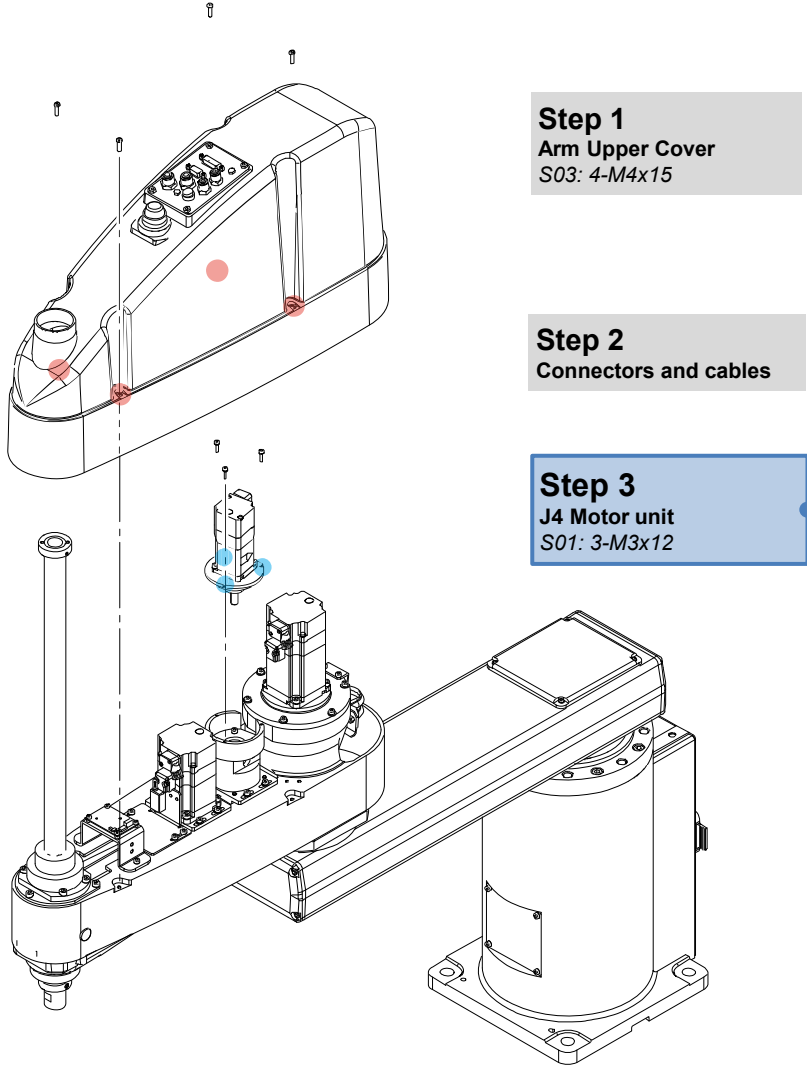

### Removing the J4 Motor Unit

1. Remove the screws shown in the figure.  
S01: 3-M3x12

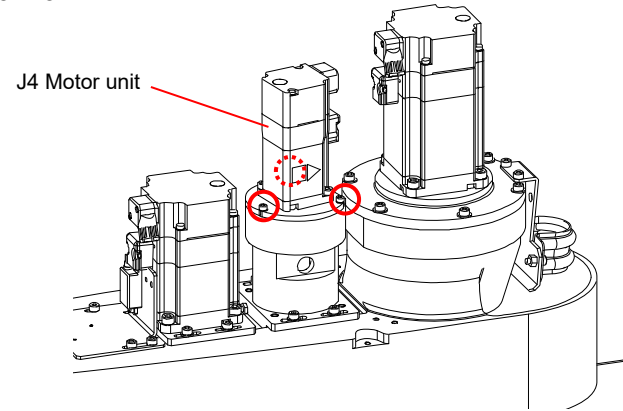

2. Remove the cover, and loosen the screw securing the extension shaft.

**POINT**

When the screw position is not aligned, turn the motor body slightly to bring the screw position into alignment.

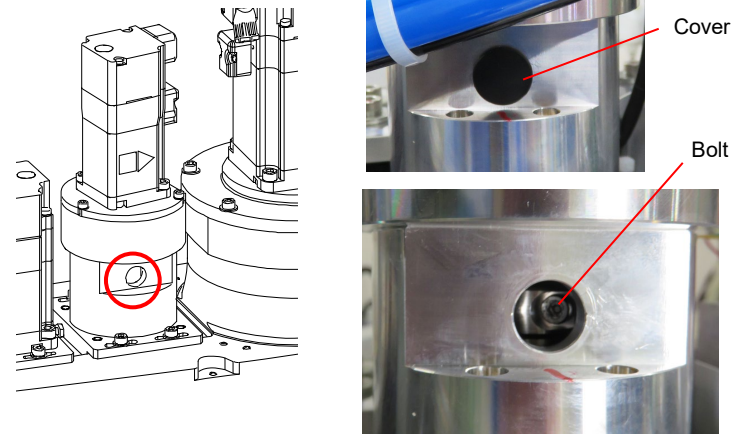

## 2.5.1 Removing the J4 Motor Unit

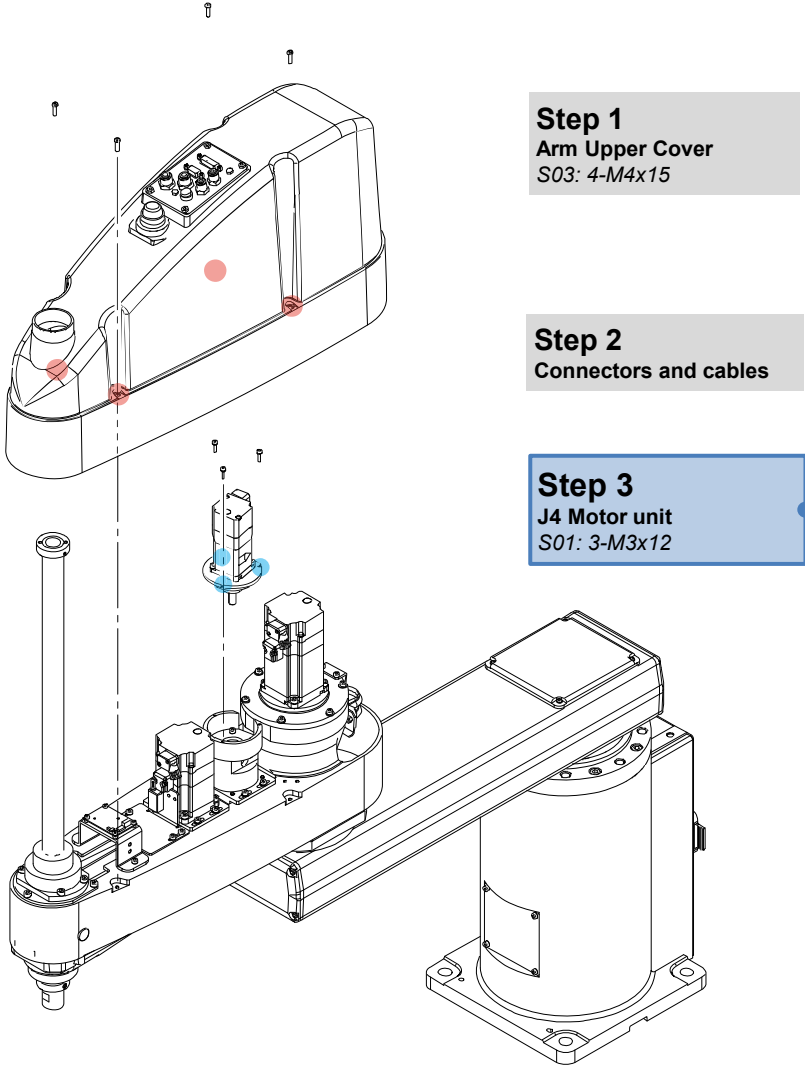

3. Remove the J4 Motor unit from the Reduction Gear.

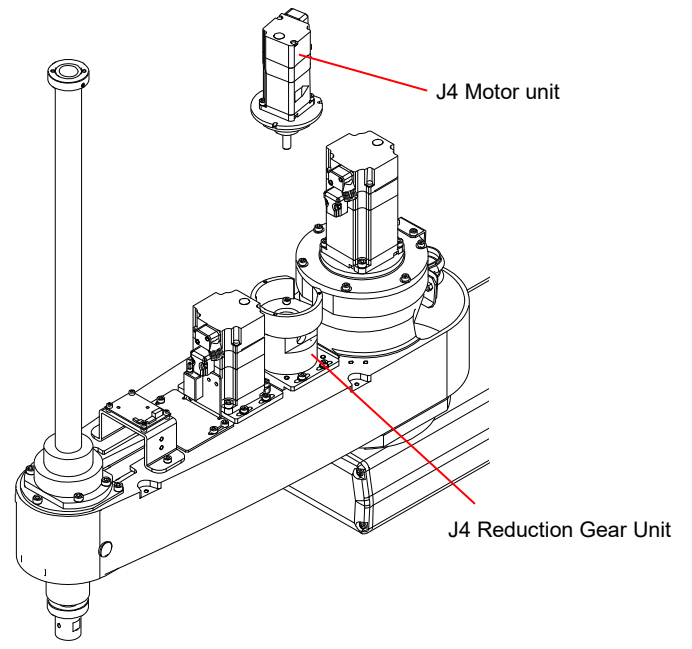

## 2.5.2 Installing the J4 Motor Unit

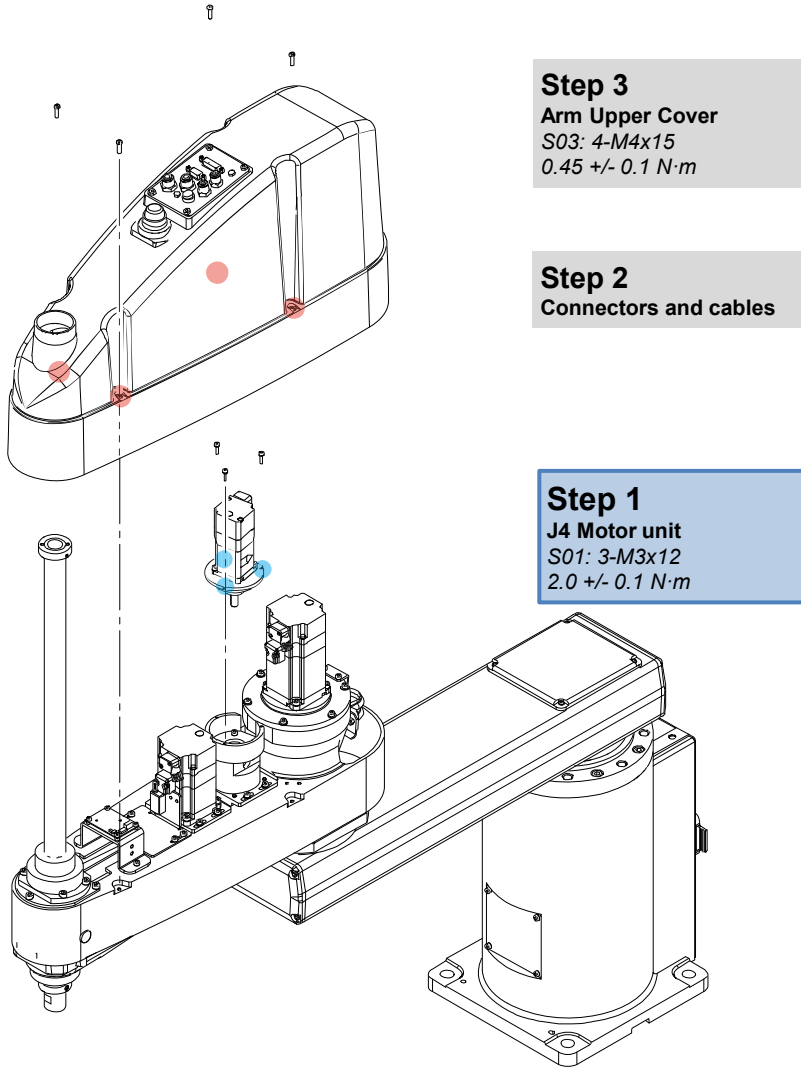

### Installing the J4 Motor Unit

1. Insert the extension shaft of the J4 Motor unit into the Reduction Gear.

**POINT**

Insert the extension shaft in the orientation where the motor connector comes to the Joint #2 side.

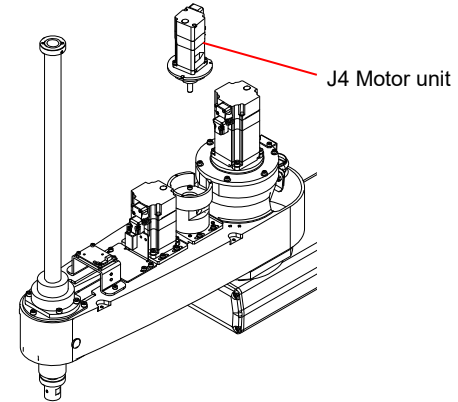

2. Temporarily secure the Motor Plate to the U housing with bolts (M3x12), and loosen the motor securing bolts (M4x10) to temporarily secure the motor.

**POINT**

As a rule, temporarily fasten to the extent that the motor unit can be moved by hand and does not tilt over.

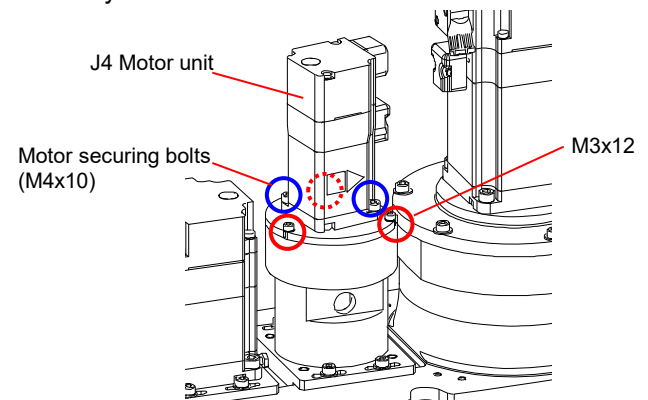

## 2.5.2 Installing the J4 Motor Unit

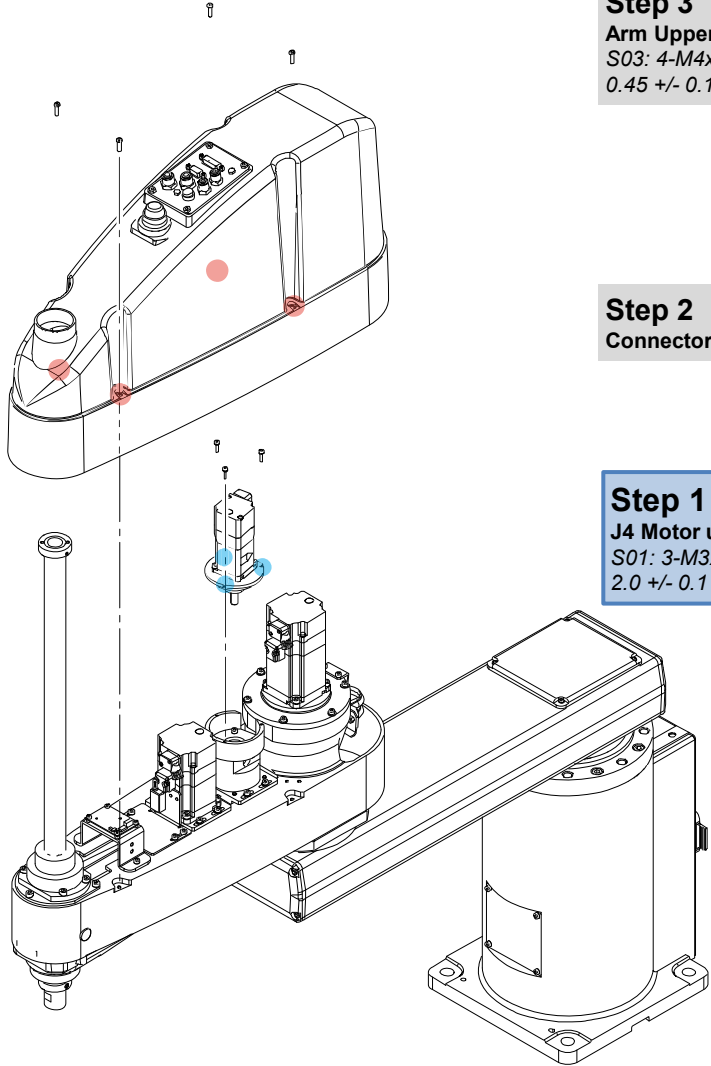

**Step 3**  
**Arm Upper Cover**  
 S03: 4-M4x15  
 0.45 +/- 0.1 N·m

**Step 2**  
**Connectors and cables**

**Step 1**  
**J4 Motor unit**  
 S01: 3-M3x12  
 2.0 +/- 0.1 N·m

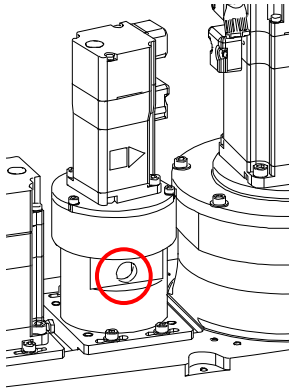
3. Rotate the J4 Reduction Gear two or three turns while moving the belt or shaft from the output side.
  4. Remove the cover of the hole for securing the extension shaft, and tighten the bolt to secure the extension shaft to the Reduction Gear.
- 

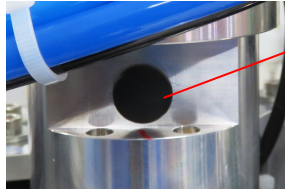
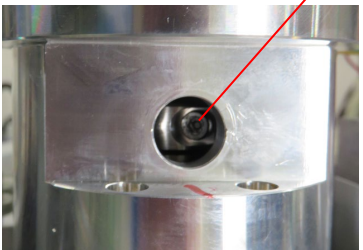

5. Tighten the bolts of the Motor Plate and motor that were temporarily secured to secure the J4 Motor unit to the Reduction Gear.

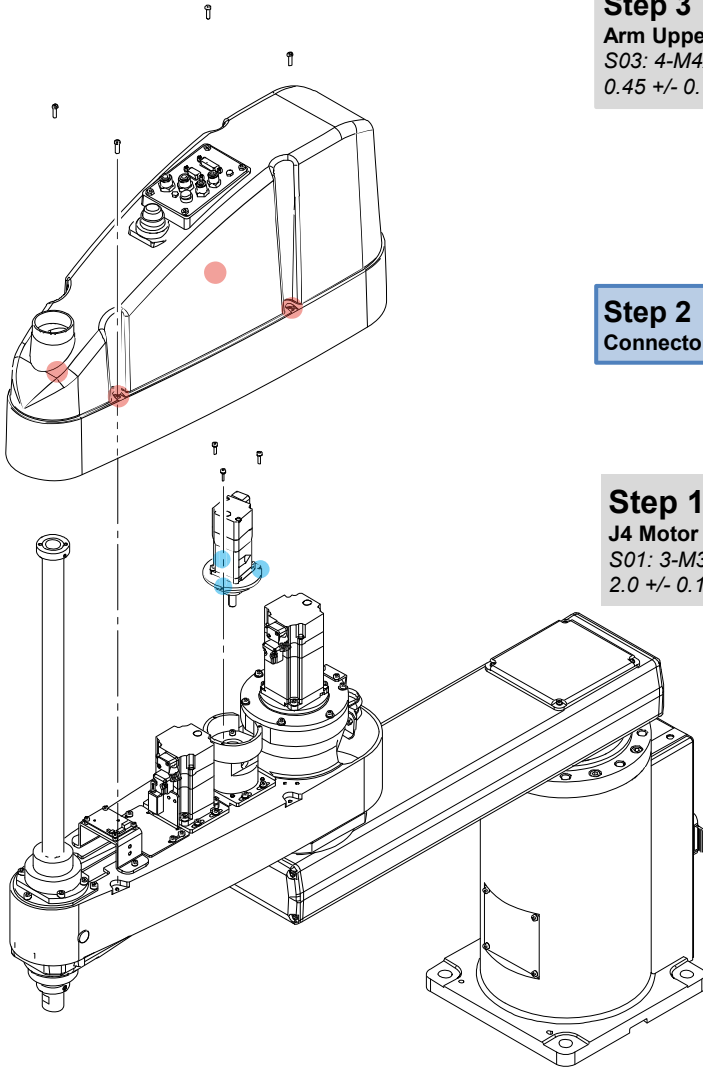

## 2.5.2 Installing the J4 Motor Unit



**Step 3**  
**Arm Upper Cover**  
 S03: 4-M4x15  
 0.45 +/- 0.1 N·m

**Step 2**  
**Connectors and cables**

**Step 1**  
**J4 Motor unit**  
 S01: 3-M3x12  
 2.0 +/- 0.1 N·m

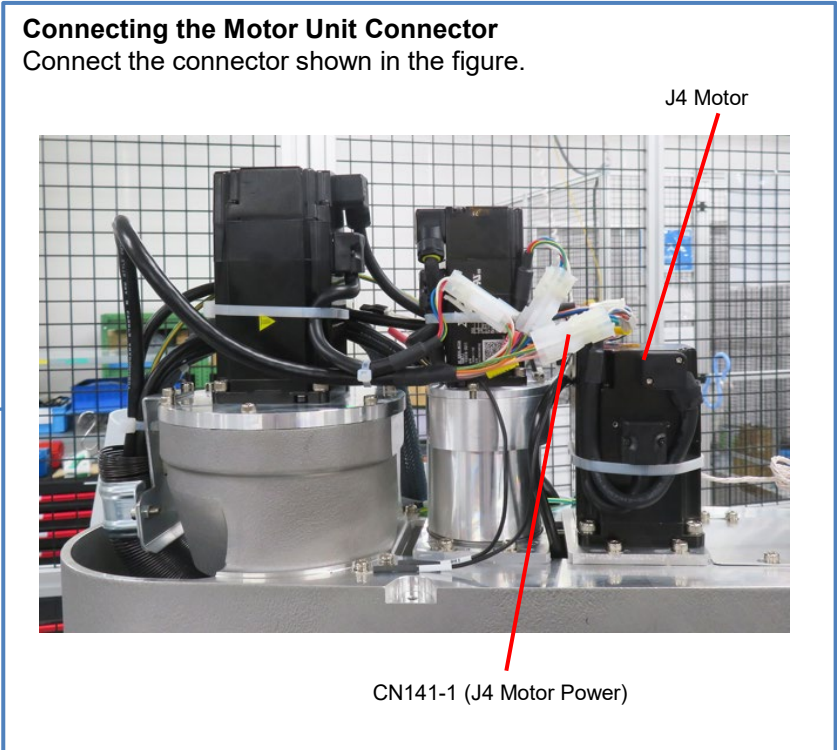

## 2.5.2 Installing the J4 Motor Unit

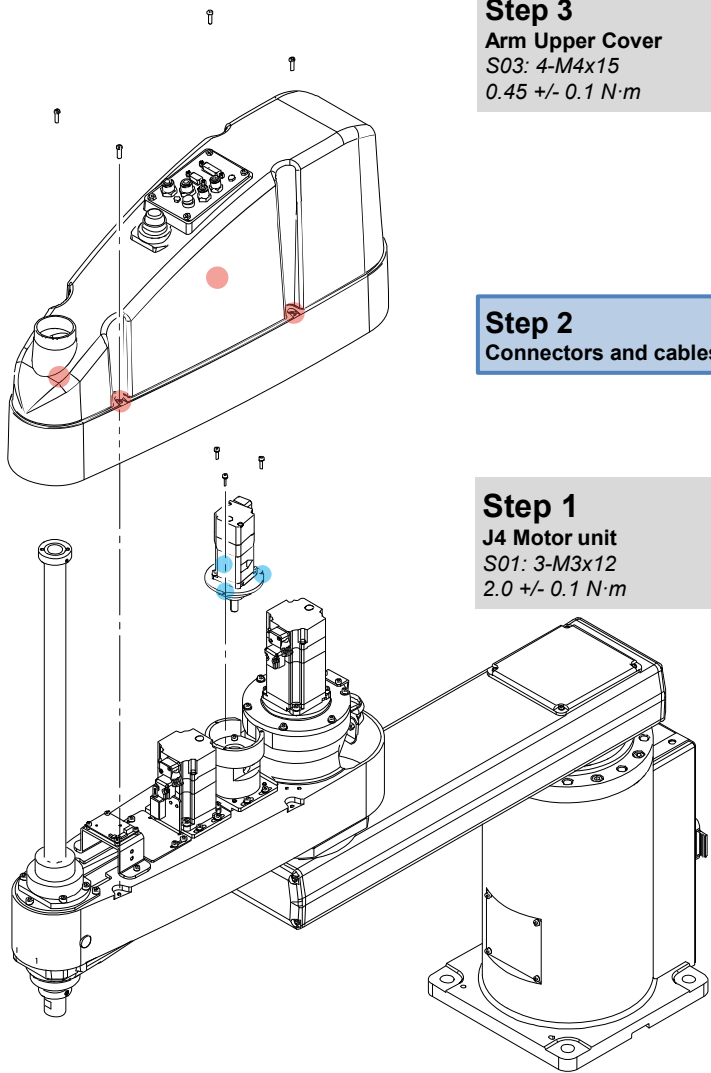

**Step 3**  
**Arm Upper Cover**  
 S03: 4-M4x15  
 0.45 +/- 0.1 N·m

**Step 2**  
**Connectors and cables**

**Step 1**  
**J4 Motor unit**  
 S01: 3-M3x12  
 2.0 +/- 0.1 N·m

**Connecting the Motor Unit Connectors**  
 Wrap CN341-1 with the Silicone Sheet together with the other connectors and cables, and secure them with a wire tie (AB150).

**CAUTION**  
 Take care not to apply a load to the cables, for example, by bending the cables with excessive force.

CN341-1 (J4 Motor Signal)  
 CN440-1 (J4 Brake)  
 Silicone Sheet, Wire tie (AB150)

J4 Motor

Tie the connectors shown in the figure.

CN341-1 (J4 Motor Signal)

CN3G0-2 (Control Board Cable)

## 2.5.2 Installing the J4 Motor Unit

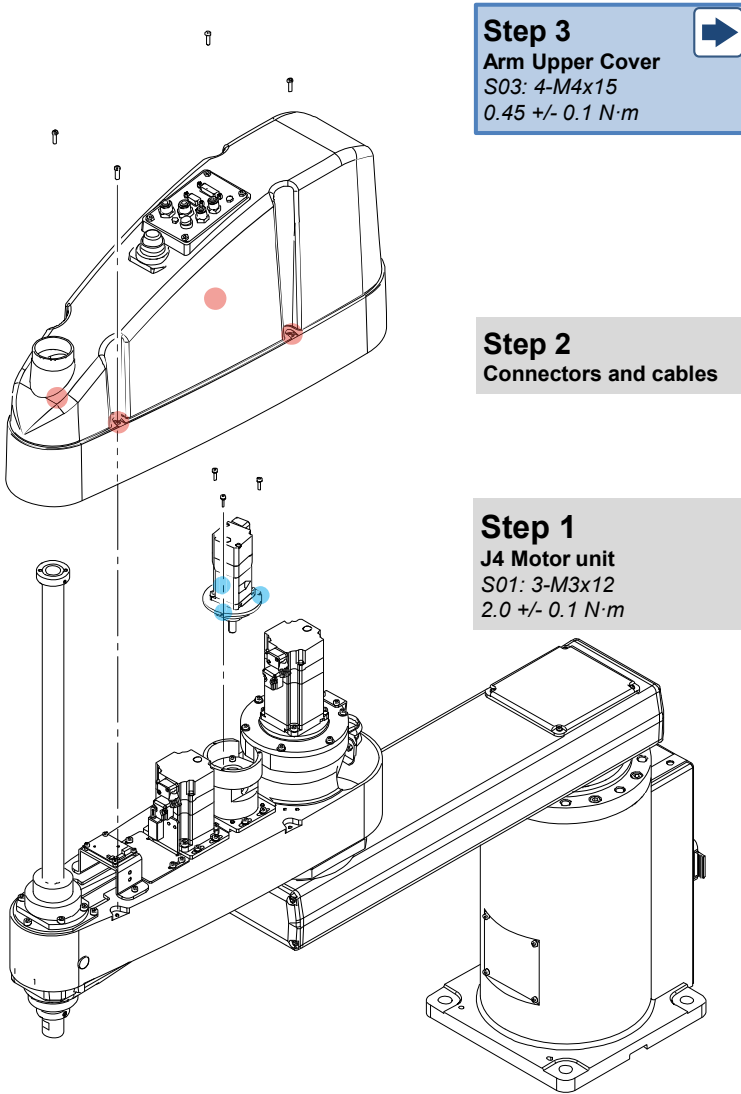

**Step 3**  
 Arm Upper Cover  
 S03: 4-M4x15  
 0.45 +/- 0.1 N·m

**Step 2**  
 Connectors and cables

**Step 1**  
 J4 Motor unit  
 S01: 3-M3x12  
 2.0 +/- 0.1 N·m

**CAUTION**  
 After performing the maintenance procedure, perform calibration of Joint #4.  
[3.1 Calibration](#)

## 2.5.3 Replacing the J4 Motor Unit/Brake

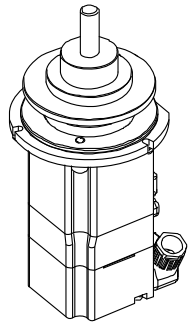

J4 Motor unit/Brake

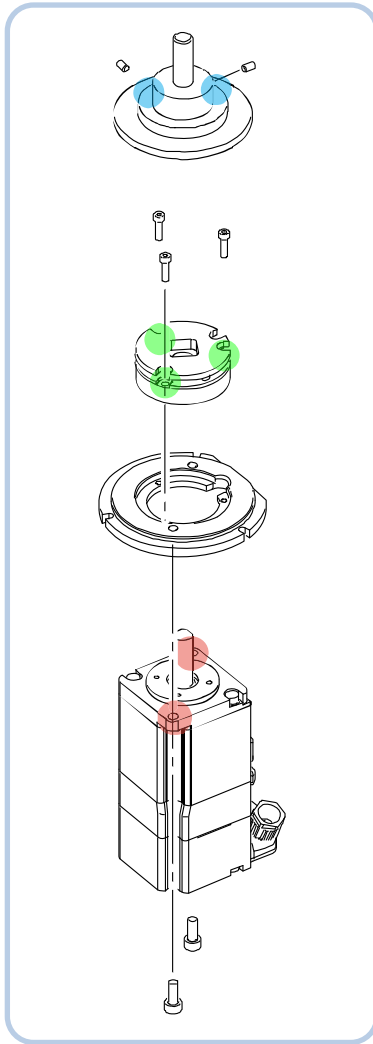

### Step 1

**Extension shaft**  
S05: 2-M3x5  
0.7 +/- 0.1 N·m

### Step 2

**Brake**  
S01: 3-M2.5x10  
1.0 +/- 0.1 N·m

### Step 3

**Motor Plate**  
S01: 2-M4x10  
4.0 +/- 0.2 N·m

### Installing the Extension Shaft

#### CAUTION

- Insert the extension shaft until it contacts the end face of the motor shaft and secure it in place.
- As shown in the figure, secure the extension shaft with screws so that they are aligned with the D-Cuts on the motor shaft.
- Align the hub of the extension shaft with the Brake disk.

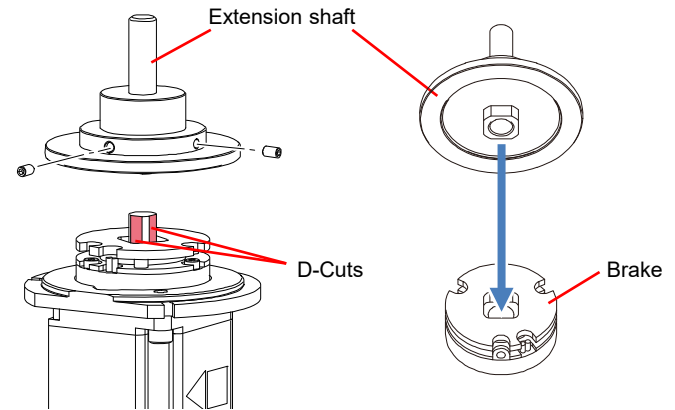

\* The disassembly procedure is described here.  
Perform assembly by following the disassembly procedure in the reverse order.

## 2.5.3 Replacing the J4 Motor Unit/Brake

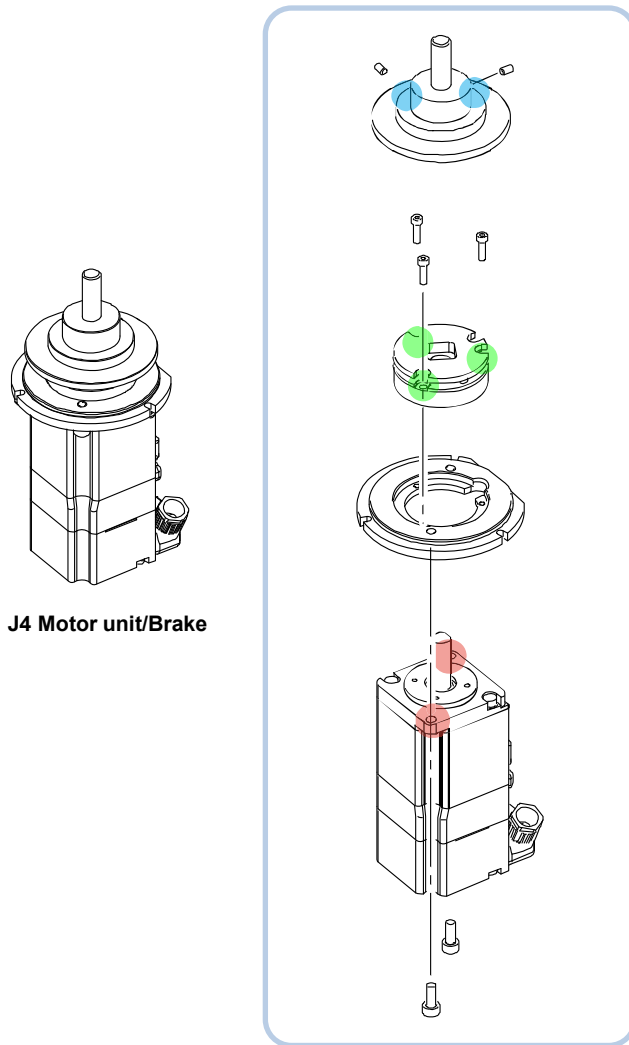

J4 Motor unit/Brake

**Step 1**  
**Extension shaft**  
 S05: 2-M3x5  
 0.7 +/- 0.1 N·m

**Step 2**  
**Brake**  
 S01: 3-M2.5x10  
 1.0 +/- 0.1 N·m

**Step 3**  
**Motor Plate**  
 S01: 2-M4x10  
 4.0 +/- 0.2 N·m

### Installing the Brake

#### CAUTION

Install the Brake to the Motor Plate according to the orientation shown in the figure.

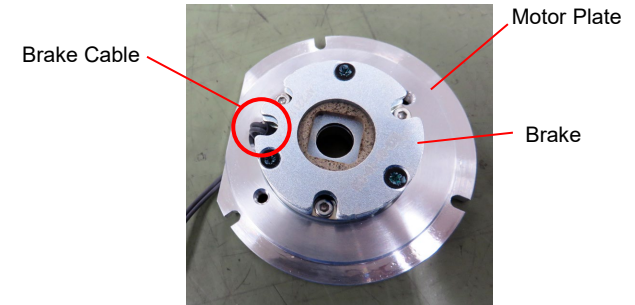

#### POINT

Pass the Brake cable to the motor plate as shown in the figure.



#### Note

When the Brake disk is out of position, align the hole position with the center by the following procedure.

1. Connect the BR4 connector.
2. Press the Brake Release Switch to release the Brake.
3. Turn OFF the Controller.
4. Align the hole position with the center by hand.

\* The disassembly procedure is described here.  
 Perform assembly by following the disassembly procedure in the reverse order.

### 2.5.3 Replacing the J4 Motor Unit/Brake

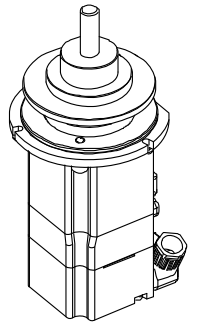

J4 Motor unit/Brake

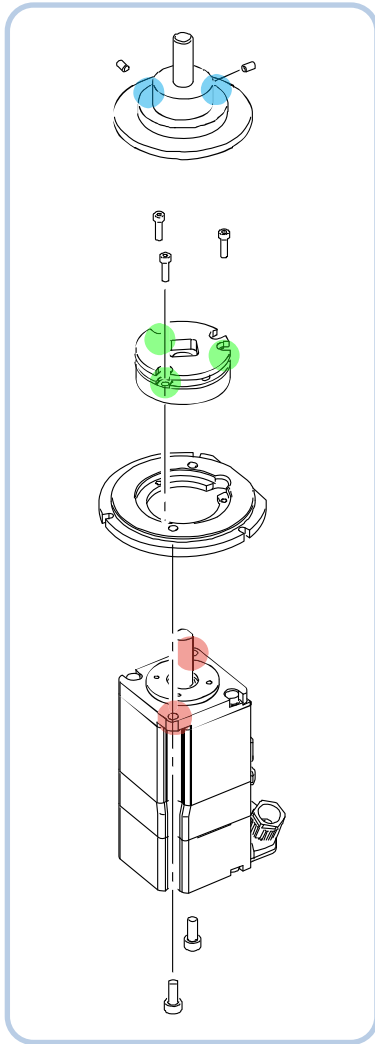

**Step 1**  
**Extension shaft**  
 S05: 2-M3x5  
 0.7 +/- 0.1 N·m

**Step 2**  
**Brake**  
 S01: 3-M2.5x10  
 1.0 +/- 0.1 N·m

**Step 3**  
**Motor Plate**  
 S01: 2-M4x10  
 4.0 +/- 0.2 N·m

#### Installing the Motor Plate

**CAUTION**

Attach the J4 Motor and the Motor Plate according to the orientation shown in the figure. If the attachment method is incorrect, it will not be possible to connect the motor cables to the connectors, and the motor cables may come in contact with surrounding parts.

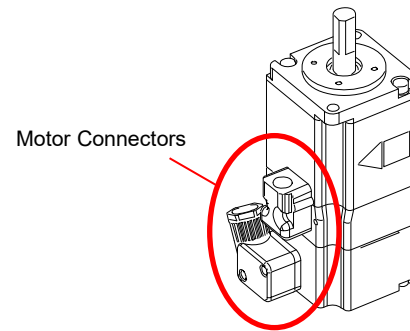
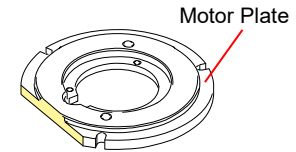

\* The disassembly procedure is described here.  
 Perform assembly by following the disassembly procedure in the reverse order.



## 2.5.4 Removing the Timing Belt (U)

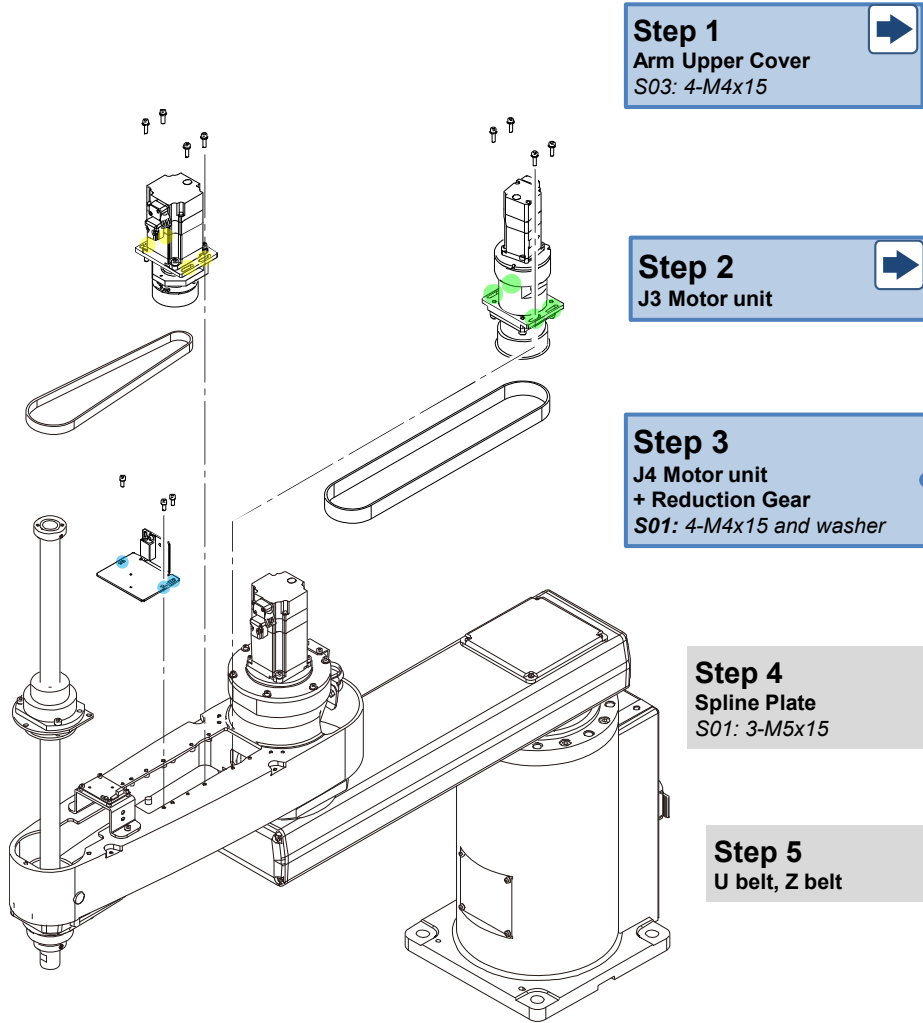

**Step 1**  
 Arm Upper Cover  
 S03: 4-M4x15

**Step 2**  
 J3 Motor unit

**Step 3**  
 J4 Motor unit  
 + Reduction Gear  
 S01: 4-M4x15 and washer

**Step 4**  
 Spline Plate  
 S01: 3-M5x15

**Step 5**  
 U belt, Z belt

**CAUTION**  
 The Ball Screw Spline Unit may fall while performing maintenance. Before performing maintenance, lower it to the lower limit.

**Disconnecting the Connectors**  
 Disconnect the connectors shown in the figure.



CN341-1 (J4 Motor Signal)  
 CN440-1 (J4 Brake)  
 Silicone Sheet  
 Wire tie (AB150)

CN141-1  
 (J4 Motor Power)

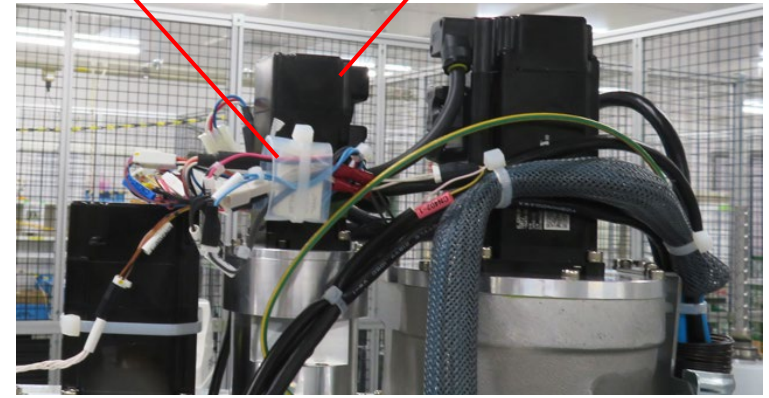

## 2.5.4 Removing the Timing Belt (U)

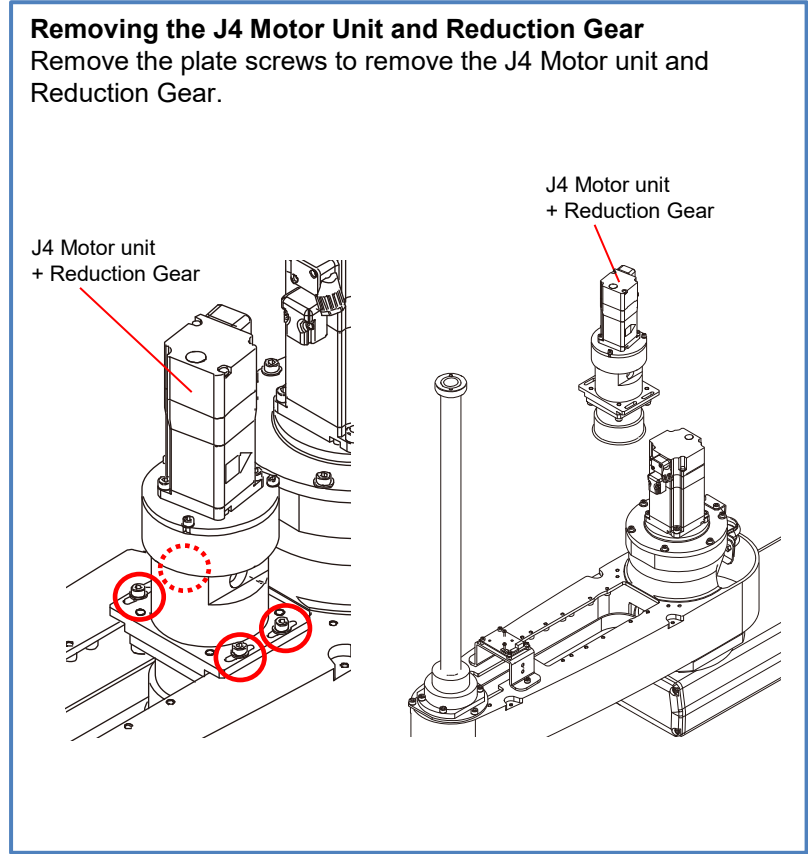
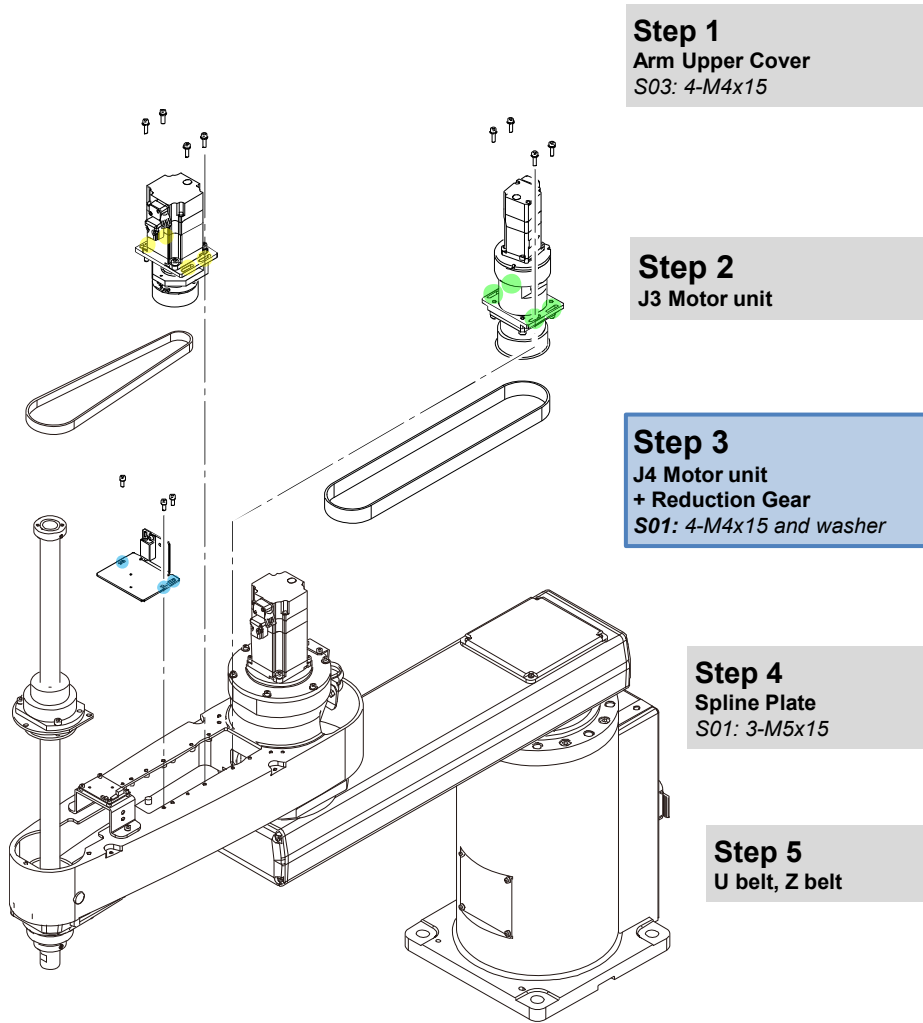



## 2.5.4 Removing the Timing Belt (U)

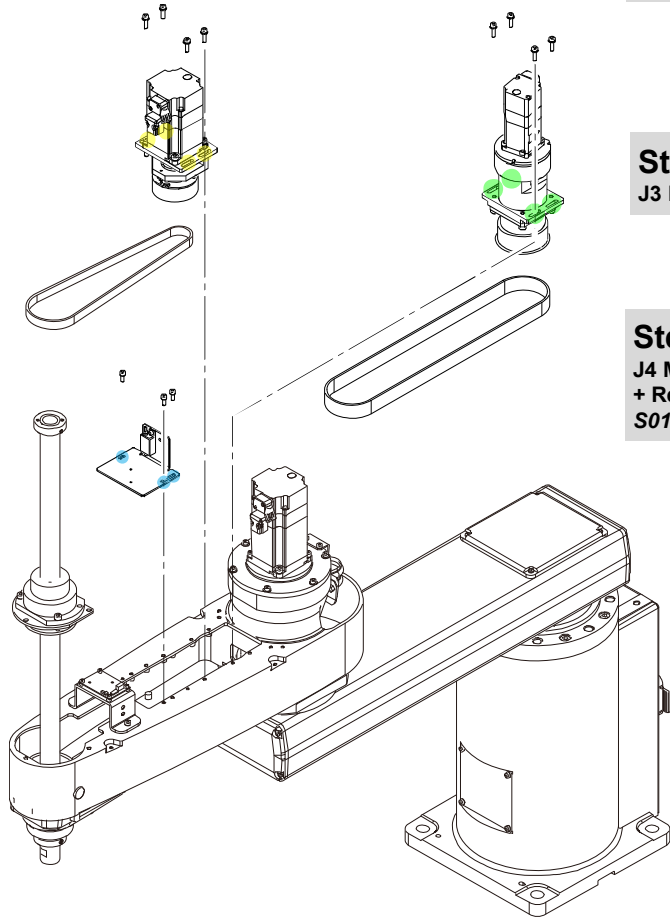

**Step 1**  
 Arm Upper Cover  
 S03: 4-M4x15

**Step 2**  
 J3 Motor unit

**Step 3**  
 J4 Motor unit  
 + Reduction Gear  
 S01: 4-M4x15 and washer

**Step 4**  
 Spline Plate  
 S01: 3-M5x15

**Step 5**  
 U belt, Z belt

**POINT**  
 Remove the bolts securing the Spline Plate.

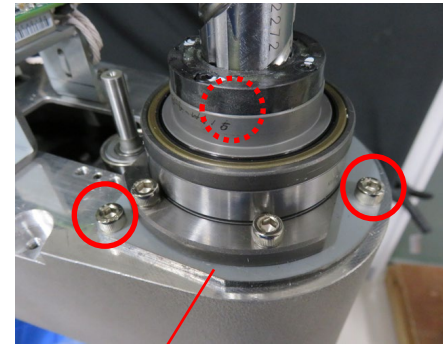

Spline Plate

**POINT**  
 Lift up the Spline Plate, and draw the Z belt and U belt upwards from the shaft.

## 2.5.5 Installing the Timing Belt (U)

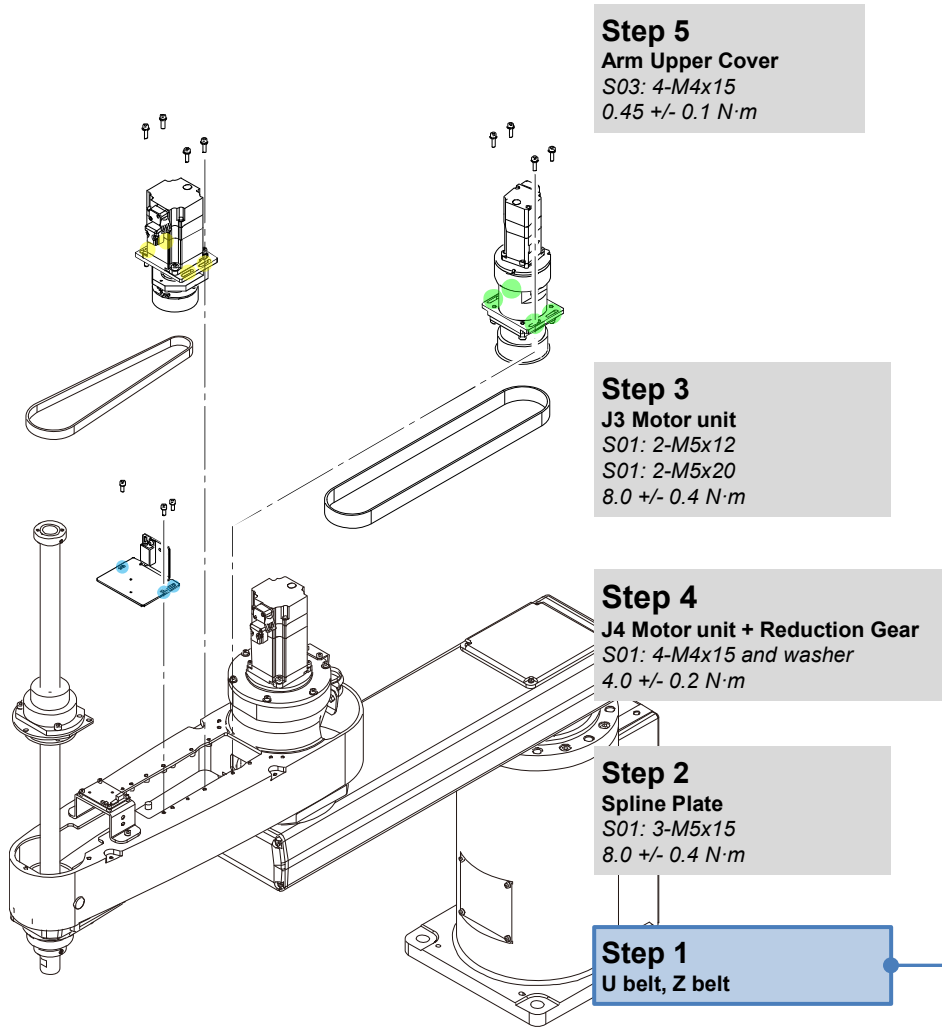

**POINT**

Lift up the Spline Plate, and place the Z belt and U belt onto the pulley.

As shown in the figure, place the belt on the Ball Screw Spline Unit.

**CAUTION**

Make sure that the teeth of the belt and pulley are properly engaged.

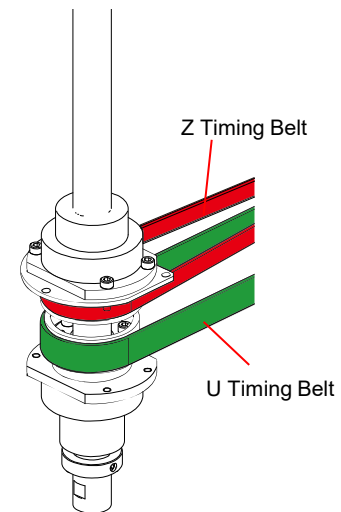

## 2.5.5 Installing the Timing Belt (U)

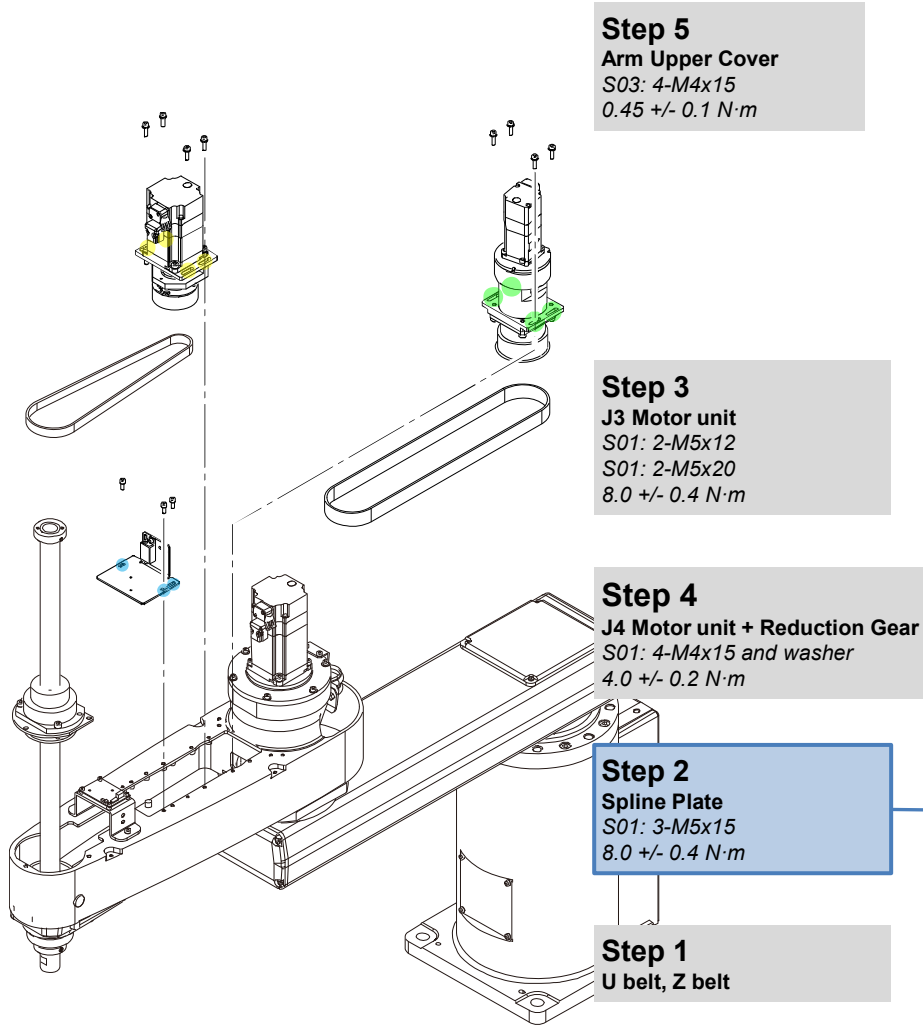

### POINT

Temporarily secure the Spline Plate on Arm2.

Arm top surface

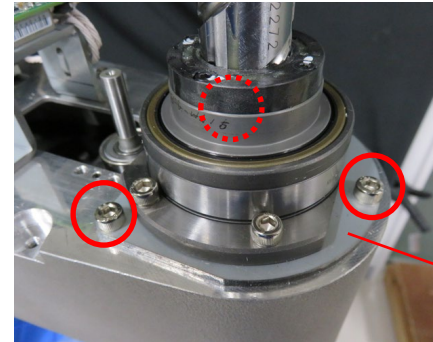

Spline Plate

S01: 3-M5x15

### CAUTION

Take care to prevent the Timing Belt from being caught between the nut and Arm2.

After temporary tightening, perform centering. Move the Ball Screw Spline Unit up and down. The Ball Screw Spline Unit will be positioned to the center of the arm.

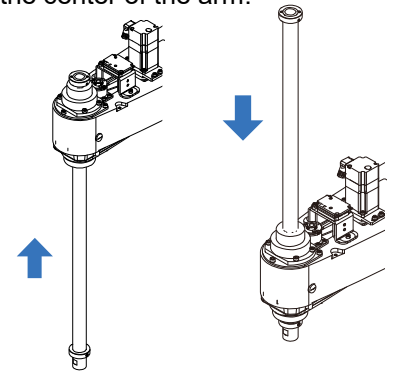

### CAUTION

After performing centering, fix the Spline Plate.

## 2.5.5 Installing the Timing Belt (U)

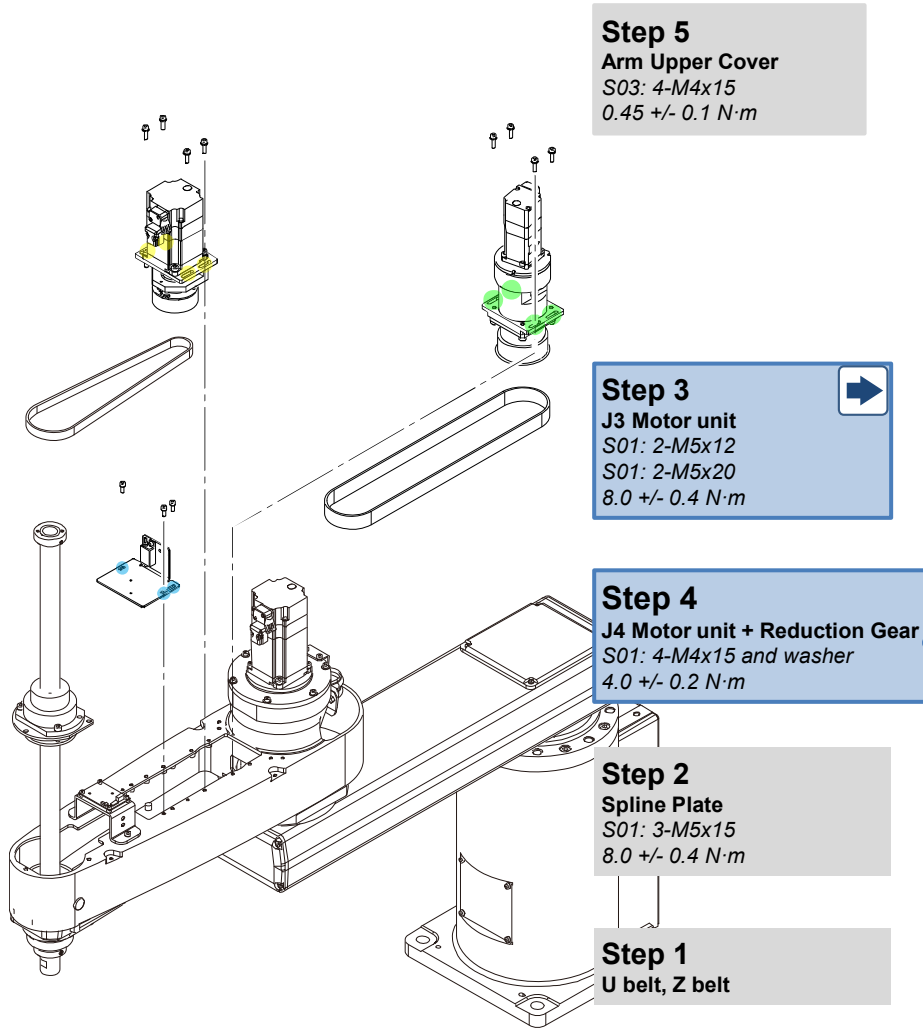

### Connecting the Connectors

Connect the connectors shown in the figure.



## 2.5.5 Installing the Timing Belt (U)

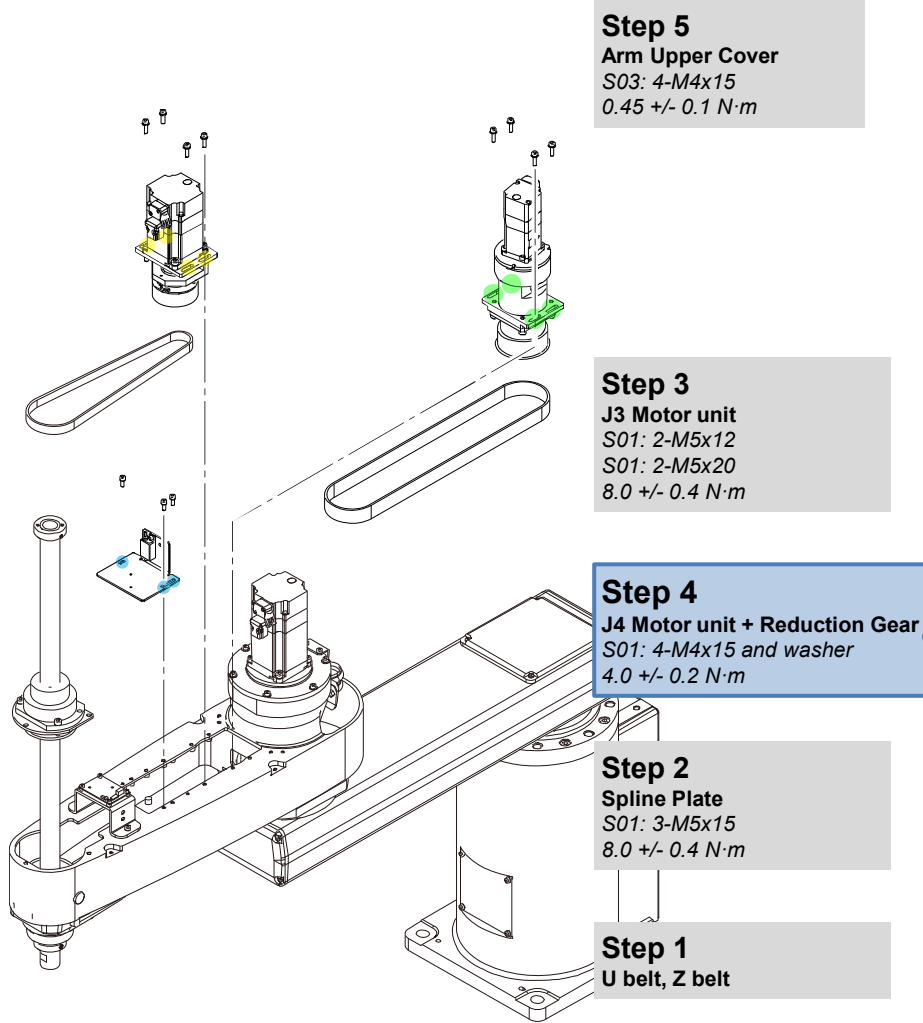

**Step 5**  
**Arm Upper Cover**  
 S03: 4-M4x15  
 0.45 +/- 0.1 N·m

**Step 3**  
**J3 Motor unit**  
 S01: 2-M5x12  
 S01: 2-M5x20  
 8.0 +/- 0.4 N·m

**Step 4**  
**J4 Motor unit + Reduction Gear**  
 S01: 4-M4x15 and washer  
 4.0 +/- 0.2 N·m

**Step 2**  
**Spline Plate**  
 S01: 3-M5x15  
 8.0 +/- 0.4 N·m

**Step 1**  
**U belt, Z belt**

**Connecting the Motor Unit Connectors**  
 Wrap CN341-1 with the Silicone Sheet together with the other connectors and cables, and secure them with a wire tie (AB150).  
**CAUTION**  
 Take care not to apply a load to the cables, for example, by bending the cables with excessive force.

CN341-1 (J4 Motor Signal)  
 CN440-1 (J4 Brake)  
 Silicone Sheet, Wire tie (AB150)

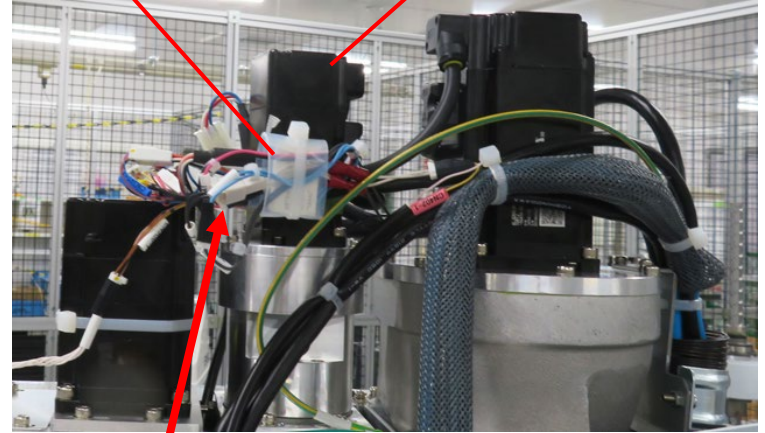

Tie the connectors shown in the figure.

CN341-1 (J4 Motor Signal)  
 CN3G0-2 (Control Board Cable)

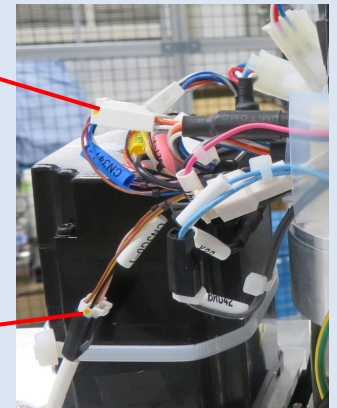



## 2.5.5 Installing the Timing Belt (U)

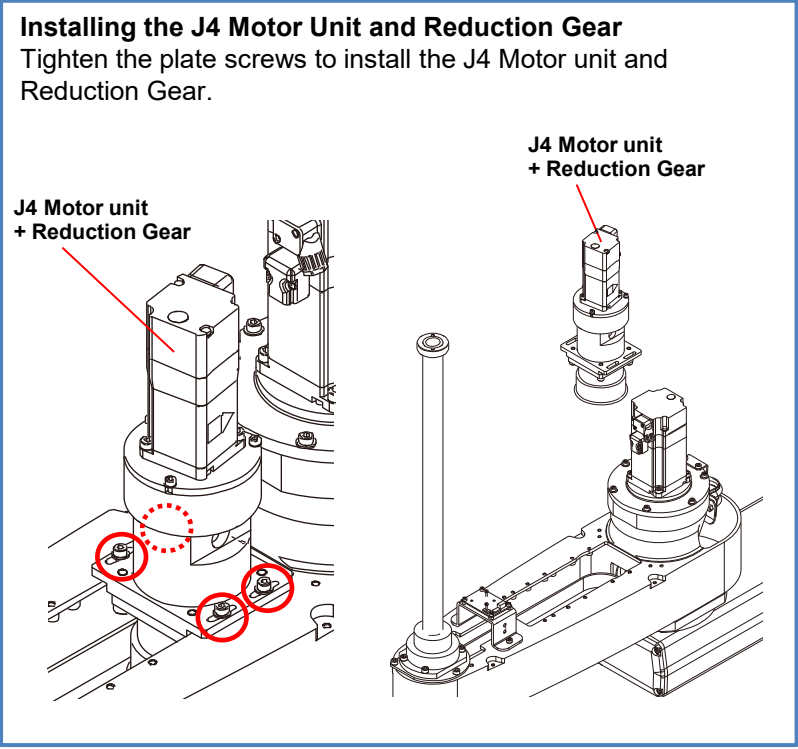
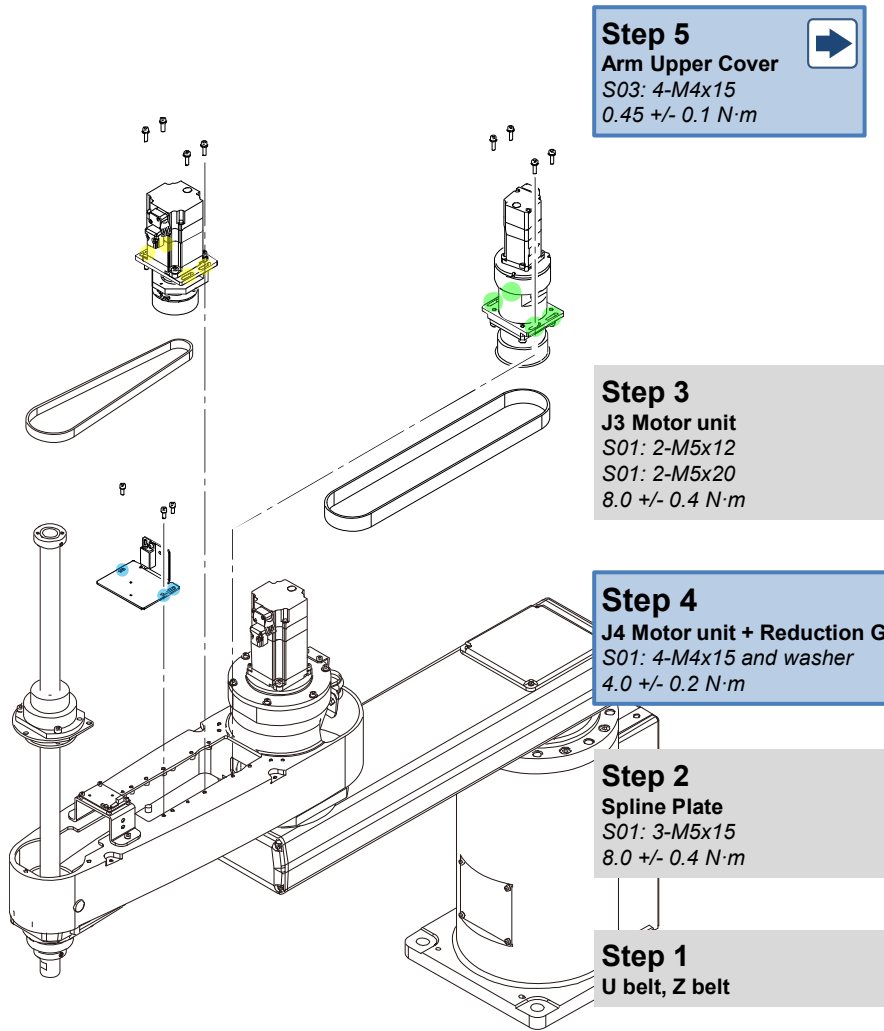

**CAUTION**  
After performing the maintenance procedure, perform calibration of Joint #3 and Joint #4.  
[3.1 Calibration](#)

## 2.5.6 Removing the J4 Reduction Gear

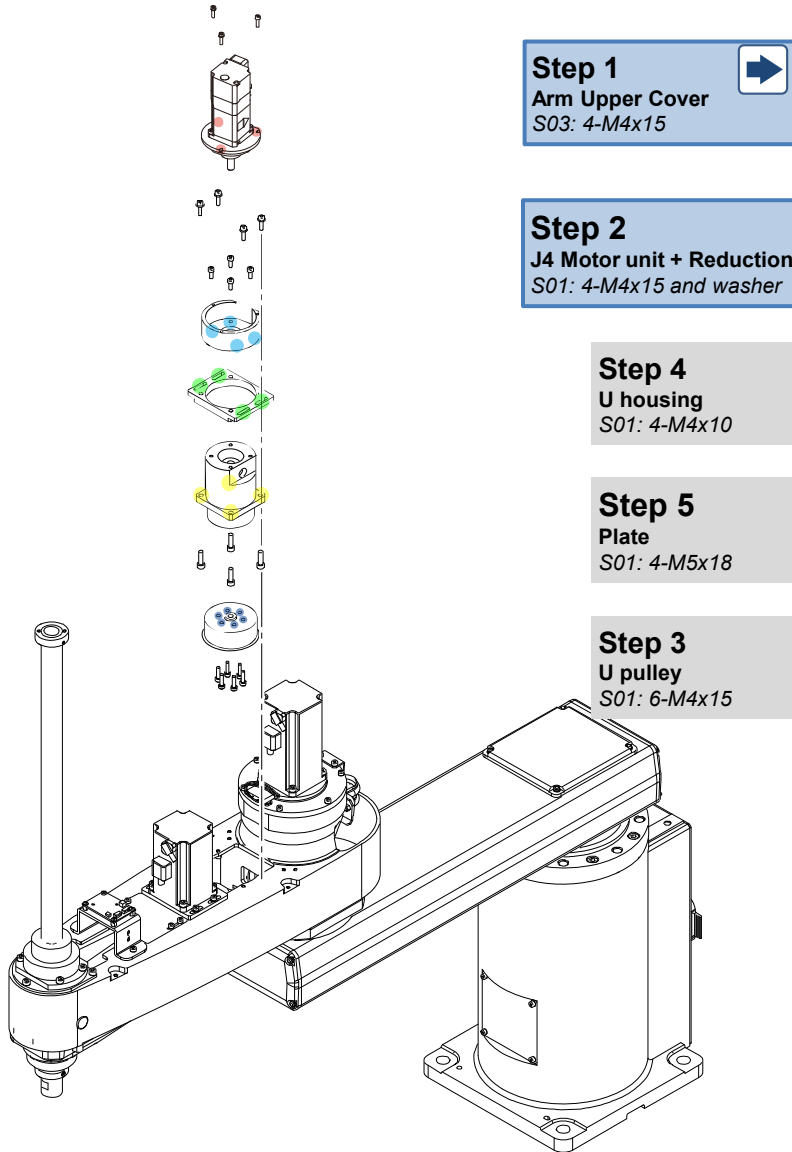

### Disconnecting the Connectors

Disconnect the connectors shown in the figure.

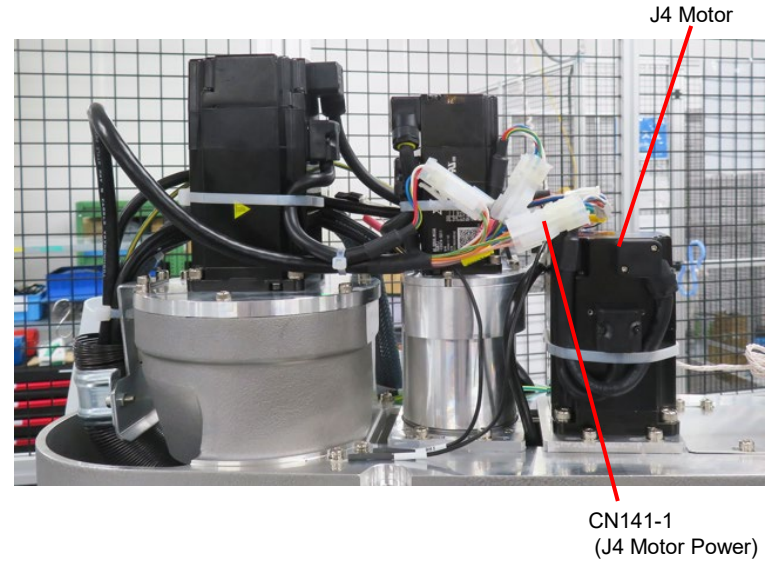

CN341-1 (J4 Motor Signal)  
CN440-1 (J4 Brake)  
Silicone Sheet  
Wire tie (AB150)

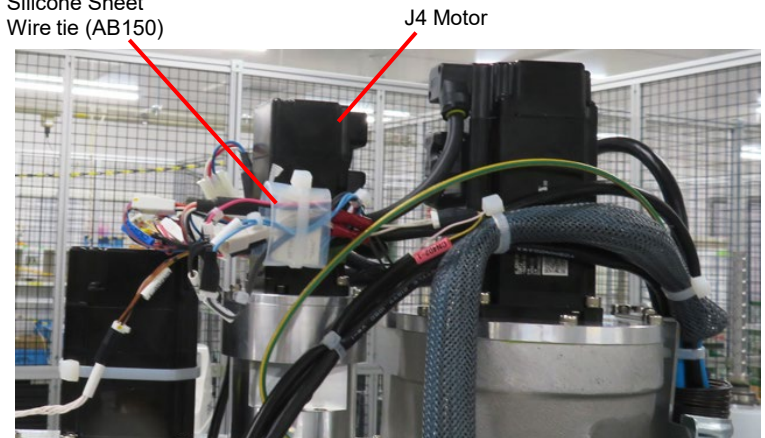



## 2.5.6 Removing the J4 Reduction Gear

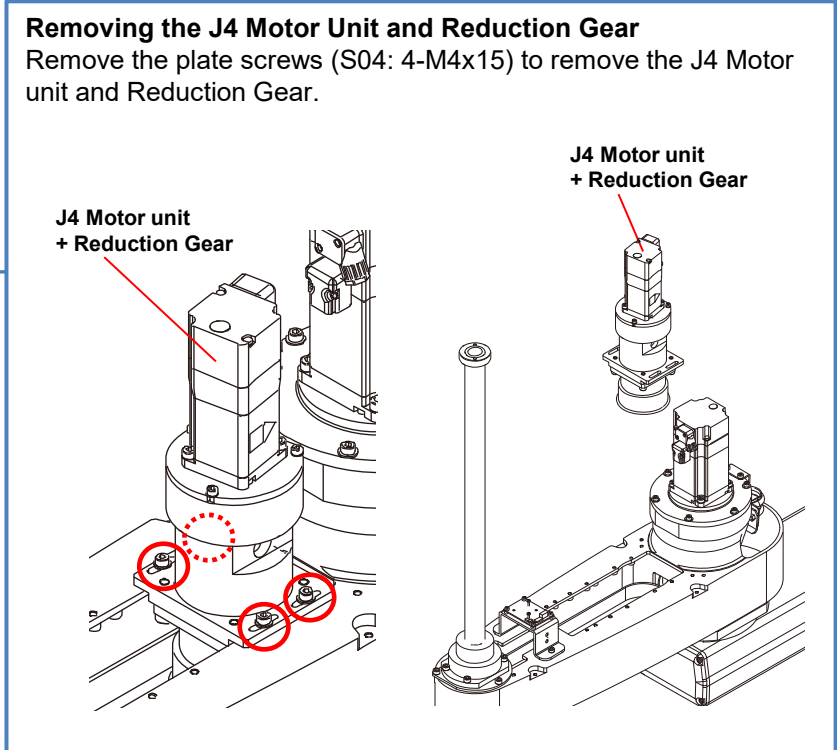
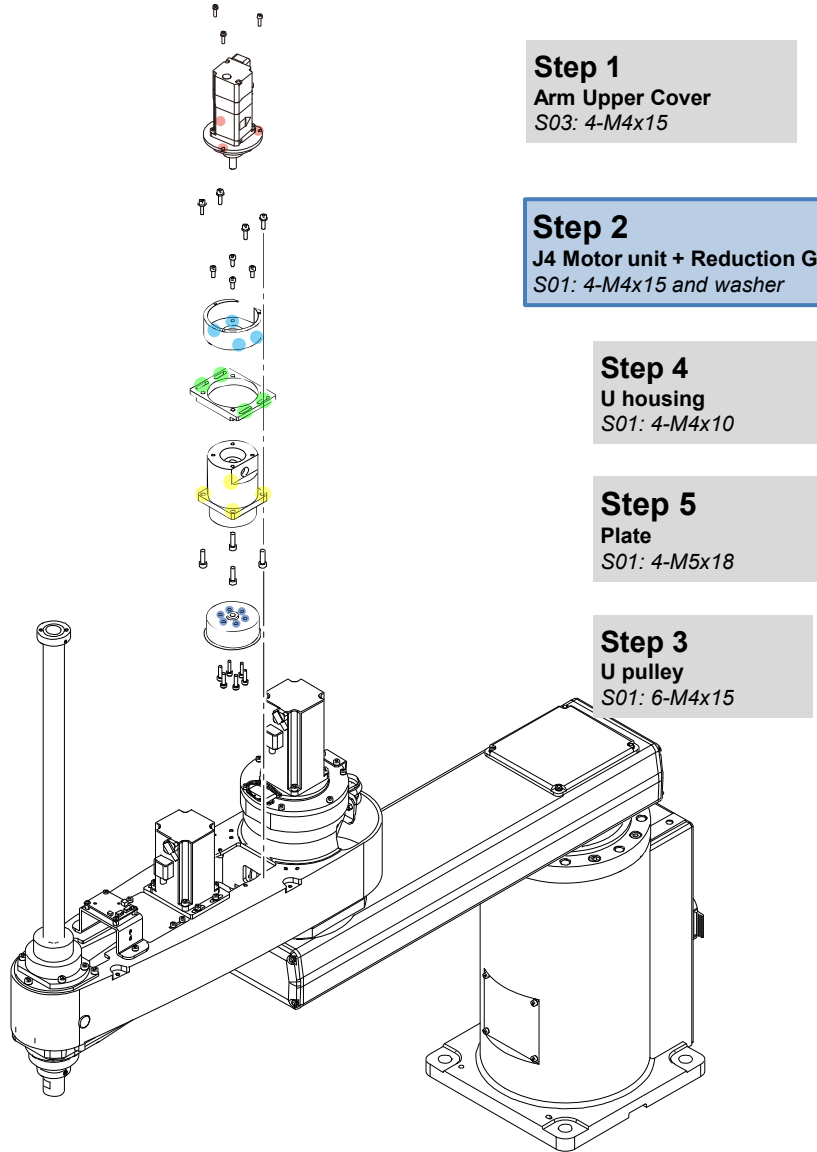

## 2.5.6 Removing the J4 Reduction Gear

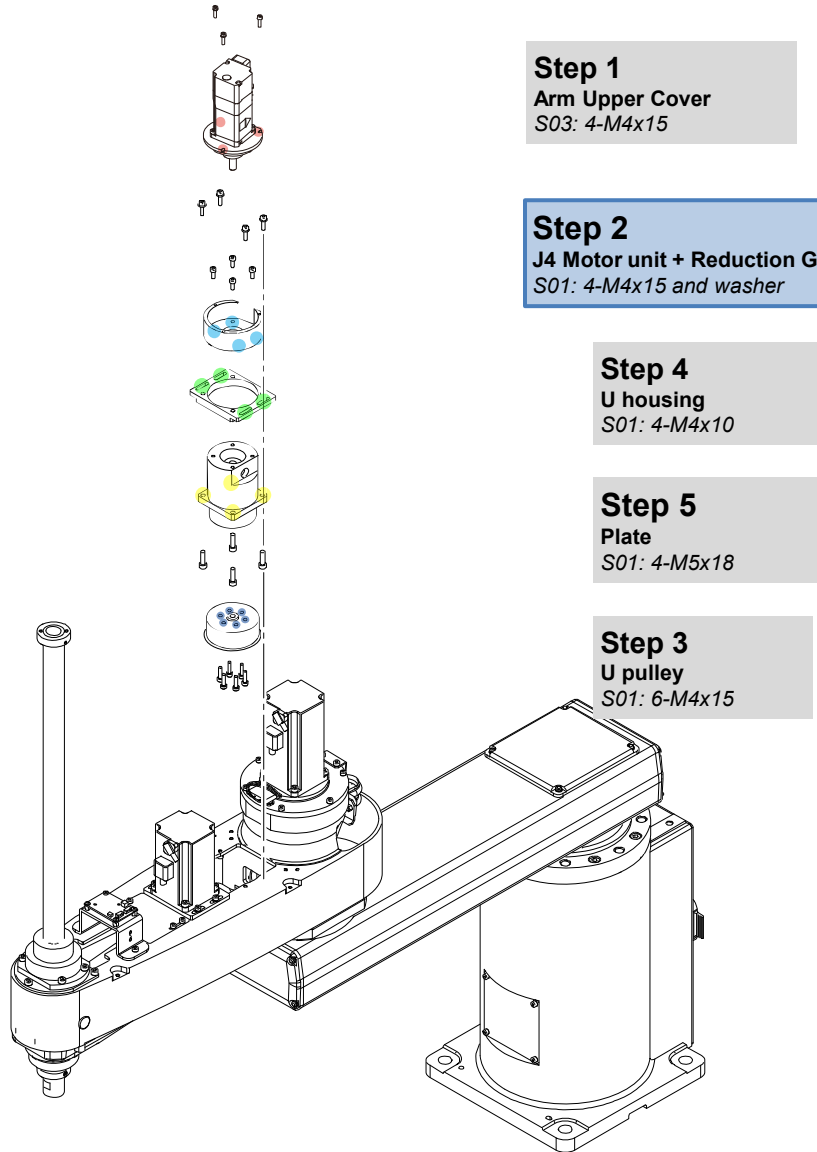

### Removing the J4 Motor Unit

Remove the J4 Motor unit from the Reduction Gear.

1. Remove the screws shown in the figure.  
S01: 3-M3x12

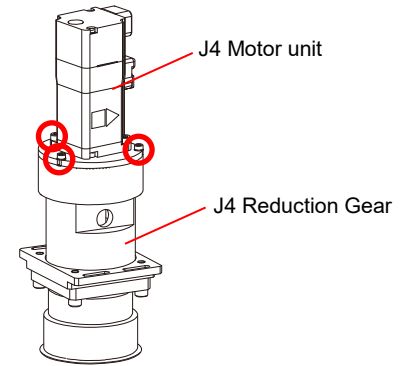

2. Remove the cover shown in the figure, and loosen the screws securing the extension shaft.

#### POINT

When the screw position is not aligned, turn the motor body slightly to bring the screw position into alignment.

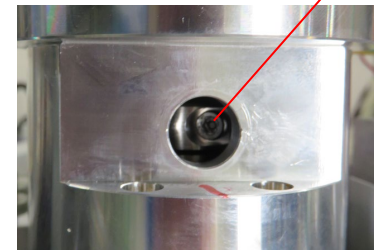
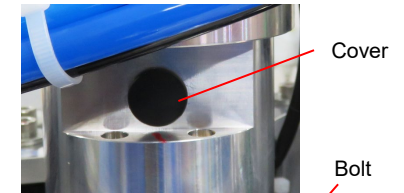
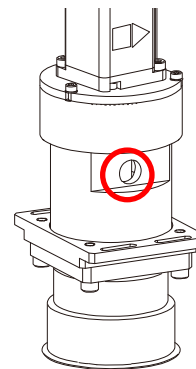

3. Remove the J4 Motor unit from the Reduction Gear.

## 2.5.6 Removing the J4 Reduction Gear

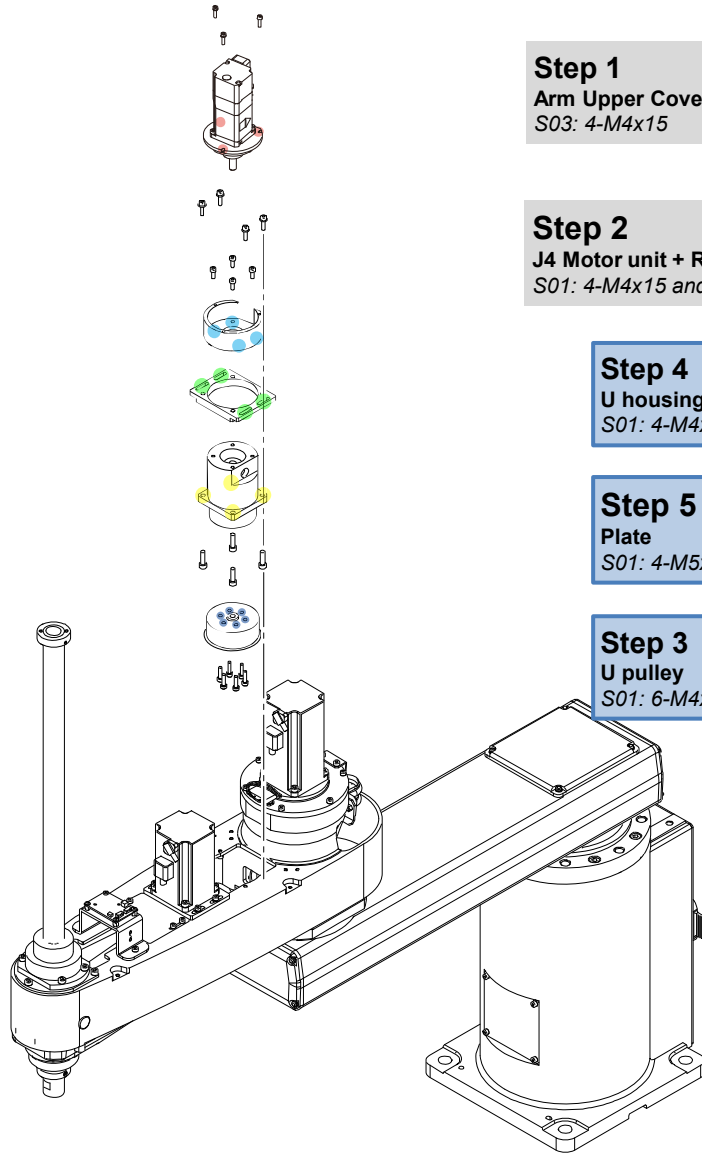

**Step 1**  
**Arm Upper Cover**  
 S03: 4-M4x15

**Step 2**  
**J4 Motor unit + Reduction Gear**  
 S01: 4-M4x15 and washer

**Step 4**  
**U housing**  
 S01: 4-M4x10

**Step 5**  
**Plate**  
 S01: 4-M5x18

**Step 3**  
**U pulley**  
 S01: 6-M4x15

Loosen the screws shown in the figure, and remove the U housing from the Reduction Gear Unit.

U housing

Loosen the screws shown in the figure, and remove the plate from the Reduction Gear Unit.

Plate

Loosen the bolts shown in the figure, and remove the U pulley from the Reduction Gear Unit.

U pulley

## 2.5.7 Installing the J4 Reduction Gear

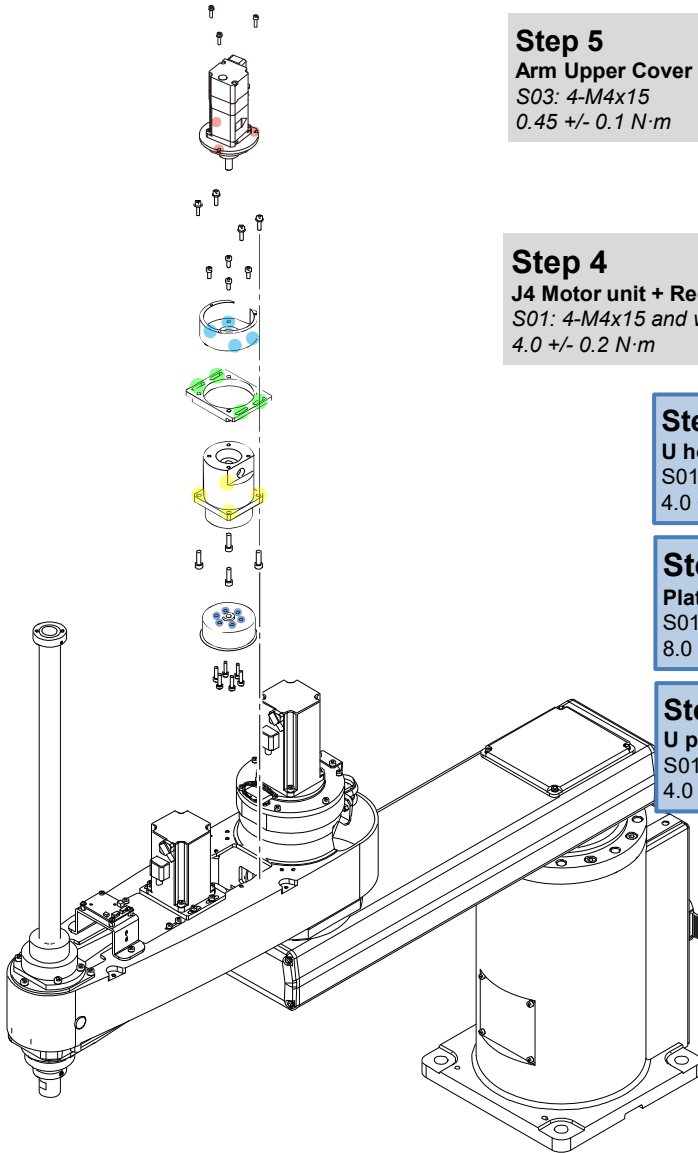

**Step 5**  
**Arm Upper Cover**  
 S03: 4-M4x15  
 0.45 +/- 0.1 N·m

**Step 4**  
**J4 Motor unit + Reduction Gear**  
 S01: 4-M4x15 and washer  
 4.0 +/- 0.2 N·m

**Step 2**  
**U housing**  
 S01: 4-M4x10  
 4.0 +/- 0.2 N·m

**Step 1**  
**Plate**  
 S01: 4-M5x18  
 8.0 +/- 0.4 N·m

**Step 3**  
**U pulley**  
 S01: 6-M4x15  
 4.0 +/- 0.2 N·m

Secure the U housing to the Reduction Gear according to the orientation shown in the figure.

U housing

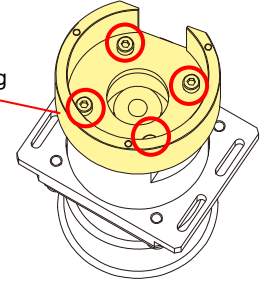

Secure the Reduction Gear to the plate according to the orientation shown in the figure.

Plate

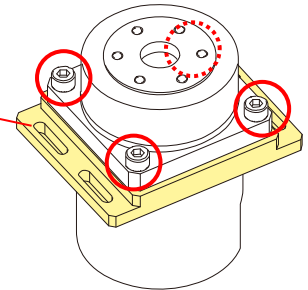

Tighten the bolts shown in the figure, and secure the U pulley to the Reduction Gear.

U pulley

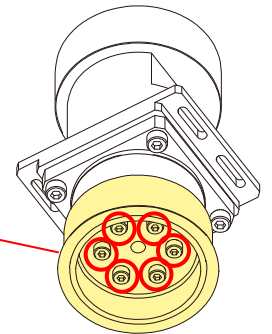

## 2.5.7 Installing the J4 Reduction Gear

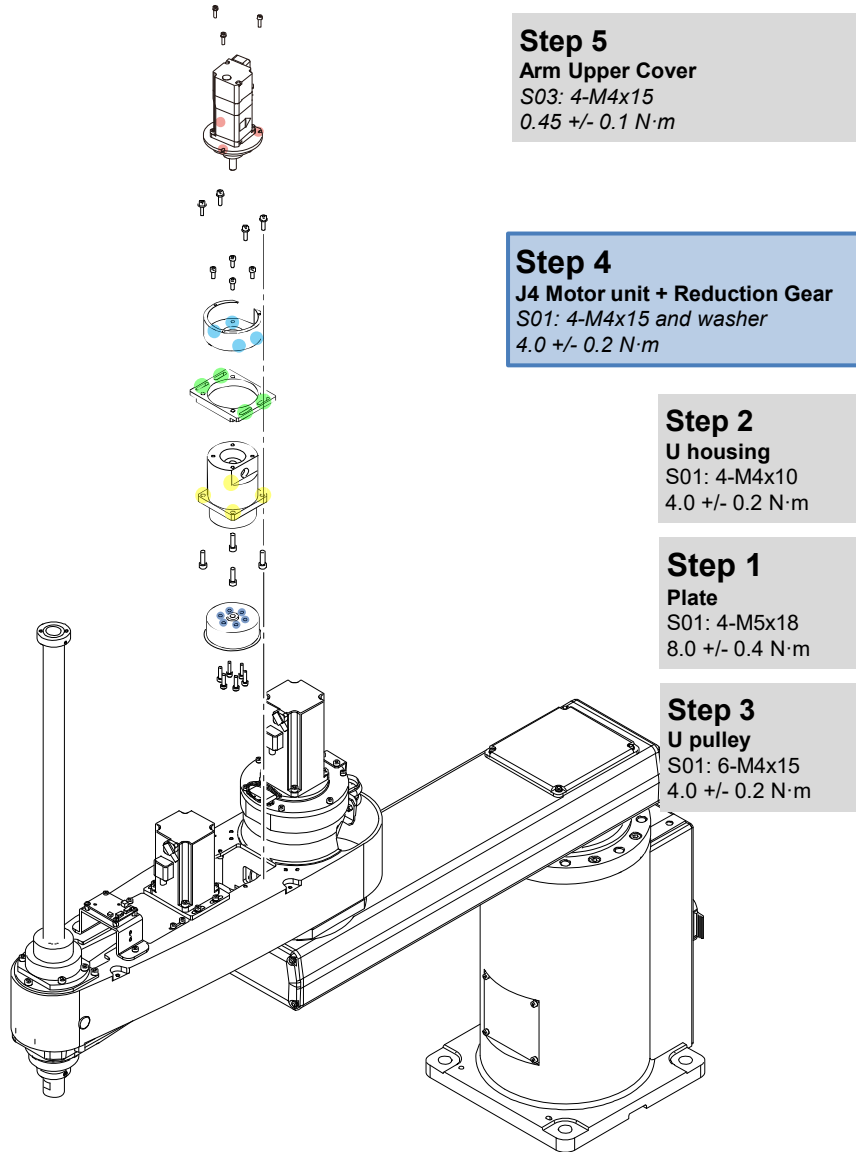

### Installing the J4 Motor Unit

Install the J4 Motor unit to the Reduction Gear.

1. Insert the extension shaft of the J4 Motor unit into the Reduction Gear.

**POINT**

Insert the extension shaft according to the orientation shown in the figure.

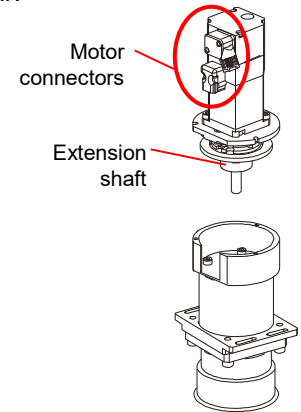

2. Temporarily secure the Motor Plate to the U housing with bolts (M3x12), and loosen the motor securing bolts (M4x70) to temporarily secure the motor.

**POINT**

As a rule, temporarily fasten to the extent that the motor unit can be moved by hand and does not tilt over.

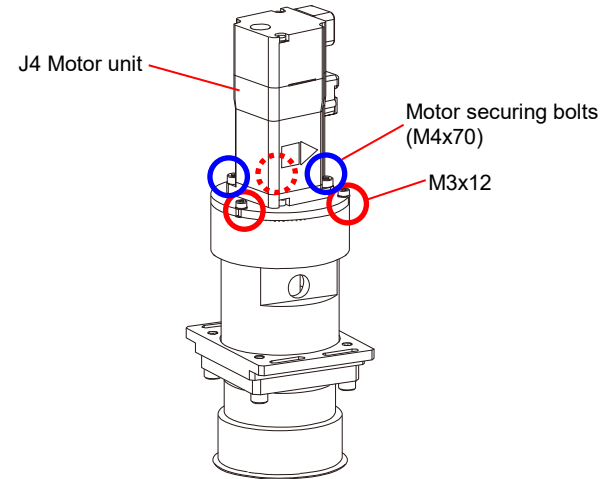

## 2.5.7 Installing the J4 Reduction Gear

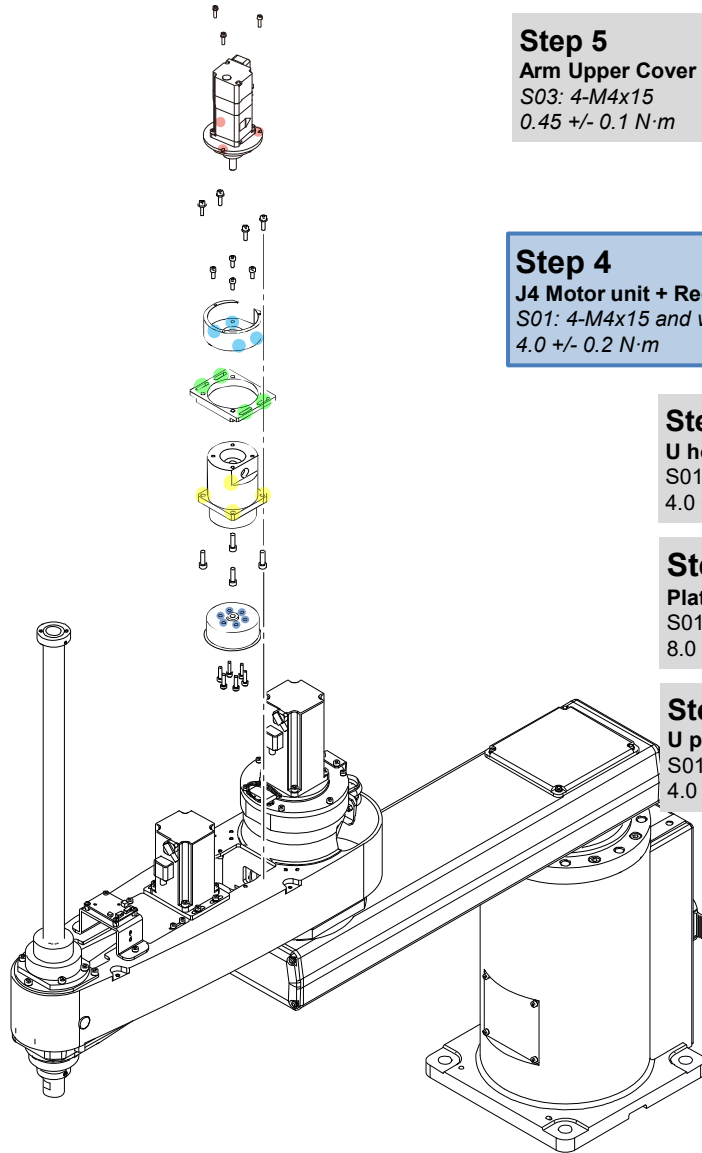

**Step 5**  
**Arm Upper Cover**  
 S03: 4-M4x15  
 0.45 +/- 0.1 N·m

**Step 4**  
**J4 Motor unit + Reduction Gear**  
 S01: 4-M4x15 and washer  
 4.0 +/- 0.2 N·m

**Step 2**  
**U housing**  
 S01: 4-M4x10  
 4.0 +/- 0.2 N·m

**Step 1**  
**Plate**  
 S01: 4-M5x18  
 8.0 +/- 0.4 N·m

**Step 3**  
**U pulley**  
 S01: 6-M4x15  
 4.0 +/- 0.2 N·m

3. Rotate the J4 Reduction Gear two or three turns from the output side.
4. Remove the cover of the hole for securing the extension shaft, and turn the bolt to secure the extension shaft to the Reduction Gear.  
 After securing, attach the cover.

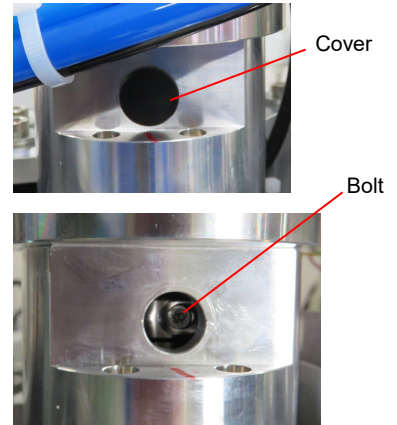
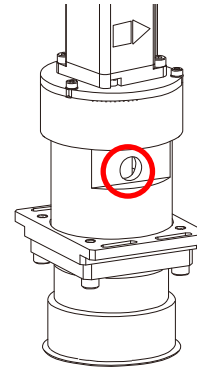

5. Tighten the bolts of the Motor Plate and motor that were temporarily secured to secure the J4 Motor unit to the Reduction Gear.

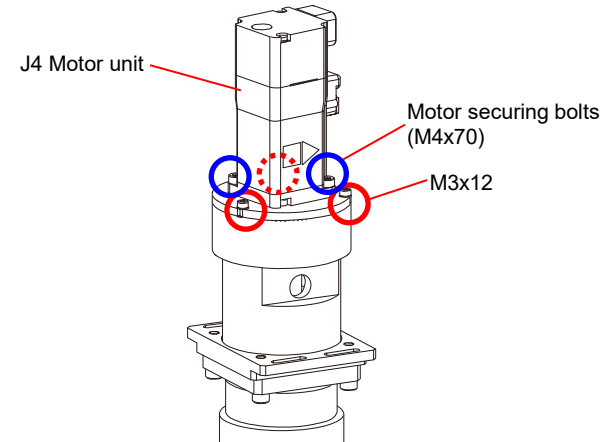

## 2.5.7 Installing the J4 Reduction Gear

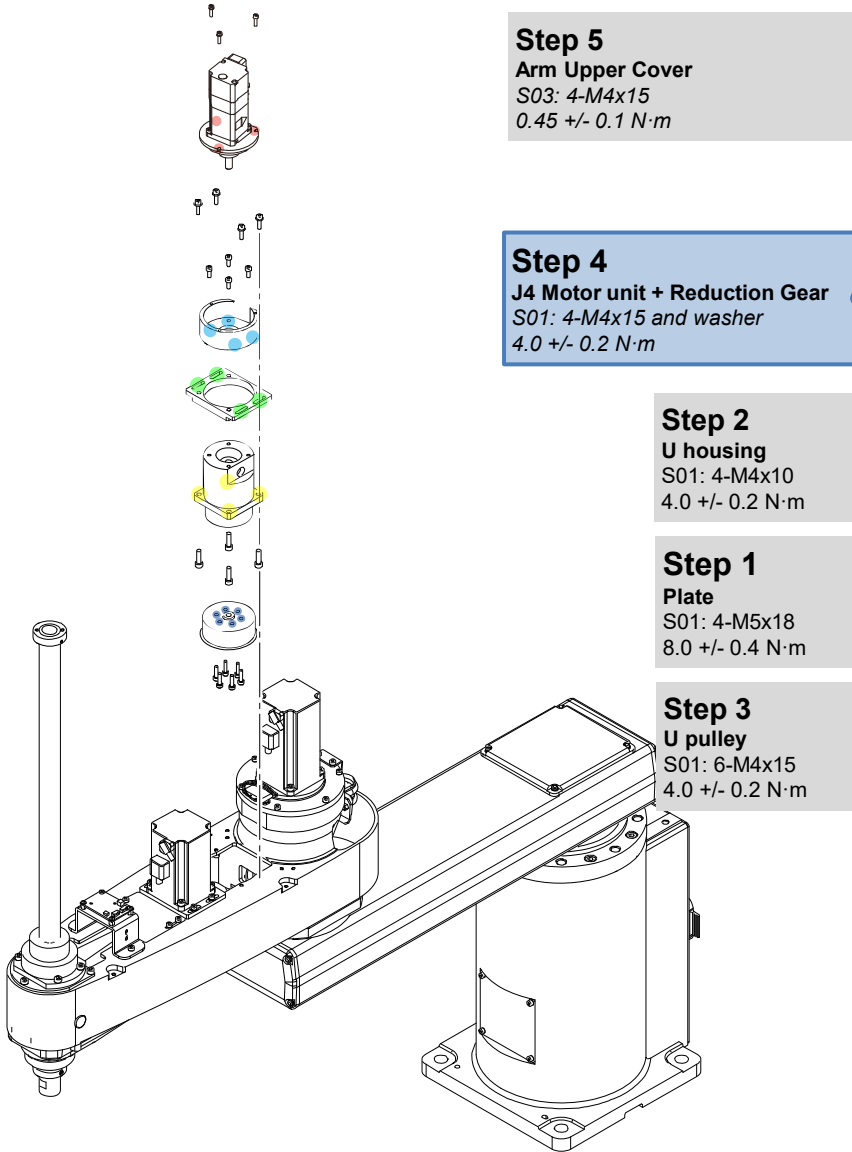

**Step 5**  
**Arm Upper Cover**  
 S03: 4-M4x15  
 0.45 +/- 0.1 N·m

**Step 4**  
**J4 Motor unit + Reduction Gear**  
 S01: 4-M4x15 and washer  
 4.0 +/- 0.2 N·m

**Step 2**  
**U housing**  
 S01: 4-M4x10  
 4.0 +/- 0.2 N·m

**Step 1**  
**Plate**  
 S01: 4-M5x18  
 8.0 +/- 0.4 N·m

**Step 3**  
**U pulley**  
 S01: 6-M4x15  
 4.0 +/- 0.2 N·m

6. Place the U belt on the U pulley.

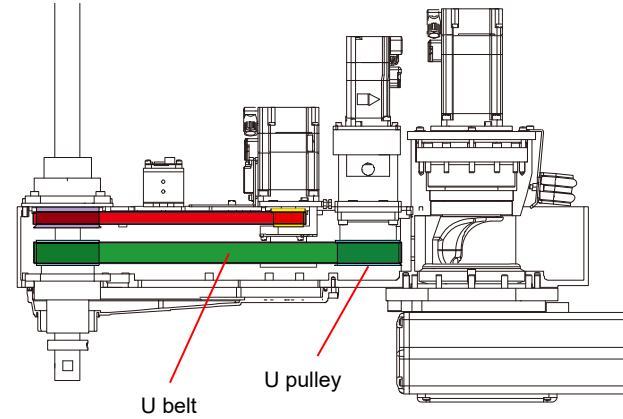

7. Secure the J4 Motor unit and Reduction Gear to the arm.  
 S01: 4-M4x15  
 4.0 +/- 0.2 N·m

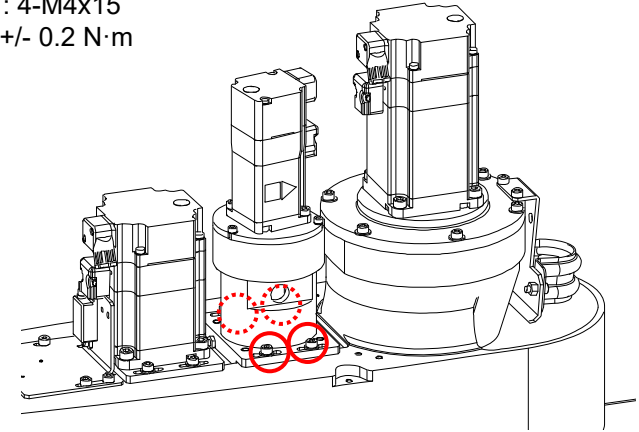



## 2.5.7 Installing the J4 Reduction Gear

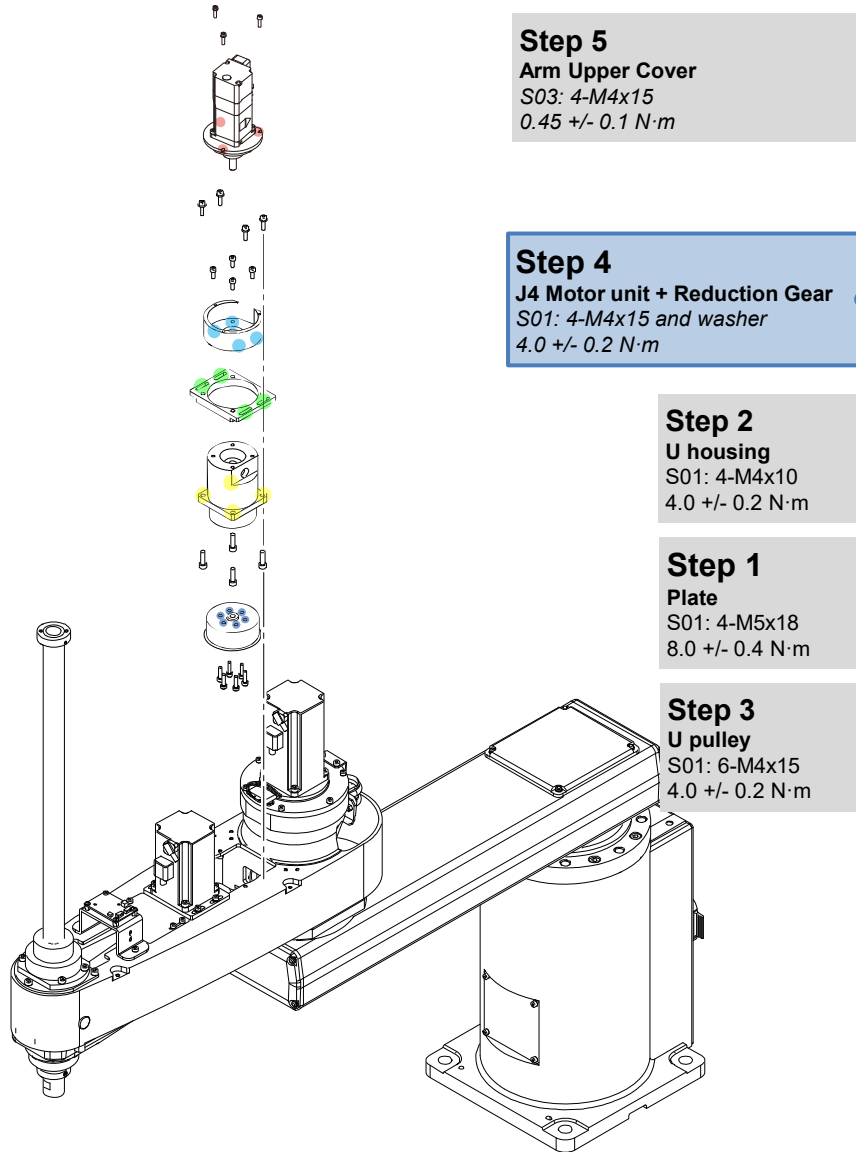

**Step 5**  
**Arm Upper Cover**  
 S03: 4-M4x15  
 0.45 +/- 0.1 N·m

**Step 4**  
**J4 Motor unit + Reduction Gear**  
 S01: 4-M4x15 and washer  
 4.0 +/- 0.2 N·m

**Step 2**  
**U housing**  
 S01: 4-M4x10  
 4.0 +/- 0.2 N·m

**Step 1**  
**Plate**  
 S01: 4-M5x18  
 8.0 +/- 0.4 N·m

**Step 3**  
**U pulley**  
 S01: 6-M4x15  
 4.0 +/- 0.2 N·m

**CAUTION**

If the Timing Belt is placed on the flange, correct tension will not be obtained during belt tension adjustment.

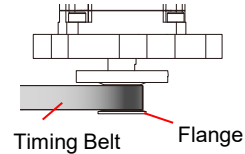

Set the belt so that it is level with respect to the pulley without it being placed on the flange.

**POINT**

Temporarily tighten the motor unit fixing bolts until the motor unit can slide freely to adjust the belt tension.

**Belt tension adjustment**

Adjust the belt tension after installing the motor unit.

[3.2 Adjusting the Timing Belt Tension](#)

## 2.5.7 Installing the J4 Reduction Gear

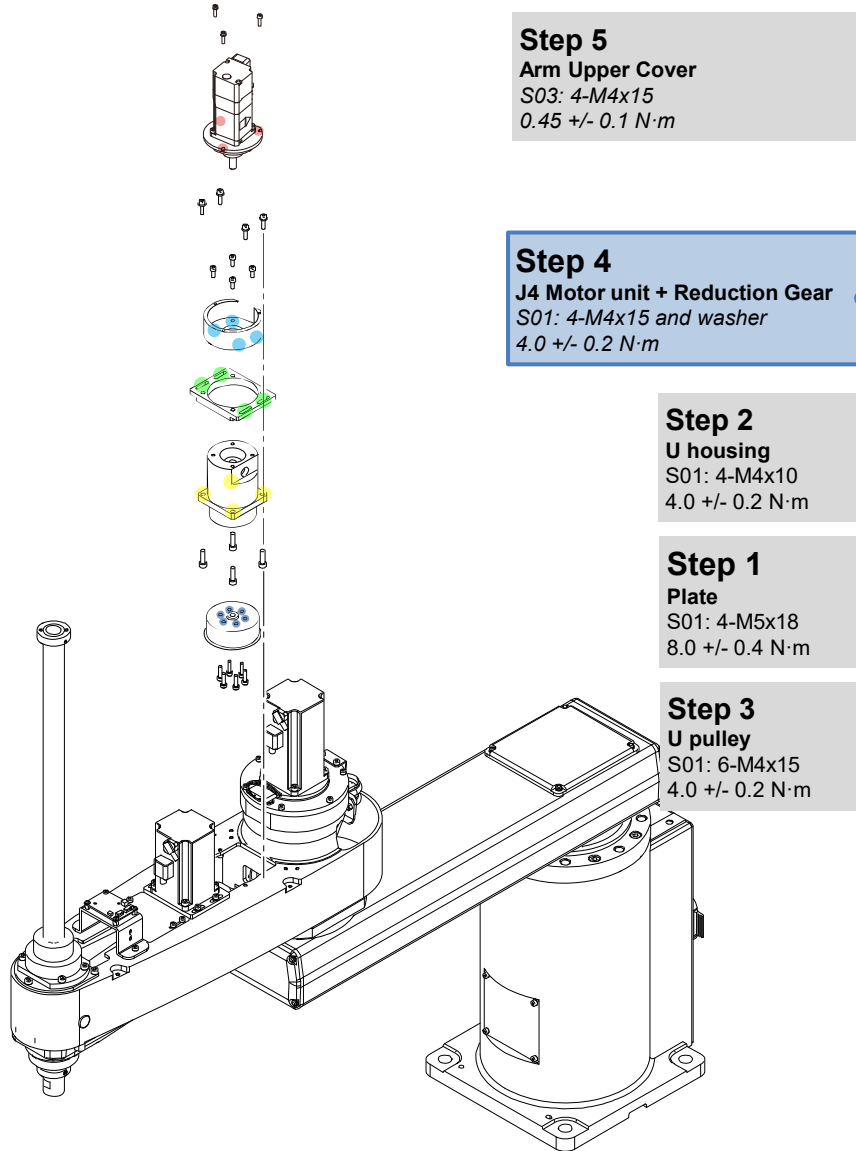

**Step 5**  
**Arm Upper Cover**  
 S03: 4-M4x15  
 0.45 +/- 0.1 N·m

**Step 4**  
**J4 Motor unit + Reduction Gear**  
 S01: 4-M4x15 and washer  
 4.0 +/- 0.2 N·m

**Step 2**  
**U housing**  
 S01: 4-M4x10  
 4.0 +/- 0.2 N·m

**Step 1**  
**Plate**  
 S01: 4-M5x18  
 8.0 +/- 0.4 N·m

**Step 3**  
**U pulley**  
 S01: 6-M4x15  
 4.0 +/- 0.2 N·m

### Connecting the Connectors

Connect the connectors shown in the figure.

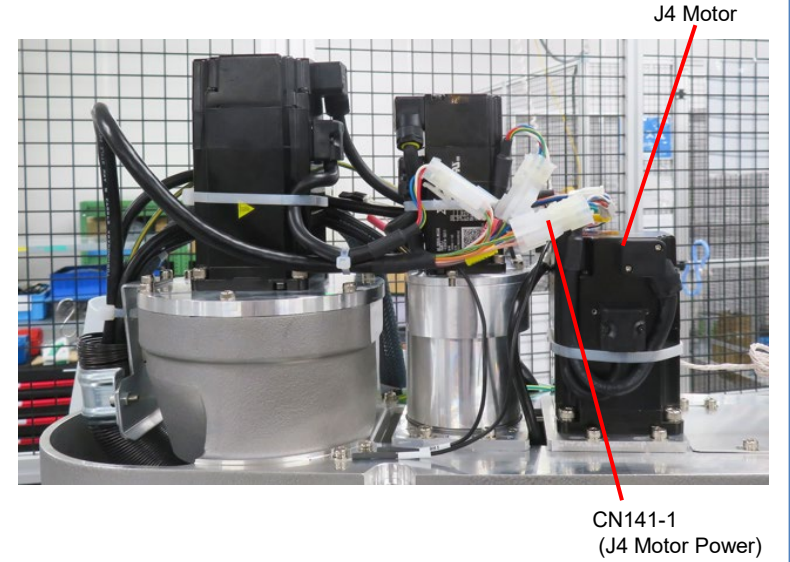

J4 Motor

CN141-1  
 (J4 Motor Power)

## 2.5.7 Installing the J4 Reduction Gear

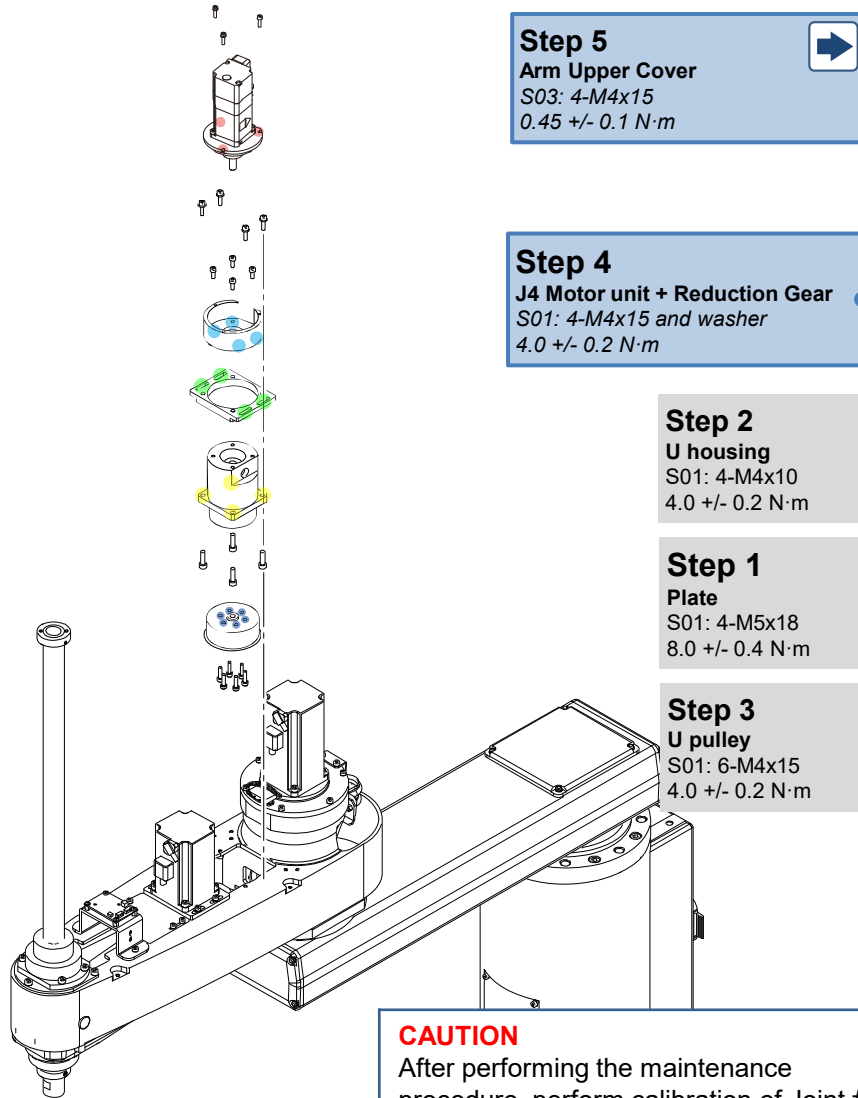

**Step 5**  
**Arm Upper Cover**  
 S03: 4-M4x15  
 0.45 +/- 0.1 N·m

**Step 4**  
**J4 Motor unit + Reduction Gear**  
 S01: 4-M4x15 and washer  
 4.0 +/- 0.2 N·m

**Step 2**  
**U housing**  
 S01: 4-M4x10  
 4.0 +/- 0.2 N·m

**Step 1**  
**Plate**  
 S01: 4-M5x18  
 8.0 +/- 0.4 N·m

**Step 3**  
**U pulley**  
 S01: 6-M4x15  
 4.0 +/- 0.2 N·m

**CAUTION**  
 After performing the maintenance procedure, perform calibration of Joint #4.  
[3.1 Calibration](#)

**Connecting the Motor Unit Connectors**  
 Wrap CN341-1 with the Silicone Sheet together with the other connectors and cables, and secure them with a wire tie (AB150).

**CAUTION**  
 Take care not to apply a load to the cables, for example, by bending the cables with excessive force.

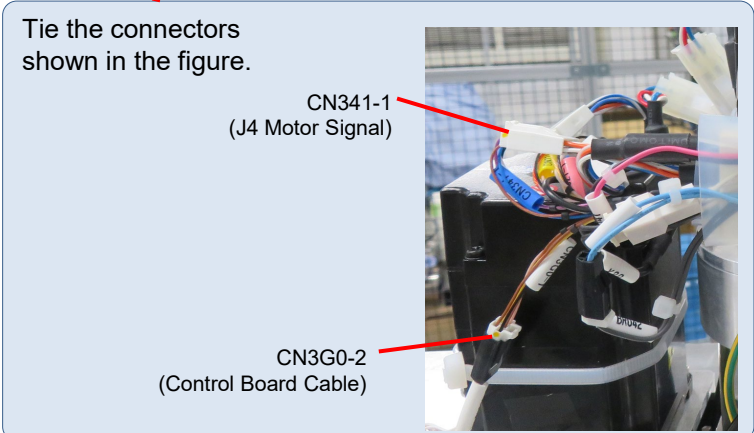
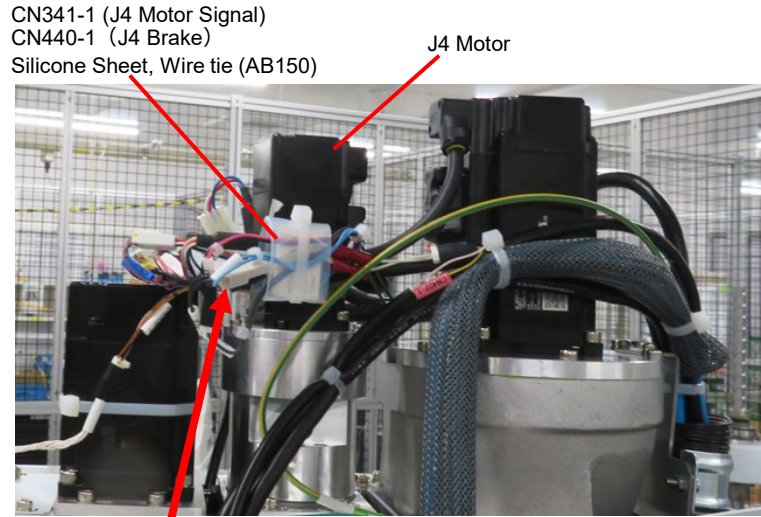

## 2.6 Bellows

Perform the following first before performing maintenance on each part.

### CAUTION

- Replacement of the bellows is accompanied by generation of large amounts of dust. Either perform replacement in a pre-clean room, or after adopting dust prevention measures beforehand.
- The bellows are provided as a set comprising an Upper Bellows and Lower Bellows. Replace each of these bellows, as necessary.
- The Upper Bellows and Lower Bellows have a different shape.

#### Upper Bellows

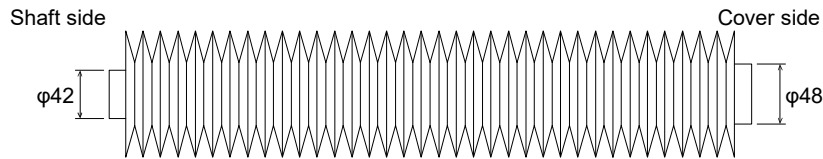

#### Lower Bellows

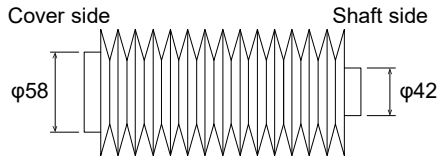

### Preparation

#### Removing the Hand (End Effector)

1. Turn ON the Controller, release the Brake, and lower the Ball Screw Spline to the lower limit.

### CAUTION

- The shaft may lower by the weight of the hand.
- Be careful of the shaft falling and rotating while the Brake Release Switch is being pressed.
- When the Brake is released by the Brake Release Switch, the J3 and J4 Brakes are released.

2. Turn OFF the Controller, and remove the wiring/tubes from the hand.
3. Remove the hand.

#### Protected Model Differences

### CAUTION

The protected models have a gasket foam tape attached to the cover which increases the seal of the bellows. Do not remove this gasket foam tape.

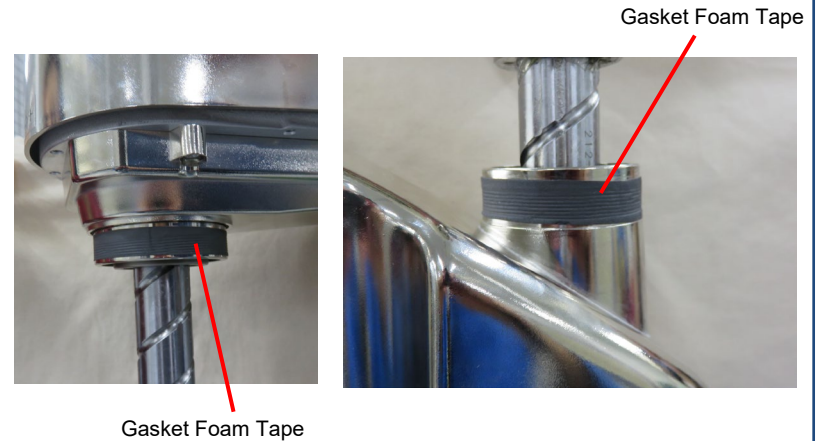

## 2.6.1 Removing the Bellows

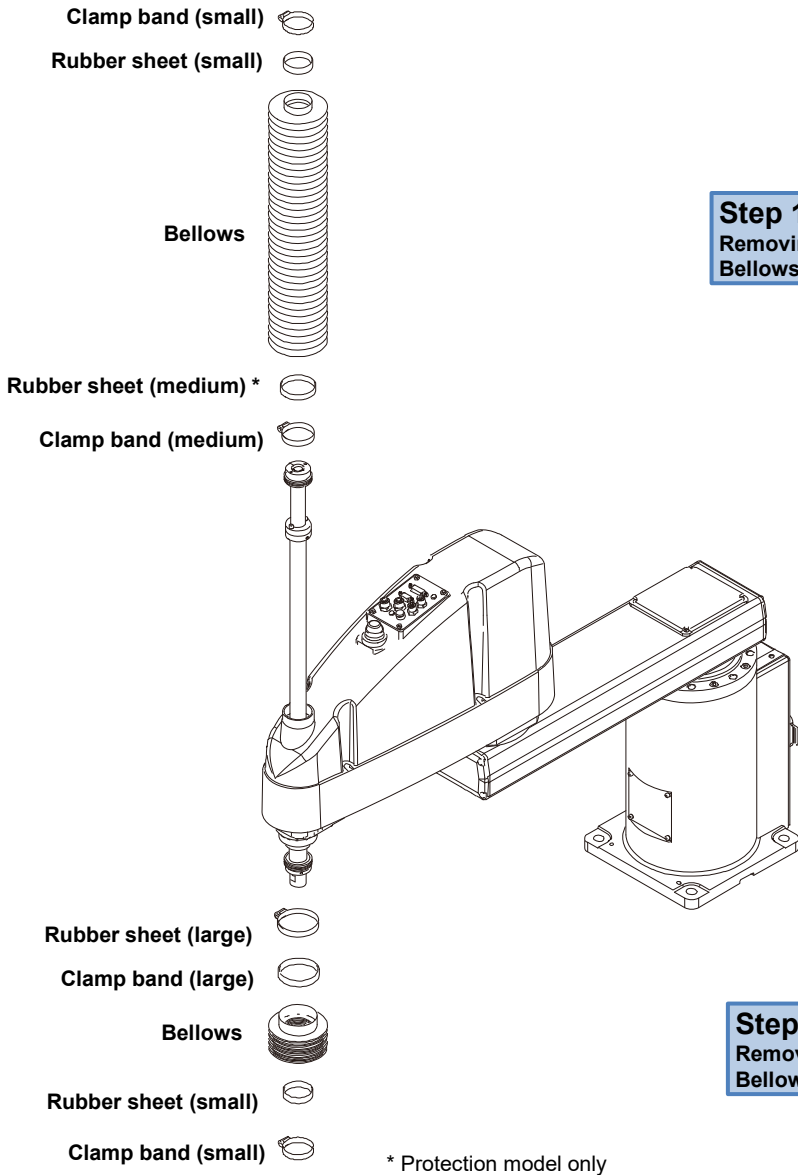

**Step 1**  
Removing the Upper Bellows

Loosen the clamp band securing the Upper Bellows, and remove the Upper Bellows, rubber sheet and clamp band from the shaft.

Screw      Clamp band

Screw      Clamp band

Rubber sheet

Loosen the clamp band securing the Lower Bellows, and remove the Lower Bellows, rubber sheet and clamp band from the shaft.

Screw      Clamp band

Screw      Clamp band

Rubber sheet

**Step 2**  
Removing the Lower Bellows



## 2.6.2 Installing the Bellows

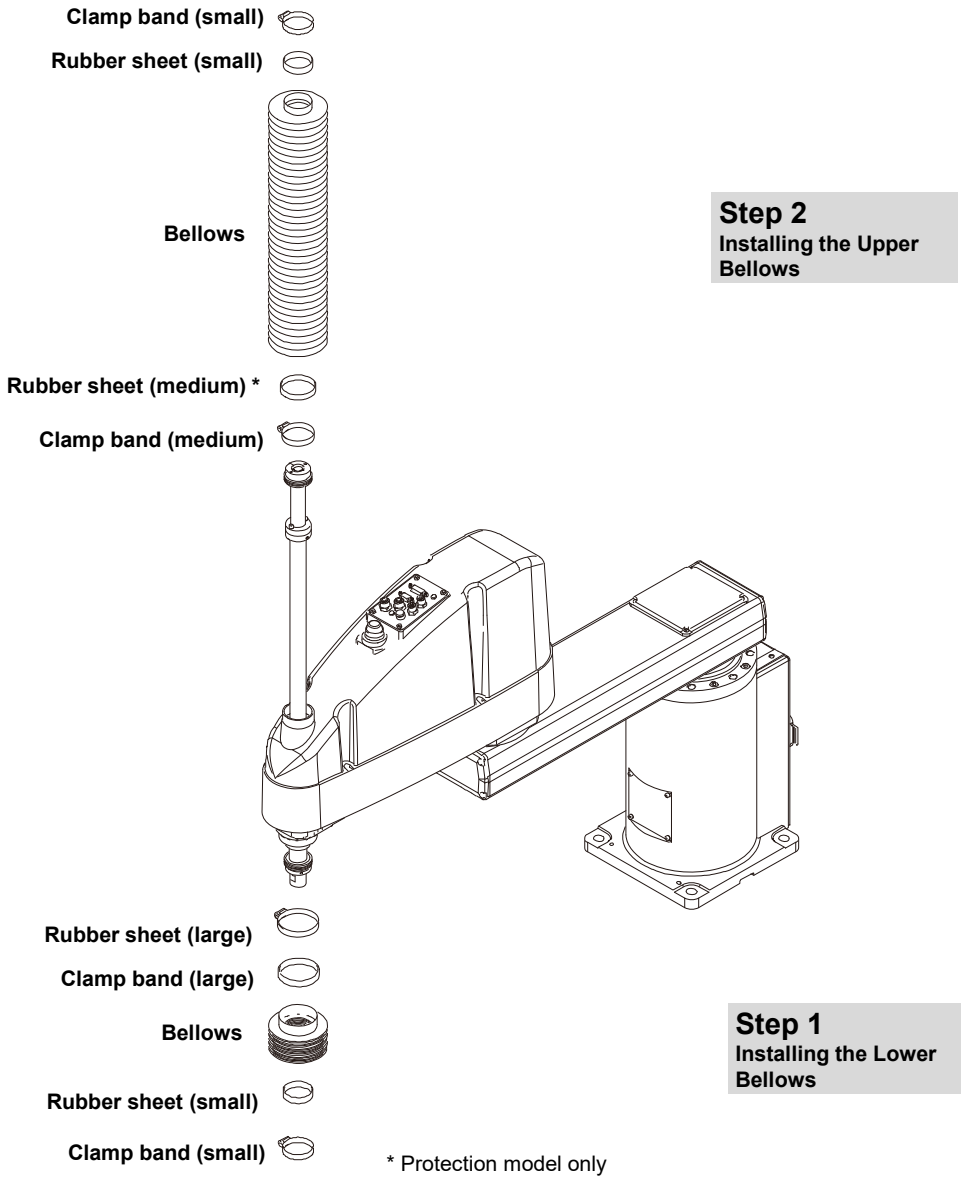

### Preparation

#### Moving the Shaft (Moving to Upper Limit or Lower Limit)

When installing the Upper Bellows, lower the shaft to its lower limit.  
 When installing the Lower Bellows, raise the shaft to its upper limit.

1. Turn ON the Controller.
2. Press the Brake Release Switch, and adjust the shaft in the vertical direction while taking care to prevent the hand from interfering with peripheral devices.

#### CAUTION

- Be careful of the shaft falling and rotating while the Brake Release Switch is being pressed.
- When the Brake is released by the Brake Release Switch, the J3 and J4 Brakes are released.

3. Turn OFF the Controller.

#### CAUTION

- The diameter of the bellows installation section is larger on the cover side and smaller on the shaft end side. When installing the bellows, pass the bellows onto the shaft from the installation section with the larger diameter first.
- There are three types of clamp band: large, medium, and small. Be careful not to use the wrong clamp band.

#### Upper Bellows

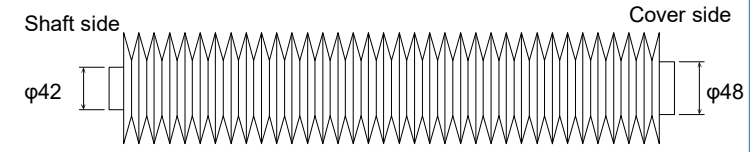

#### Lower Bellows

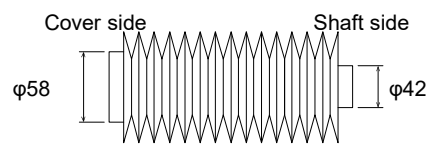

## 2.6.2 Installing the Bellows

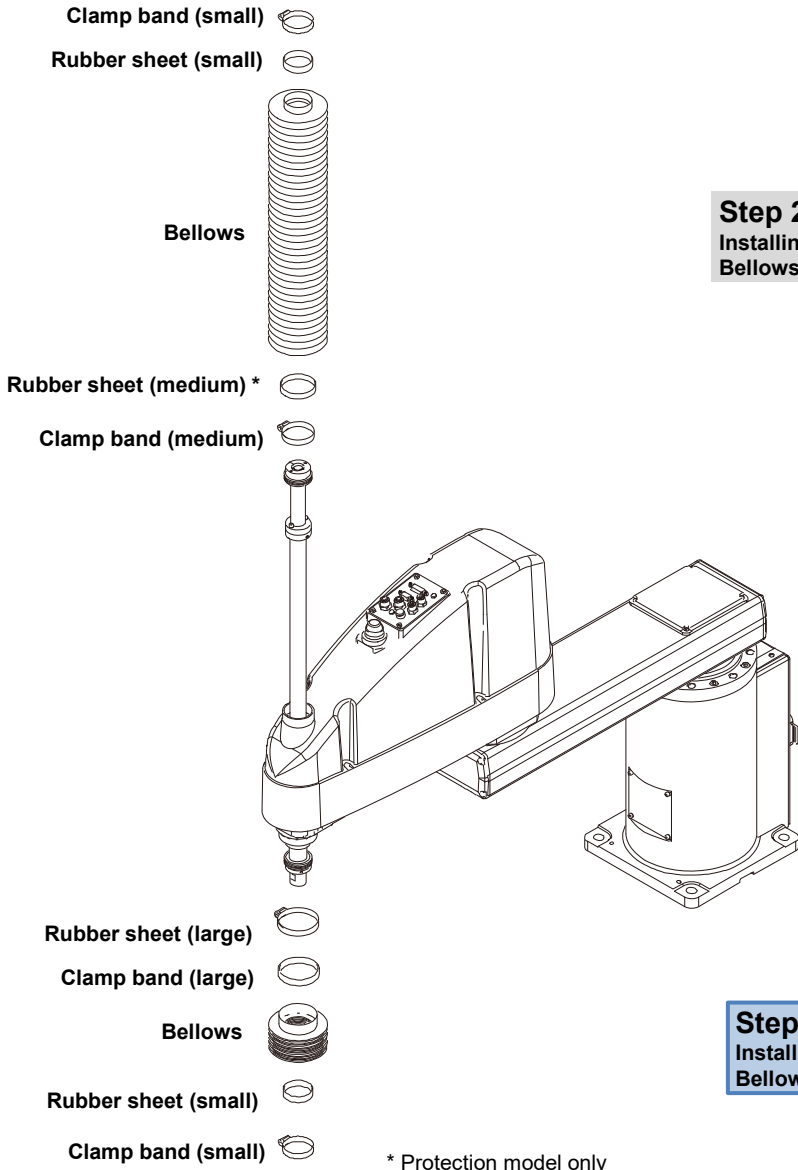

**Step 2**  
Installing the Upper Bellows

**Step 1**  
Installing the Lower Bellows

\* Protection model only

### POINT

Pass the bellows onto the shaft from the installation section with the larger diameter first.

1. Insert the bellows until the end of the bellows installation section contacts the cylinder part of the cover.
2. Attach the rubber sheet onto the end face of the clamp band. Attach the rubber sheet to fit flush so that a gap is not formed at the bias cut section.
3. Tighten the screw of the clamp band to secure the band in place.
4. Fit the bellows installation section over the bearing case, and attach the rubber sheet. Attach the rubber sheet to fit flush so that a gap is not formed at the bias cut section.
5. Tighten the screw of the clamp band to secure the band in place.

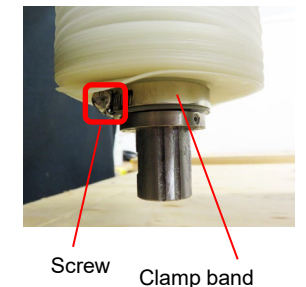
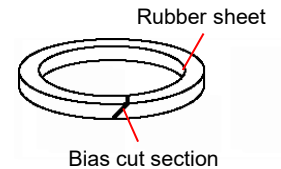
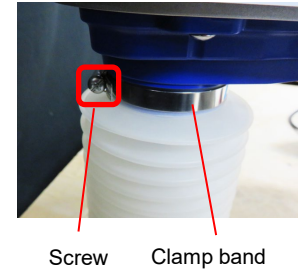
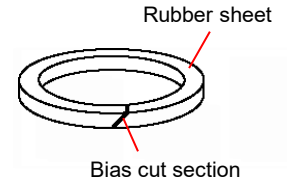



## 2.6.2 Installing the Bellows

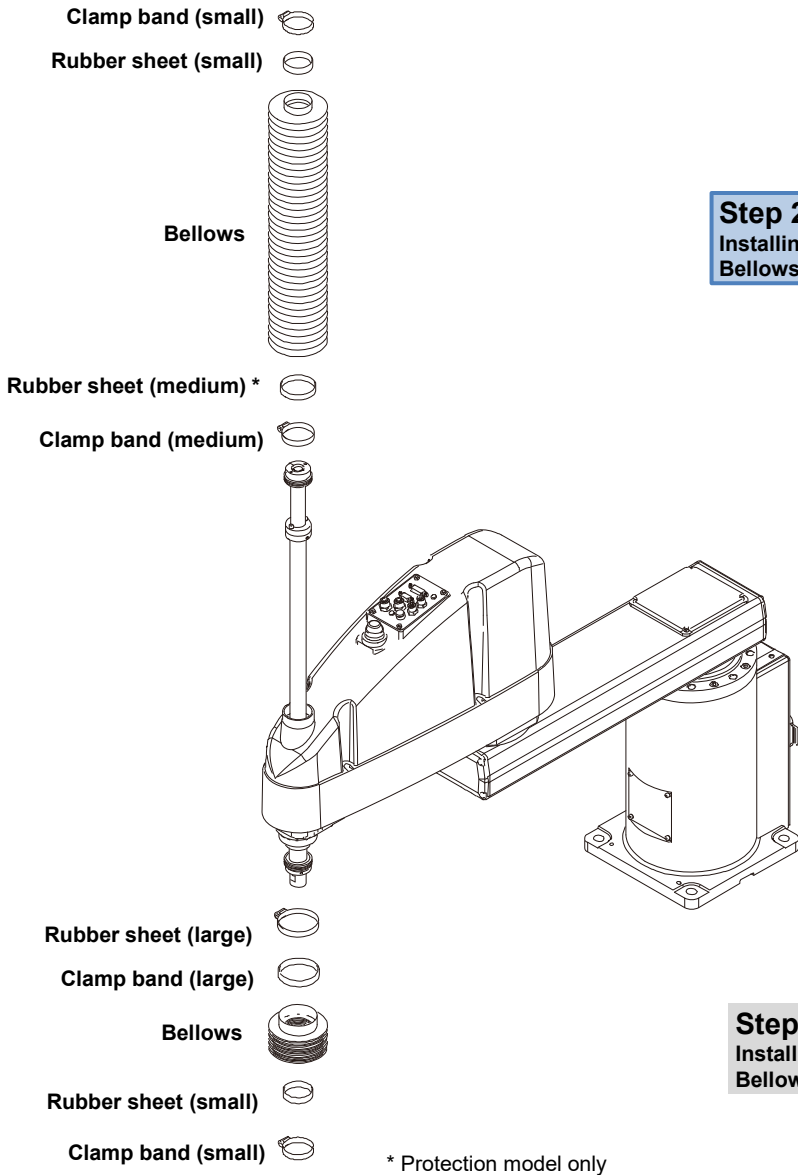

**Step 2**  
Installing the Upper Bellows

**Step 1**  
Installing the Lower Bellows

\* Protection model only

1. Insert the bellows until the end of the bellows installation section contacts the cylinder part of the cover.
2. Attach the rubber sheet onto the end face of the clamp band. Attach the rubber sheet to fit flush so that a gap is not formed at the bias cut section.
3. Tighten the screw of the clamp band to secure the band in place.
4. Fit the bellows installation section over the bearing case, and attach the rubber sheet. Attach the rubber sheet to fit flush so that a gap is not formed at the bias cut section.
5. Tighten the screw of the clamp band to secure the band in place.

The diagrams illustrate the following steps:

- Attaching a rubber sheet to a clamp band, showing the bias cut section.
- Tightening a screw on the clamp band to secure it.
- Attaching a rubber sheet to a clamp band over a bearing case, showing the bias cut section.
- Tightening a screw on the clamp band to secure it over the bearing case.

## 2.7 Ball Screw Spline Unit

### 2.7.1 Removing the Ball Screw Spline Unit

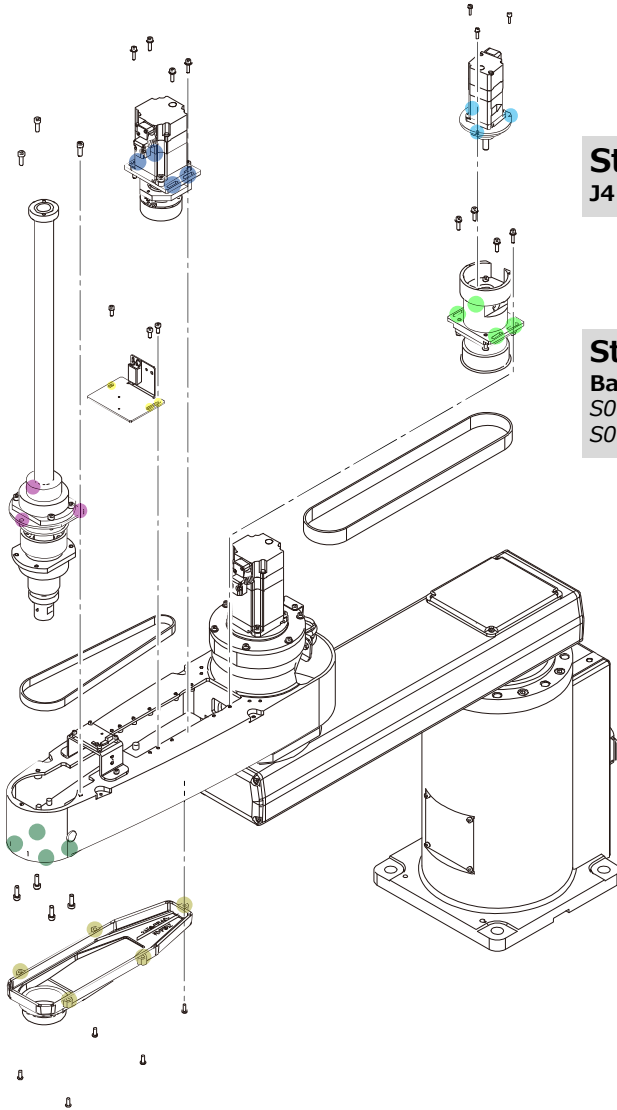

#### Step 1 J4 Timing Belt (U)

#### Step 2 Ball Screw Spline Unit S01: 3-M5x15 S01: 4-M5x15

### Preparation

#### Removing the Hand (End Effector)

1. Turn ON the Controller, release the Brake, and lower the Ball Screw Spline to the lower limit.

#### CAUTION

- The shaft may lower by the weight of the hand.
- Be careful of the shaft falling and rotating while the Brake Release Switch is being pressed.
- When the Brake is released by the Brake Release Switch, the J3 and J4 Brakes are released.

2. Turn OFF the Controller, and remove the wiring/tubes from the hand.
3. Remove the hand.

#### Removing the Bellows

If a bellows have been attached, remove them. 

## 2.7.1 Removing the Ball Screw Spline Unit

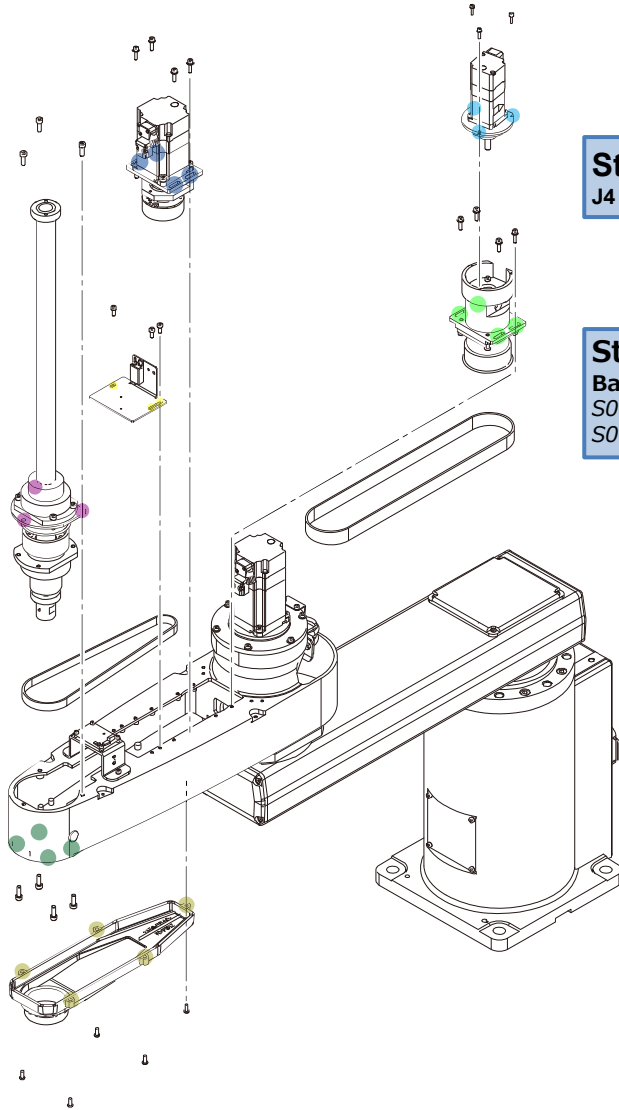

**Step 1**  
J4 Timing Belt (U)



**Step 2**  
Ball Screw Spline Unit  
S01: 3-M5x15  
S01: 4-M5x15

**POINT**  
Perform the procedure up to Step 5.

Remove the bolts securing the Spline Plate to Arm2.

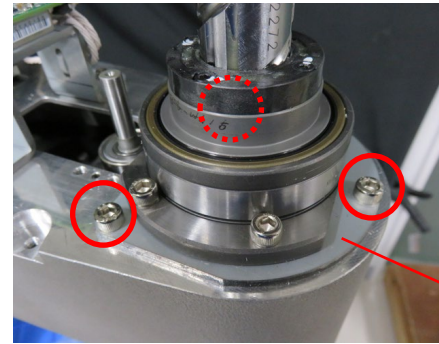

Spline Plate

Remove the bolts securing the shaft of the Ball Screw Spline on the underneath of Arm2, then the Ball Screw Spline Unit can be removed from Arm2.

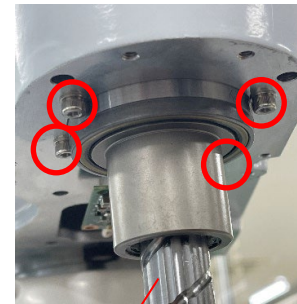

Shaft

## 2.7.2 Installing the Ball Screw Spline Unit

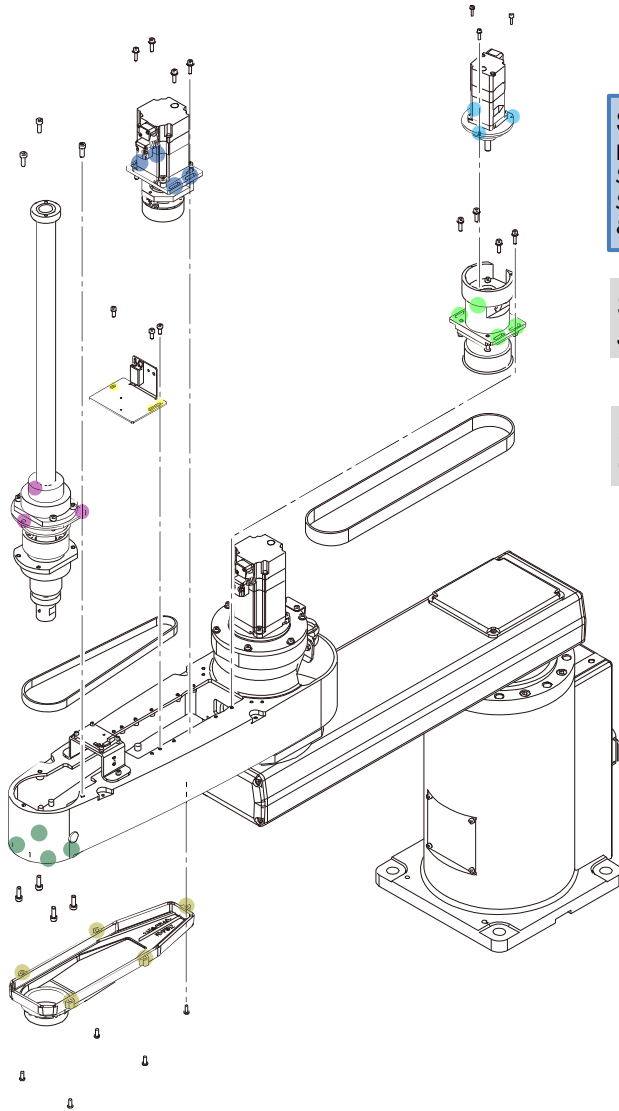

**Step 1**  
**Ball Screw Spline Unit**  
 S01: 3-M5x15  
 S01: 4-M5x15  
 8.0 +/-0.4 N·m

**Step 2**  
**J4 Timing Belt (U)**

**Step 3**  
**Greasing**

**POINT**  
 Insert the Ball Screw Spline Unit to Arm2 while passing the Z belt and U belt onto the shaft.  
 As shown in the figure, place the belt on the Ball Screw Spline Unit.

**CAUTION**  
 If the Timing Belt is placed on the flange, correct tension will not be obtained during belt tension adjustment.

Set the belt so that it is level with respect to the pulley without it being placed on the flange.

## 2.7.2 Installing the Ball Screw Spline Unit

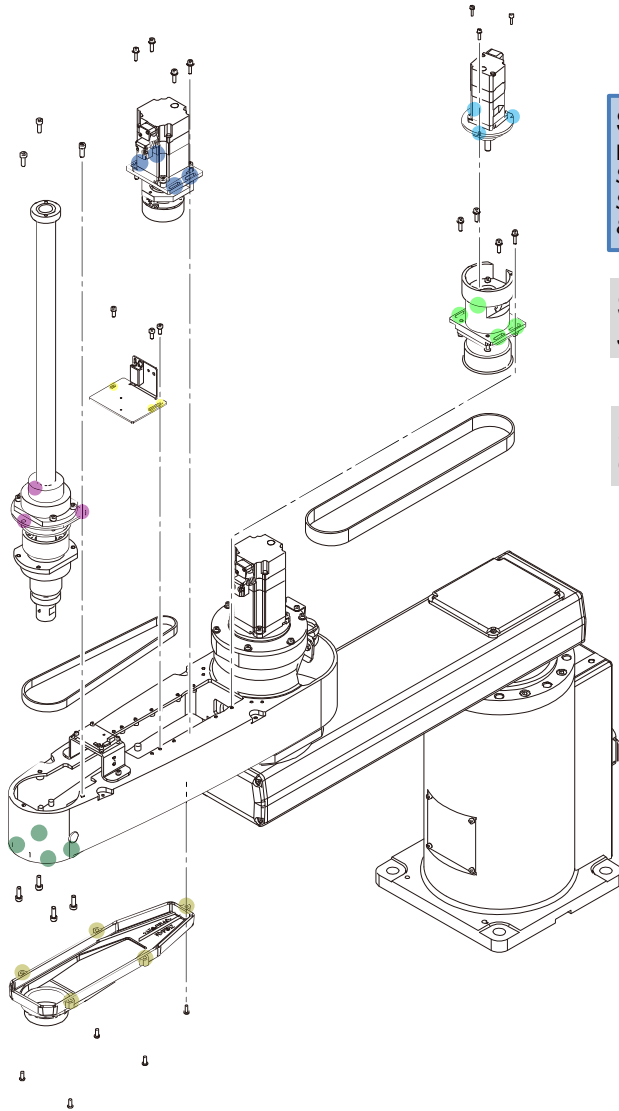

**Step 1**  
**Ball Screw Spline Unit**  
 S01: 3-M5x15  
 S01: 4-M5x15  
 8.0 +/-0.4 N·m

**Step 2**  
**J4 Timing Belt (U)**

**Step 3**  
**Greasing**

**POINT**

Temporarily secure the Ball Screw Spline Unit on Arm2.

Arm bottom surface

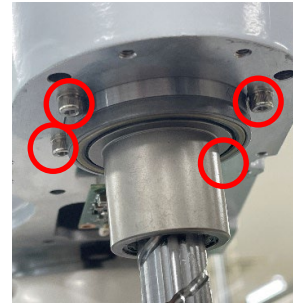

S01: 4-M5x15

Arm top surface

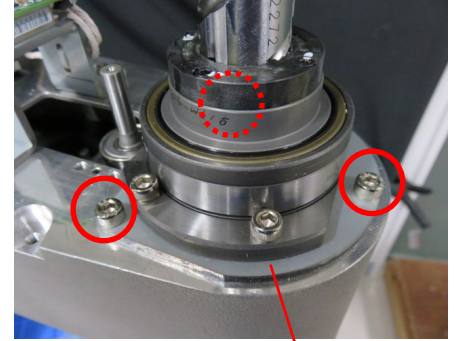

S01: 3-M5x15

Spline Plate

**CAUTION**

Take care to prevent the Timing Belt from being caught between the nut and Arm2.

After temporary tightening, perform centering. Move the Ball Screw Spline Unit up and down. The Ball Screw Spline Unit will be positioned to the center of the arm.

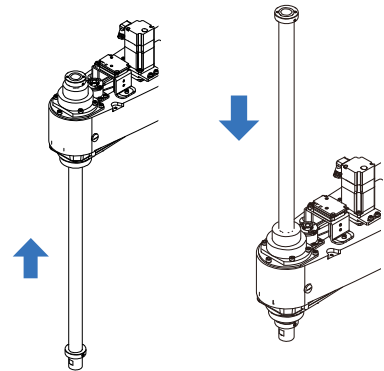

**CAUTION**

After performing adjustment, secure the Ball Screw Spline Unit.

## 2.7.2 Installing the Ball Screw Spline Unit

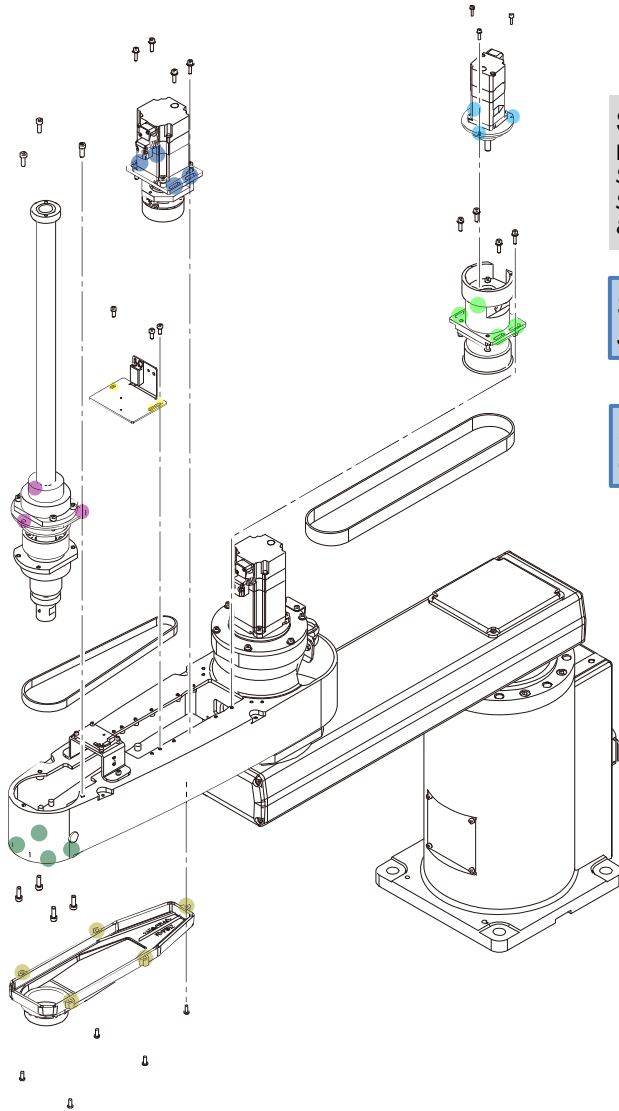

**Step 1**  
**Ball Screw Spline Unit**  
 S01: 3-M5x15  
 S01: 4-M5x15  
 8.0 +/-0.4 N·m

**Step 2**   
**J4 Timing Belt (U)**

**Step 3**   
**Greasing**

**CAUTION**  
 Be sure to perform greasing.

**After Work**

**Installing the Hand (End Effector)**  
 Install the hand and wiring and piping to the hand.

**Installing the Bellows**  
 Install the bellows if they are provided. 

**CAUTION**  
 After performing the maintenance procedure, perform calibration of Joint #3 and Joint #4.  
[3.1 Calibration](#)

## 2.7.3 Greasing the Ball Screw Spline Unit

### Standard model

- (1) Manually move Arm1 and Arm2 to a position where a full stroke operation can be performed on Z-axis.

#### CAUTION

When moving the Ball Screw Spline Unit to the upper or lower position, make sure that the Z-axis does not interfere with the peripheral devices.

- (2) Remove the Arm2 Cover.

- (3) Turn ON the Controller.

#### CAUTION

- Stop motor excitation (motor OFF). The lamp does not light in this state.
- Even when the motor is OFF, voltage is present in the cables and the circuit board. Do not touch parts related to the power supply while the Controller is ON.

- (4) Move the shaft to its upper limit manually while pressing the Brake Release Switch, and turn OFF the Controller.

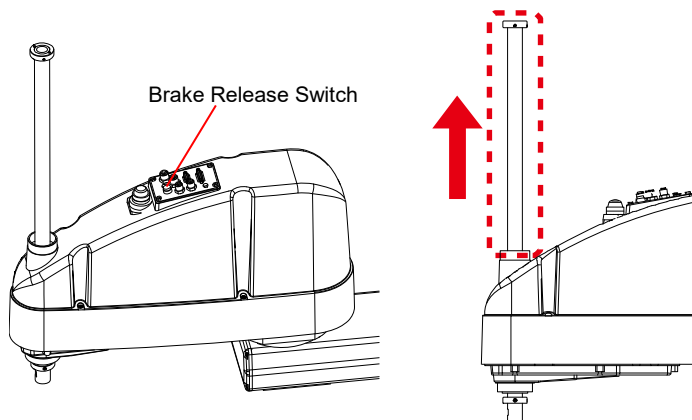

- (5) Wipe off the old grease and then apply new grease.

#### CAUTION

Apply grease by hand to the extent that the shaft groove is filled with grease. Wipe off the excess grease so that it does not get scattered to the workpiece and peripheral equipment.

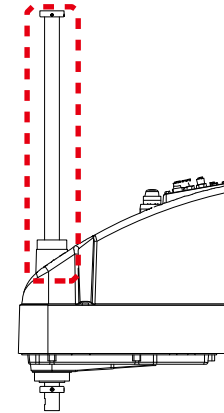

- (6) Turn ON the Controller.

- (7) Move the shaft to its lower limit manually while pressing the Brake Release Switch, and turn OFF the Controller.



- (8) Wipe off the old grease and then apply new grease.

**CAUTION**

Apply grease by hand to the extent that the shaft groove is filled with grease. Wipe off the excess grease so that it does not get scattered to the workpiece and peripheral equipment.

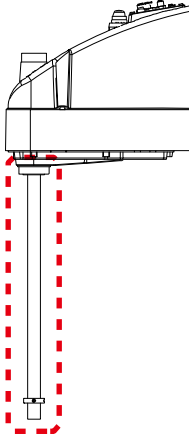

- (9) Turn ON the Controller.
- (10) Move the shaft up and down a few times while pressing the Brake Release Switch so that the grease spreads uniformly in the shaft.

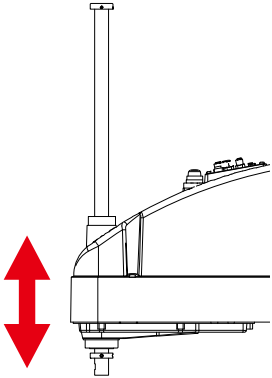

- (11) Turn OFF the Controller, and wipe off the excess grease from the shaft.

Cleanroom model/Protection model

Protected Model Differences

**CAUTION**

The protected models have a gasket foam tape attached to the cover which increases the seal of the bellows. Do not remove this gasket foam tape.

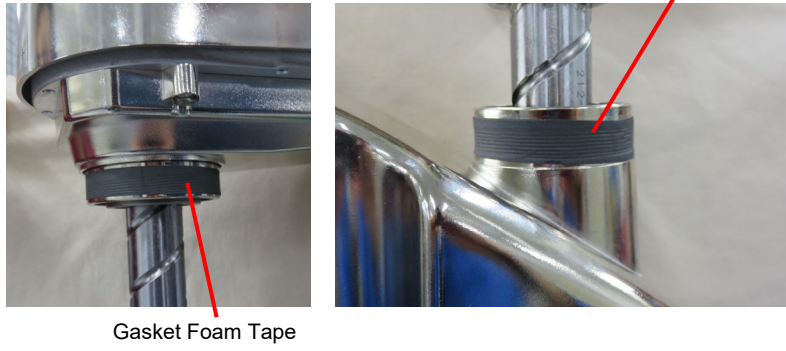

- (1) Manually move Arm1 and Arm2 to a position where a full stroke operation can be performed on Z-axis.

**CAUTION**

- To ensure that grease does not get deposited during maintenance, cover the hand (end effector) and peripheral devices with a cloth.
- When moving the Ball Screw Spline Unit to the upper or lower position, make sure that the Z-axis does not interfere with the peripheral devices.

- (2) Remove the Arm2 Cover.

- (3) Turn ON the Controller.

**CAUTION**

- Stop motor excitation (motor OFF). The lamp does not light in this state.
- Even when the motor is OFF, voltage is present in the cables and the circuit board. Do not touch parts related to the power supply while the Controller is ON.

- (4) Move the shaft to its upper limit manually while pressing the Brake Release Switch, and turn OFF the Controller.

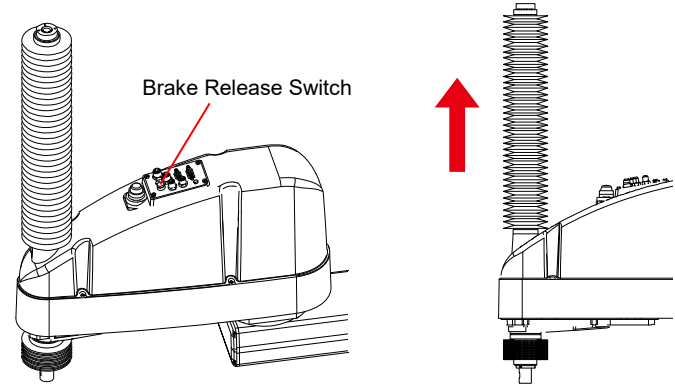

- (5) Loosen the clamp band and raise the Bellows till the position shown in the figure.

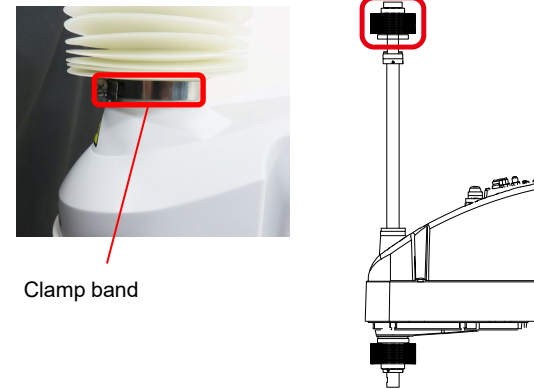

**POINT**

Use a plastic clip or something similar to ensure that the Bellows does not lower.



- (6) Wipe off the old grease and then apply new grease.

**CAUTION**

Apply grease by hand to the extent that the shaft groove is filled with grease.

Wipe off the excess grease.

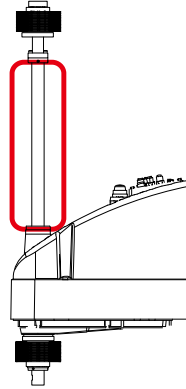

- (7) Turn ON the Controller.

- (8) Move the shaft to its lower limit manually while pressing the Brake Release Switch, and turn OFF the Controller.

- (9) Loosen the clamp band and lower the Bellows till the position shown in the figure.

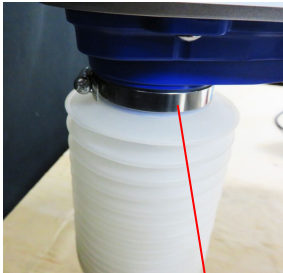

Clamp band

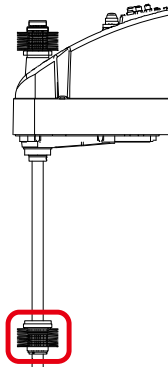

**POINT**

Use a plastic clip or something similar to ensure that the Bellows does not drop below the bottom of the shaft.

- (10) Wipe off the old grease and then apply new grease.

**CAUTION**

Apply grease by hand to the extent that the shaft groove is filled with grease. Wipe off the excess grease.

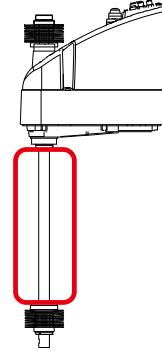

- (11) Turn ON the Controller.

- (12) Move the shaft up and down a few times while pressing the Brake Release Switch so that the grease spreads uniformly in the shaft.

**CAUTION**

When moving the shaft up and down, take care that the Bellows does not touch the cover.

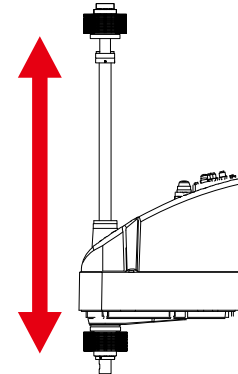

- (13) Turn OFF the Controller, and wipe off the excess grease from the shaft.

## 2.8 Board, LED Indicator

### 2.8.1 Replacing the DC/DC Board

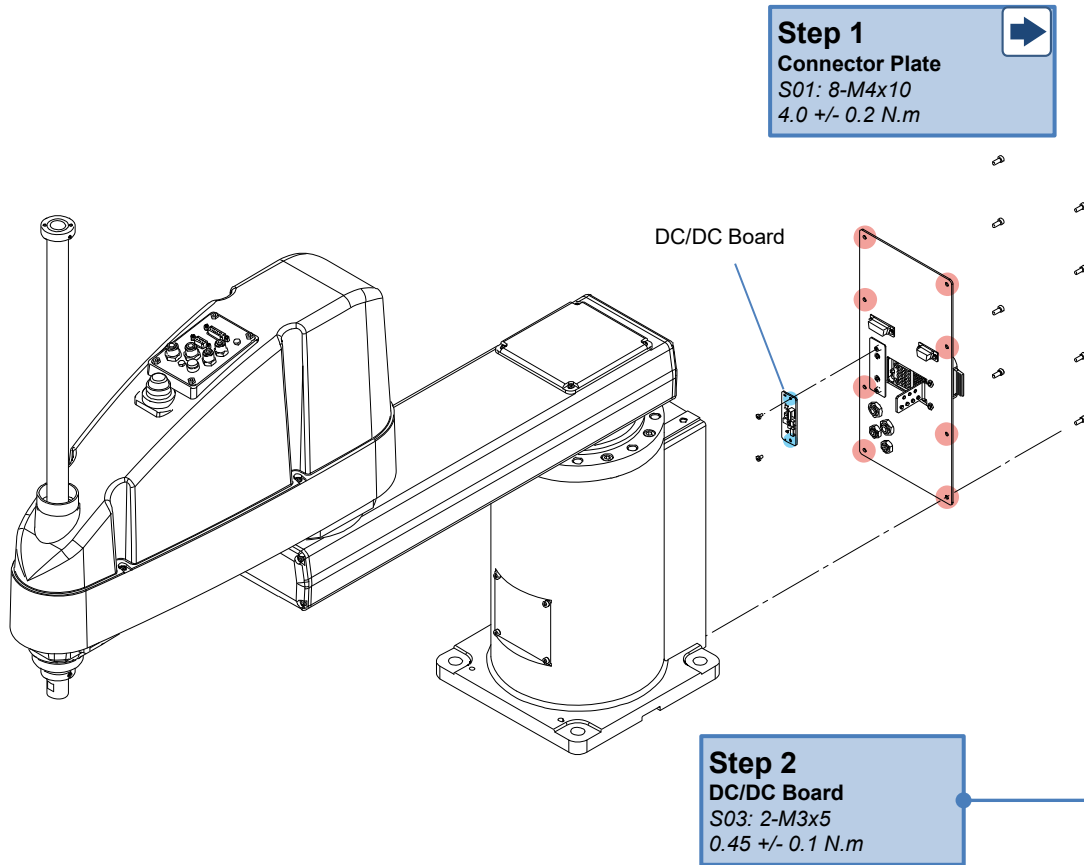

**Disconnecting the connectors**

**CAUTION**  
When installing the board, be careful not to pinch the cables.

\* The disassembly procedure is described here.  
Perform assembly by following the disassembly procedure in the reverse order.

## 2.8.2 Replacing the Control Board

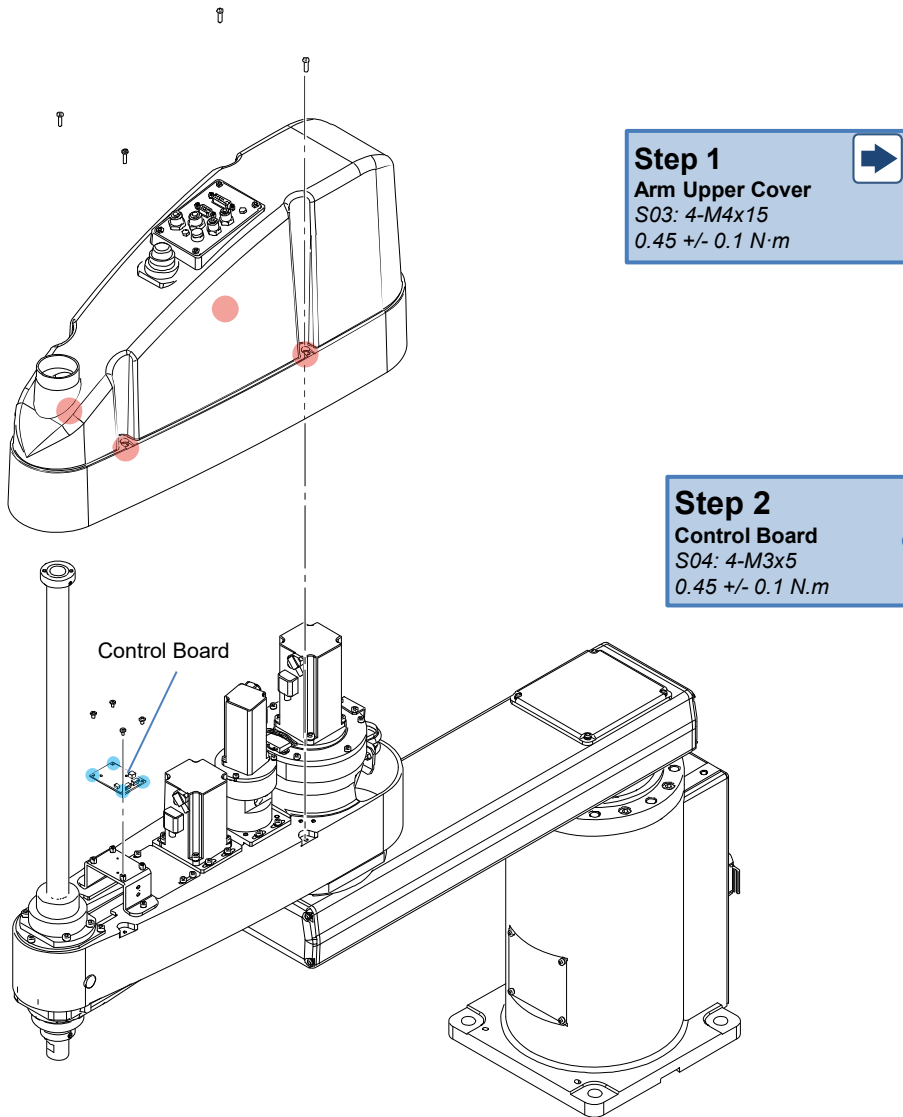

**CAUTION**

As the board components and screws are close together, take care not to damage the board when removing or fixing the screws.

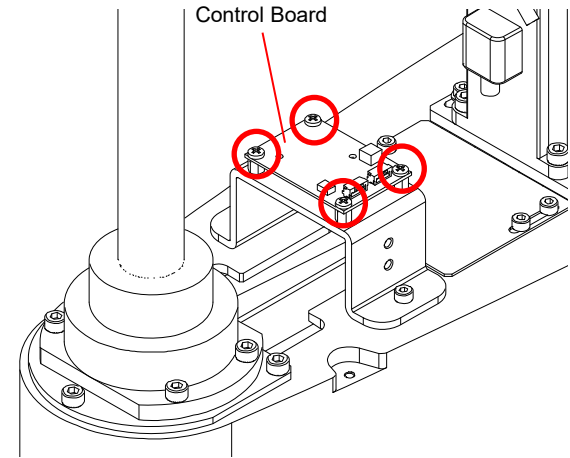

**Disconnecting the connectors**

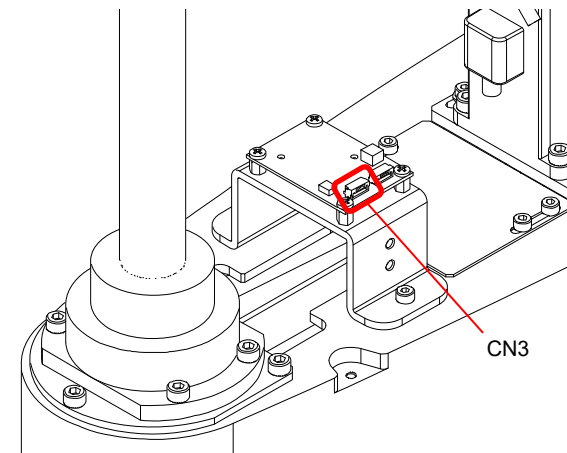

\* The disassembly procedure is described here.  
 Perform assembly by following the disassembly procedure in the reverse order.

### 2.8.3 Replacing the LED Indicator

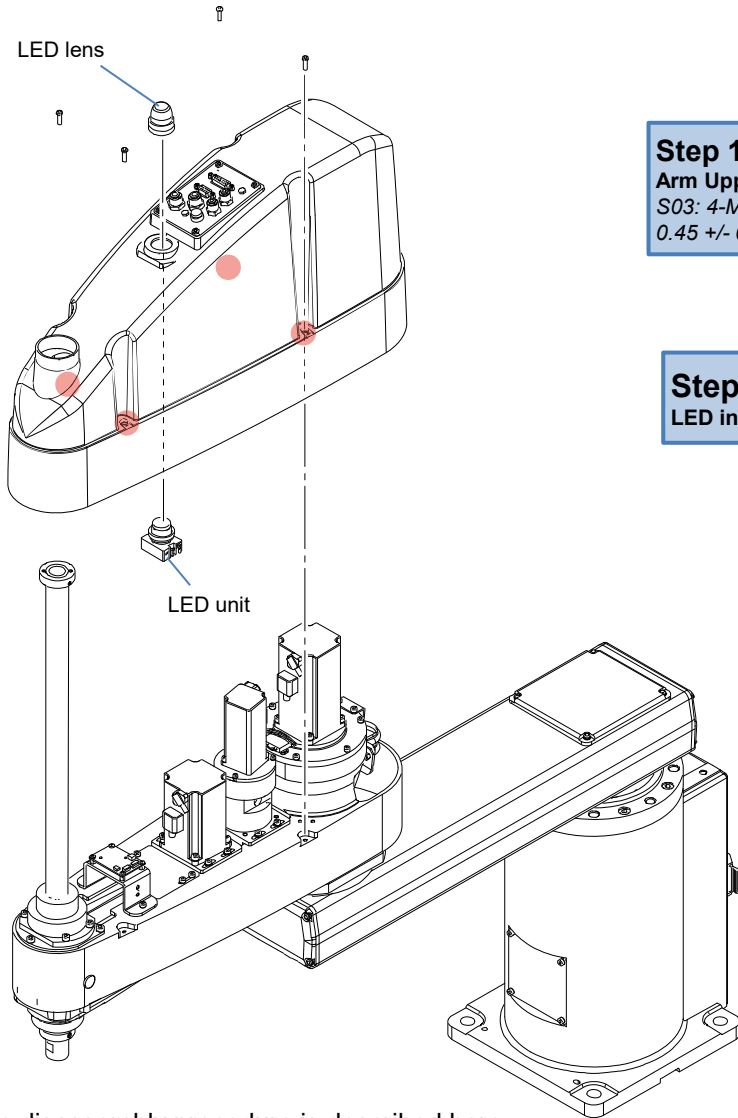

**Step 1**  
 Arm Upper Cover  
 S03: 4-M4x15  
 0.45 +/- 0.1 N·m

**Step 2**  
 LED indicator

#### Removing the LED Indicator

1. Remove the terminal connected to the LED unit.



2. Remove the lens and lens holder.  
Turn counterclockwise to remove these.
3. Remove the LED unit and ring from the Arm Upper Cover.

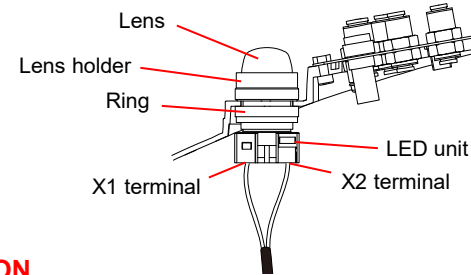

**CAUTION**

When the lens and lens holder are removed, the LED unit comes away from the cover. Pay attention as it may fall off.

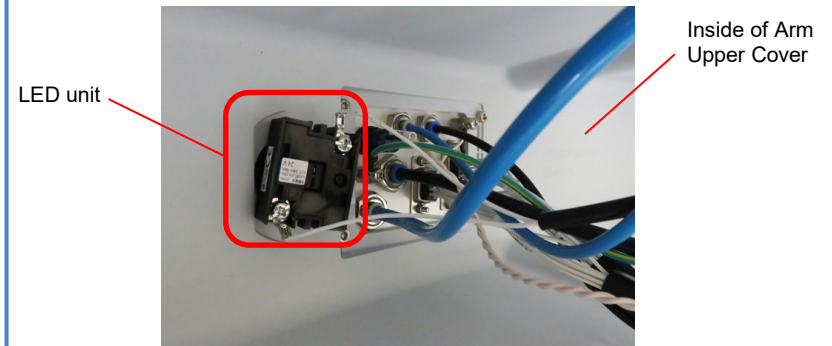

\* The disassembly procedure is described here.  
 Perform assembly by following the disassembly procedure in the reverse order.

## 2.9 Cable Unit

### 2.9.1 Removing the Cable Unit

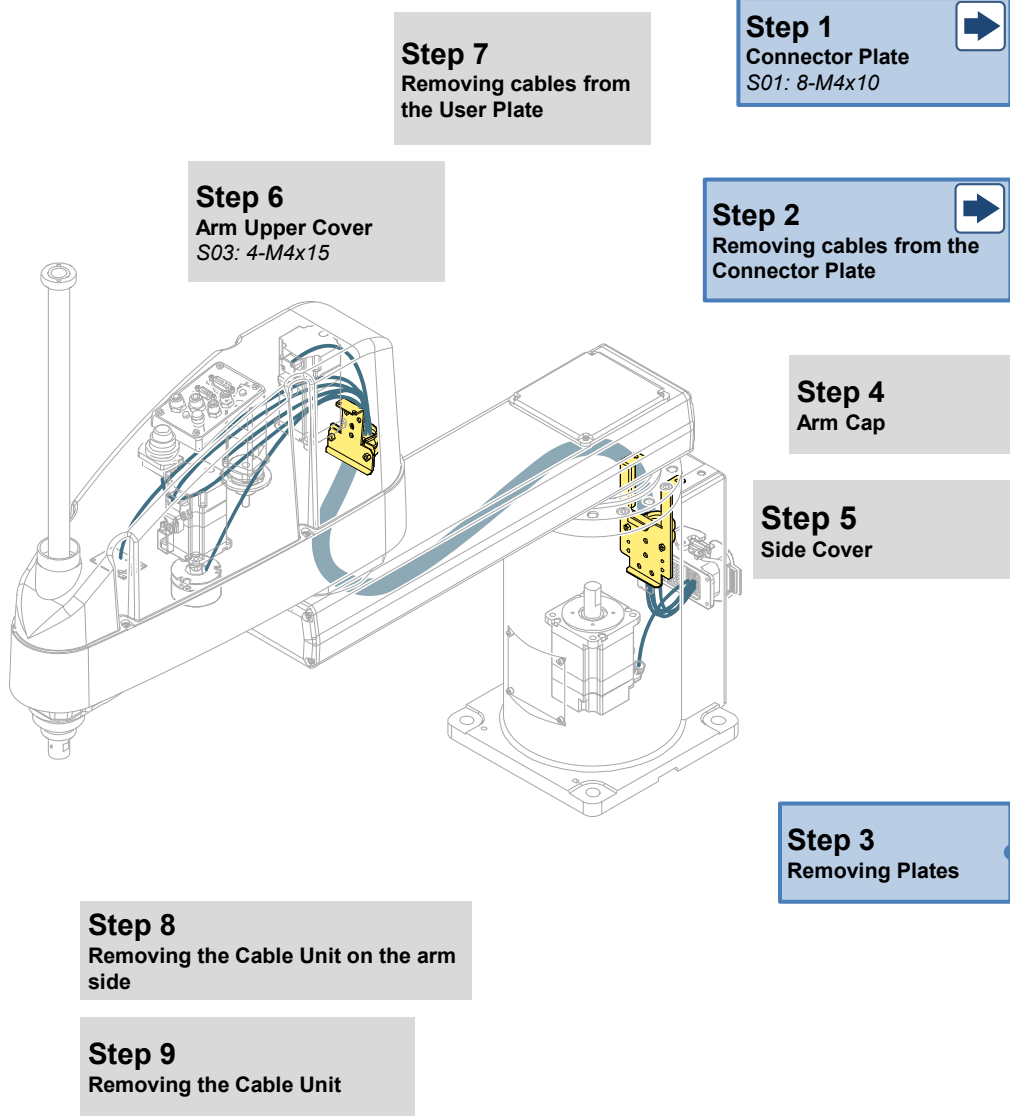

**CAUTION**

- When removing the Cable Unit from the Manipulator, take care to prevent the connectors and brackets from getting caught.
- Replace the cables as a unit, not individually.

**NOTE**

Depending on the installation type of the Manipulator, the work sequence may vary.

**Table Top Mounting Type/Ceiling Mounting Type**

1. Remove the Saddle Clamp and FB cable.

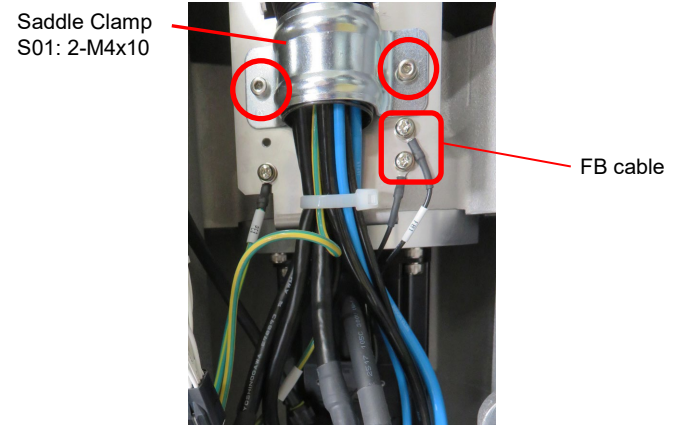

2. Remove the Spring Fixing Plate.

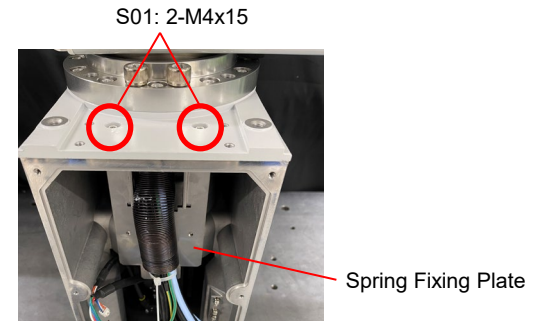



### 2.9.1 Removing the Cable Unit

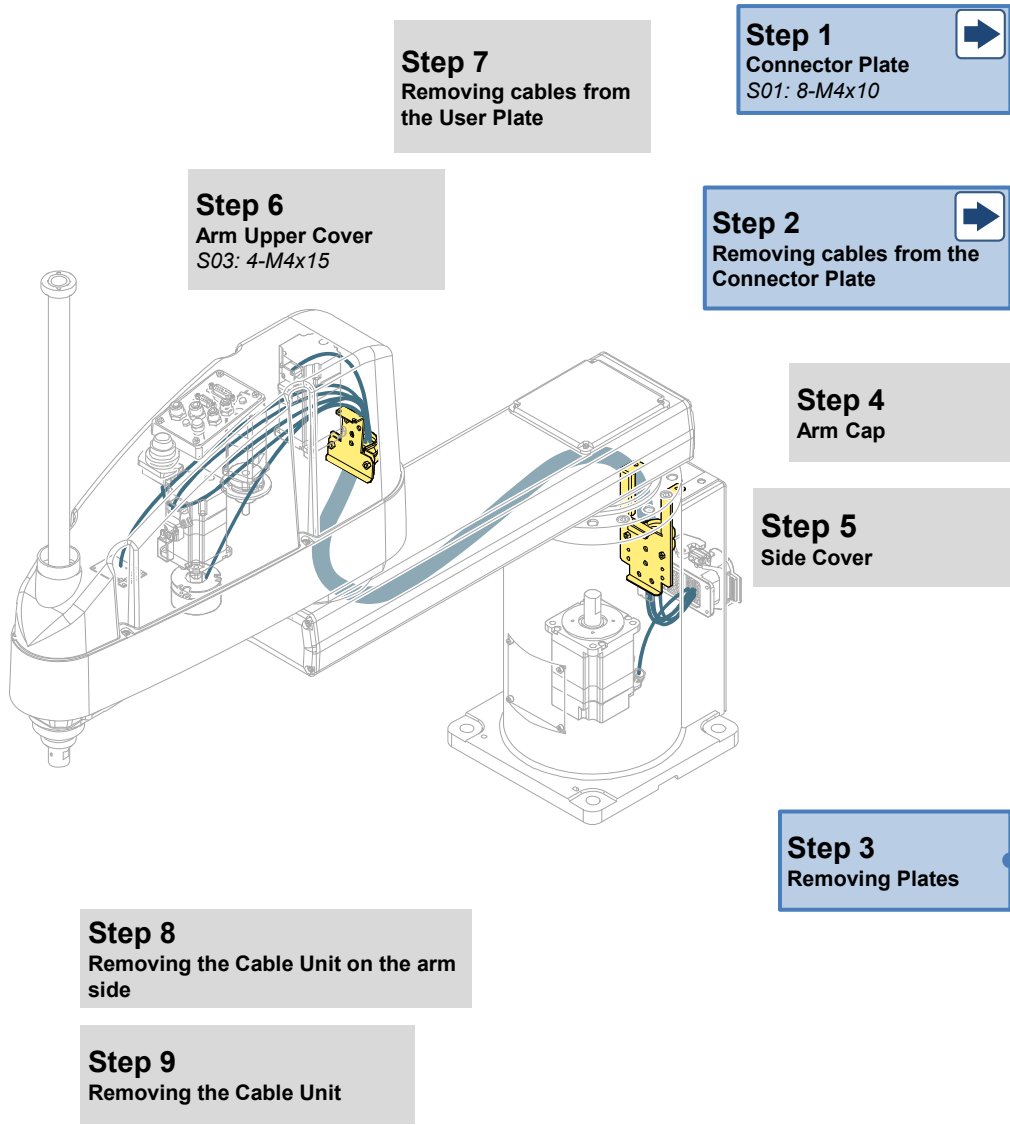

3. Remove the wire tie from the Spring Fixing Plate and remove the Cable Unit.

Spring Fixing Plate

Wire tie

## 2.9.1 Removing the Cable Unit

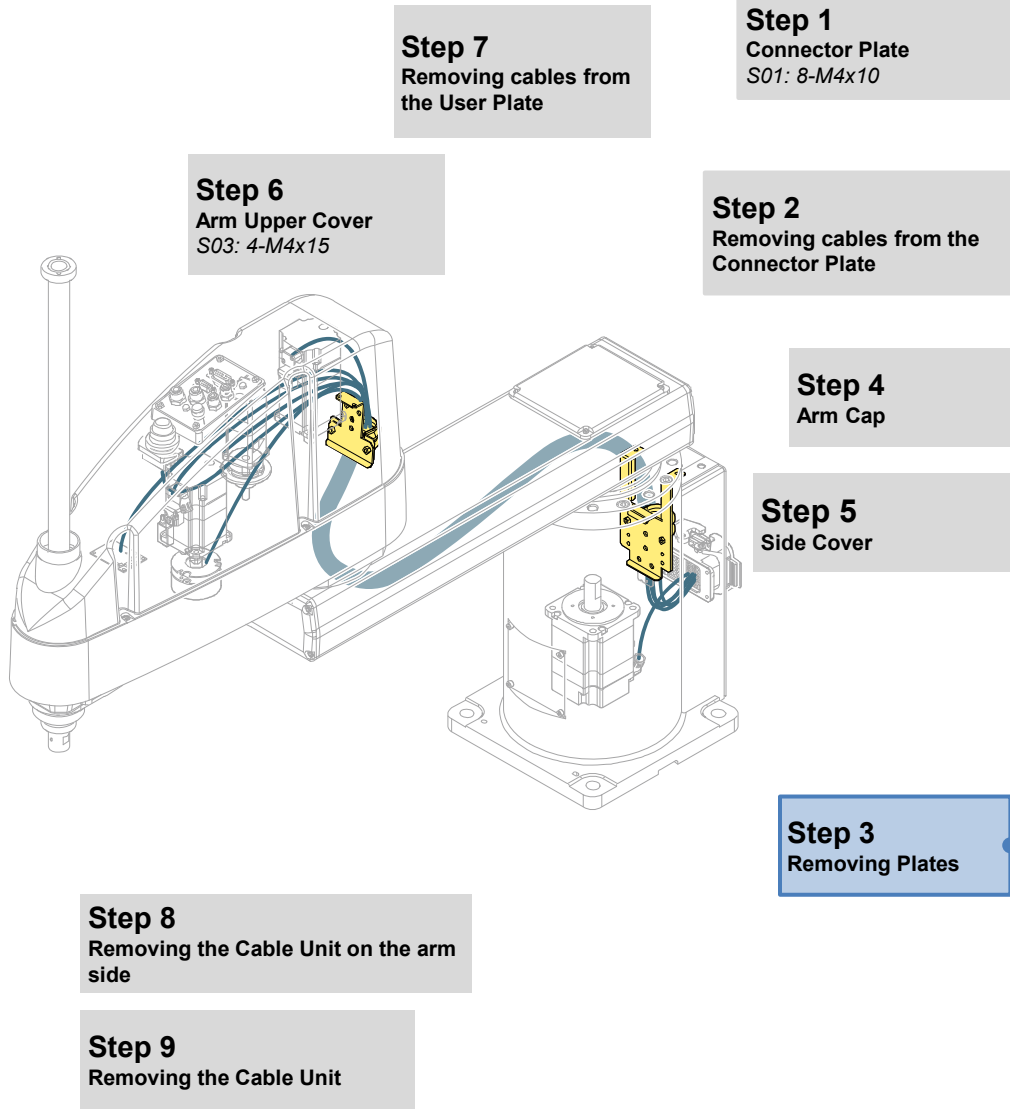

### Wall Mounting Type

1. Remove the Ground Plate.

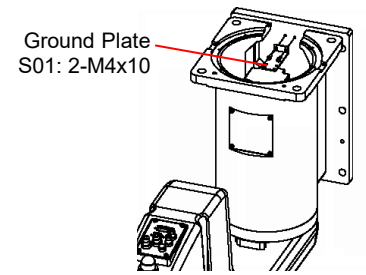

2. Remove the Spring Fixing Plate from the base.

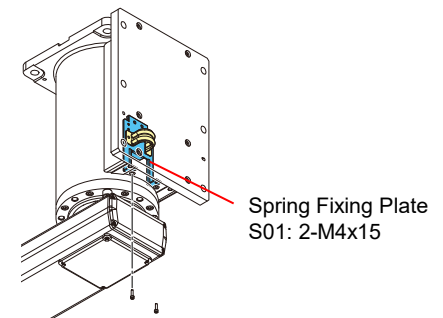

3. Remove the FB cable and the wire tie securing the cable.

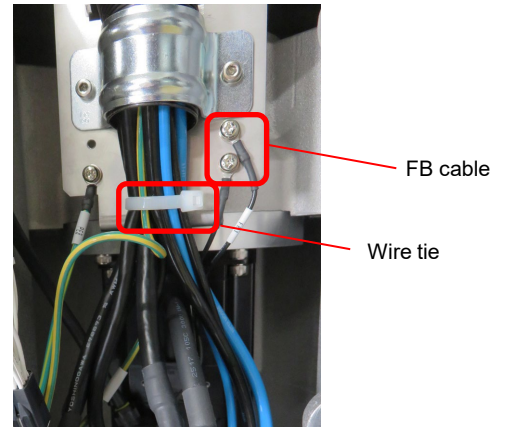

## 2.9.1 Removing the Cable Unit

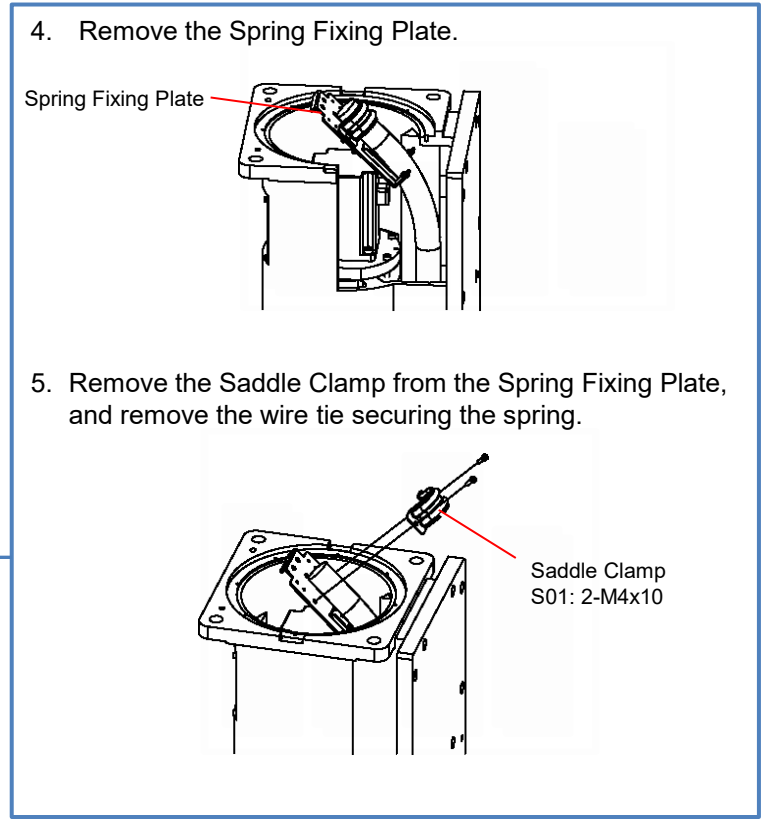
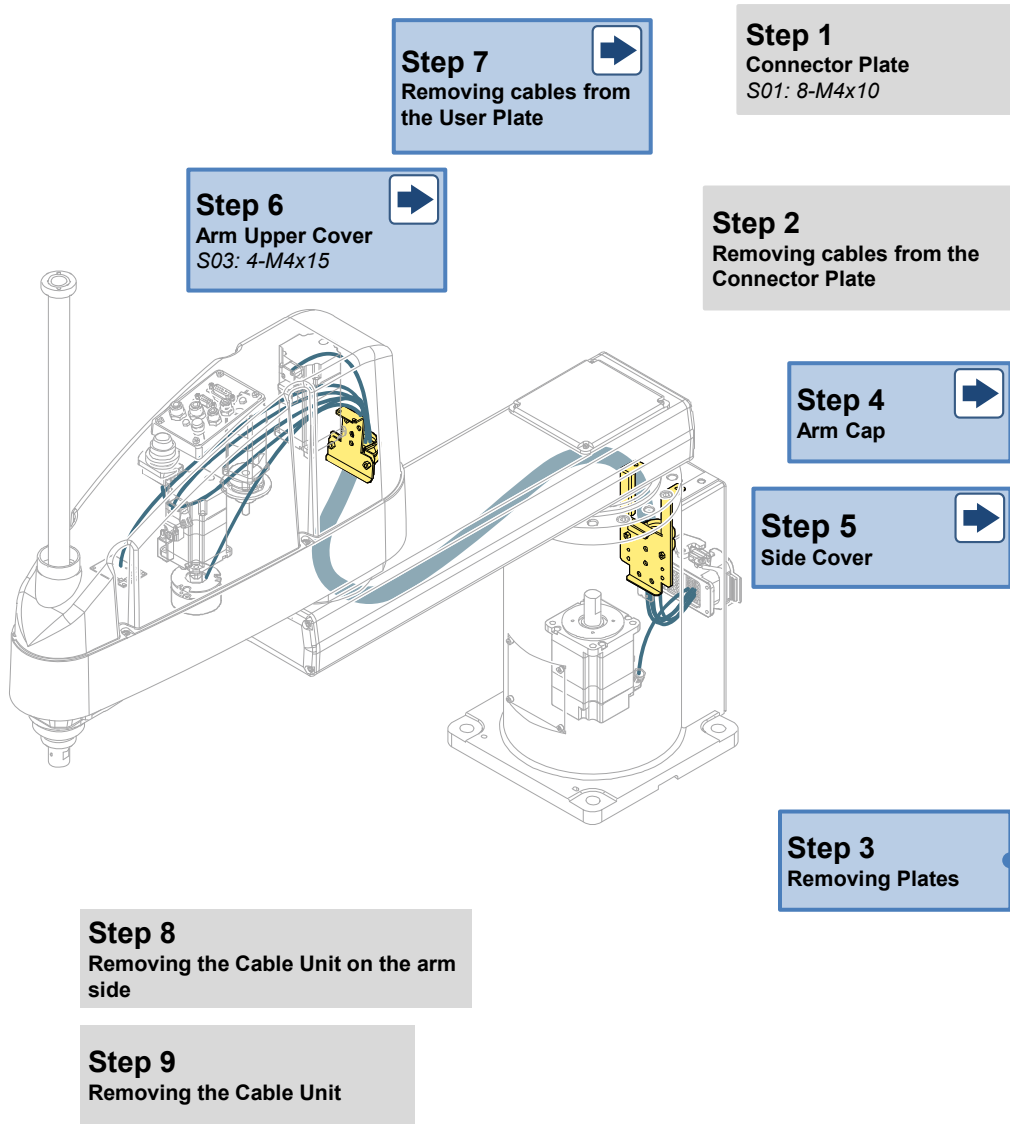

### 2.9.1 Removing the Cable Unit

**Step 7**  
Removing cables from  
the User Plate

**Step 1**  
Connector Plate  
S01: 8-M4x10

**Step 6**  
Arm Upper Cover  
S03: 4-M4x15

**Step 2**  
Removing cables from the  
Connector Plate

**Step 4**  
Arm Cap

**Step 5**  
Side Cover

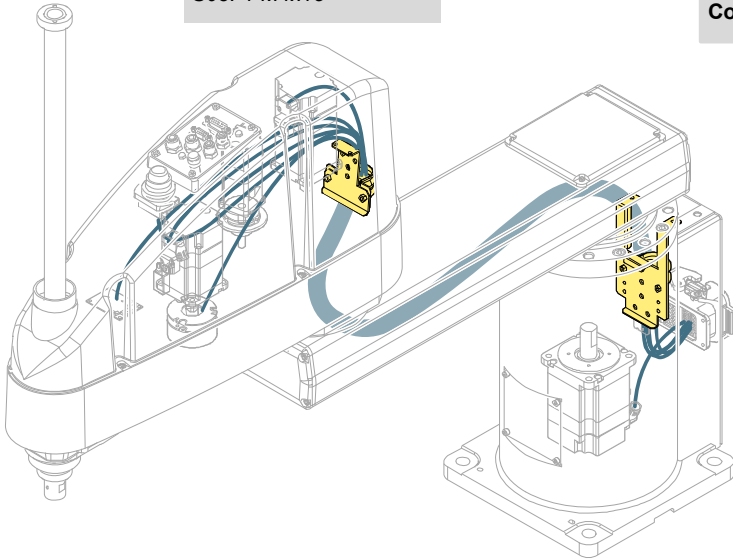

**Step 8**  
Removing the Cable Unit on the arm  
side

**Step 9**  
Removing the Cable Unit

**Disconnecting the Connectors**  
Disconnect the connectors shown in the figure.

CN121-1  
(J2 Motor Power)

CN131-1  
(J3 Motor Power)

CN141-1  
(J4 Motor Power)

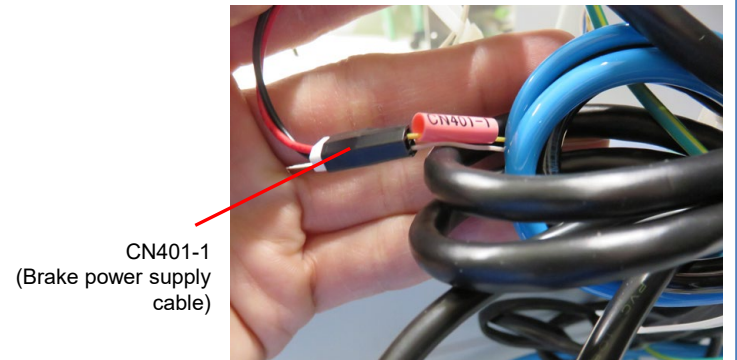
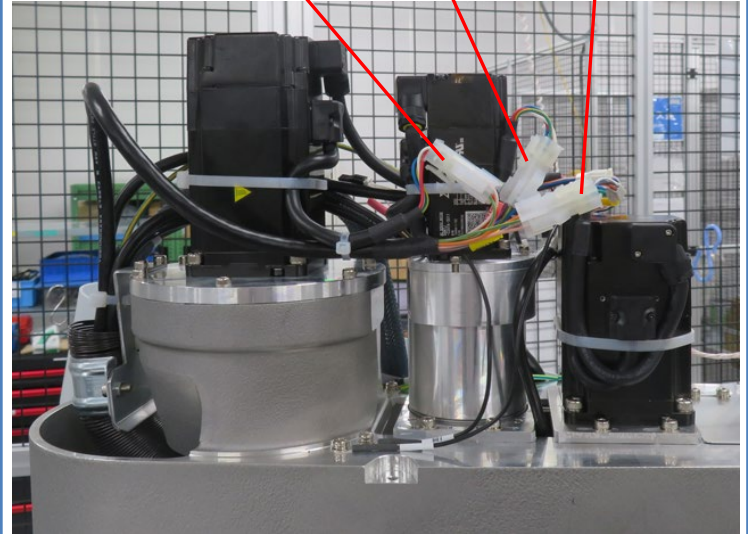

## 2.9.1 Removing the Cable Unit

**Step 7**  
Removing cables from  
the User Plate

**Step 1**  
Connector Plate  
S01: 8-M4x10

**Step 6**  
Arm Upper Cover  
S03: 4-M4x15

**Step 2**  
Removing cables from the  
Connector Plate

**Step 4**  
Arm Cap

**Step 5**  
Side Cover

### Disconnecting the Connectors

Disconnect the connectors, and remove the wire tie and Silicone Sheet shown in the figure.

- CN321-1 (J2 Motor Signal)
- CN331-1 (J3 Motor Signal)
- CN341-1 (J4 Motor Signal)
- CN3G0-1 (Control Board Cable)

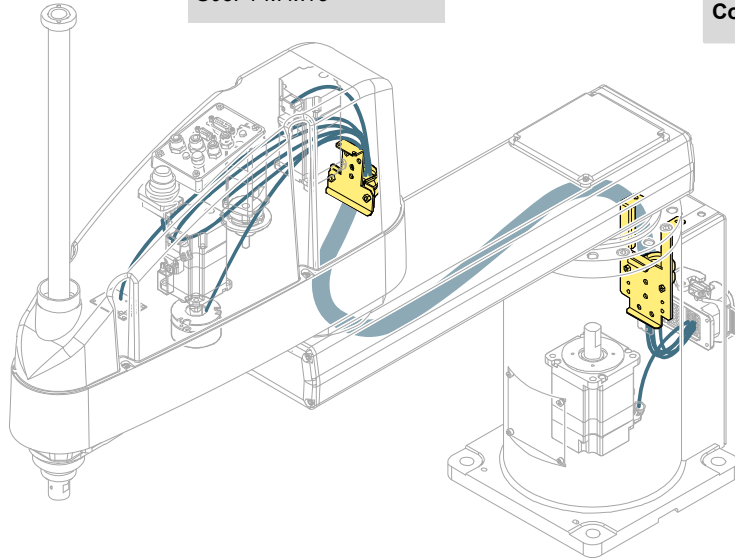
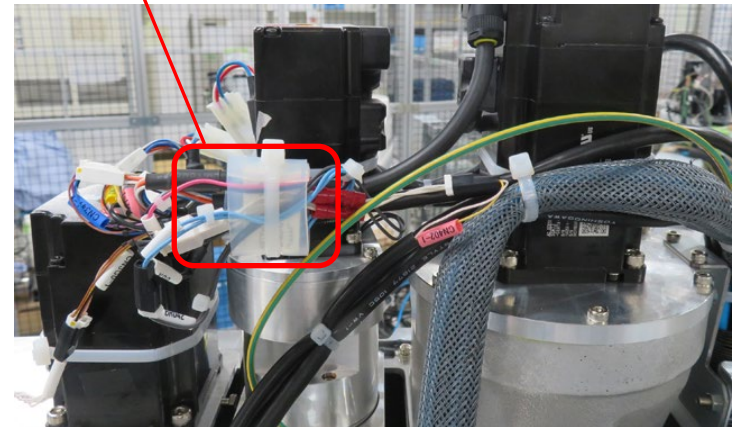

**Step 8**  
Removing the Cable Unit on the arm  
side

**Step 9**  
Removing the Cable Unit

**Step 3**  
Removing Plates



## 2.9.1 Removing the Cable Unit

**Step 7**  
Removing cables from  
the User Plate

**Step 1**  
Connector Plate  
S01: 8-M4x10

**Step 6**  
Arm Upper Cover  
S03: 4-M4x15

**Step 2**  
Removing cables from the  
Connector Plate

**Step 4**  
Arm Cap

**Step 5**  
Side Cover

**Step 3**  
Removing Plates

**Step 8**  
Removing the Cable Unit on the arm  
side

**Step 9**  
Removing the Cable Unit

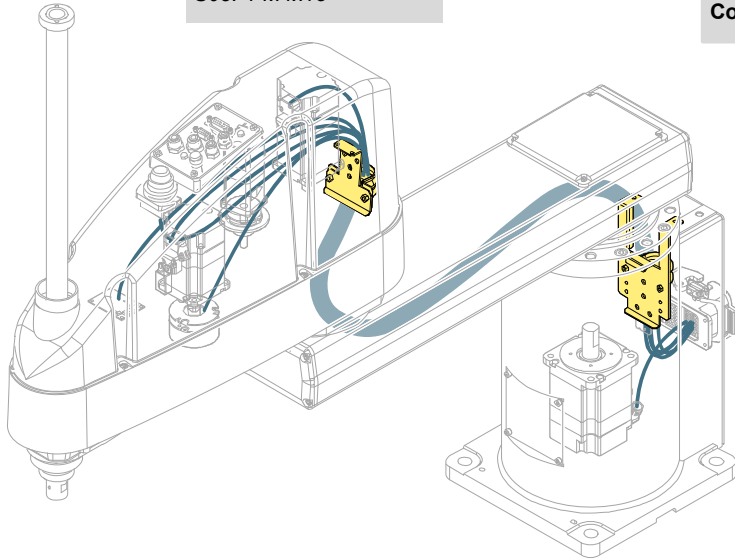

**Removing the Earth Terminal**  
Remove the earth cable secured to Arm2.

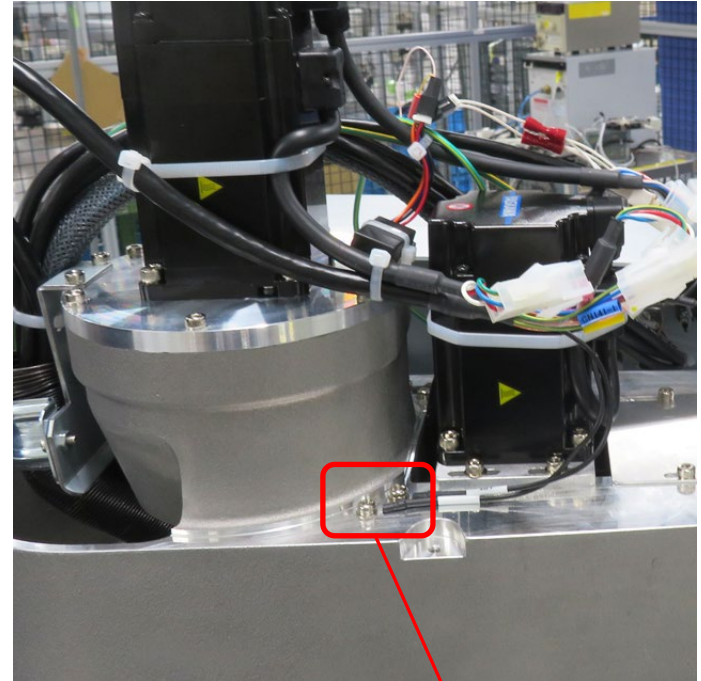

FB6, FB7

## 2.9.1 Removing the Cable Unit

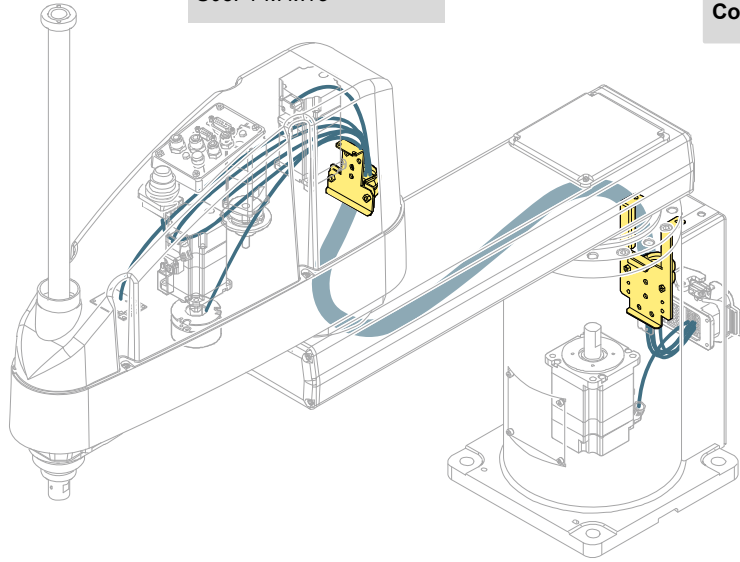

**Step 1**  
Connector Plate  
S01: 8-M4x10

**Step 2**  
Removing cables from the Connector Plate

**Step 3**  
Removing Plates

**Step 4**  
Arm Cap

**Step 5**  
Side Cover

**Step 6**  
Arm Upper Cover  
S03: 4-M4x15

**Step 7**  
Removing cables from the User Plate

**Step 8**  
Removing the Cable Unit on the arm side

**Step 9**  
Removing the Cable Unit

**Removing the Saddle Clamp and Spring Fixing Plate**  
Remove the Saddle Clamp secured to Arm2 and remove the Spring Fixing Plate.

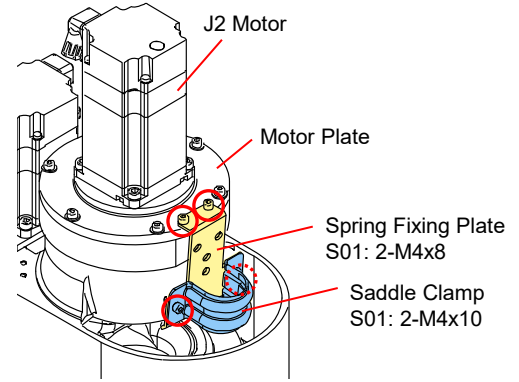

Remove the wire tie from the cable.

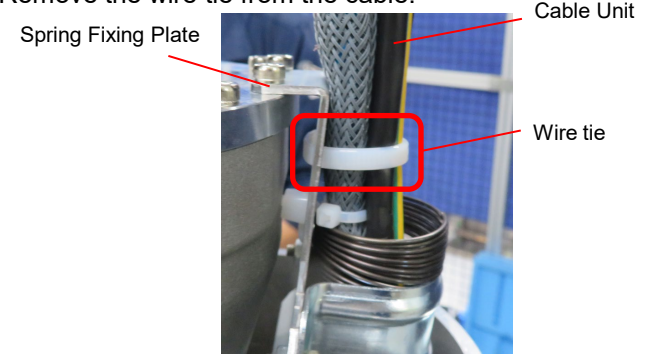

**Removing the Spring Fixing Plate**  
Remove the anchor bolts of the Spring Fixing Plate.

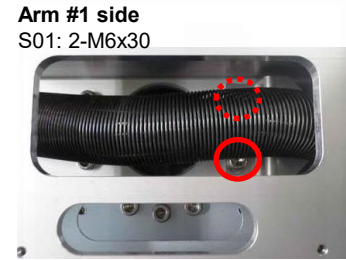



## 2.9.1 Removing the Cable Unit

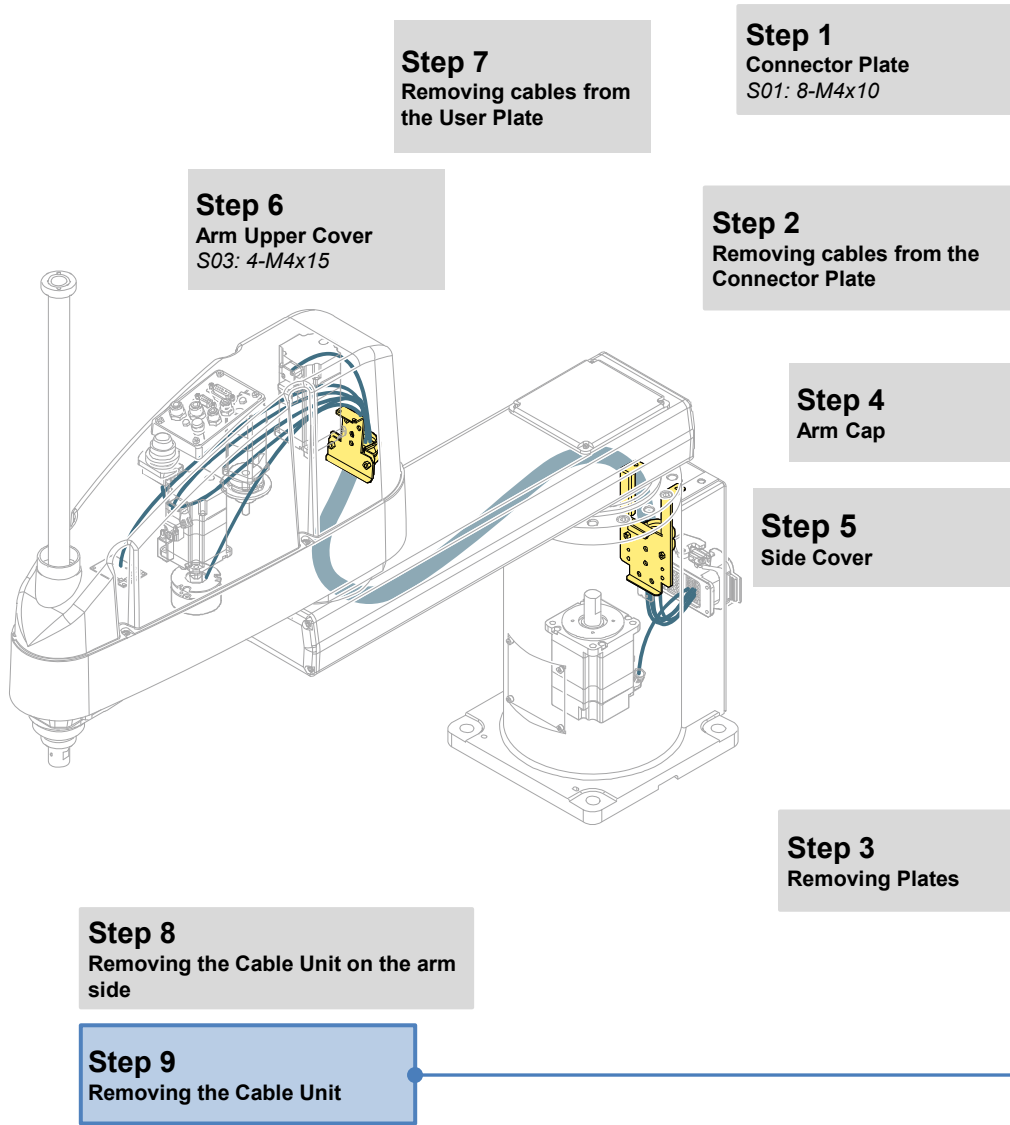

### Removing the Cable Unit on the Base Side

**CAUTION**

When disconnecting cables, be sure to remove the Air Tube first. Next, remove the cables with smaller connectors first. If an attempt is made to disconnect a cable by using excessive force, the connector may get caught, wires may be broken, and connector pins may become bent or broken.

1. Disconnect the cable from the base, and remove it from the Cap Cover opening of Arm1.
2. Remove the cables from the Cap Cover opening or from the Side Cover opening.

**Procedure**

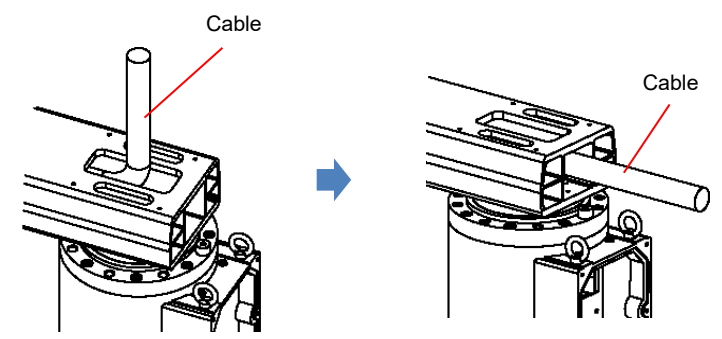

## 2.9.1 Removing the Cable Unit

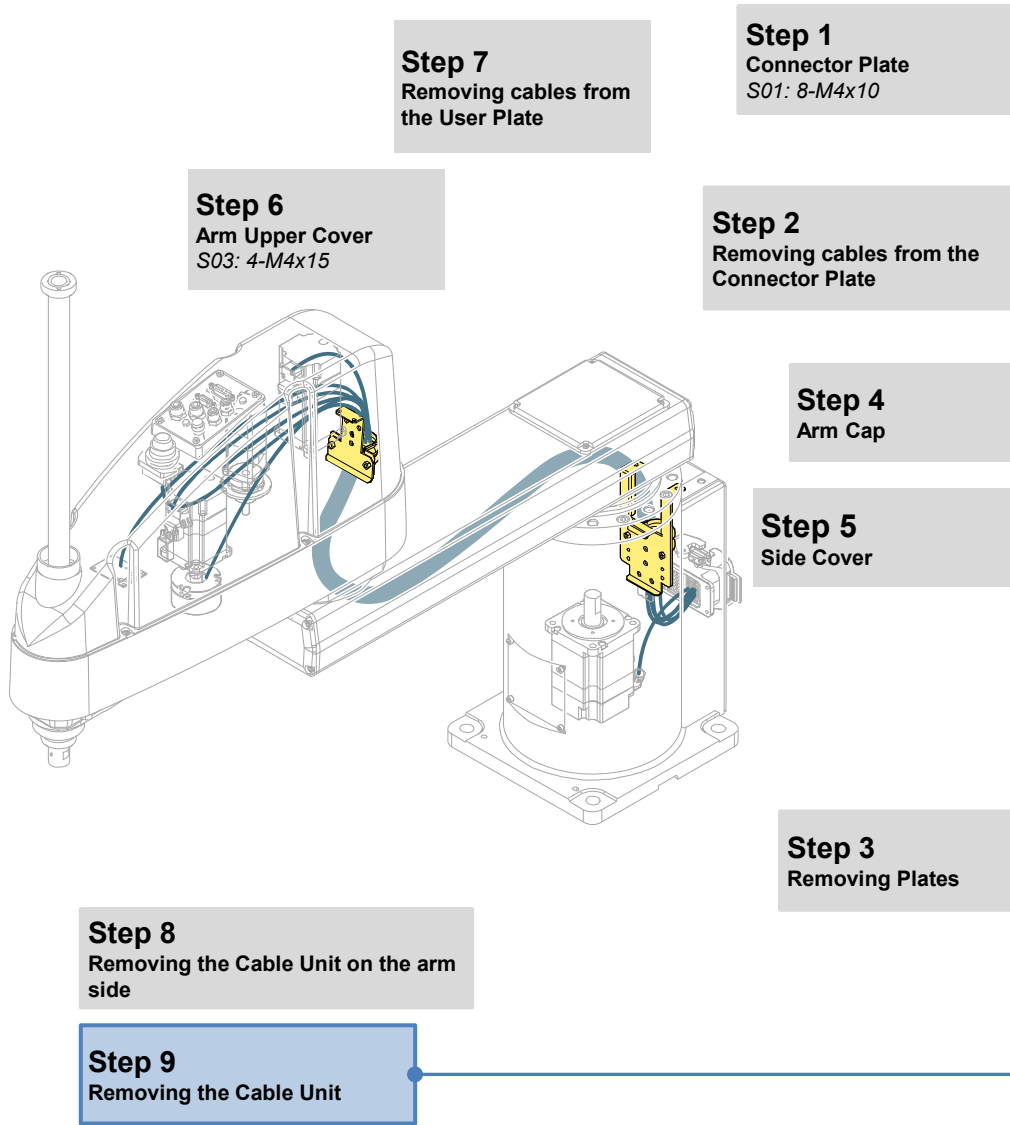

### Removing the Cable Unit on the Arm2 Side

**CAUTION**

When disconnecting cables, be sure to remove the Air Tube first. Next, remove the cables with smaller connectors first. If an attempt is made to disconnect a cable by using excessive force, the connector may get caught, wires may be broken, and connector pins may become bent or broken.

1. Disconnect the cable from Arm2, and remove it from the Cap Cover opening of Arm1.
2. Remove the cables from the Cap Cover opening or from the Side Cover opening.

**Procedure**

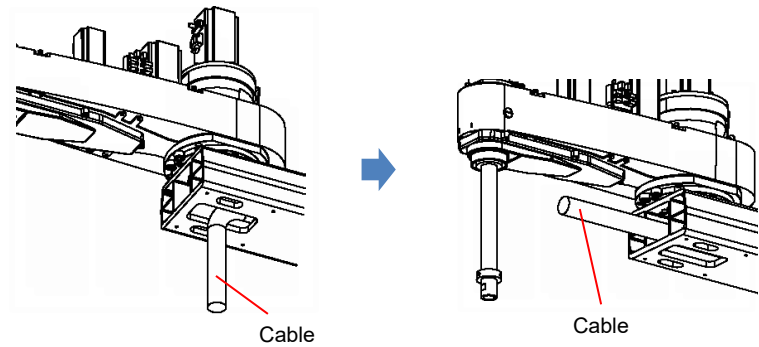

**Cable Unit**



## 2.9.2 Installing the Cable Unit

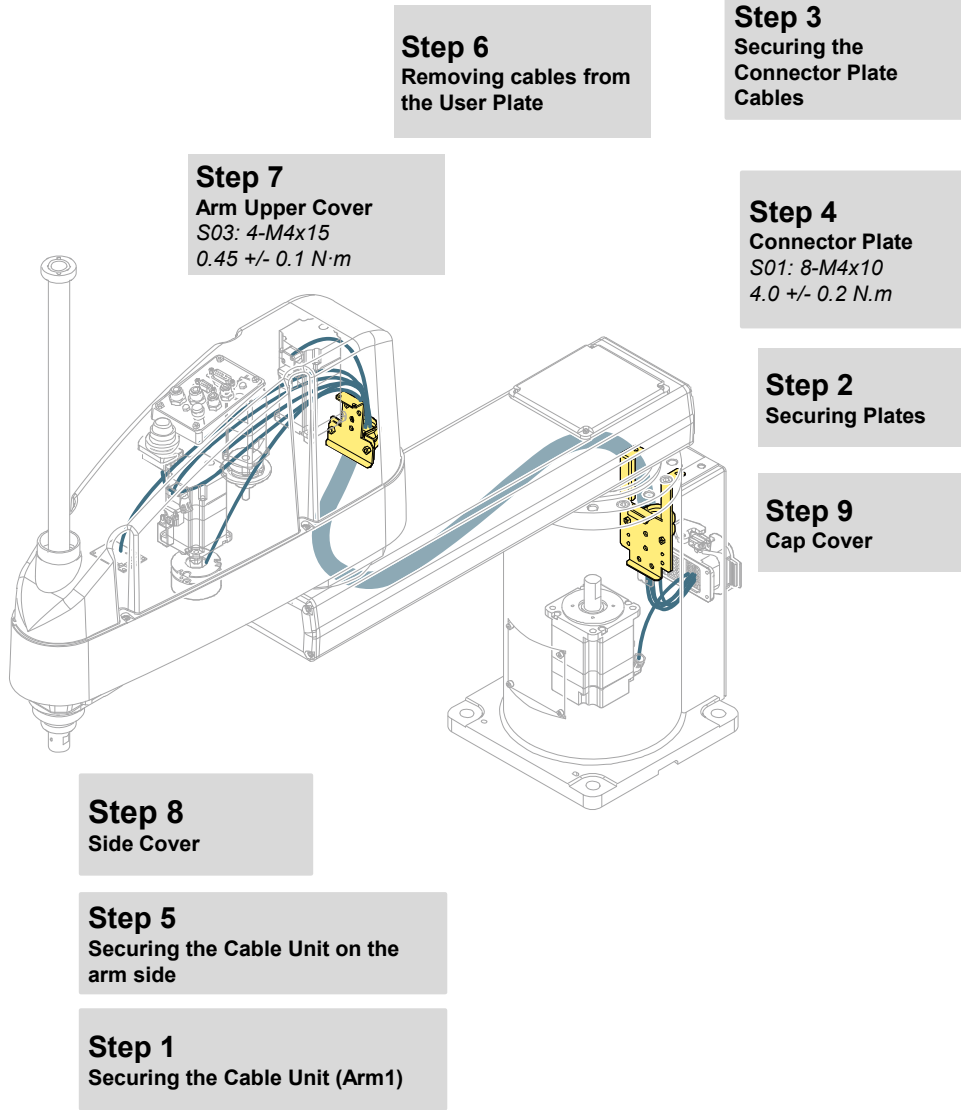

**CAUTION**

- When attaching the Cable Unit to the Manipulator, take care that the connectors and bracket do not get caught.
- Replace the cables as a unit, not individually.

### Preparation

**1. Applying grease to cables**  
Apply grease to the locations shown in the figure.  
Greasing locations: Cables inside the spring, Air Tube, outer periphery of spring (shaded part)

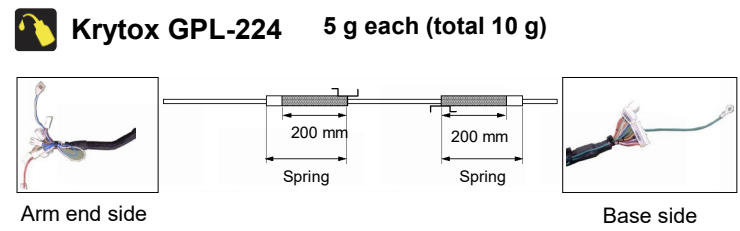

**2. Protecting connectors and Air Tube**  
During routing of the cables, cover the end of the cables with plastic bags to prevent grease applied to the cables from adhering to connectors and the ends of the Air Tube.



## 2.9.2 Installing the Cable Unit

**Step 6**  
Removing cables from  
the User Plate

**Step 3**  
Securing the  
Connector Plate  
Cables

**Step 7**  
Arm Upper Cover  
S03: 4-M4x15  
0.45 +/- 0.1 N·m

**Step 4**  
Connector Plate  
S01: 8-M4x10  
4.0 +/- 0.2 N·m

**Step 2**  
Securing Plates

**Step 9**  
Cap Cover

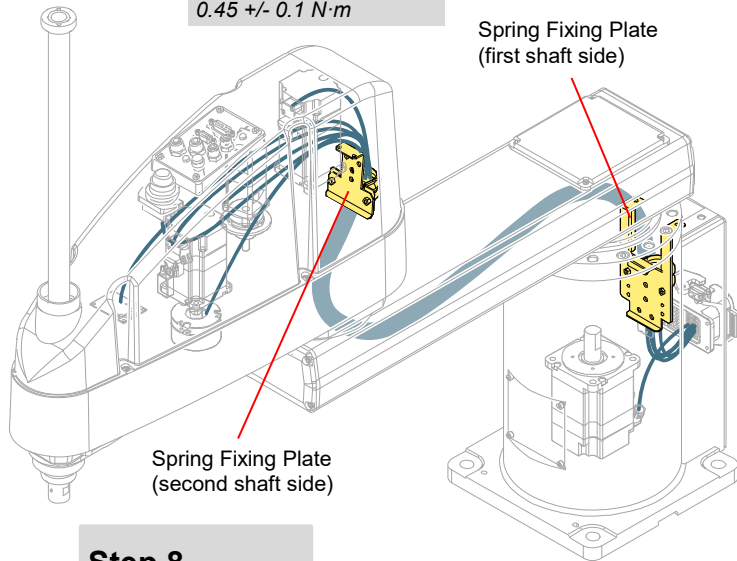

**Step 8**  
Side Cover

**Step 5**  
Securing the Cable Unit on the  
arm side

**Step 1**  
Securing the Cable Unit (Arm1)

Insert the cable into Arm1.

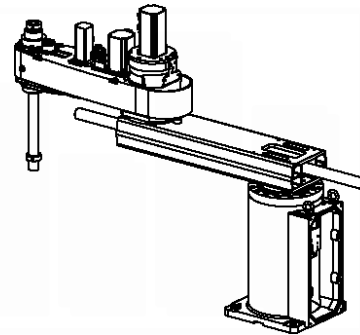

Secure the Spring Fixing Plate on Arm1.

**Arm #1 side**  
S01: 2-M6x30  
13.0 +/- 0.6 N.m

**Arm #2 side**  
S01: 2-M5x18  
8.0 +/- 0.4 N.m



## 2.9.2 Installing the Cable Unit

**Step 6**  
Removing cables from the User Plate

**Step 3**  
Securing the Connector Plate Cables

**Step 7**  
Arm Upper Cover  
S03: 4-M4x15  
0.45 +/- 0.1 N·m

**Step 4**  
Connector Plate  
S01: 8-M4x10  
4.0 +/- 0.2 N·m

**Step 2**  
Securing Plates

**Step 9**  
Cap Cover

**Step 8**  
Side Cover

**Step 5**  
Securing the Cable Unit on the arm side

**Step 1**  
Securing the Cable Unit (Arm1)

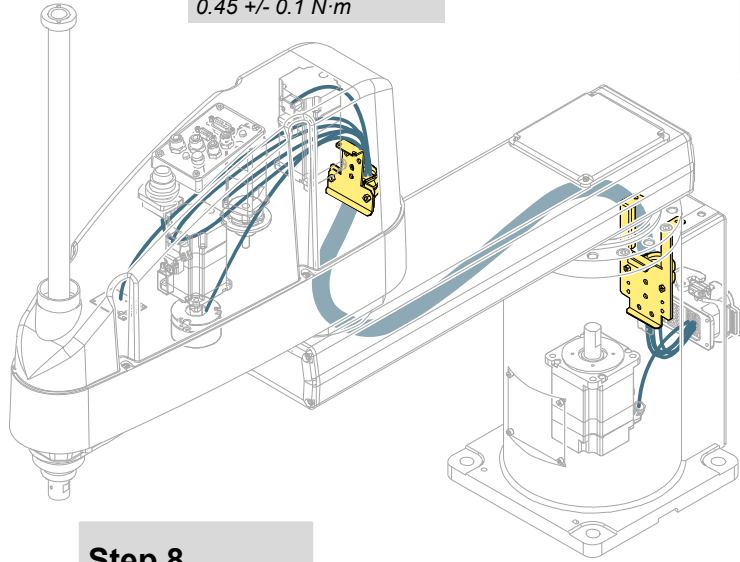

Remove the cable on the base side from the upper side of Arm1 and draw the cable into the base.

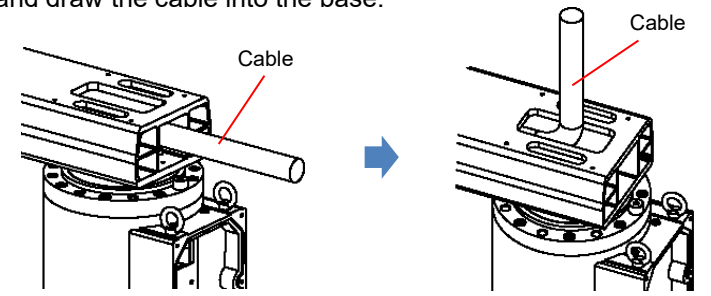

Secure the Spring Fixing Plate.

### Table Top Mounting Type/Ceiling Mounting Type

1. Secure the spring for protecting the cable to the Spring Fixing Plate with a wire tie.

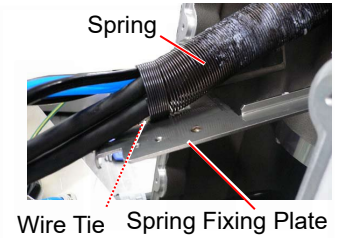

2. Secure the Spring Fixing Plate to the motor unit and the base.

S01: 2-M4x15  
4.0 +/- 0.2 N·m

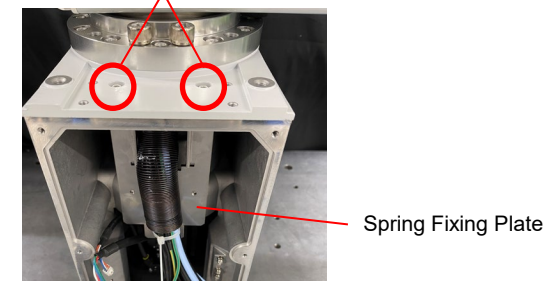

## 2.9.2 Installing the Cable Unit

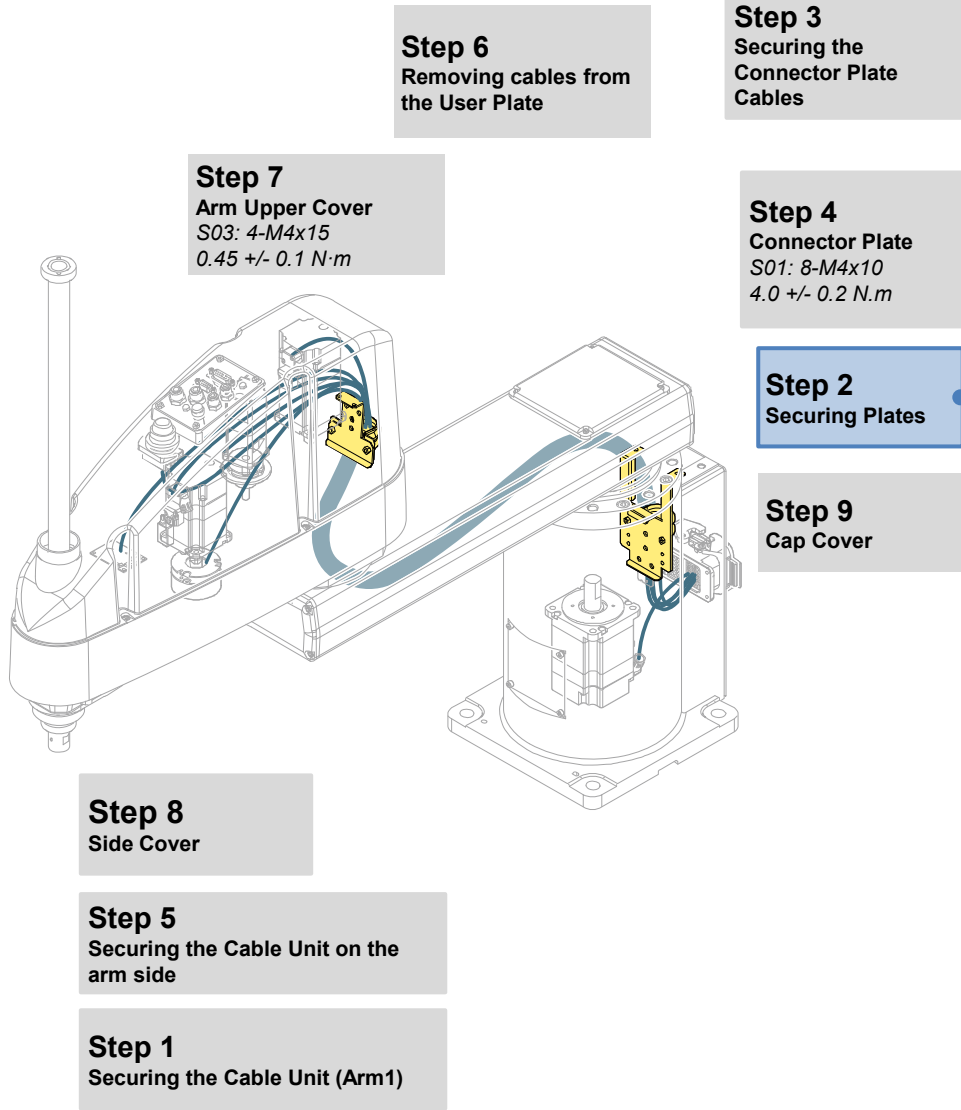

3. Move Arm1 until it comes into contact with either the left or right mechanical stopper.  
With sufficient slack provided on the cable, secure the cable and Air Tube with a wire tie.

**CAUTION**

If the cable and Air Tube are secured with insufficient slack provided, the cable might be pulled and the cable line might become disconnected during operation. Be sure to provide sufficient slack.

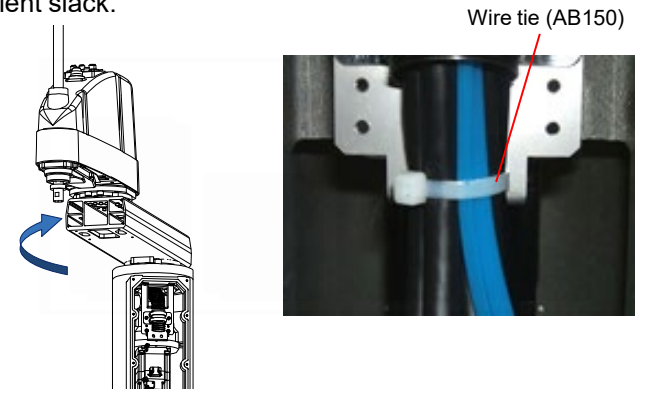

4. Remove the plastic bag at the base side of the Cable Unit.
5. Attach the Saddle Clamp and FB cable to the Spring Fixing Plate.

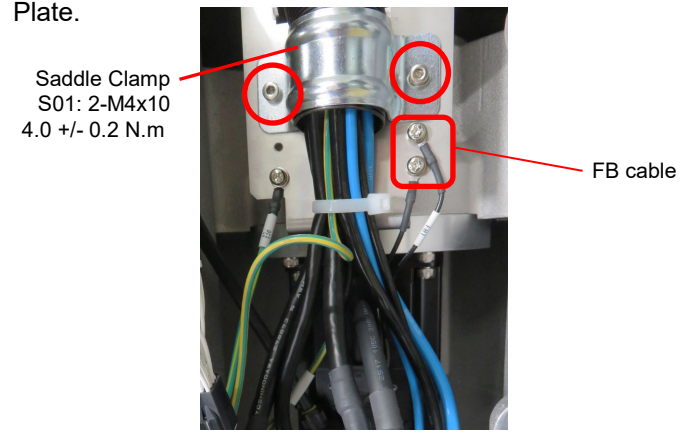



## 2.9.2 Installing the Cable Unit

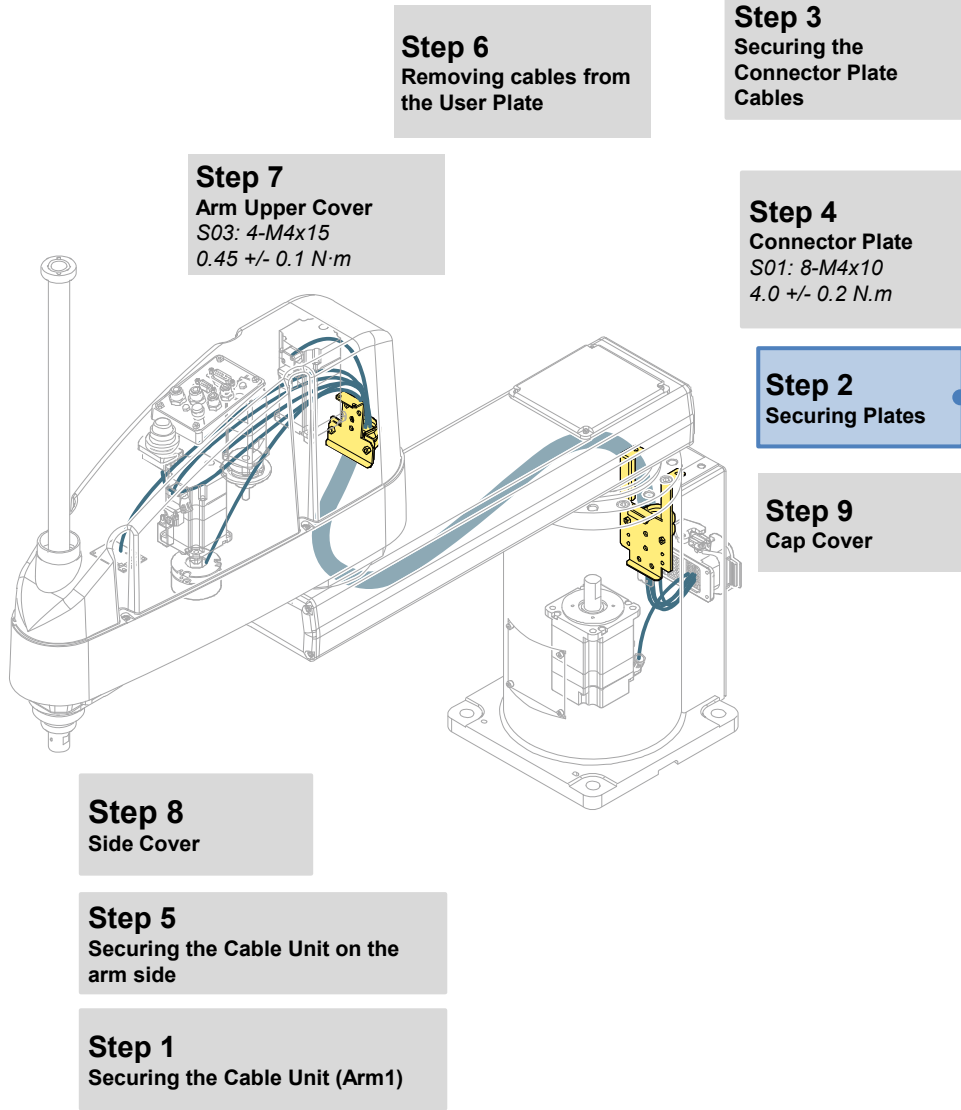

### Wall Mounting Type

1. Remove the spring, and secure the spring to the Spring Fixing Plate with a wire tie.

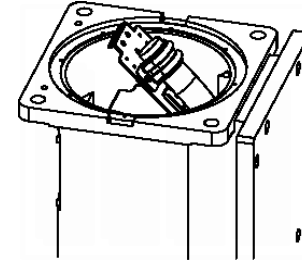

2. Install the Saddle Clamp securing the cable.

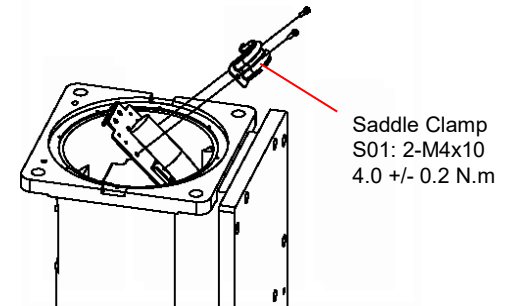

3. Temporarily secure the cable with the wire tie. Ensure that the cable is free to move.

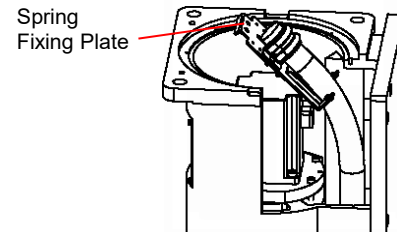



## 2.9.2 Installing the Cable Unit

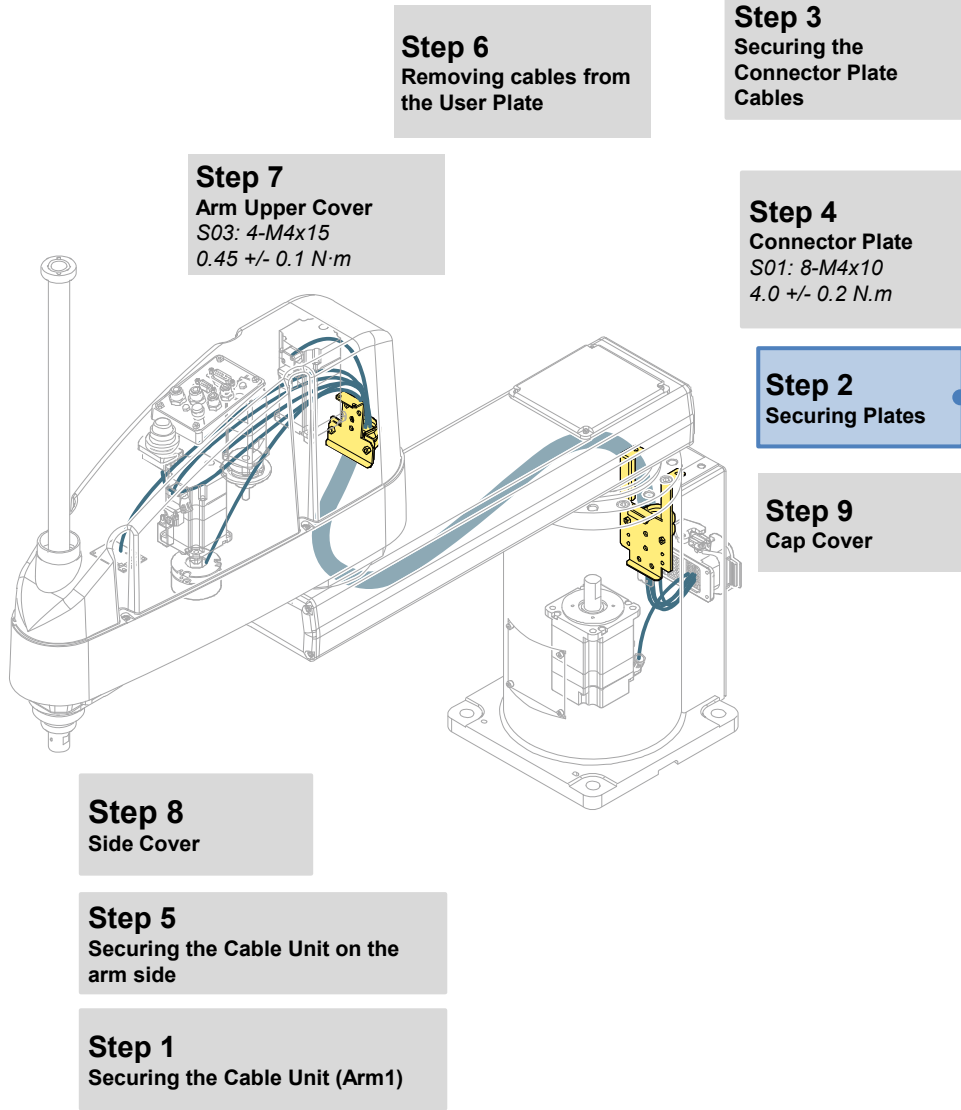

4. Move Arm1 until it comes into contact with either the left or right mechanical stopper, and with sufficient slack provided on the cable, secure the cable and Air Tube with a wire tie.

**CAUTION**

Be sure to provide sufficient slack. If the cable and Air Tube are secured with insufficient slack provided, the cable might be pulled and the cable line might become disconnected during operation.

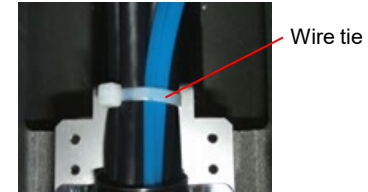

5. Remove the plastic bag at the base side of the Cable Unit.
6. Secure the Spring Fixing Plate.

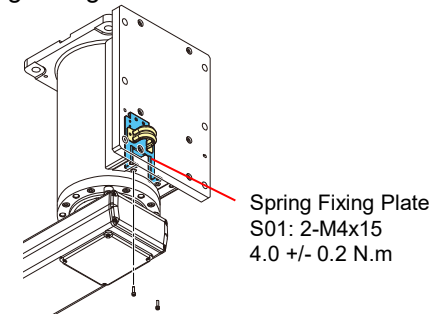

7. Secure the Ground Plate.

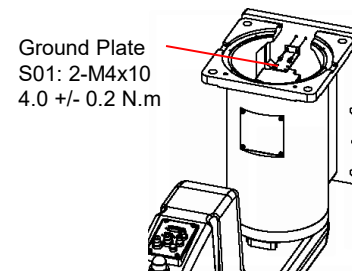

## 2.9.2 Installing the Cable Unit

**Step 6**  
Removing cables from  
the User Plate

**Step 3**  
Securing the  
Connector Plate  
Cables

**Step 7**  
Arm Upper Cover  
S03: 4-M4x15  
0.45 +/- 0.1 N·m

**Step 4**  
Connector Plate  
S01: 8-M4x10  
4.0 +/- 0.2 N.m

**Step 2**  
Securing Plates

**Step 9**  
Cap Cover

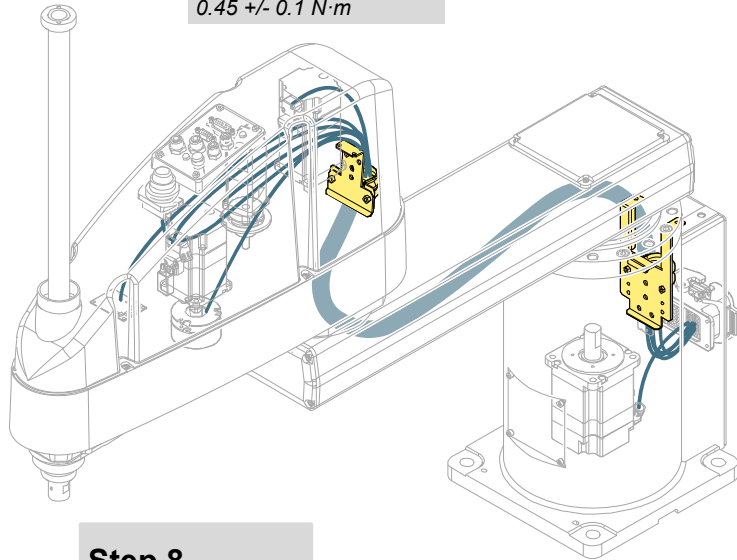

**Step 8**  
Side Cover

**Step 5**  
Securing the Cable Unit on the  
arm side

**Step 1**  
Securing the Cable Unit (Arm1)

Remove the cable on the Arm2 side to the lower side of Arm1, then draw the cable into Arm2.

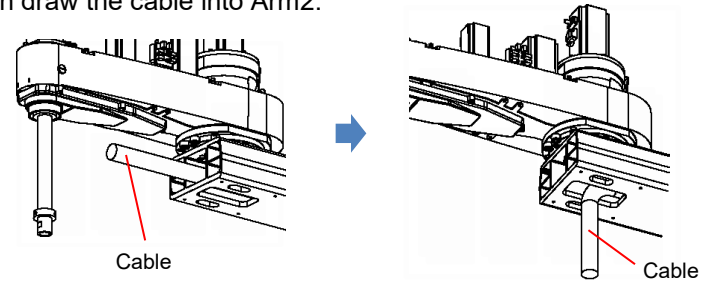

Secure the spring for protecting the cable to the Spring Fixing Plate with a wire tie.  
Secure the Spring Fixing Plate on Arm2.

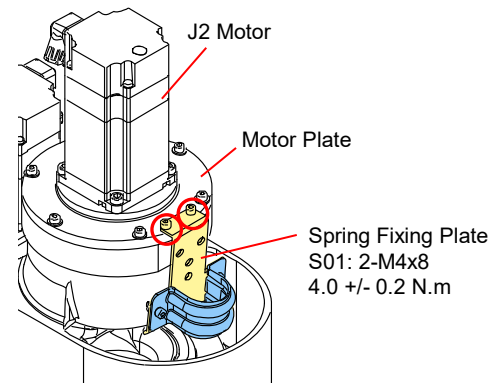

## 2.9.2 Installing the Cable Unit

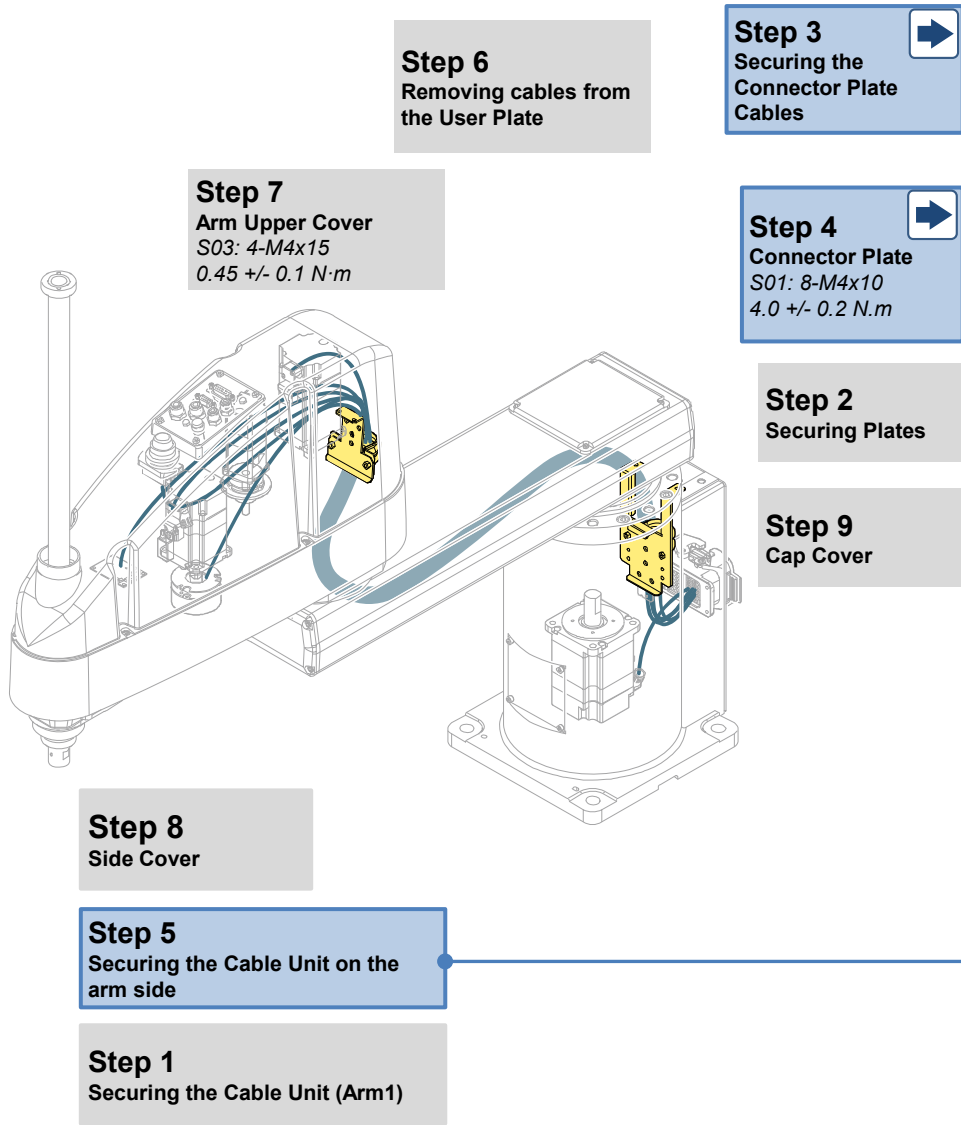

Move Arm2 until it comes into contact with the mechanical stopper, and with sufficient slack provided on the cable, secure the cable and Air Tube with a wire tie.

### CAUTION

Be sure to provide sufficient slack. If the cable and Air Tube are secured with insufficient slack provided, the cable might be pulled and the cable line might become disconnected during operation.

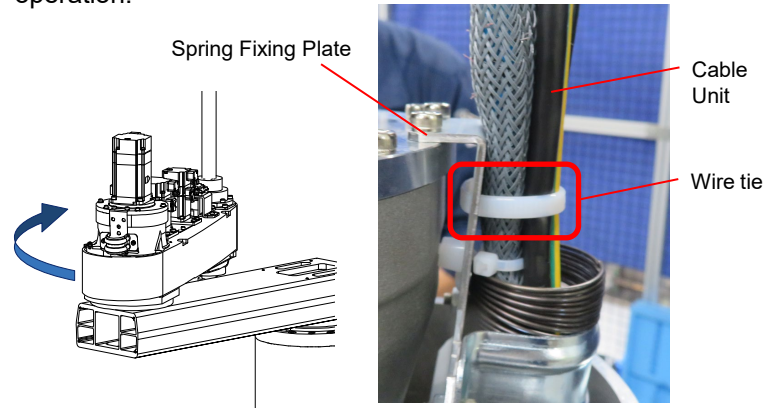

Remove the plastic bag at the arm side of the Cable Unit.

Attach the Saddle Clamp to the Spring Fixing Plate.

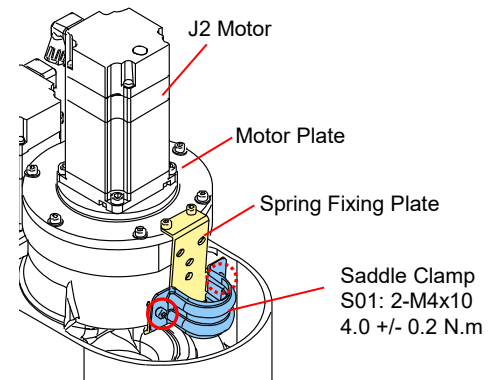

## 2.9.2 Installing the Cable Unit

**Step 6**  
Removing cables from  
the User Plate

**Step 3**  
Securing the  
Connector Plate  
Cables

**Step 7**  
Arm Upper Cover  
S03: 4-M4x15  
0.45 +/- 0.1 N·m

**Step 4**  
Connector Plate  
S01: 8-M4x10  
4.0 +/- 0.2 N.m

**Step 2**  
Securing Plates

**Step 9**  
Cap Cover

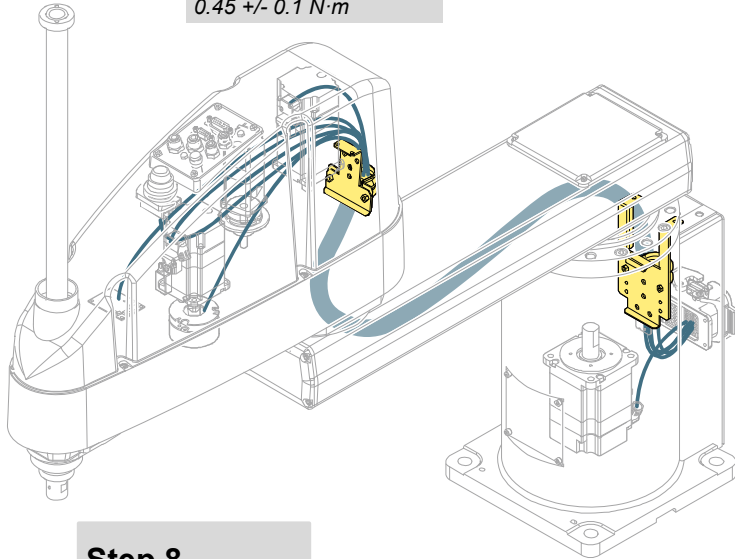

**Step 8**  
Side Cover

**Step 5**  
Securing the Cable Unit on the  
arm side

**Step 1**  
Securing the Cable Unit (Arm1)

**Installing the Earth Terminal**  
Secure the earth cable to Arm2.

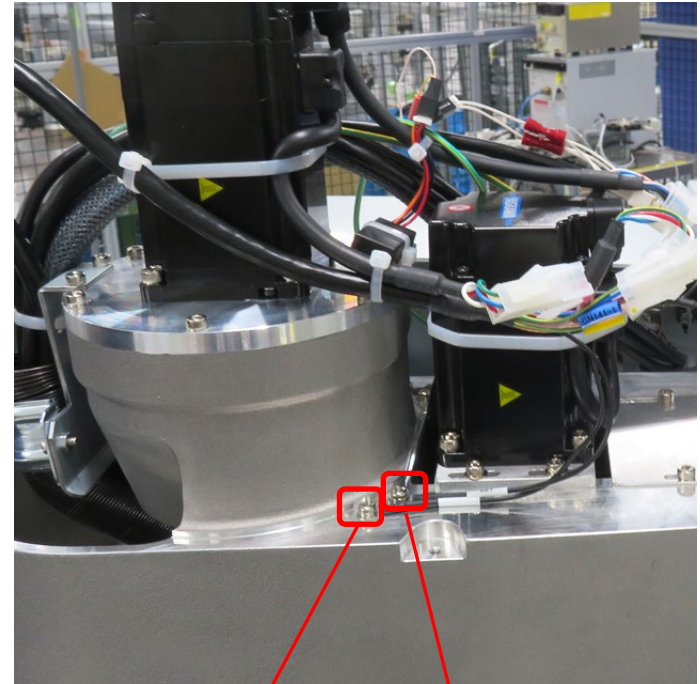

FB7  
S04: 1-M4x6  
0.9 +/- 0.1 N.m

FB6  
S04: 1-M4x6  
0.9 +/- 0.1 N.m

## 2.9.2 Installing the Cable Unit

**Step 6**  
Removing cables from the User Plate

**Step 3**  
Securing the Connector Plate Cables

**Step 7**  
Arm Upper Cover  
S03: 4-M4x15  
0.45 +/- 0.1 N·m

**Step 4**  
Connector Plate  
S01: 8-M4x10  
4.0 +/- 0.2 N.m

**Step 2**  
Securing Plates

**Step 9**  
Cap Cover

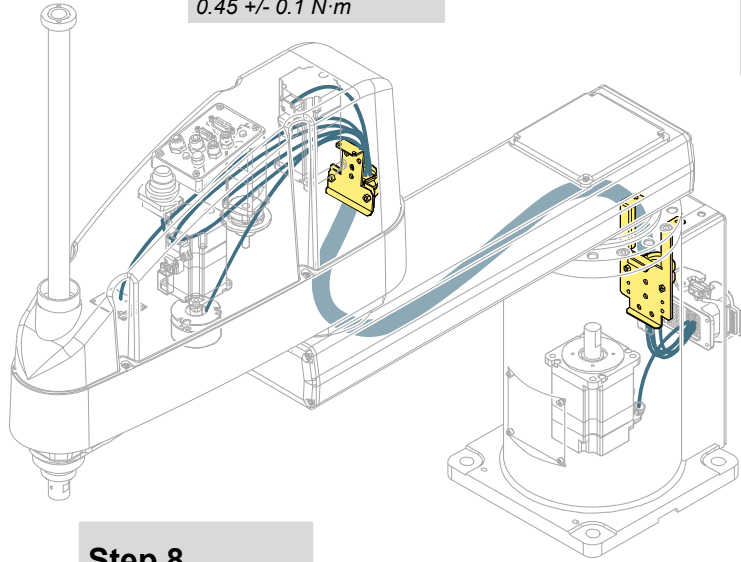

**Step 8**  
Side Cover

**Step 5**  
Securing the Cable Unit on the arm side

**Step 1**  
Securing the Cable Unit (Arm1)

**Connecting the Motor Unit Connectors**  
Wrap CN321-1/CN331-1/CN400-2/CN402-1 with the Silicone Sheet together with the other connectors and cables, and secure them with a wire tie (AB150).

**CAUTION**  
Take care not to apply a load to the cables, for example, by bending the cables with excessive force.

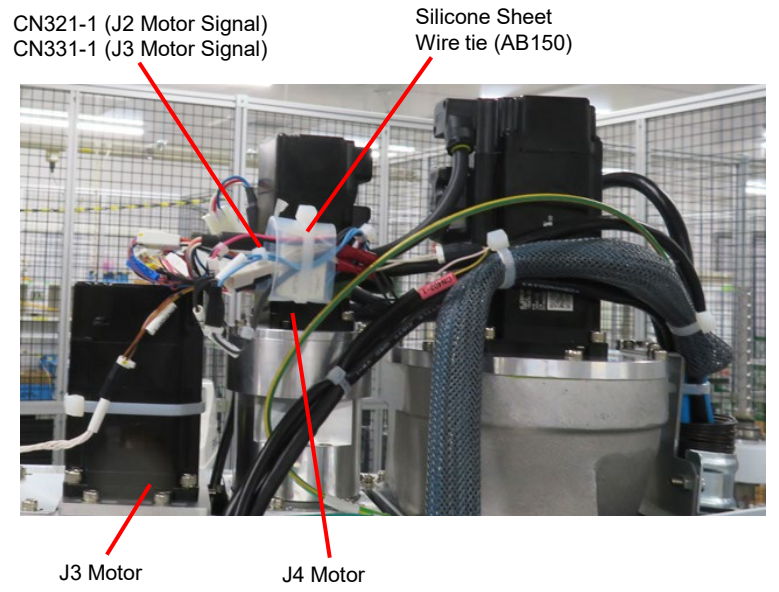



## 2.9.2 Installing the Cable Unit

**Step 6**  
Removing cables from  
the User Plate

**Step 3**  
Securing the  
Connector Plate  
Cables

**Step 7**  
Arm Upper Cover  
S03: 4-M4x15  
0.45 +/- 0.1 N·m

**Step 4**  
Connector Plate  
S01: 8-M4x10  
4.0 +/- 0.2 N·m

**Step 2**  
Securing Plates

**Step 9**  
Cap Cover

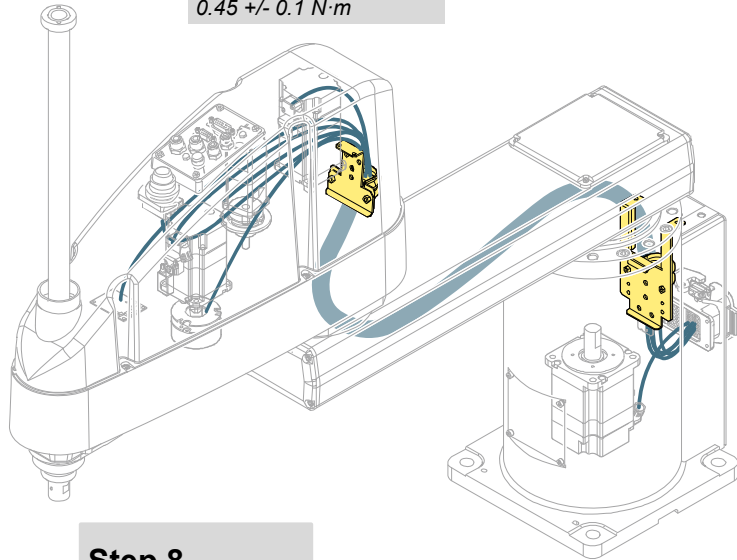

**Step 8**  
Side Cover

**Step 5**  
Securing the Cable Unit on the  
arm side

**Step 1**  
Securing the Cable Unit (Arm1)

### Connecting the Motor Unit Connectors

CN341-1 (J4 Motor Signal)  
CN440-1 (J4 Brake)  
Silicone Sheet, Wire tie (AB150) J4 Motor

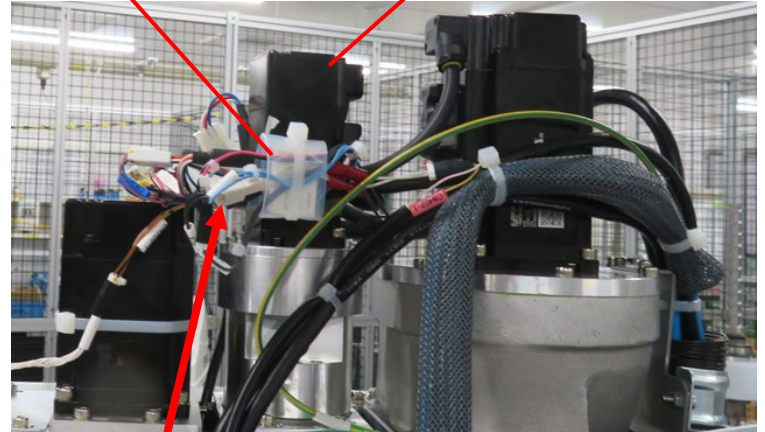

Tie the connectors  
shown in the figure.

CN341-1  
(J4 Motor Signal)

CN3G0-2  
(Control Board Cable)

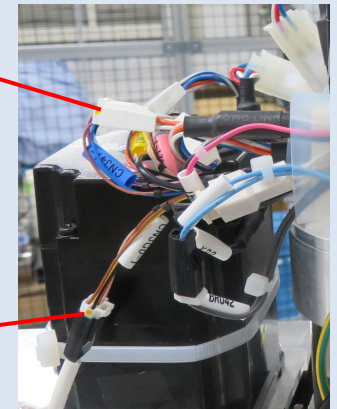

## 2.9.2 Installing the Cable Unit

**Step 6**  
Removing cables from  
the User Plate

**Step 7**  
Arm Upper Cover  
S03: 4-M4x15  
0.45 +/- 0.1 N·m

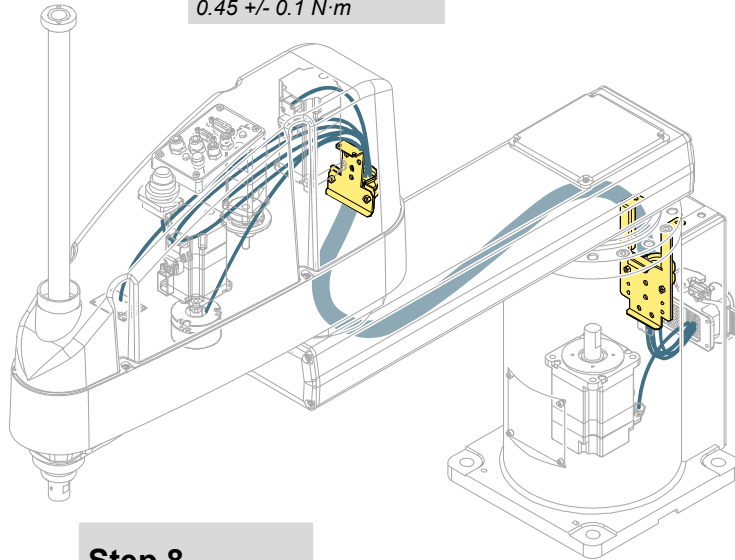

**Step 3**  
Securing the  
Connector Plate  
Cables

**Step 4**  
Connector Plate  
S01: 8-M4x10  
4.0 +/- 0.2 N.m

**Step 2**  
Securing Plates

**Step 9**  
Cap Cover

**Step 8**  
Side Cover

**Step 5**  
Securing the Cable Unit on the  
arm side

**Step 1**  
Securing the Cable Unit (Arm1)

### Connecting the Connectors

Connect the connectors shown in the figure.

CN121-1  
(J2 Motor Power)

CN131-1  
(J3 Motor Power)

CN141-1  
(J4 Motor Power)

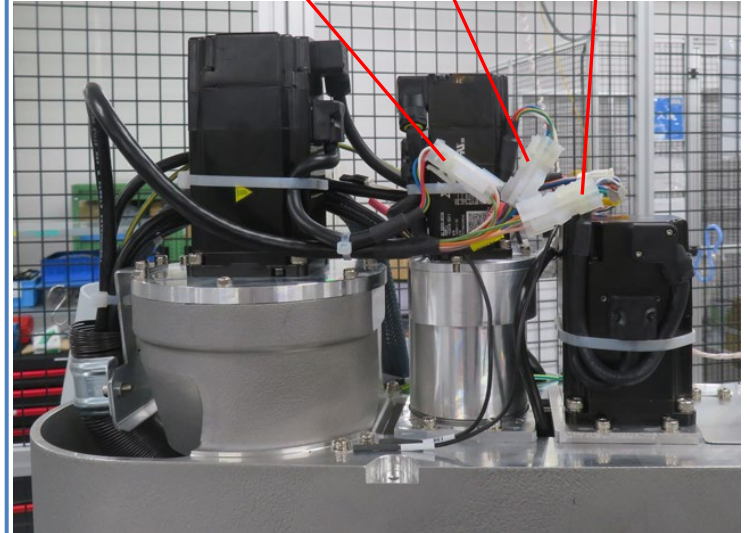

CN401-1  
(Brake power supply  
cable)

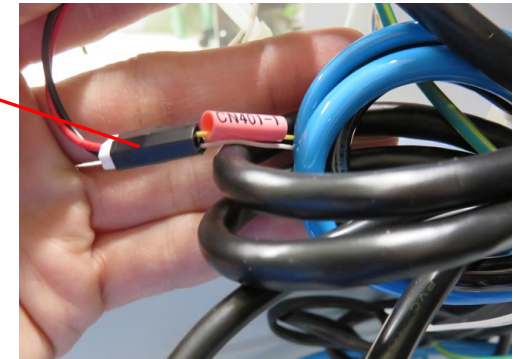



## 2.9.2 Installing the Cable Unit

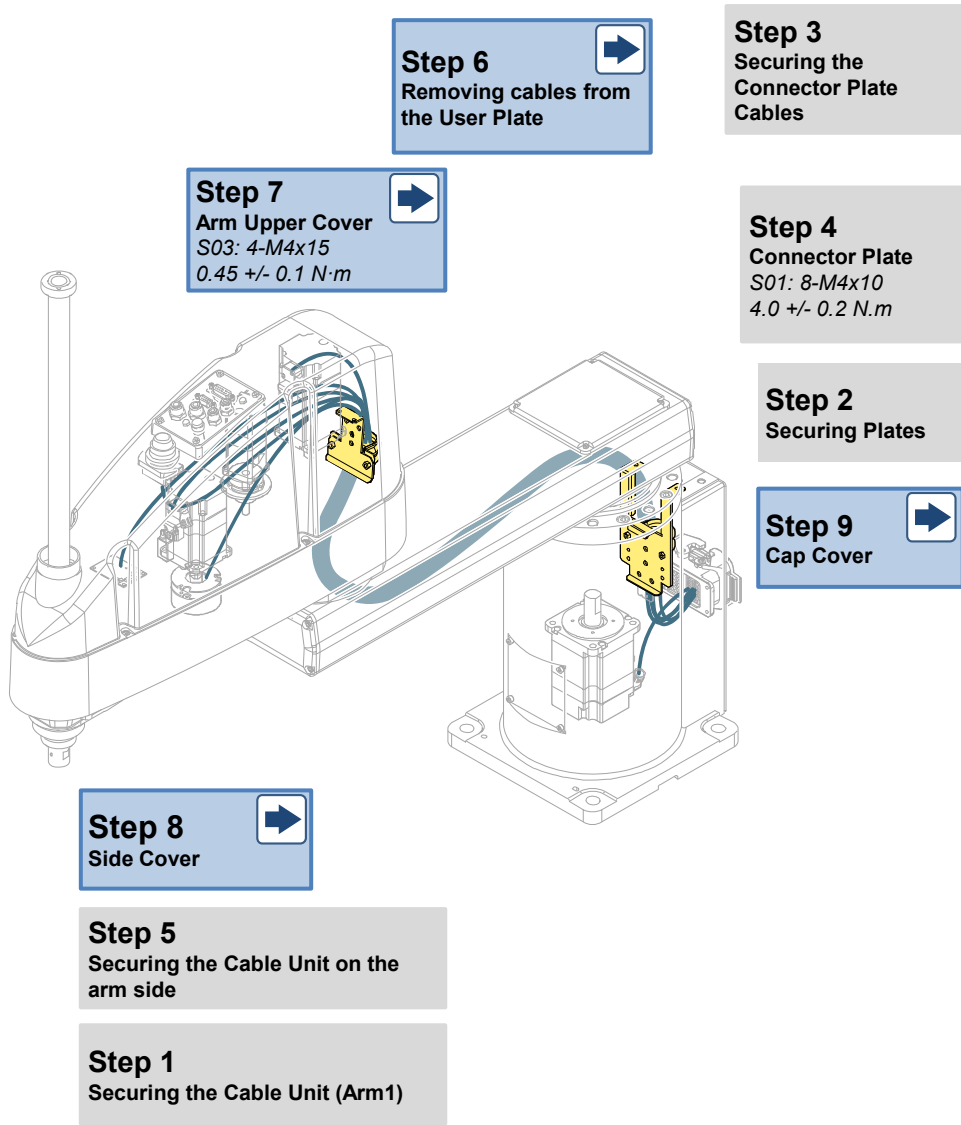

## 2.10 Installing/Removing the Cover

GX20 has the following covers and plates.

The contents to be particularly noted during maintenance, and the covers and plates for which the cables need to be removed or connected are described in detail on the next page and thereafter.

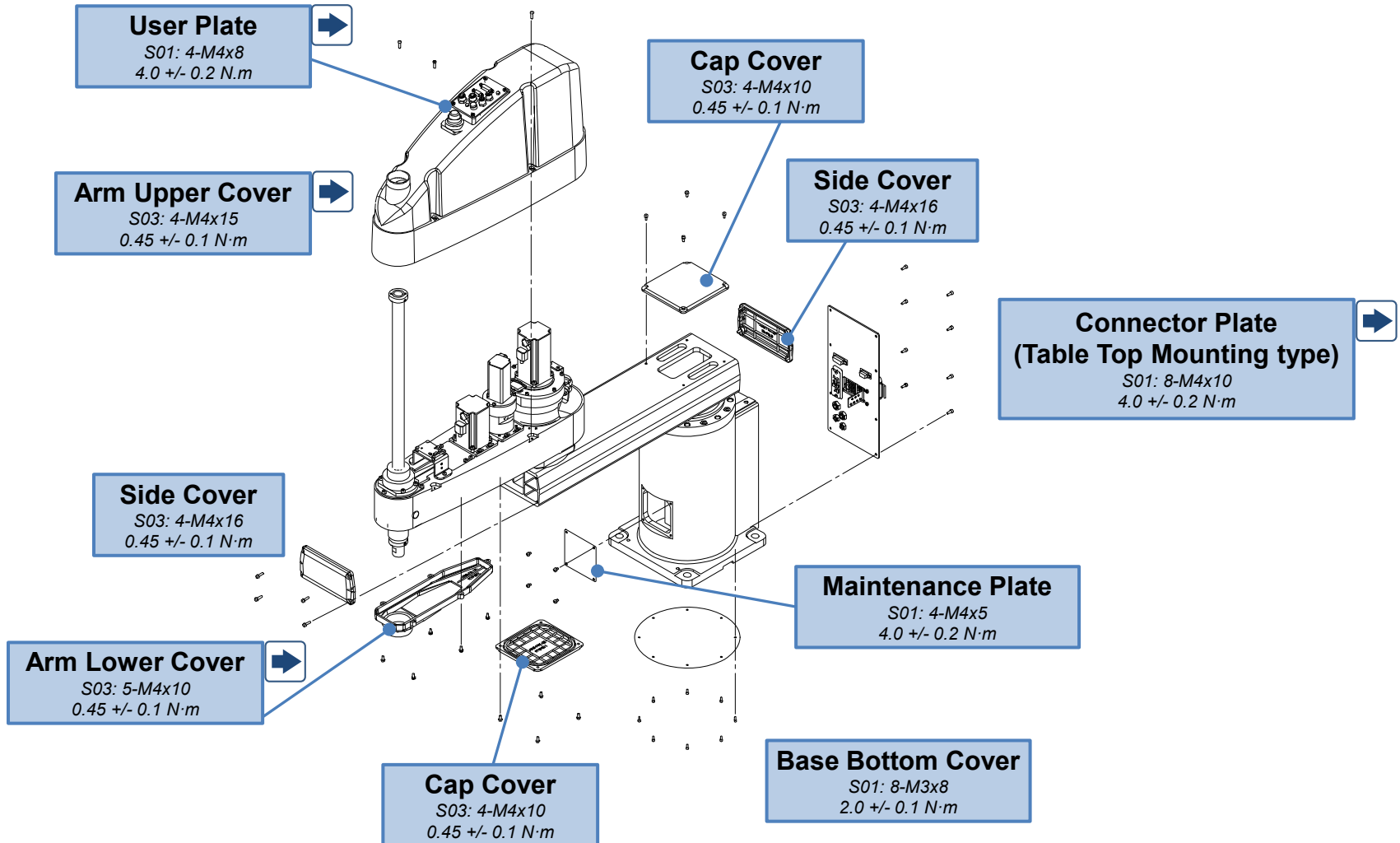

## 2.10.1 Arm Upper Cover

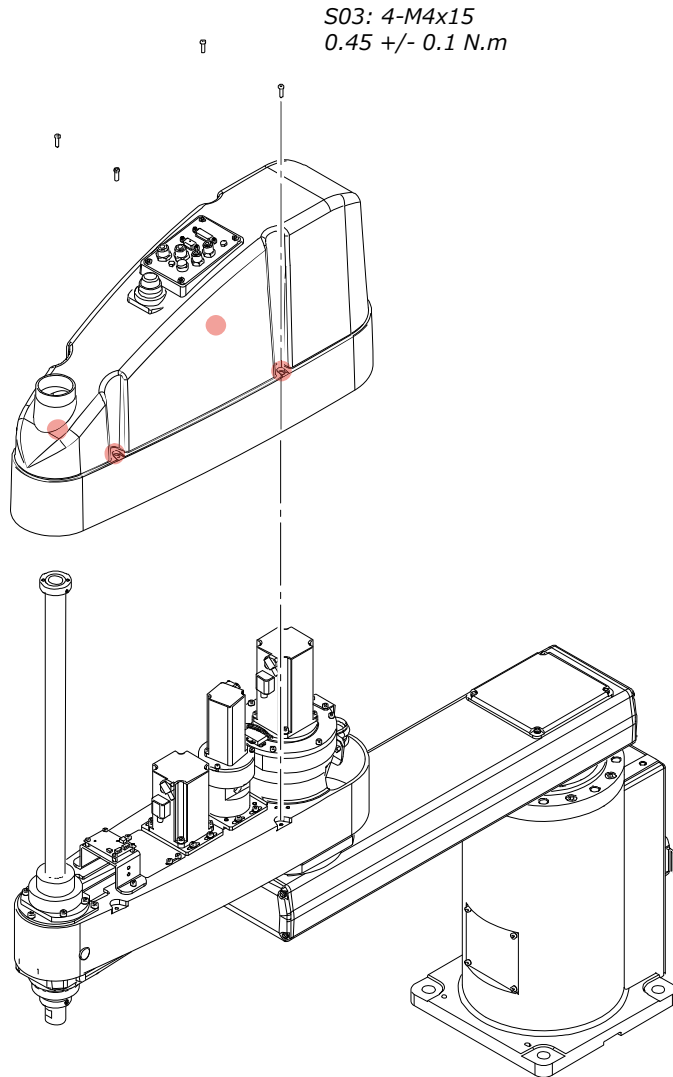

### Preparation

#### Moving the Shaft (Moving to the lower limit)

1. Turn ON the Controller.
2. Press the Brake Release Switch, and lower the shaft to the lower limit taking care to prevent the hand from interfering with peripheral devices.

#### CAUTION

- Be careful of the shaft falling and rotating while the Brake Release Switch is being pressed.
- When the Brake is released by the Brake Release Switch, the J3 and J4 Brakes are released.

3. Turn OFF the Controller.

#### Removing the Bellows

If the Upper Bellows has been attached, remove it. 

#### CAUTION

- The cover cannot be completely removed with user wiring and piping still attached. Place the cover at a location where there is no risk of a load being placed on the cables and the cover falling off.
- The cables for the LED indicator and the Brake Release Switch are located between the Manipulator and the cover. Pulling the cables hard might damage the connectors.
- When installing the cover, be careful not to pinch the cables.
- Secure the Arm Upper Cover, then make sure that the lower limit mechanical stopper does not interfere with the cylindrical part of the Arm Upper Cover.

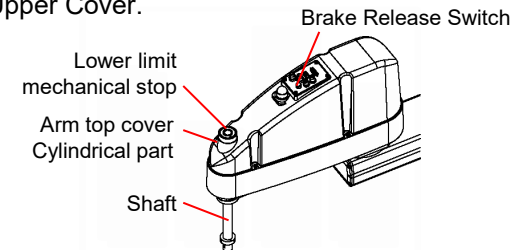

## 2.10.2 Arm Lower Cover

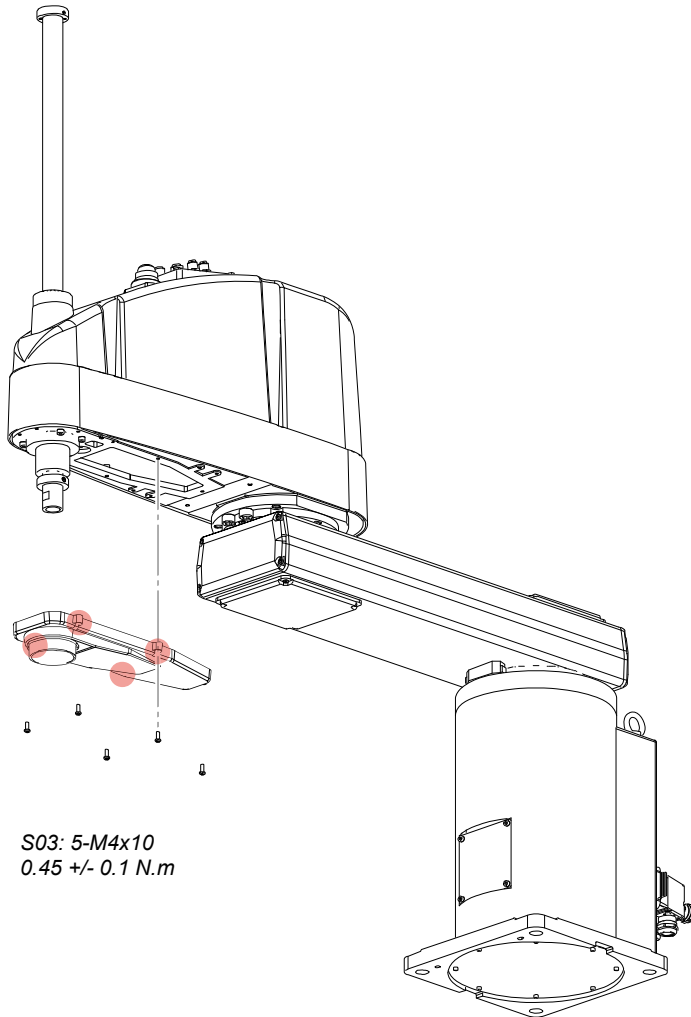

### CAUTION

- The Arm Lower Cover sometimes cannot be removed from the shaft if the hand is installed.
- When replacing or performing other operations on the Ball Screw Spline Unit, remove the hand, and completely remove the Arm Lower Cover.
- If it is ok not to completely remove the Arm Lower Cover, lower the shaft to the lower limit, and lower the Arm Lower Cover before performing maintenance and inspection.
- If the Lower Bellows has been attached, remove it before removing the Arm Lower Cover.

### 2.10.3 Base Bottom Cover

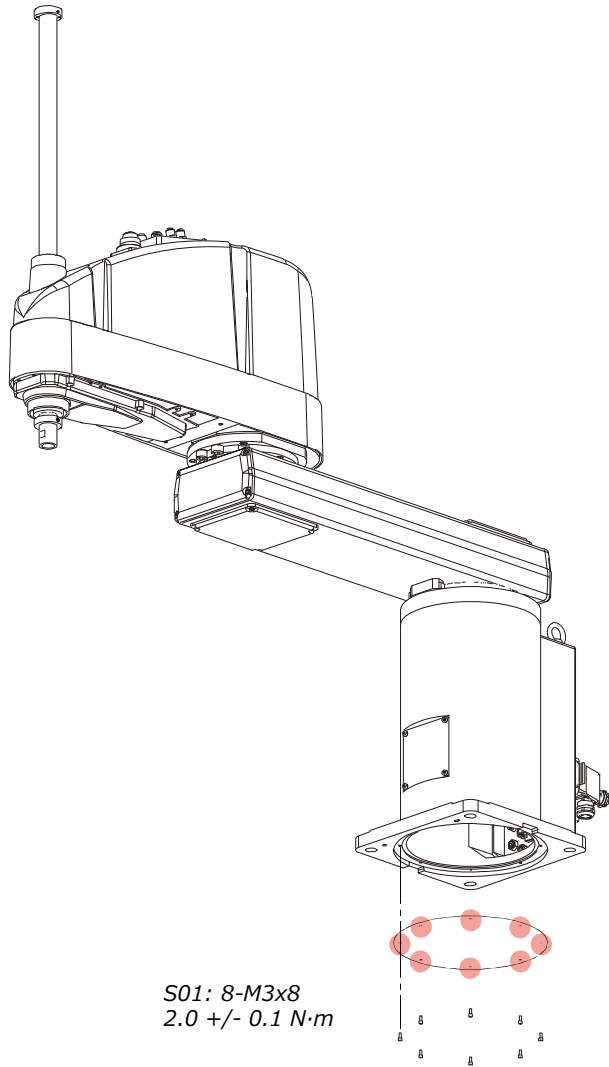

#### Removing the Table Top Mounting Type

Before removing the J1 Motor, turn the Manipulator onto its side. With the table top mounting type, turn the Manipulator over onto its side, and remove the Base Bottom Cover.

#### CAUTION

Use at least two persons to lift and turn the manipulator. Arm #1 and Arm #2 must be supported to prevent falling or accidental movement which may cause damage or injury.

If the bolts used for installing the Manipulator to a table top, etc. are removed without the Manipulator being supported, the Manipulator may fall from the arm side due to the arm's own weight.

### 2.10.4 User Plate

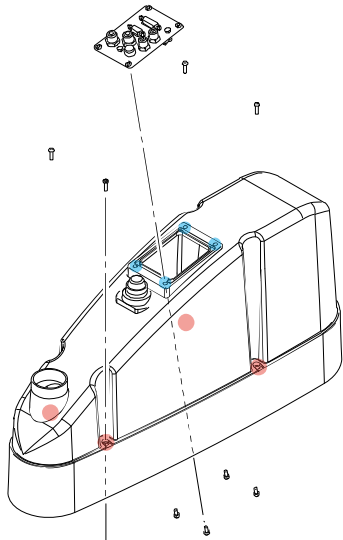

**Step 2**  
**User Plate**  
 S01: 4-M4x8  
 4.0 +/- 0.2 N.m

**Step 1**  
**Arm Upper Cover**  
 S03: 4-M4x15  
 0.45 +/- 0.1 N.m

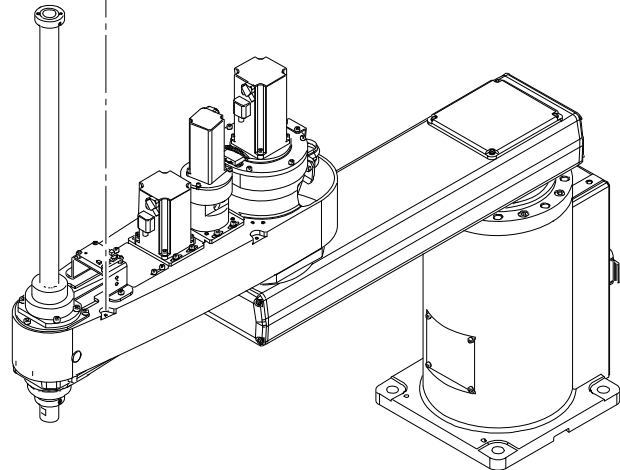

**CAUTION**

- The D-sub cable mounting screws are very small. Take care not to lose them.
- Check the locations of the cables for reconnection of the cables after replacement.

**Disconnecting the Connectors, Cables, and Tubes**  
 Disconnect the connectors, cables and tubes shown in the figure.

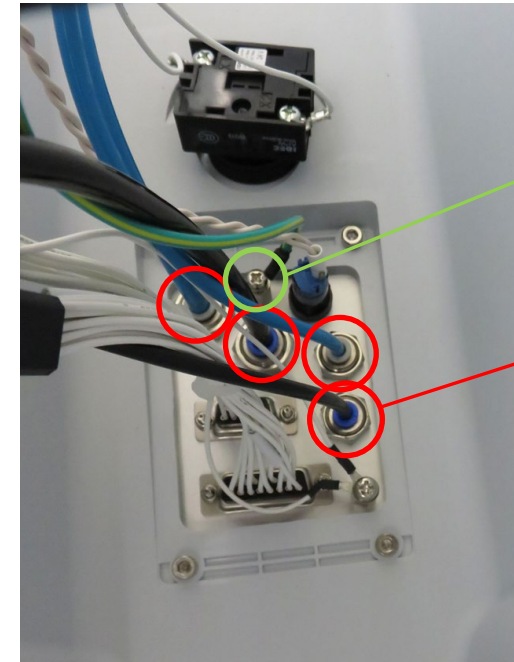

PE10  
 S04: 1-M4x6

Air Tube

**Air Tube**  
 Insert or remove the tube while pressing the release button.



## 2.10.4 User Plate

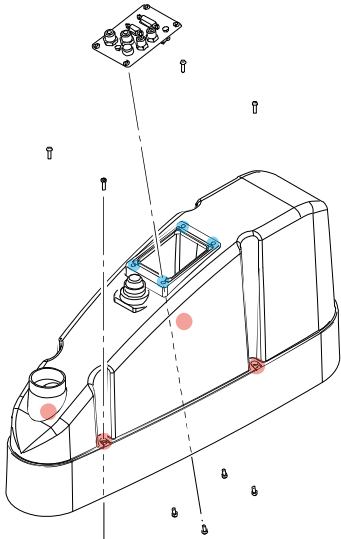

**Step 2**  
**User Plate**  
 S01: 4-M4x8  
 4.0 +/- 0.2 N.m

**Step 1**  
**Arm Upper Cover**  
 S03: 4-M4x15  
 0.45 +/- 0.1 N.m

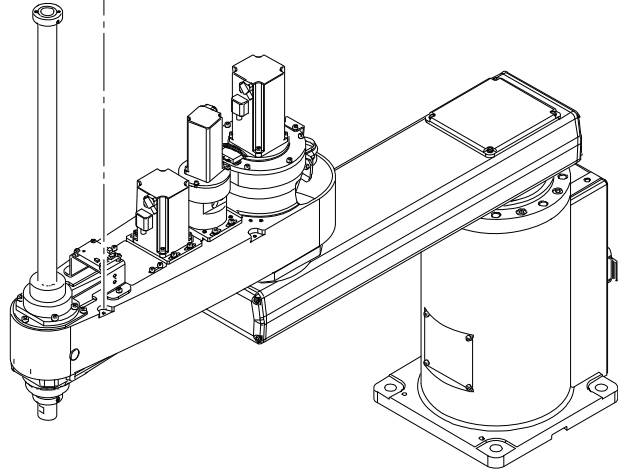

**CAUTION**

- The D-sub cable mounting screws are very small. Take care not to lose them.
- Check the locations of the cables for reconnection of the cables after replacement.

**Disconnecting the Connectors, Cables, and Tubes**  
 Disconnect the connectors, cables and tubes shown in the figure.

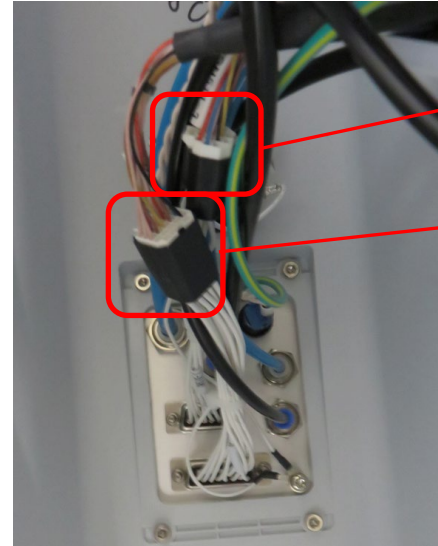

CN511-3 (D-sub 9 pin)

CN521-3 (D-sub 15 pin)



### 2.10.4 User Plate

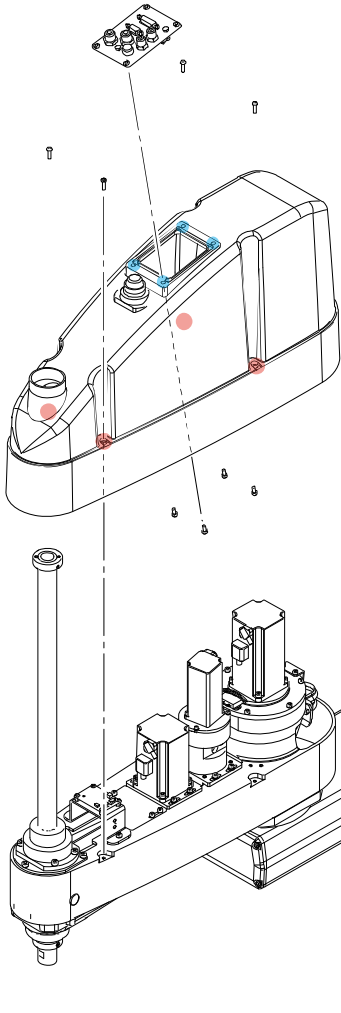

**Step 2**  
**User Plate**  
 S01: 4-M4x8  
 4.0 +/- 0.2 N.m

**Step 1**  
**Arm Upper Cover**  
 S03: 4-M4x15  
 0.45 +/- 0.1 N.m

**CAUTION**

- The D-sub cable mounting screws are very small. Take care not to lose them.
- Check the locations of the cables for reconnection of the cables after replacement.

**Disconnecting the Connectors, Cables, and Tubes**  
 Disconnect the connectors, cables and tubes shown in the figure.

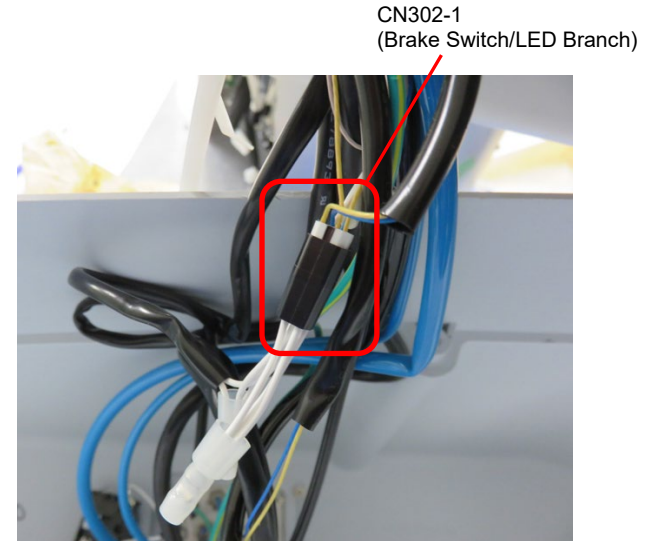
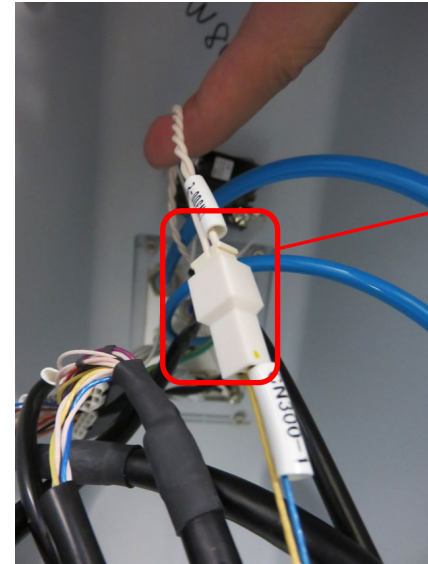

## 2.10.4 User Plate

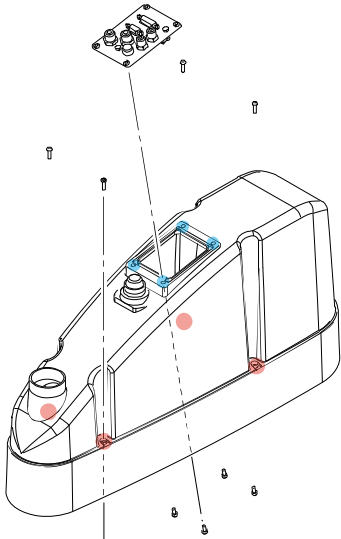

**Step 2**  
**User Plate**  
 S01: 4-M4x8  
 4.0 +/- 0.2 N.m

**Step 1**  
**Arm Upper Cover**  
 S03: 4-M4x15  
 0.45 +/- 0.1 N.m

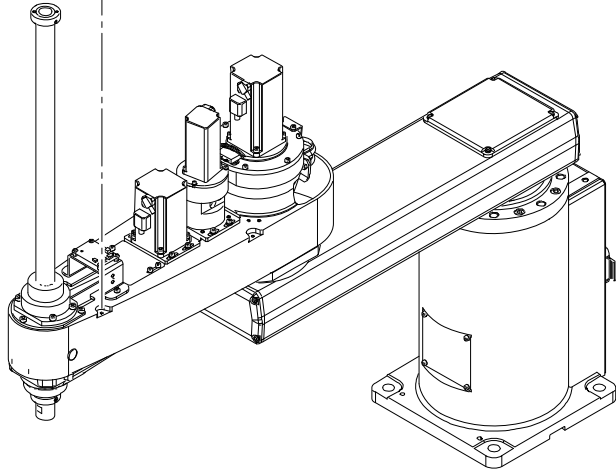

### Removing the User Plate

**POINT**

Remove the bolts shown in the figure, and remove the User Plate from the Arm Upper Cover.

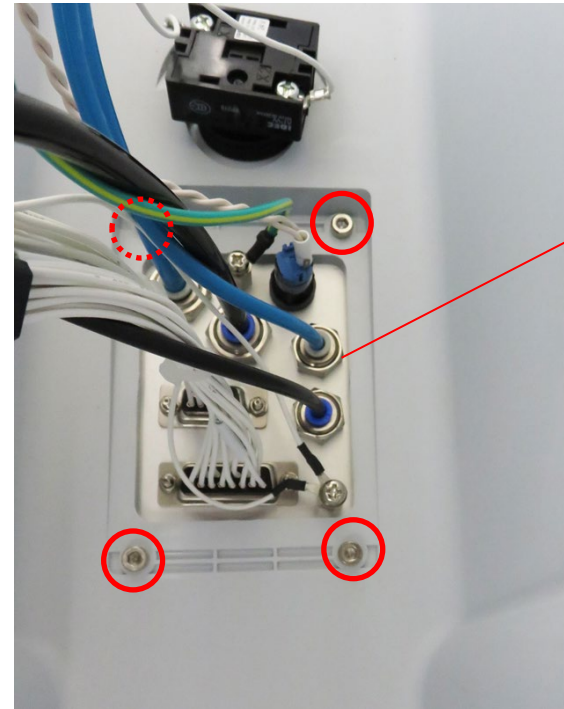

User Plate

### 2.10.5 Connector Plate (Table Top Mounting Type)

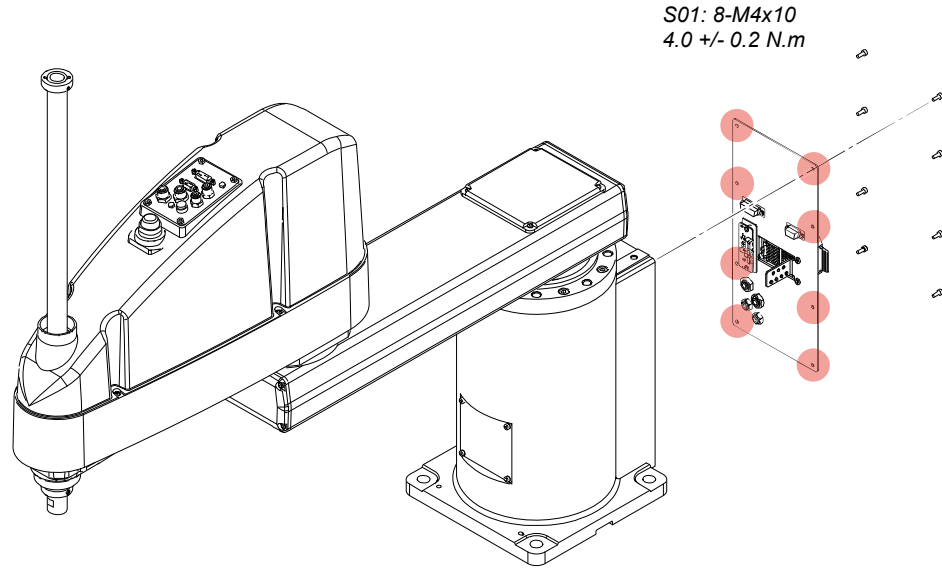

**CAUTION**

- If the M/C cable is connected, remove the connector after turning OFF the Controller.
- Do not pull the Connector Plate with force. It may result in damage to the cables, disconnection, and/or contact failure. These are extremely hazardous and may result in electric shock and/or improper function of the robot system.
- When installing the Connector Plate, do not nip the cables or bend and push them in using excessive force. It may result in damage to the cables, disconnection, and/or contact failure. These are extremely hazardous and may result in electric shock and/or improper function of the robot system.
- When moving cables, check the location of the cables when the Connector Plate is removed and return the wiring to a state that will not result in excessive force being placed on the wiring.

#### Removing the Cables

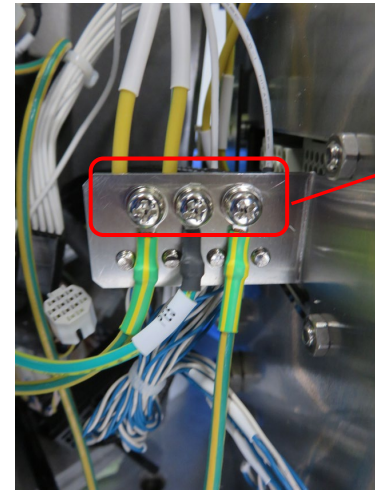
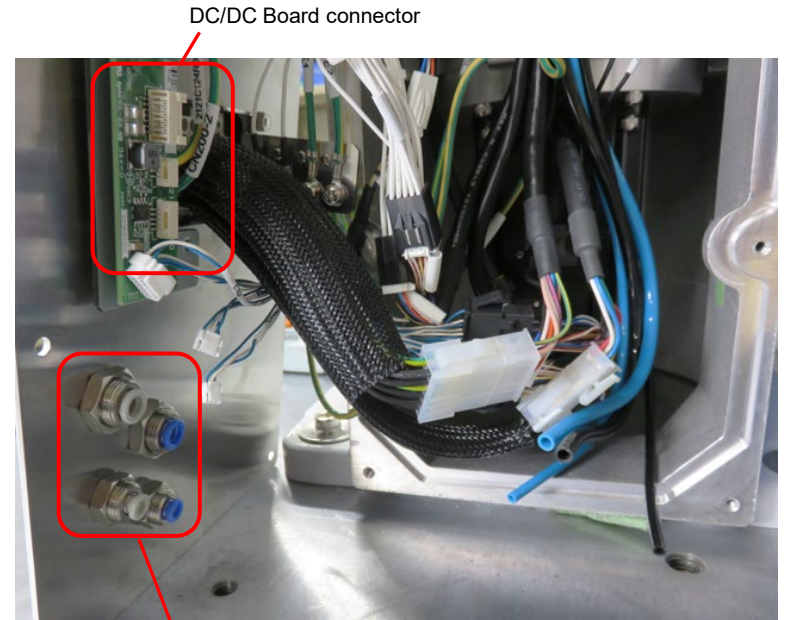

### 2.10.5 Connector Plate (Table Top Mounting Type)

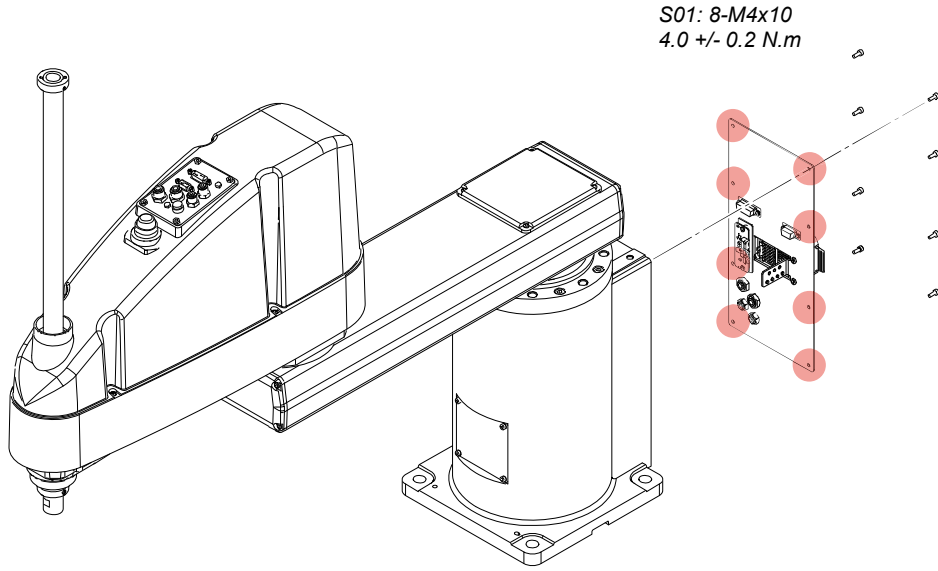

#### Removing the Cables

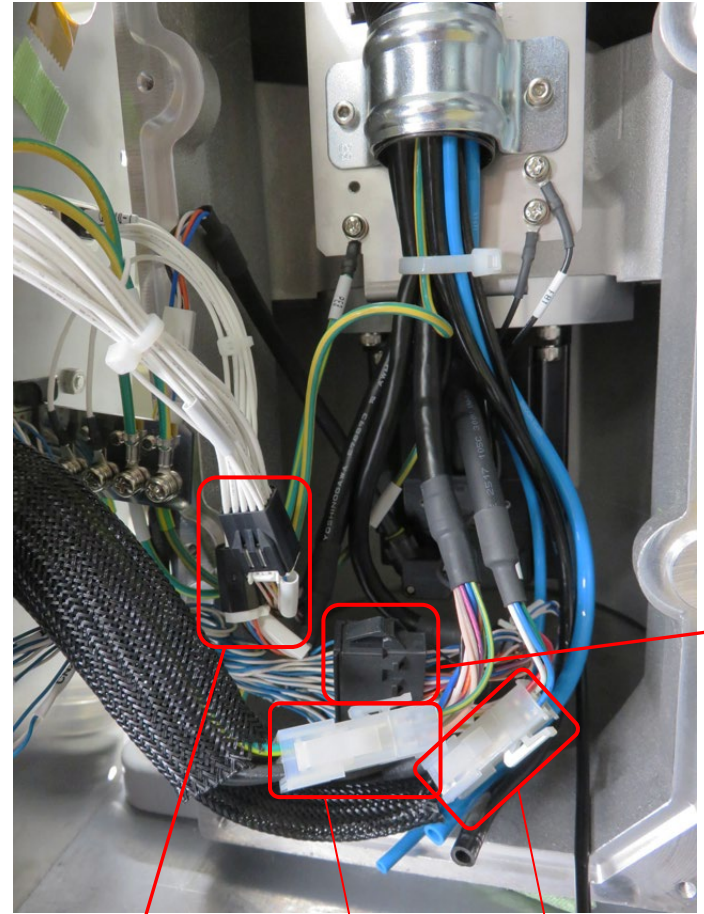

CN511-1, CN521-1  
(D-sub connector)

CN201-1

CN111-1

CN202-1



## 2.10.6 Connector Plate (Wall Mounting Type)

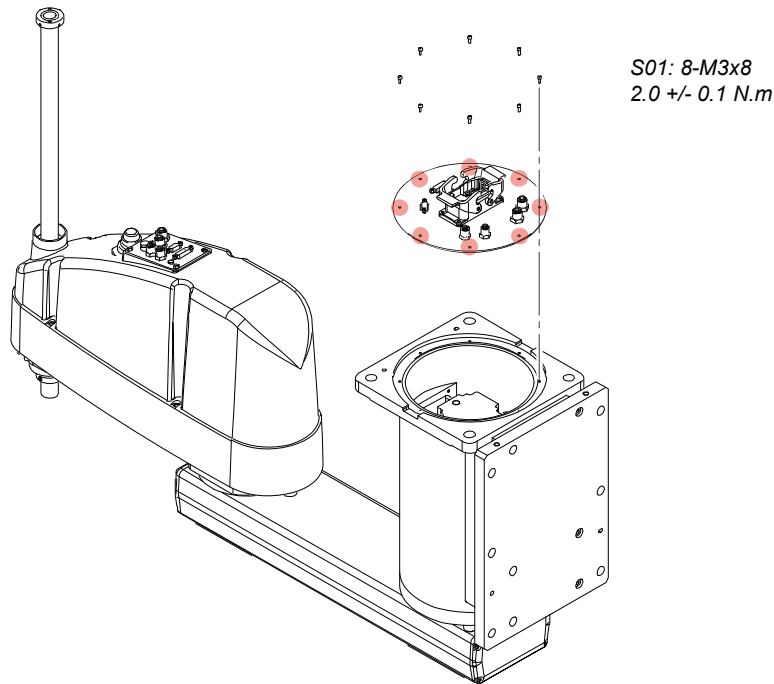

### CAUTION

- If the M/C cable is connected, remove the connector after turning OFF the Controller.
- Do not pull the Connector Plate with force. It may result in damage to the cables, disconnection, and/or contact failure. These are extremely hazardous and may result in electric shock and/or improper function of the robot system.
- When installing the Connector Plate, do not nip the cables or bend and push them in using excessive force. It may result in damage to the cables, disconnection, and/or contact failure. These are extremely hazardous and may result in electric shock and/or improper function of the robot system.
- When moving cables, check the location of the cables when the Connector Plate is removed and return the wiring to a state that will not result in excessive force being placed on the wiring.

Remove the cable, Air Tube and ground wire connected to the plate.

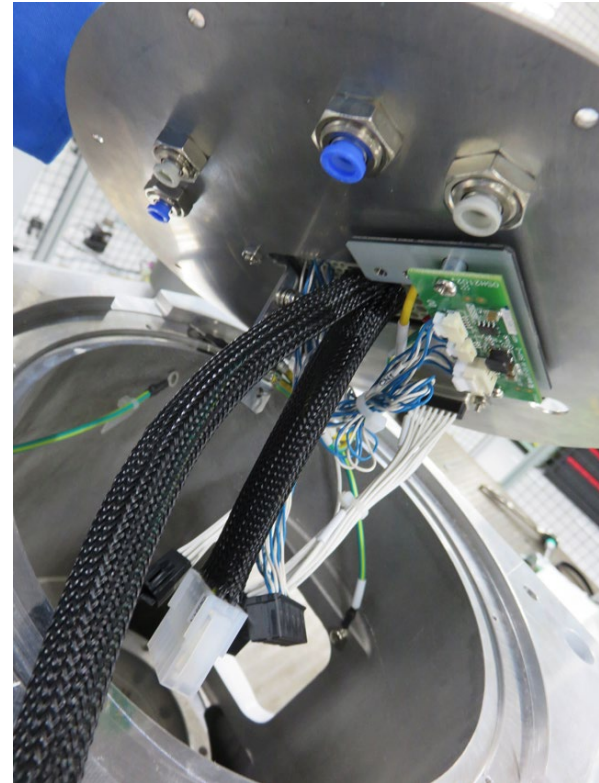

CHAPTER

3

**Adjustment**

## 3.1 Calibration

### 3.1.1 What is Calibration?

#### Calibration

When parts (Motors, Reduction Gears, Brakes, Timing Belts, Ball Screw Spline Units, etc.) are replaced, the origin stored in the Motor and the origin stored in the Controller become misaligned, and the Manipulator cannot be controlled correctly.

Therefore, after the parts are replaced, resetting the encoder and then calibration are required to bring these origins into alignment.

Calibration is performed using the Calibration Marks that indicates the 0-pulse position.

- NOTE** Calibration is different from teaching\*.
- \* Teaching is the operation of teaching set coordinate points (including the posture) within the Manipulator's operating area.

#### When Calibration is Required

After replacing the Motor, Reduction Gear, Brake, Timing Belt, Ball Screw Spline Unit, etc.

- NOTE**
- When coordinates for the Manipulator working point require calculation, it is important for Joint #2 to be calibrated accurately. Execute the procedure in "Calibration Using Right / Left Arm Orientations" to accurately calibrate Joint #2. For details, refer to [3.1.6.2 Accurate Calibration of Joint #2](#).
  - When calibrating Joint #4, due to the structure of the Manipulator Joint #3 and #4 must be calibrated at the same time.



### 3.1.2 Calibration Methods

#### Using the calibration wizard

EPSON RC+ has a wizard for calibration.

The wizard guides you through the calibration process from specifying the joints to be adjusted and the adjustment items (calibration to be performed).

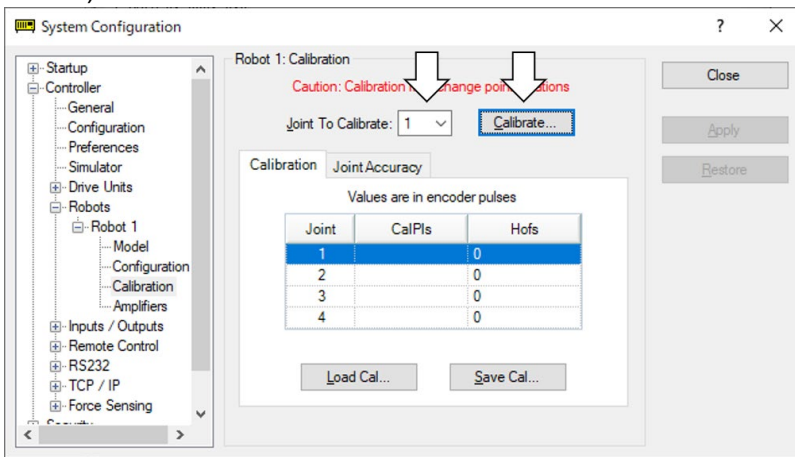

To calibrate without using the calibration wizard, refer to [3.1.6.4 Calibration Procedure without Using Calibration Wizard](#).

### 3.1.3 Workflow

#### When using the calibration wizard

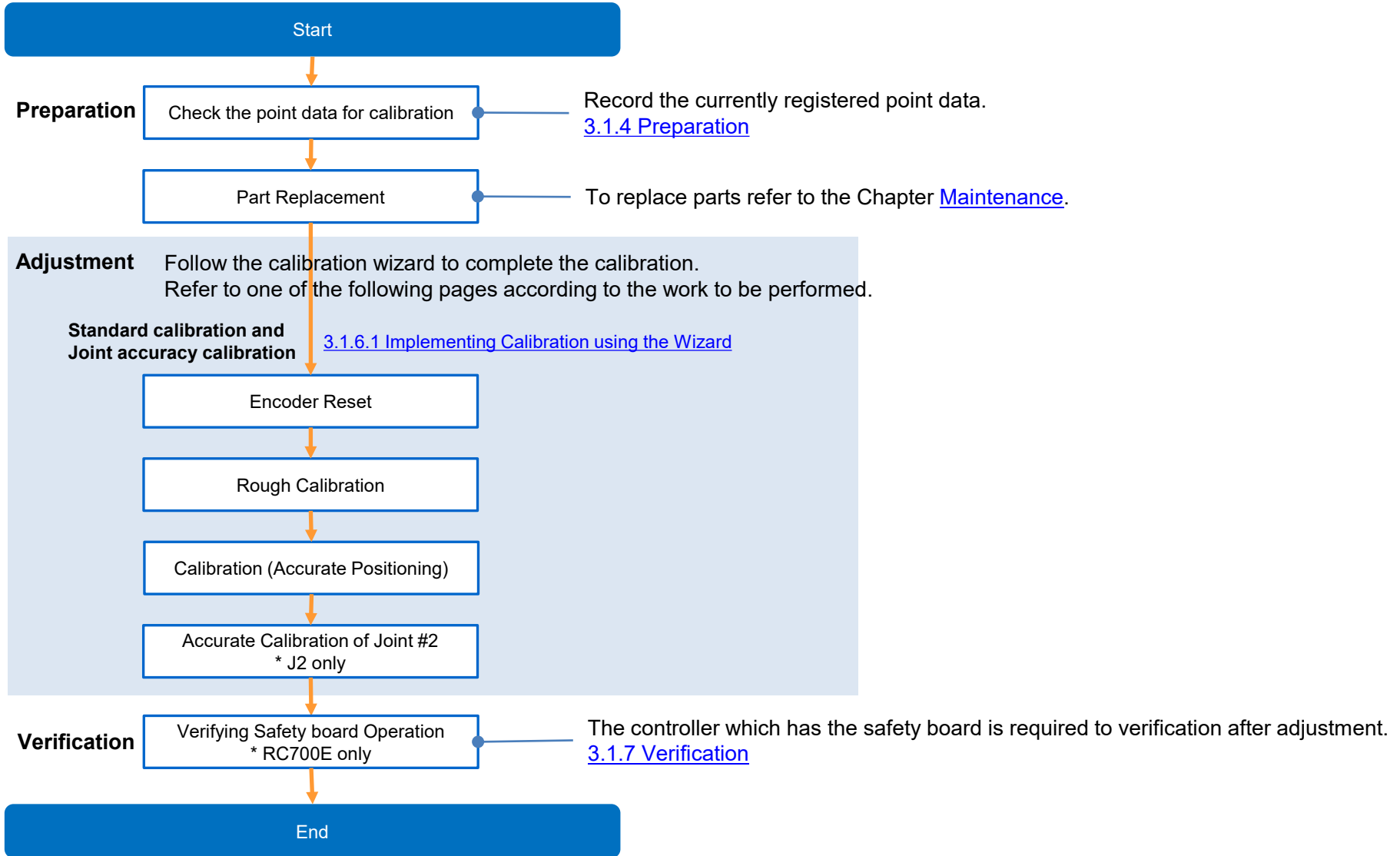

### When performing calibration manually (without using the calibration wizard)

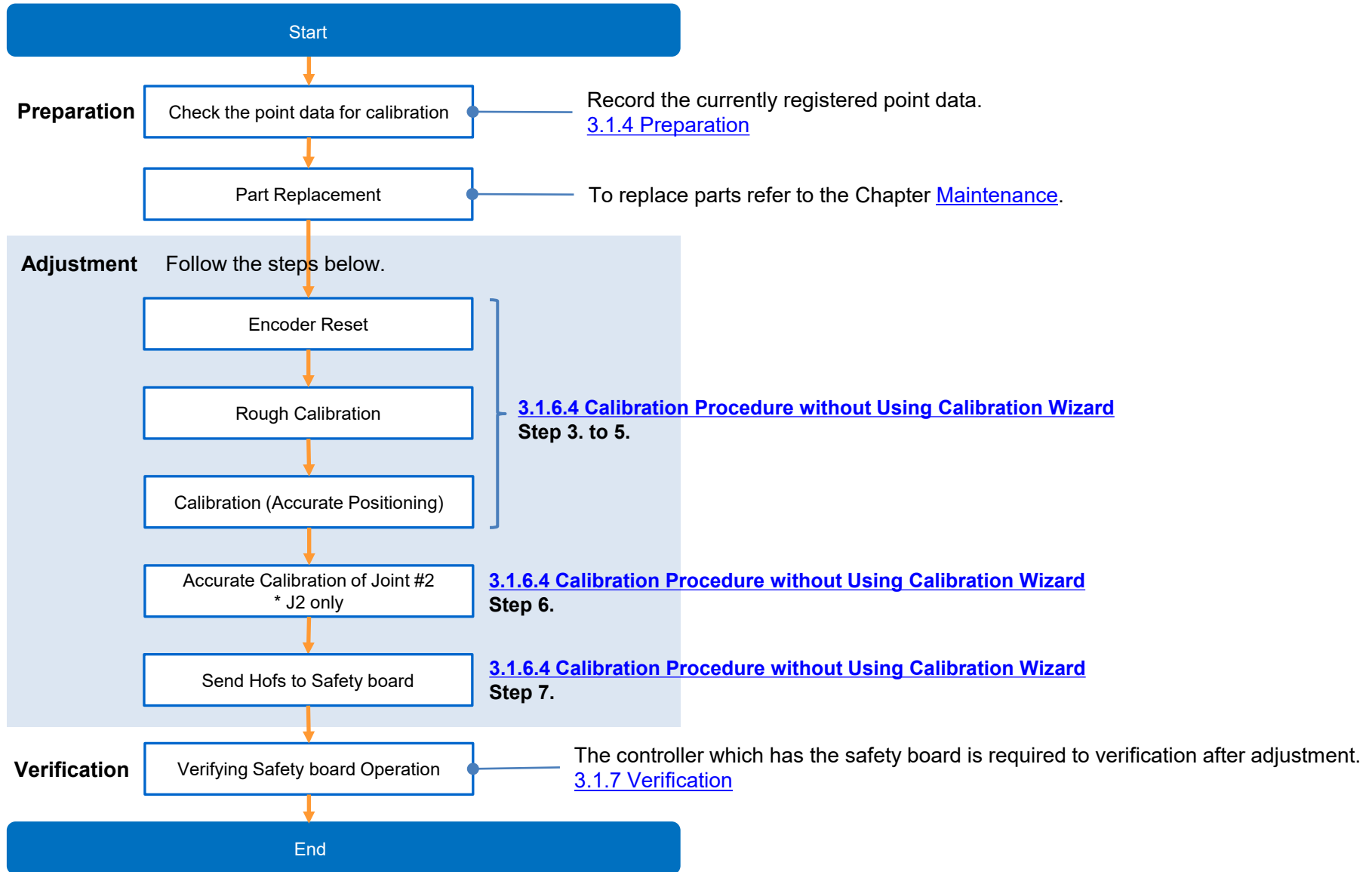

### **3.1.4 Preparation**

To reproduce the exact manipulator position, check the point data for calibration before starting the calibration.

Before replacing parts, select point data in the currently registered point (pose) data where accuracy can be easily checked, and display the pulse value using the following procedure to record it.

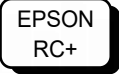
 Execute the following command from the [Command Window].

>PULSE

PULSE: [Joint #1 Pulse value] pls [Joint #2 Pulse value] pls [Joint #3 Pulse value] pls [Joint #4 Pulse value] pls

### 3.1.5 0-Pulse Position of Each Joint

To perform calibration using the 0 pulse position, refer to the figure below.

#### Joint #1/Joint #2

##### Guideline for the 0-pulse position

Joint #1 : position aligned with X-axis in Robot coordinate system

Joint #2 : position where Arms #1 and #2 are in a straight line

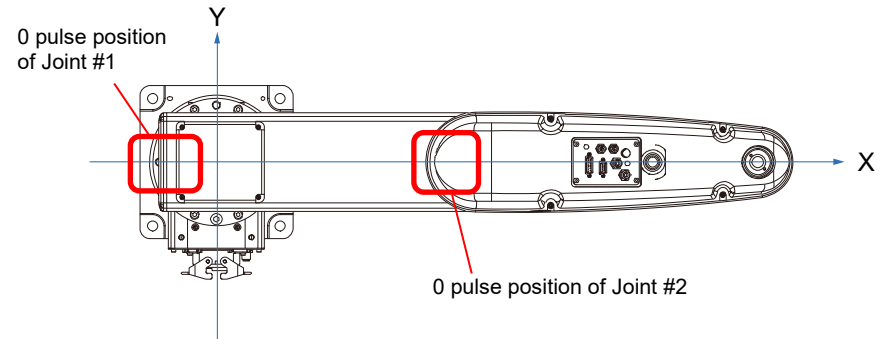
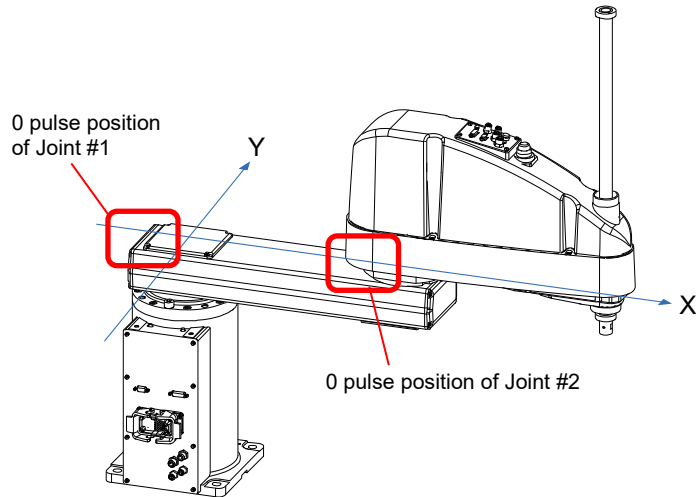

**Joint #3/Joint #4**

**Guideline for the 0-pulse position of Joint #3**

Upper limit position within the range of motion

The height of Joint #3 depends on Manipulator model.

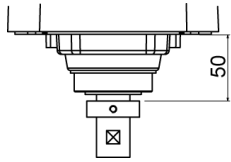

Standard model

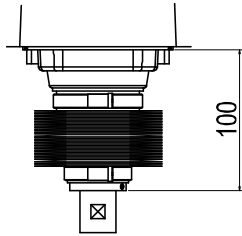

Cleanroom model  
Protected model

**Guideline for the 0-pulse position of Joint #4**

Position where the flat surface on the shaft faces toward the tip of Arm #2.

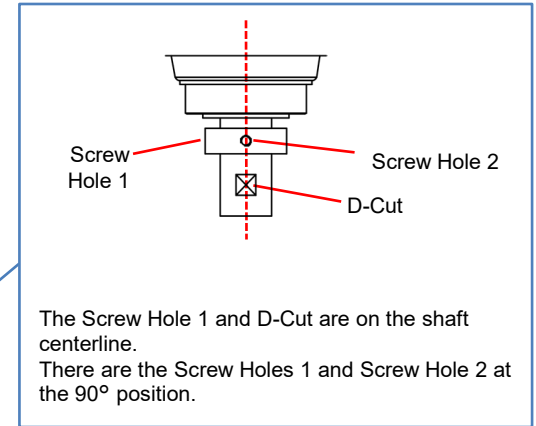
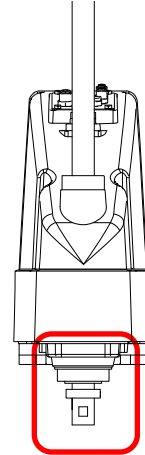

### 3.1.6 Implementing Calibration



WARNING

- To ensure safety, a safeguard must be installed for the robot system. For details on the safeguard, refer to EPSON RC+ User's Guide: Installation and Design Precautions in the Safety chapter.
- Before operating the robot system, make sure that no one is inside the safeguarded area. The robot system can be operated in the mode for teaching even when someone is inside the safeguarded area. The motion of the Manipulator is always in restricted (low speeds and low power) status to secure the safety of an operator. However, operating the robot system while someone is inside the safeguarded area is extremely hazardous and may result in serious safety problems in case that the Manipulator moves unexpectedly.

**NOTE** If Err9719 or 5019 (Position failure of the absolute encoder.) occurs after replacing the motor or in other situations, apply the procedure of [3.1.6.4 Calibration Procedure without Using Calibration Wizard](#)- 3. Encoder Initialization and then, start the calibration wizard.

The reference point (a point to check the accuracy) needs to be specified for calibration.

#### Command Input

Calibration procedures include the process to input commands. Select EPSON RC+ menu - [Tools] - [Command Window] to use the command window.

The information above is omitted in the calibration procedure.

#### Jog Motion

The process to set the jog motion is included in the [Jog & Teach] page of the Robot Manager. Select EPSON RC+ menu - [Tools] - [Robot Manager] and select the [Jog & Teach] tab to use the [Jog & Teach] page.

The information above is indicated as [Jog & Teach] in the calibration procedure, and omitted in the calibration page.



### 3.1.6.1 Implementing Calibration using the Wizard

The same calibration procedure is used for each joint.

The follow the steps below are calibration using Joint #1. Follow the steps below to calibrate other joints.

(1) Start the calibration wizard.

I. Select EPSON RC+ menu - [Setup] - [System Configuration].

II. Select [Robots] - [Robot\*\*] - [Calibration].

**NOTE** Only selected robot can be calibrated.

III. Select the joint and click the <Calibrate...> button.

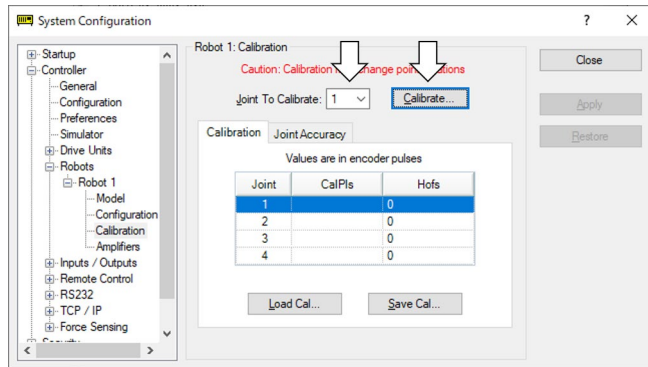

(2) Confirm the warning message and click the <Yes> button.

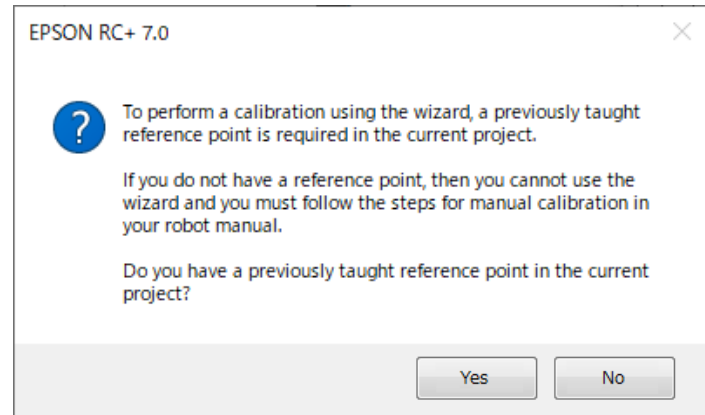
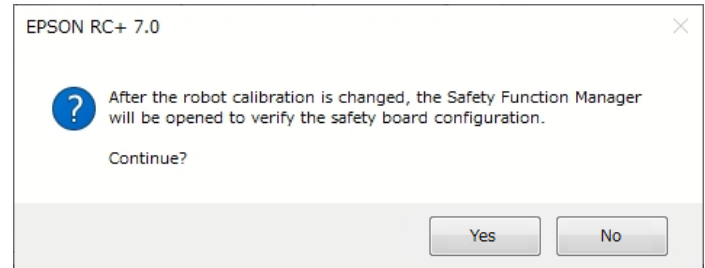

- (3) Move the joint to calibrate manually to approximate 0 pulse position, as shown in the dialog. After moving the joint click the <Next> button.

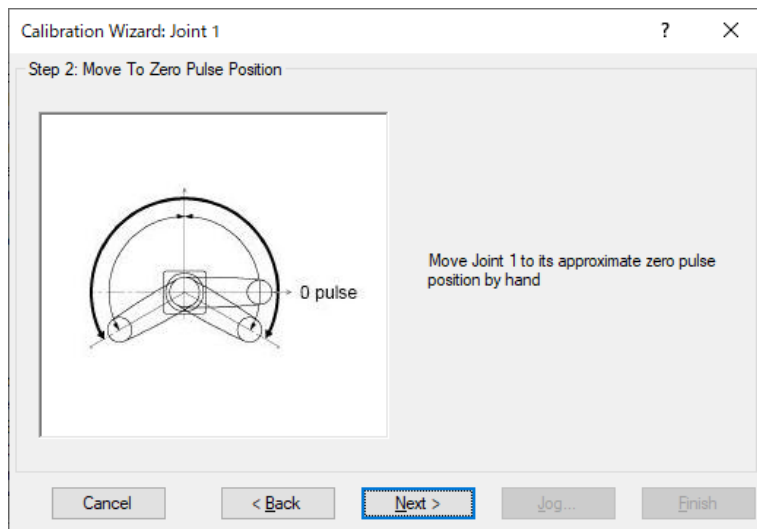

0 pulse position of Joint #1: position aligned with X-axis in Robot coordinate system

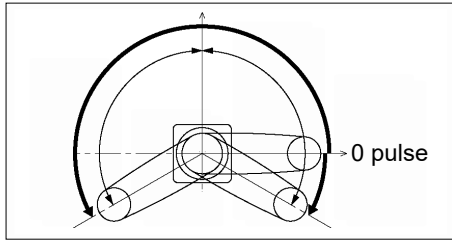

0 pulse position of Joint #4: position where the D-Cut on the shaft faces toward the tip of Arm2

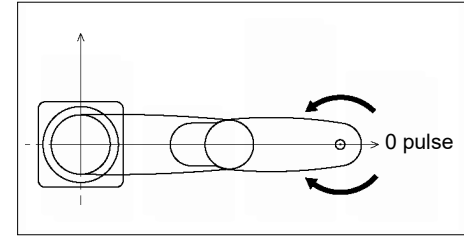

0 pulse position of Joint #2: position where Arm1 and Arm2 are in a straight line (Regardless of the Joint #1 direction.)

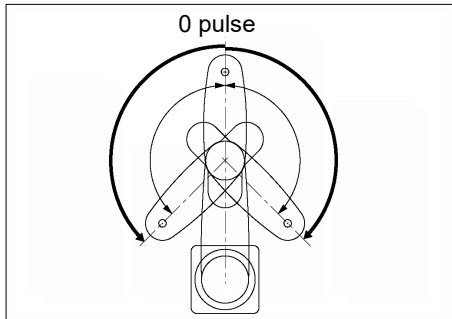

0 pulse position of Joint #3: upper limit position in motion range

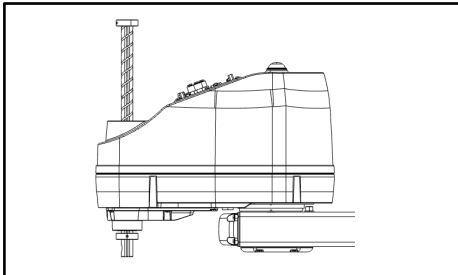

**NOTE** For details on the 0-pulse position, refer to [3.1.5 0-Pulse Position of Each Joint.](#)

(4) Reset the encoder. Click the <Yes> button.

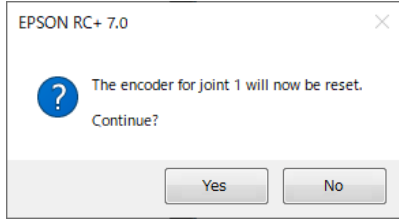

(5) The Controller restarts.  
 \* This window will disappear when the Controller starts up.

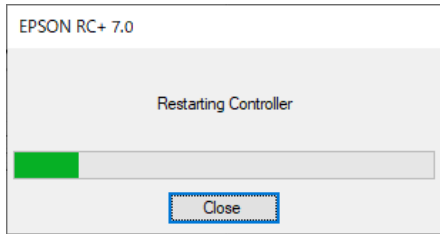

**NOTE**

- Warning 590 (Detect the different of the calibration settings in the controller and Safety Board) occurs when calibration settings in the controller are updated.
- Warning 590 is cleared by updating the Hofs value in the safety board after completing calibration. [Step \(19\)](#)

(6) Select the reference point to use for calibration, and click the <Next> button.

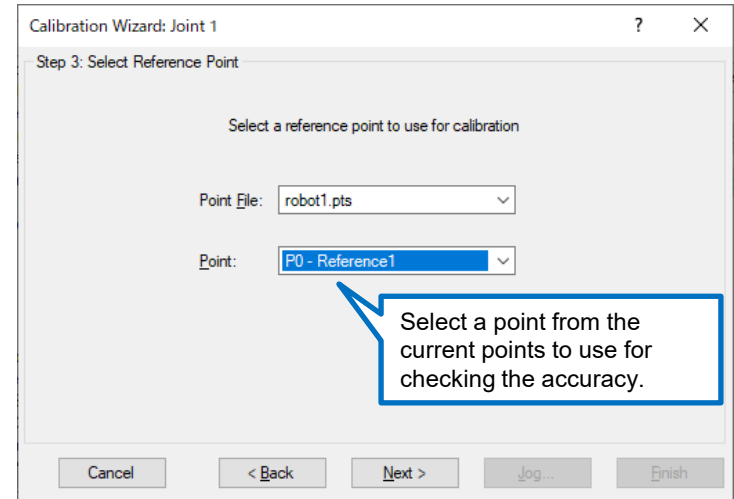

(7) Jog the end effector to approximate reference point for rough calibration. Click the <Jog> button.

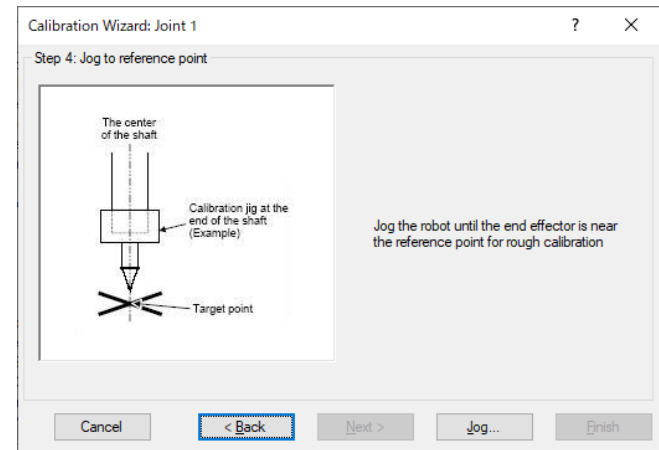

- (8) Open the [Control Panel] tab and execute <Reset> to clear an error related to the safety board.

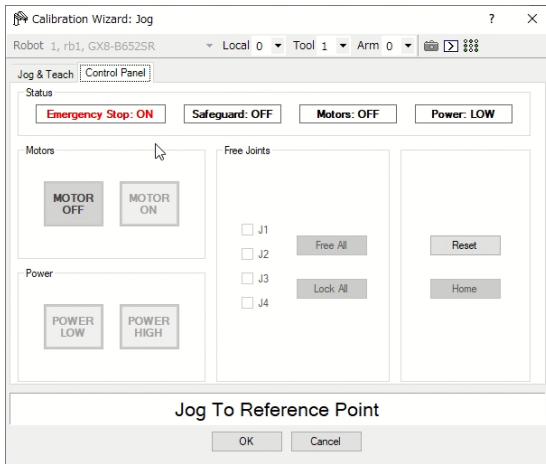

- (9) Jog the end effector to approximate reference point in the [Jog & Teach] dialog and then click the <OK> button.  
 \* Before operating the robot, open the [Control Panel] tab and execute <Motor ON>.

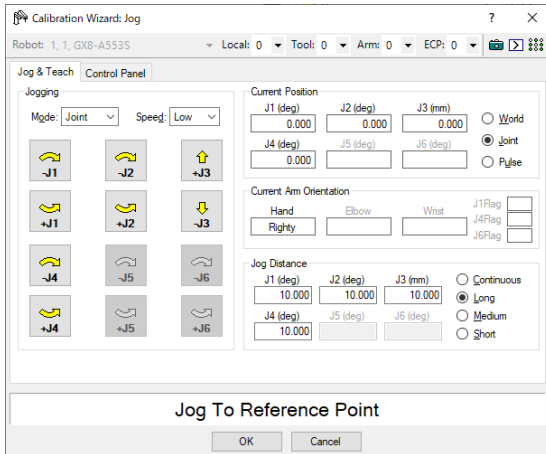

- (10) Click the <Next> button.

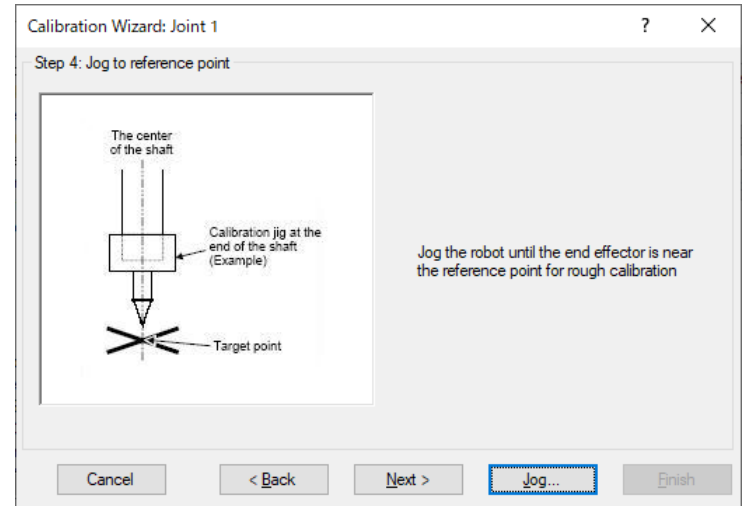

- (11) The Manipulator moves to the reference point. Click the <Execute> button.

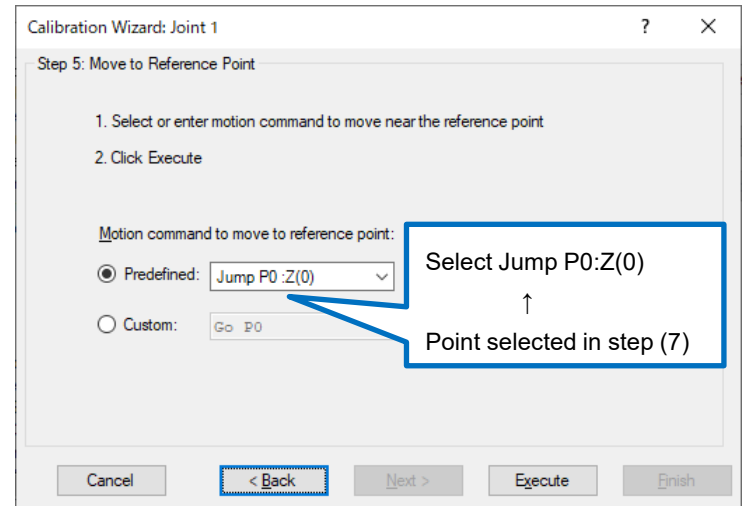

- (12) Confirm the message and click the <Yes> button.

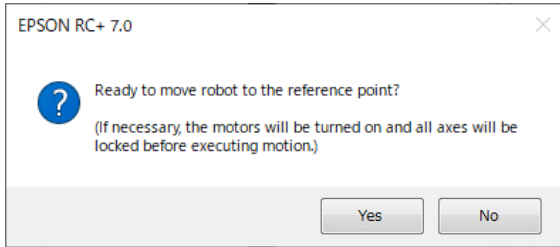

- (13) After the Manipulator moves to the reference point, click the <Next> button.

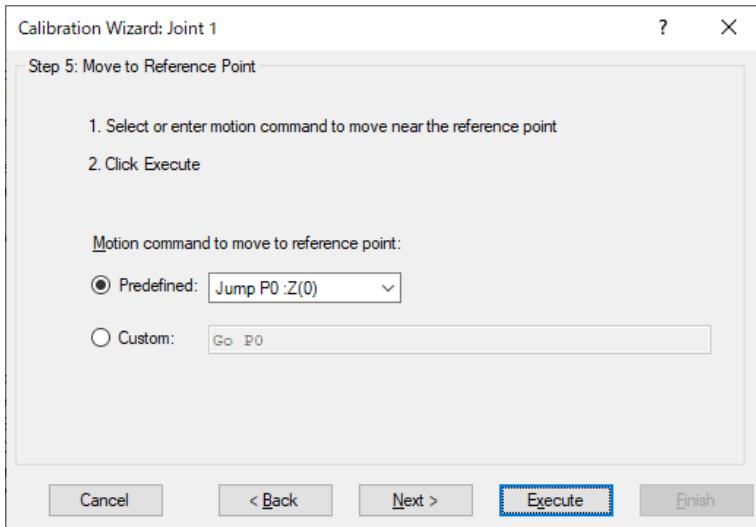

- (14) Jog to the accurate reference position. Click the <Jog> button.

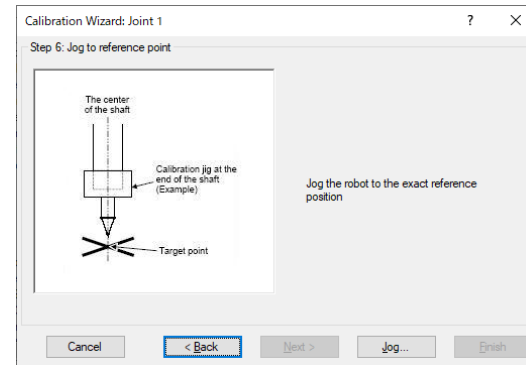

- (15) Jog to the accurate reference position and adjust the position. Click the <OK> button.

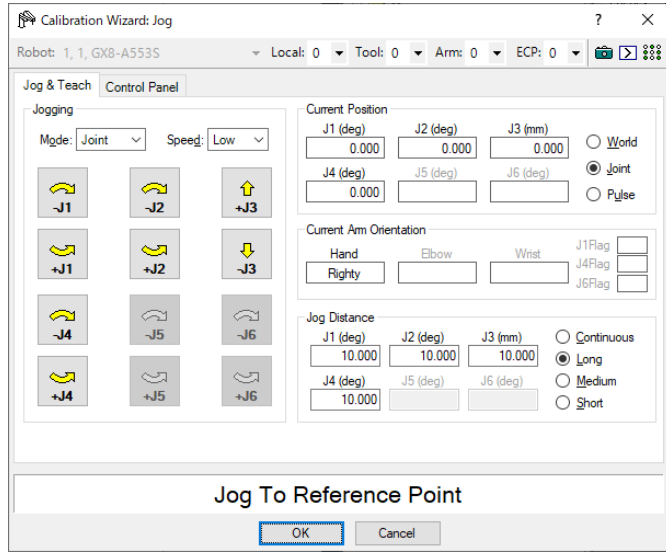

Adjust to the accurate position and move Joint #3 to around 0 pulse.

- (16) Click the <Next> button.

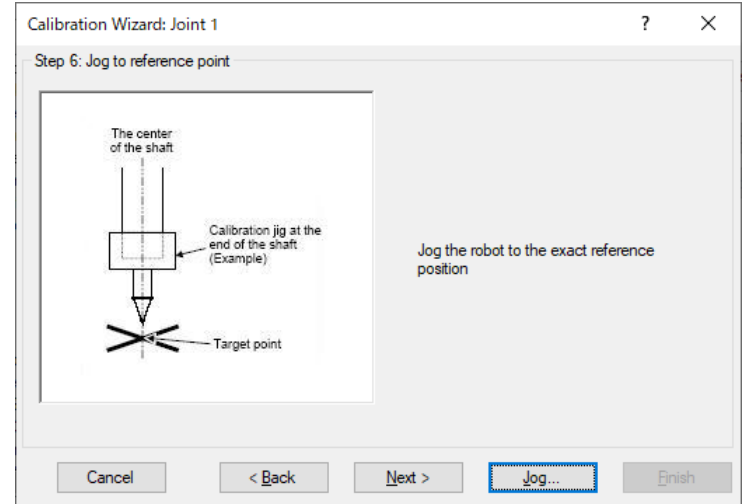



- (17) Execute the procedure in “Calibration Using Right / Left Arm Orientations” to accurately calibrate Joint #2 only.  
\* Go on to the step (18) for the other joints calibration.

- i. Move to another point that has different pose (from righty to lefty) using Jump command. Click the <Yes> button.

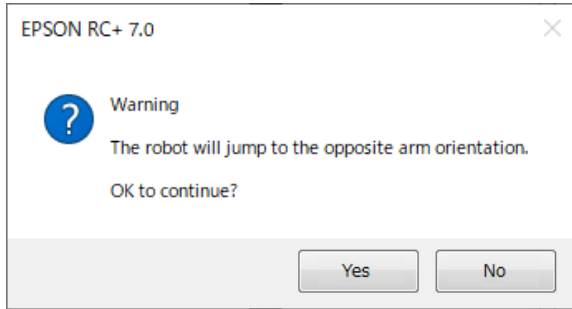

- ii. Jog to the accurate reference position. Click the <Jog> button.

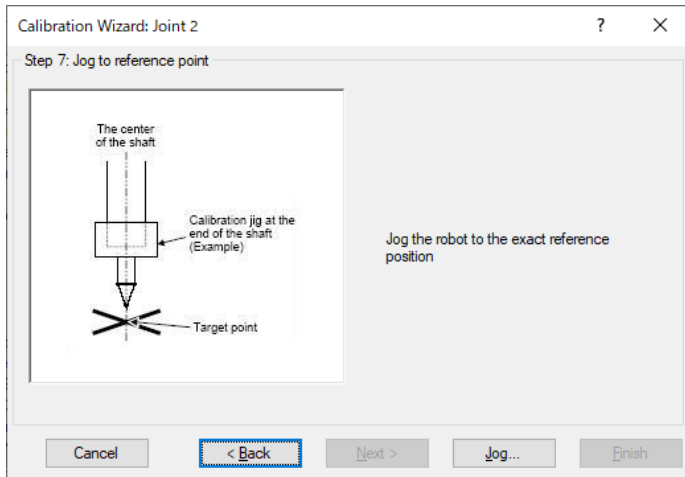

- iii. Jog to the accurate reference position and adjust the position. Click the <OK> button.

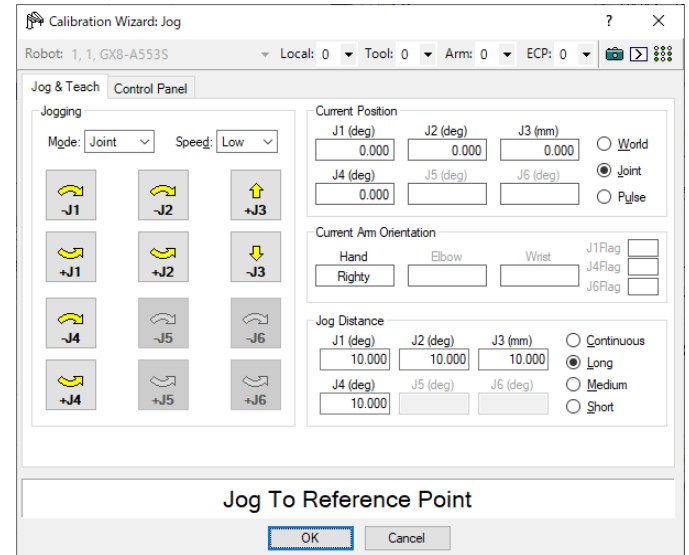

- iv. Click the <Next> button.

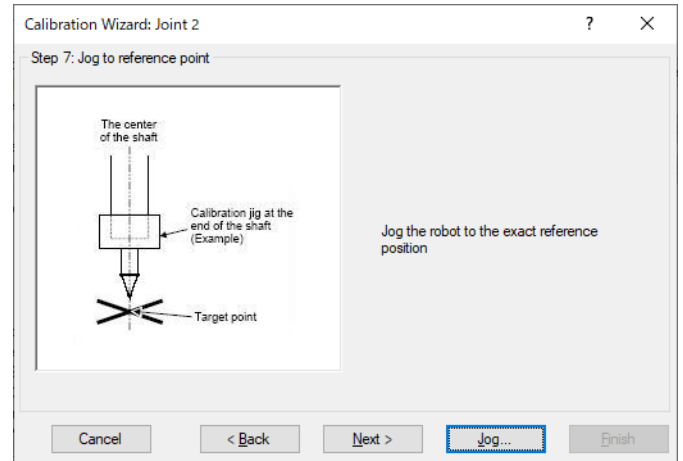

(18) Calibration is complete. Click the <Finish> button.

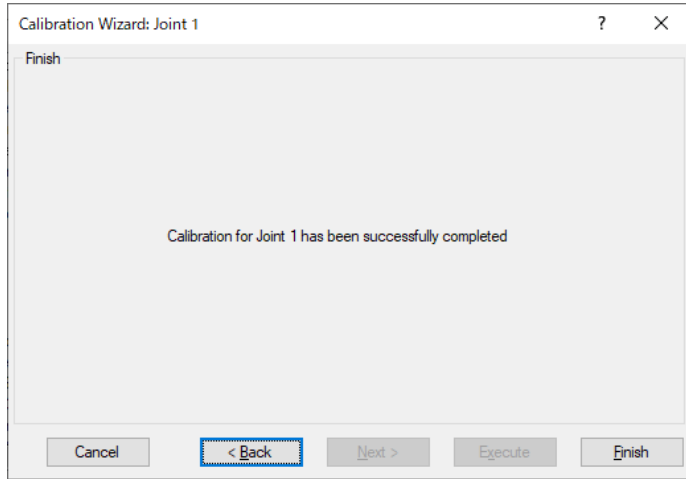

(19) On RC700E, send the Hofs value to the safety board.  
 \* On RC700D, go on to the step (20).

i. Confirm the warning message and click the <OK> button.

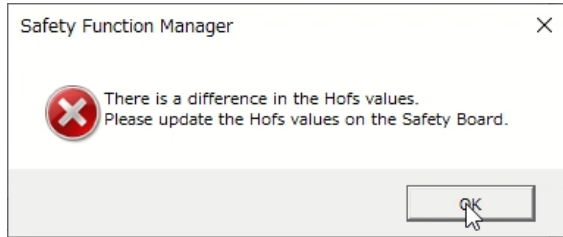

ii. Click <Send Hofs to the Safety Board> button.

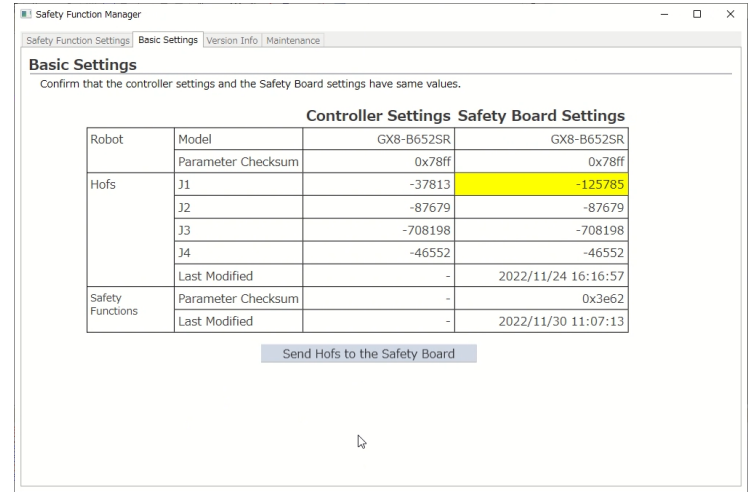

iii. Confirm the warning message and click the <OK> button.

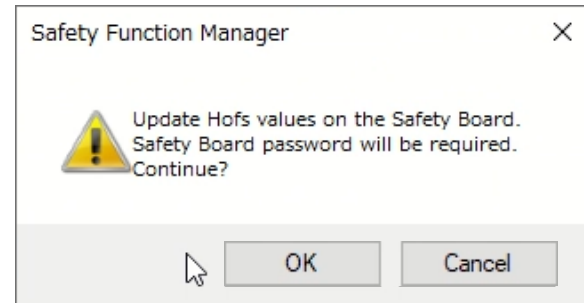

iv. Enter the password and click <Confirm> button.

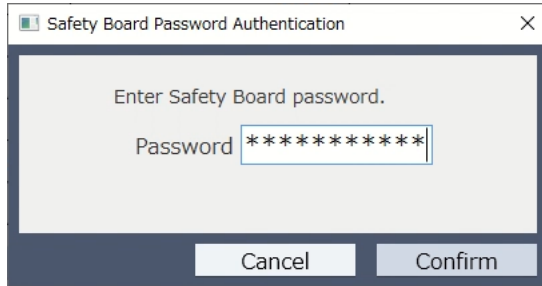

v. Confirm the warning message and click the <OK> button.

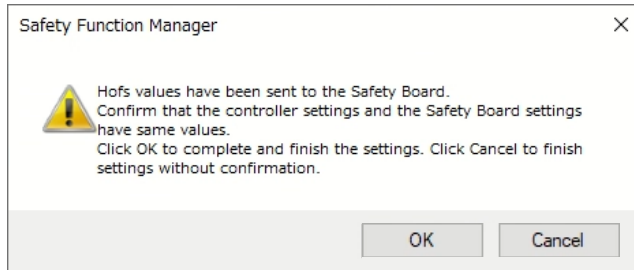

vi. Confirm the message and click the <OK> button.

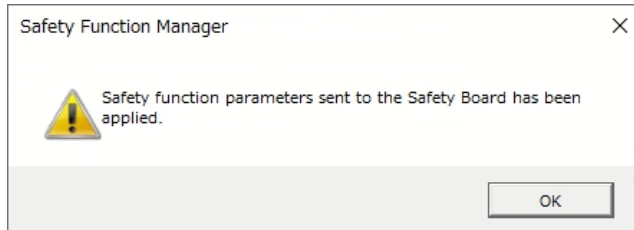

vii. Confirm the message and click the <OK> button.

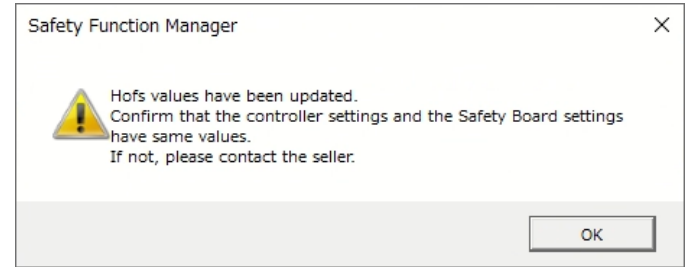

viii. The Controller restarts.

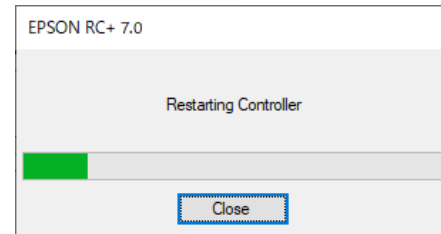

(20) Move the Manipulator to other points and check if it can move without problems.  
Teach points where appropriate.

### 3.1.6.2 Accurate Calibration of Joint #2

When coordinates for the Manipulator working point require calculation, it is important for Joint #2 to be calibrated accurately.

**NOTE** If the calibration of Joint #2 is performed in [3.1.6.4 Calibration Procedure without Using Calibration Wizard](#), configure “Calibration Using Right / Left Arm Orientations” by the wizard.

The reference point is the center of the Ball Screw Spline shaft during this calibration. When there is a misalignment between the center of the end effector and the center of the Ball Screw Spline shaft, remove the end effector and perform the calibration of the shaft.

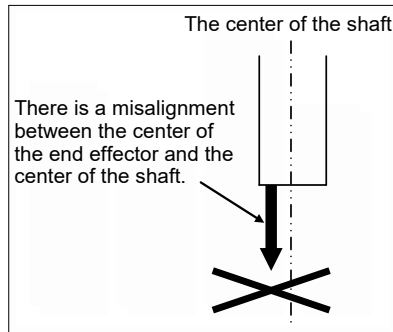

Make a calibration jig as shown in the right figure and attach it on the end of the shaft to make the center of the shaft clear. Decide a target point and mark a cross (X) on it so that you can easily verify the center of the shaft after switching the arm pose between right and left.

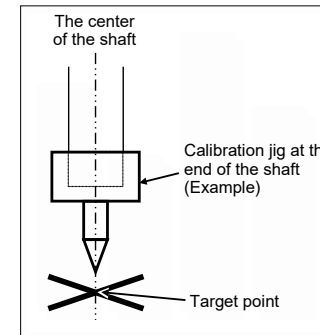

After removing the end effector and performing the calibration, install the end effector and move the Manipulator to the teaching point to verify whether there is a positional gap. If there is a positional gap, fine-tune the installation position of the end effector and teach the point again.

Coordinates for the working point requires calculation in the following cases:

- Teaching the working point by entering the coordinate values (MDI teaching)
- Switching the arm orientation between right and left at a given point
- Using the Pallet command
- Executing CP control (such as linear or circular interpolation)
- Using the Local command
- Pose data specified with relative coordinates <Example: P1+X(100) >
- Vision Guide camera calibrations

### 3.1.6.3 Calibration Using Right / Left Arm Orientations

- (1) Check the point data for calibration  
Use a pose (point) you can easily verify the accuracy within the work envelop of both right and left arm. Then, check the number of pose (point) you want to use.
- (2) Open the [Tools] menu - [Robot Manager] - [Control Panel] and click the MOTOR ON.
- (3) Click [Control Panel] - <Free All> button to free all joints.  
Now, you can move arms by hands.
- (4) Move the arms to the position of point data for calibration in rightly arm orientation.
- (5) From the current position, teach any point data number unused.  
This point is now called P1.  
Specify the point number "1" and click the <Teach> button in [Jog & Teach].
- (6) Click the <Lock All> button in the [Control Panel] to lock all joints.
- (7) Switch to the lefty arm orientation. Then, move the arm to the same point.  
>Jump P1/L:Z(0) 'Change the arm orientation from rightly to lefty, Z is the maximum position  
\* If there is interference on the way from right to lefty, click the <Free All> button in the [Control Panel] and change the arm orientation to lefty by hands. Then, go to the step (6), (7).
- (8) The joints are slightly out of position.  
Adjust the gap with the -Z in the Jogging group in the [Jog & Teach]. Then, teach another point data number unused.  
This point is now called P2.  
Specify the point number "2" and click the <Teach> button in [Jog & Teach].
- (9) Input the new Hofs value.  
>Hofs Hofs (1), Hofs (2) + (Ppls(P1,2) + Ppls(P2,2)) / 2,  
Hofs(3), Hofs(4)

- |   |
|---|
| <p><b>NOTE</b></p> <ul style="list-style-type: none"> <li>• Warning 590 (Detect the different of the calibration settings in the controller and Safety Board) occurs when the Hofs command are executed.</li> <li>• Warning 590 is cleared by updating the Hofs value in the safety board.</li> </ul> |
|---|

- (10) From the current lefty arm orientation (the position in the step (8)), teach the point data number used in the step (8). This point is now called P2.  
Specify the point number "2" and click the <Teach> button in [Jog & Teach].
- (11) Switch to the righty arm orientation. Then, make sure the Manipulator moves to the correct position.  
>Jump P2/R ' Change the arm orientation from lefty to righty  
\* If there is any interference on the way from lefty to righty, click the <Free All>button in the [Control Panel] and change the arm orientation to righty by hands. Then, go to the step (6), (11).
- (12) Move the Manipulator to other point data and make sure it moves to the correct position.  
Teach some more points if required.  
\* Delete the two points taught for the Joint #2 calibration.



### 3.1.6.4 Calibration Procedure without Using Calibration Wizard

**NOTE** This section indicates the calibration without using the calibration wizard of EPSON RC+. For details of calibration using the calibration wizard, refer to [3.1.6.1 Implementing Calibration using the Wizard](#).

Follow steps 1 to 6 described below in order to calibrate the origin.

#### 1. Basic Pose Confirmation

For details, refer to [3.1.4 Preparation](#).

#### 2. Part Replacement

Replace parts as dictated by this manual.

\* Be careful not to injure yourself or damage parts during part replacement.

#### 3. Encoder Initialization

- (3)-1 Turn ON the Controller when all joints are in the motion range.
- (3)-2 Manually move the joint that needs origin alignment to its approximate 0 pulse position.

0 pulse position of Joint #1: position aligned with X-axis in Robot coordinate system

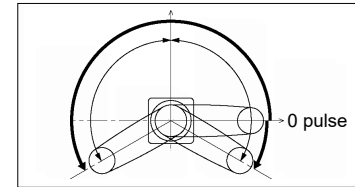

0 pulse position of Joint #2: position where Arm1 and Arm2 are in a straight line (Regardless of the Joint #1 direction.)

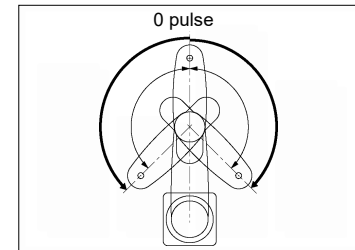

0 pulse position of Joint #3: upper limit position in motion range

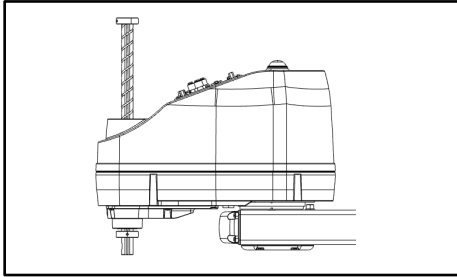

0 pulse position of Joint #4:  
position where the D-Cut on the shaft faces toward the tip of Arm2

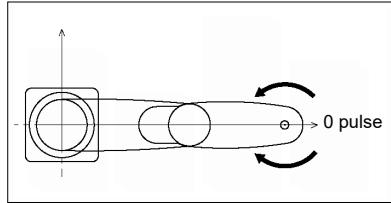

**NOTE** For details on the 0-pulse position, refer to [3.1.5 0-Pulse Position of Each Joint.](#)

- (3)-3 Connect EPSON RC+ to the Controller.  
Select the robot to be calibrated. Enter and execute the following command in [Command Window].  
(This example uses “robot 1”.)  
    > robot 1
- (3)-4 Execute the absolute encoder initialization command.  
Enter and execute one of the following commands in [Command Window] according to the joint being calibrated.  
    Joint #1: >EncReset 1  
    Joint #2: >EncReset 2  
    Joint #3: >EncReset 3  
    Joint #4: >EncReset 3, 4
- (3)-5 Reboot the Controller.  
Select EPSON RC+ menu- [Tools] - [Controller] and click the <Reset Controller> button.

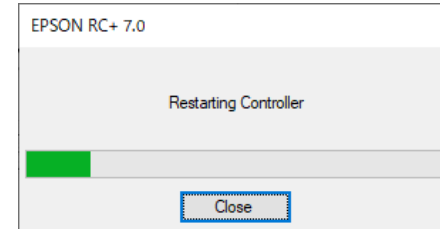

This window will disappear when the Controller starts up.

#### 4. Rough Calibration

- (4)-1 Execute the following command from the menu - [Tools] - [Command Window].  
 >calpls 0,0,0,0  
 \* Manipulator does not move.
- (4)-2 Execute one of the following commands according to the joint you want to calibrate from the menu - [Tools] - [Command Window].  
 Joint #1: >Calib 1  
 Joint #2: >Calib 2  
 Joint #3: >Calib 3  
 Joint #4: >Calib 3, 4

- NOTE**
- Warning 590 (Detect the different of the calibration settings in the controller and Safety Board) occurs when the Calib command are executed.
  - Warning 590 is cleared by updating the Hofs value in the safety board.

#### 5. Calibration (Accurate Positioning)

- (5)-1 Reboot the Controller.  
 Select EPSON RC+ menu - [Tools] - [Controller] and click the <Reset Controller> button.
- (5)-2 Click [Control Panel] - <Free All> button to free all joints. Now, you can move arms by hands.
- (5)-3 Move the Manipulator by hand to a rough position/posture of the calibration point data.
- (5)-4 Create the data from the calibration point data.  
 Enter and execute the following command in [Command Window].  
 (In this example, **P1** is used as the calibration point data.)  
 > Calpls Ppls(**P1**,1), Ppls(**P1**,2), Ppls(**P1**,3), Ppls(**P1**,4)
- (5)-5 Move the joint to the specified point using a motion command.  
 For example, when the specified point data is “P1”, execute “Jump P1:Z(0)” from [Jog & Teach].  
 \* The joint NOT being calibrated moves to the original position.
- (5)-6 Accurately align the joint\* being calibrated to the specified point using jog commands.  
 \* You must move Joint #3 and #4 to the position when calibrating Joint #4.  
 Select the jog mode [Joint] from [Jog & Teach] to execute the jog motion.

- (5)-7 Execute the calibration.  
Enter and execute one of the following commands in [Command Window] according to the joint being calibrated.

Joint #1: >Calib 1  
 Joint #2: >Calib 2  
 Joint #3: >Calib 3  
 Joint #4: >Calib 3, 4

## 6. Accurate Calibration of Joint #2

Perform accurate calibration for Joint #2 with reference to [3.1.6.2 Accurate Calibration of Joint #2](#).

## 7. Send Hofs to Safety board

On RC700E, send the Hofs value to the safety board.  
 \* On RC700D, go on to the step (17).

- (7)-1 In EPSON RC+, select [Setup] - [System Configuration], and then under [Controller] - [Safety Functions], click [Safety Function Manager].

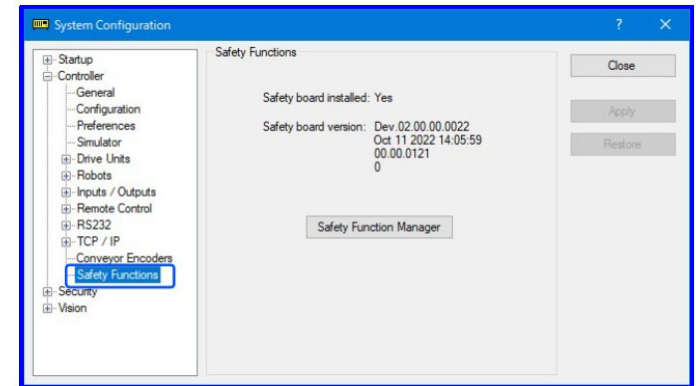

- (7)-2 Confirm the warning message and click the <OK> button.

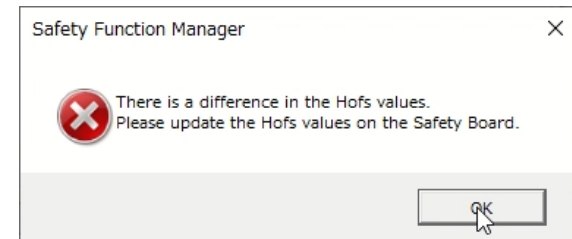

(7)-3 Click <Send HofS to the Safety Board> button.

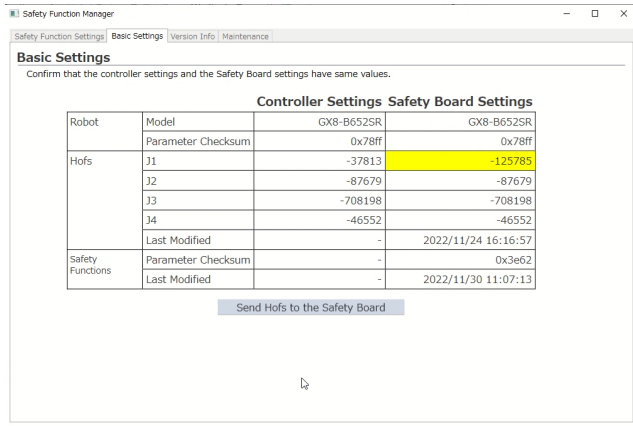

(7)-4 Confirm the warning message and click the <OK> button.

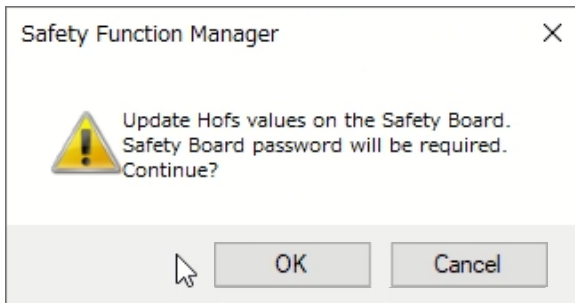

(7)-5 Enter the password and click <Confirm> button.

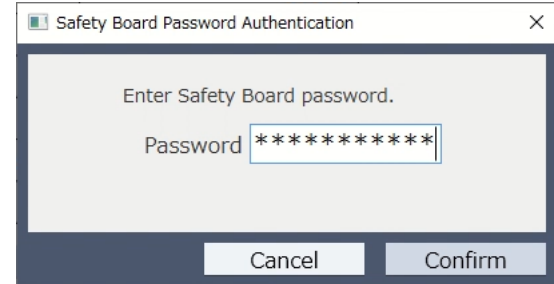

(7)-6 Confirm the warning message and click the <OK> button.

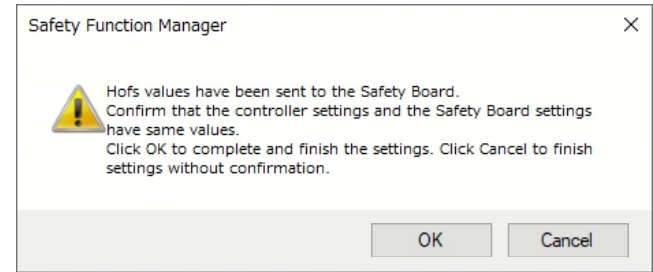

(7)-7 Confirm the message and click the <OK> button.

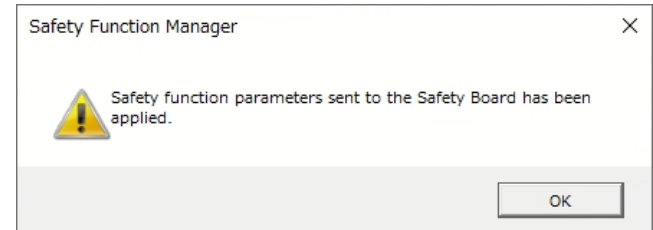

(7)-8 Confirm the message and click the <OK> button.

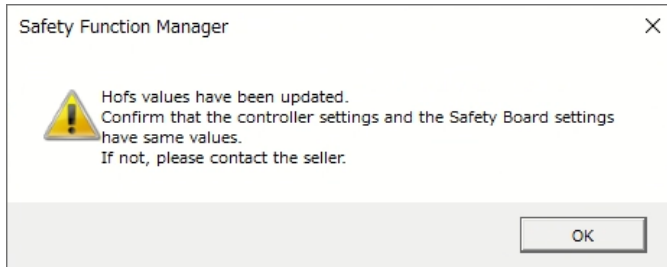

(7)-9 The Controller restarts.

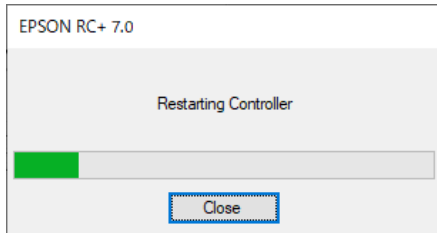

## 8. Accuracy Testing

Move the Manipulator to another point to confirm that it moves to the same position. If it does not move to the same position, re-calibrate using another point. You must set the point again if reproducibility cannot be assured through calibration.

### **3.1.7 Verification**

RC700E is required to verifying the safety function after completing calibration.

For details on the verification procedure, refer to “RC700E Service Manual 3.4 Verifying Safety board operation”.



## 3.2 Adjusting the Timing Belt Tension

The Manipulator uses two types of Timing Belts.

When removing or replacing parts related to the belt, be sure to adjust the tension of the Timing Belt.

### Items to be prepared

- Sonic Belt Tension Meter  
Recommended: U-508 (Gates Unitta)
- Belt Tensioner (For Z belt)

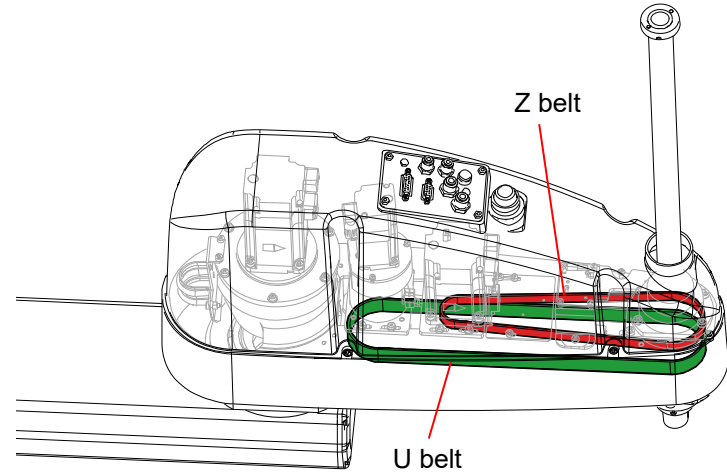

### 3.2.1 Belt Tension Values

#### Tension Meter setting values

	Z	U
MASS (g/m)	3	5.25
WIDTH (mm/R)	12	20
SPAN (mm)	219	298

#### Tension standard values

	Z	U
Belt tension (N)	29.5 to 118.0	49 to 196

### 3.2.2 Adjustment Method

 <b>CAUTION</b>	<p><b>Before adjustment</b></p> <ul style="list-style-type: none"> <li>■ Make sure that the belt is set to be level with respect to the pulley without it being placed on the flange.</li> <li>■ Temporarily tighten the parts used to adjust the belt tension. After adjusting the tension, tighten the bolts with the correct tightening torque.</li> <li>■ Make sure that the bolts securing the jigs are tightened with the correct tightening torque.</li> </ul>	<p><b>During adjustment</b></p> <ul style="list-style-type: none"> <li>■ Take care not to apply excessive tension to the belt.</li> <li>■ Measure the tension near the center of the belt.</li> </ul>
---	---	---

#### Z belt installation

(1) Install Belt Tensioner.

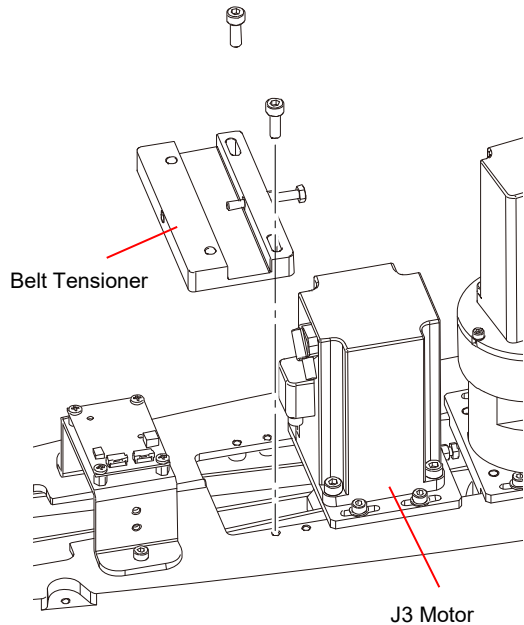

(2) Tighten the bolt in the direction of the arrow, and apply tension to the belt.

For details on the set values, refer to [3.2.1 Belt Tension Values](#).

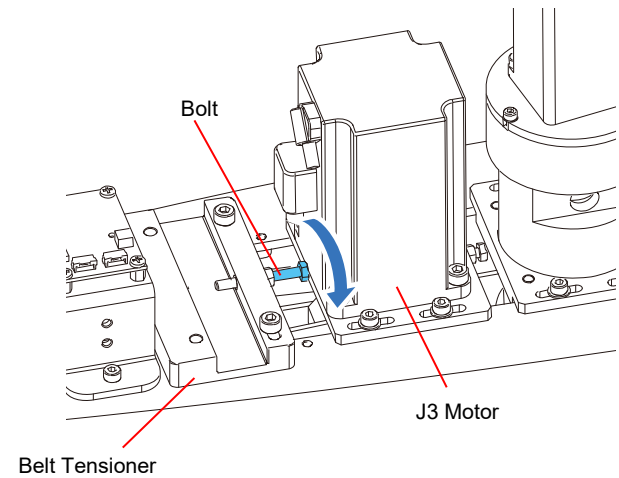

- (3) Measure the tension using a Tension Meter.

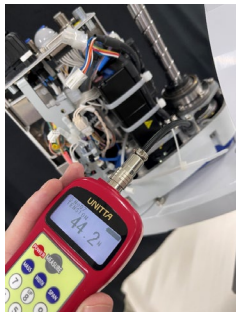

- (4) Tighten the bolts securing the Motor Plate with the correct tightening torque.
- (5) After tightening the bolts securing the Motor Plate, measure the tension once again for confirmation.
- (6) Remove the jig.

## U belt installation

- (1) Tighten the bolt in the direction of the arrow, and apply tension to the belt.  
For details on the set values, refer to [3.2.1 Belt Tension Values](#).

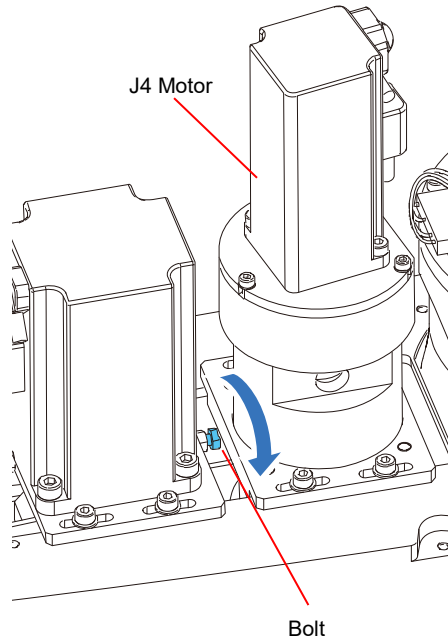

- (2) Measure the tension using a Tension Meter.



- (3) Tighten the bolts securing the Motor Plate with the correct tightening torque.
- (4) After tightening the bolts securing the Motor Plate, measure the tension once again for confirmation.

CHAPTER

4

## Block Diagram/Wiring Diagram

### 4.1 Block Diagram

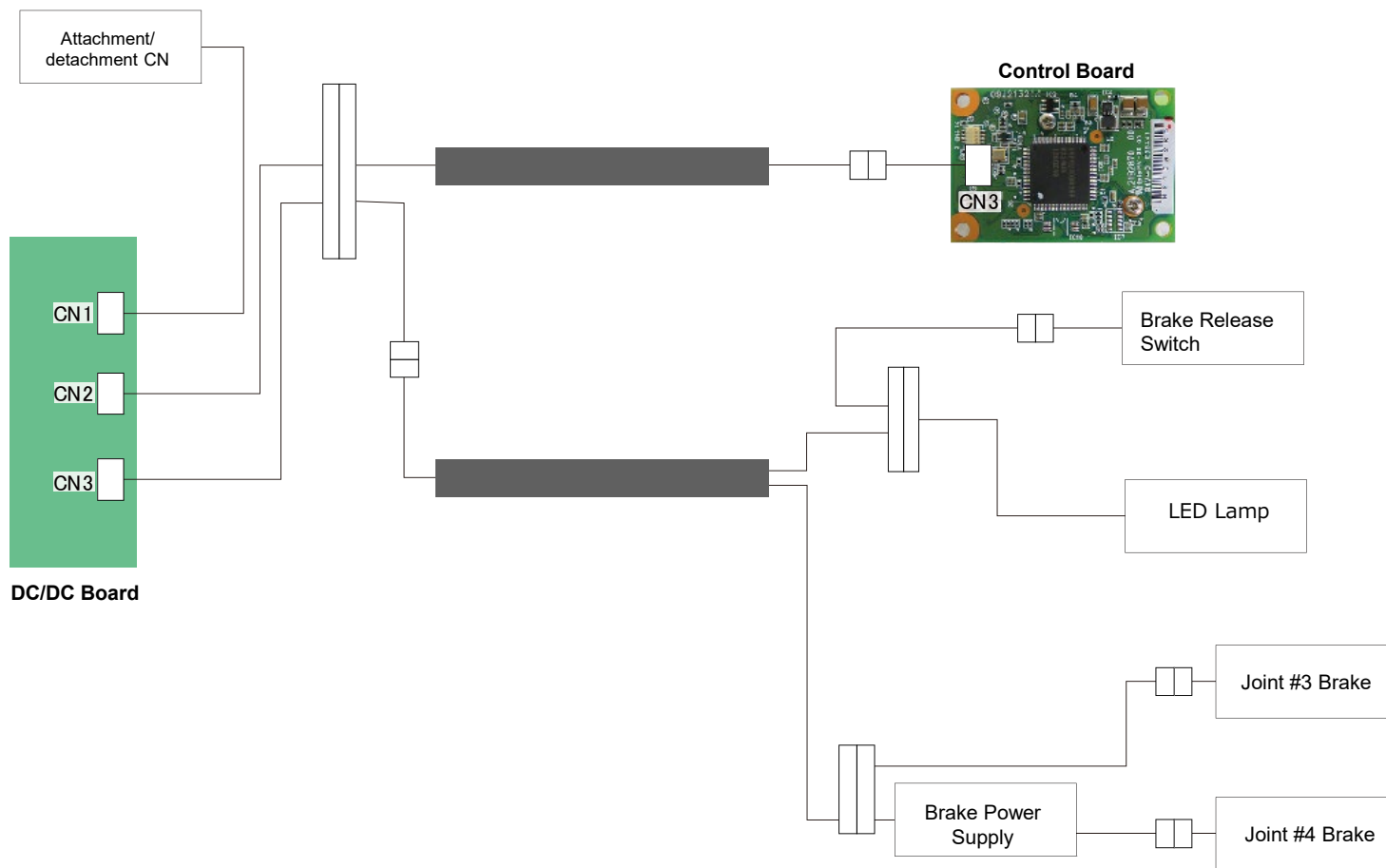

## 4.2 Wiring Diagram

### 4.2.1 Ground Wire

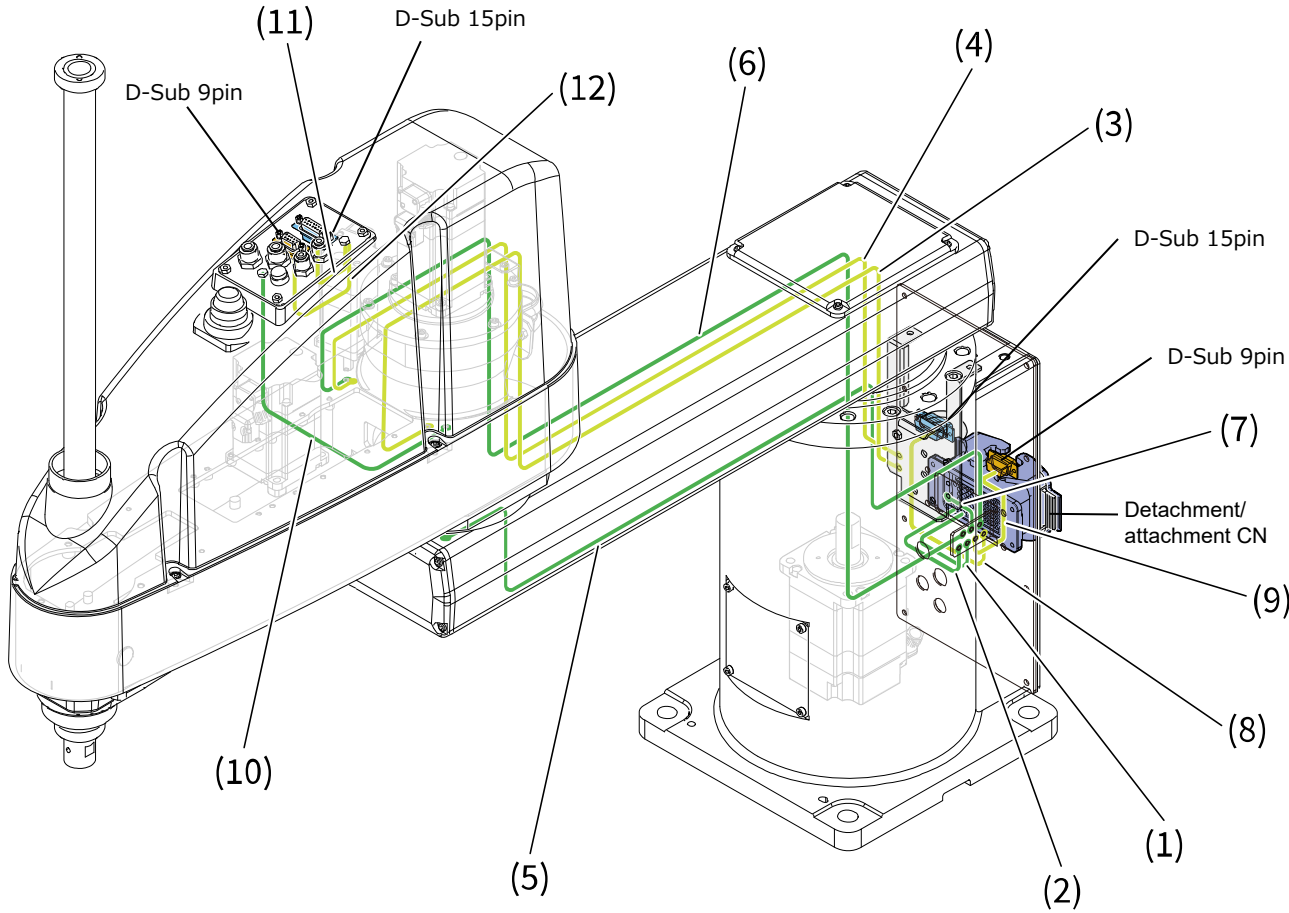

No.	Connection
(1)	PE1 - Detachment/attachment CN
(2)	PE2 - Detachment/attachment CN
(3)	FB1 - FB6
(4)	FB2 - FB7
(5)	PE8 - PE9
(6)	PE4 - PE6
(7)	PE3 - PE5
(8)	FB4 - CN521
(9)	FB5 - CN511
(10)	PE7 - PE10
(11)	FB9 - CN521
(12)	FB10 - CN511



### 4.2.2 Motor Cable

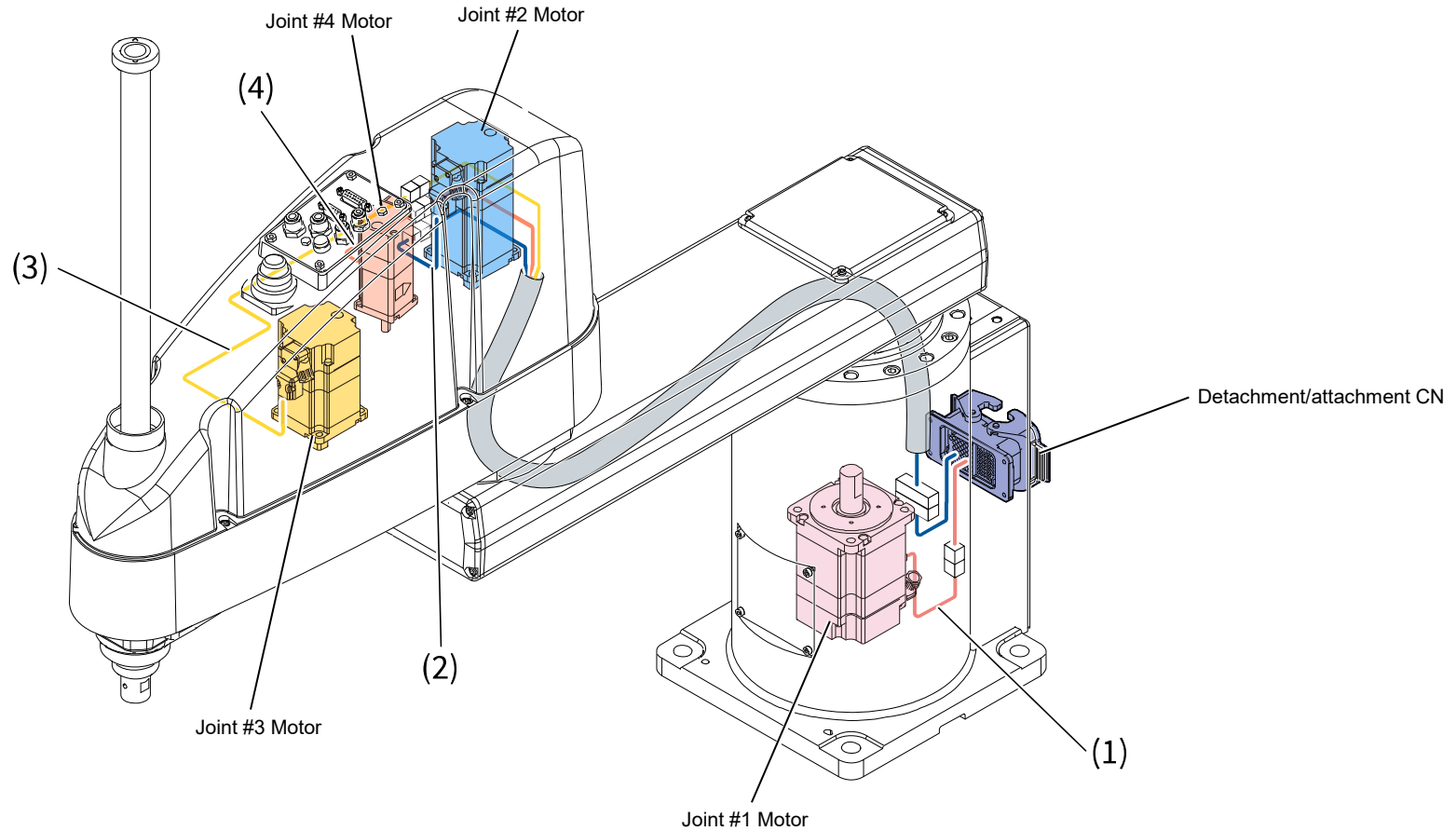

No.	Connection
— (1)	Joint #1 Motor - CN111 - Detachment/attachment CN
— (2)	Joint #2 Motor - CN121
— (3)	Joint #3 Motor - CN131 - CN201 - Detachment/attachment CN
— (4)	Joint #4 Motor - CN141

### 4.2.3 Encoder

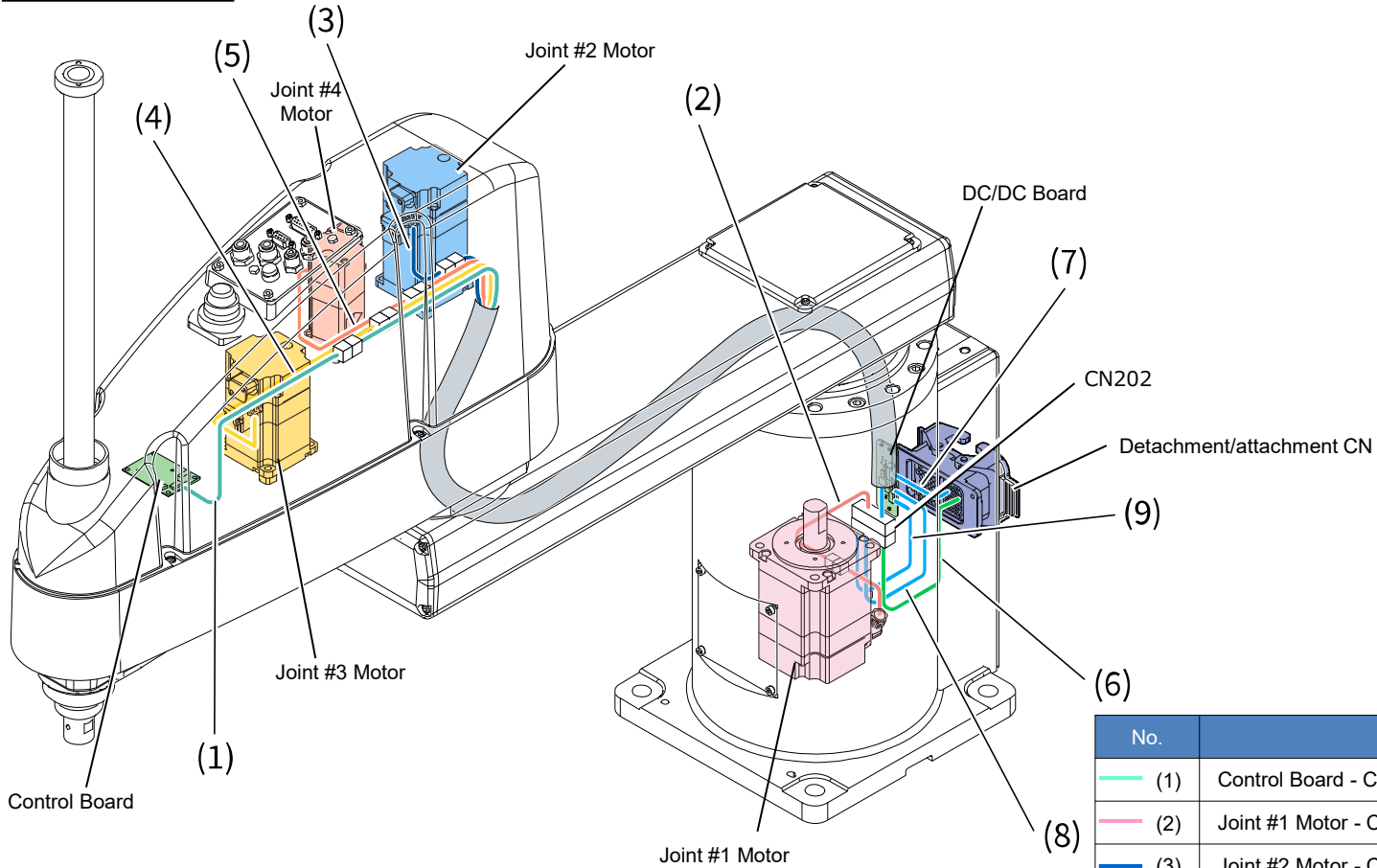

No.	Connection	
(1)	Control Board - CN3G0	
(2)	Joint #1 Motor - CN311	
(3)	Joint #2 Motor - CN321	- CN202
(4)	Joint #3 Motor - CN331	
(5)	Joint #4 Motor - CN341	
(6)	CN202	- Detachment/attachment CN (CN200)
(7)	DC/DC Board (CN1)	
(8)	CN202	- DC/DC Board (CN3)
(9)		- DC/DC Board (CN2)

4.2.4 Brake Wire, LED Wire

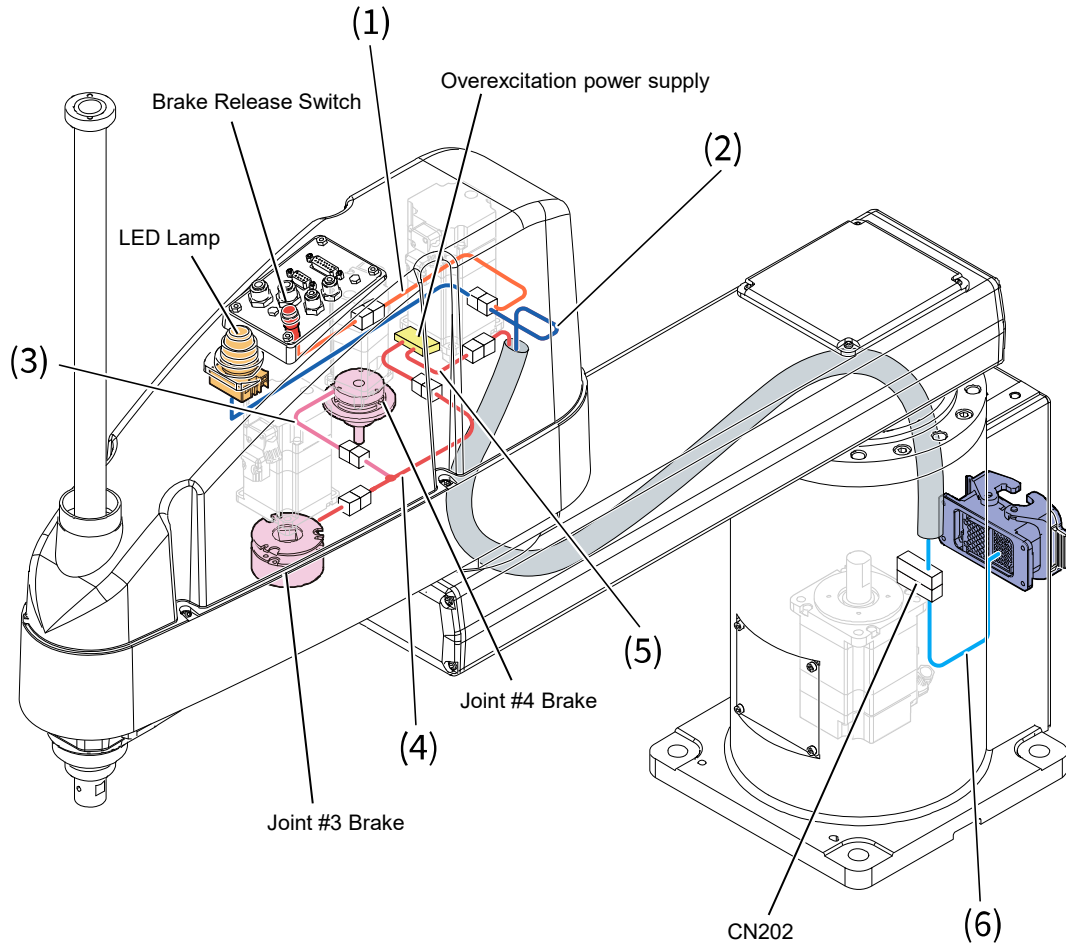

No.	Connection
(1)	Brake Release Switch - CN300 - CN302
(2)	LED - CN302
(3)	Joint #4 Brake - CN440 - Divergence - CN400 - Brake power supply
(4)	Joint #3 Brake - CN430 - Divergence - CN400 - Brake power supply
(5)	Brake power supply - CN401 - CN302
(6)	CN302 - CN301 - CN202

### 4.2.5 User Plate

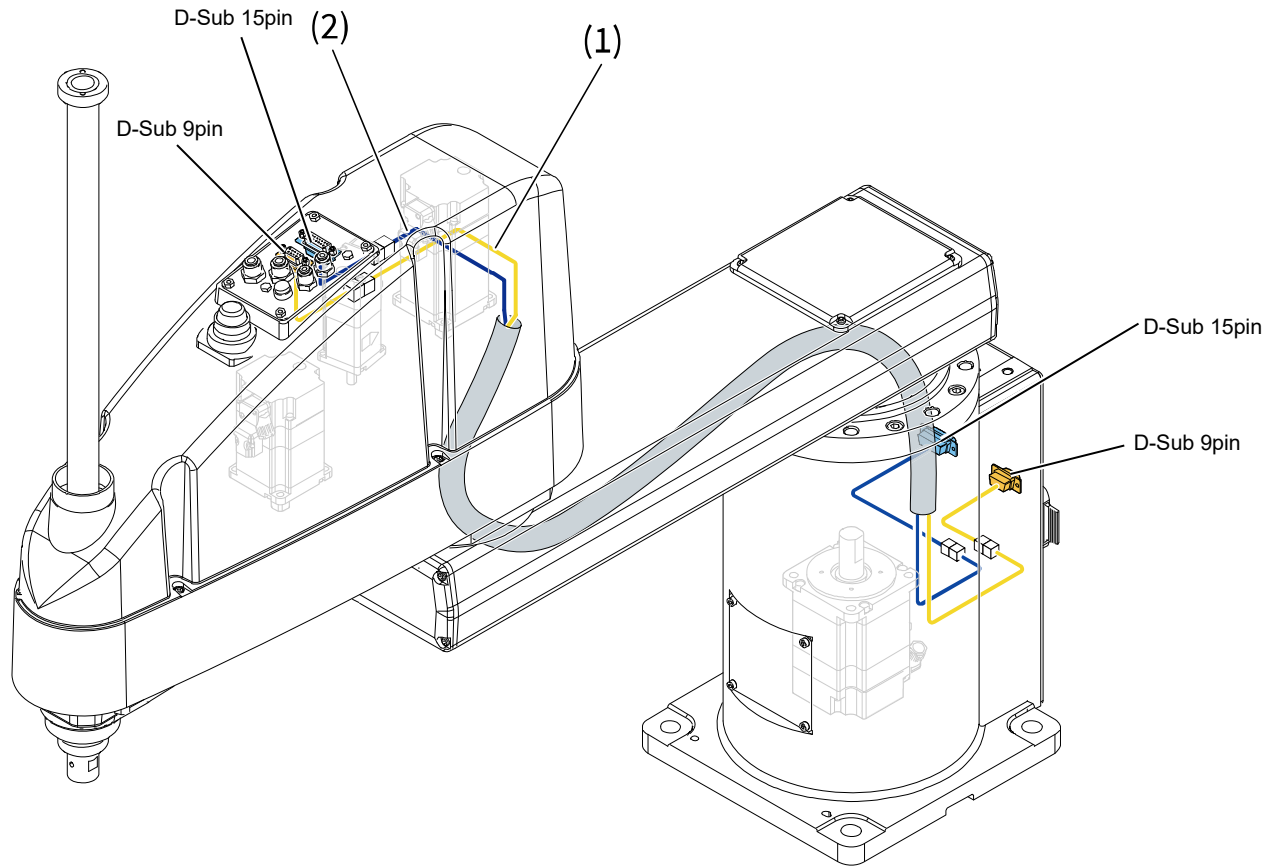

No.	Connection
— (1)	D-Sub 9pin - CN511 - CN511 - D-Sub 9pin
— (2)	D-Sub 15pin - CN521 - CN521 - D-Sub 15pin

CHAPTER

5

## Exploded View/Maintenance Parts List

### 5.1 Exploded View

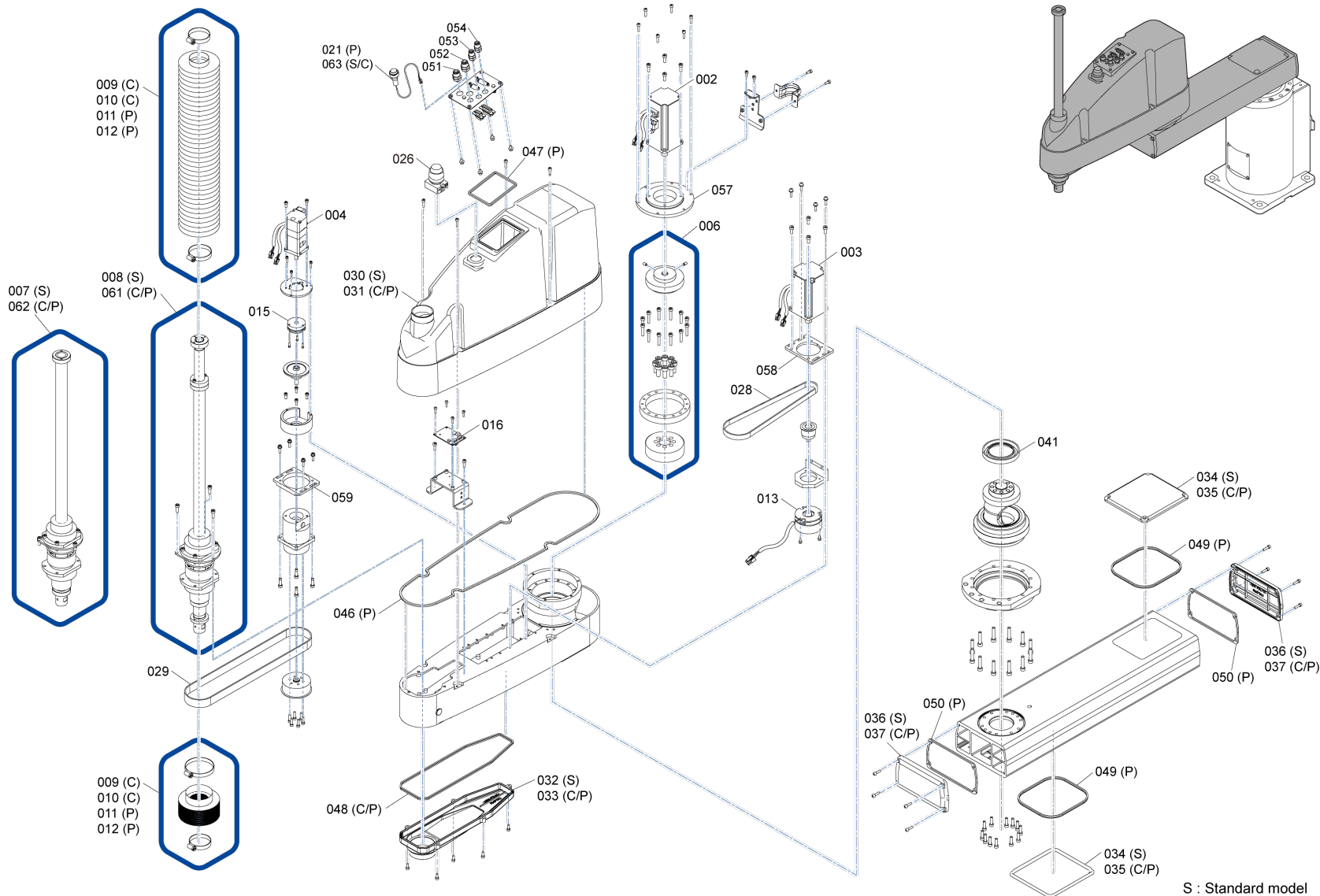

GX20-B No.1

S : Standard model  
 C : Cleanroom model  
 P : Protected model

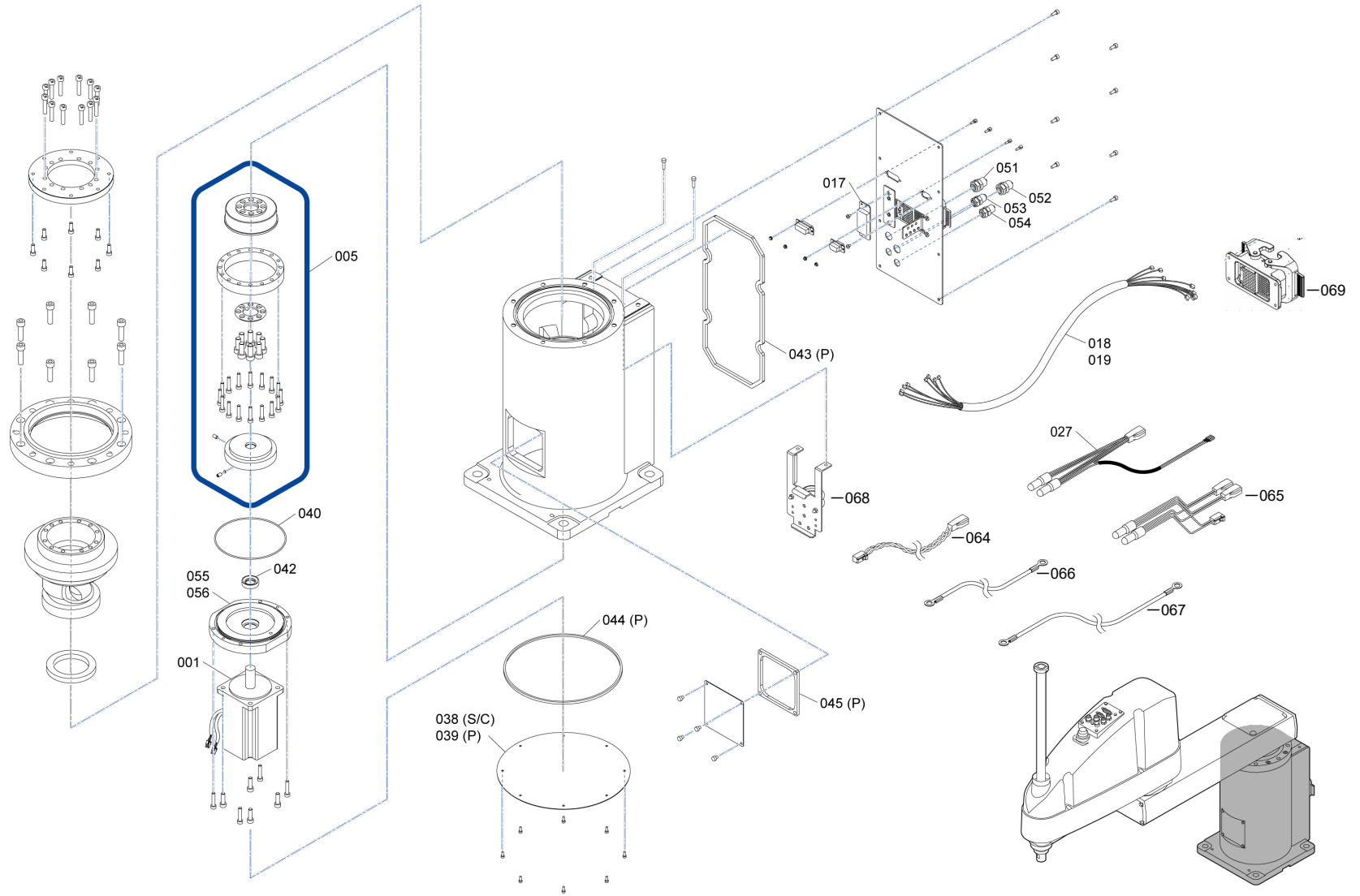

GX20-B No.2

S : Standard model  
 C : Cleanroom model  
 P : Protected model



## 5.2 Maintenance Parts List

Ref. No.	Parts Name	Parts Code	Note	Overhaul
001	AC Servo Motor	2230547	Joint #1	✓
002	AC Servo Motor	2230548	Joint #2	✓
003	AC Servo Motor	2230549	Joint #3	✓
004	AC Servo Motor	2230550	Joint #4	✓
005	Reduction Gear Unit	1922288	Joint #1	✓
006	Reduction Gear Unit	1922354	Joint #2	✓
007	Ball Screw Spline	1922298	Standard model, 180 sets	✓
008	Ball Screw Spline	1922299	Standard model, 420 sets	✓
009	Bellows	1493870	Cleanroom model, 150 sets	
010	Bellows	1493844	Cleanroom model, 390 sets	
011	Bellows	1924658	Protected model, 150 sets	
012	Bellows	1924653	Protected model, 390 sets	
013	Electromagnetic Brake	1922335	Joint #3	✓
015	Electromagnetic Brake	2230563	Joint #4	✓
016	Control Board	2198655		
017	SUB-B Board	2224571		
018	Cable Unit	2224466	850 mm arm	
019	Cable Unit	2224467	1000 mm arm	
021	Brake Release Switch	2232323	Protected model	
026	LED Lamp	2230562		
027	LED Cable	2225144		
028	Timing Belt	1922356	Joint #3 (z) width: 12 mm	✓
029	Timing Belt	1922357	Joint #4 (u) width: 20 mm	✓

Ref. No.	Parts Name	Parts Code	Note	Overhaul
030	Arm2 Cover	1922348	Standard model	
031	Arm2 Cover	1922349	Cleanroom model	
		1930573	Protected model	
032	Under Cover	1901030	Standard model	
033	Under Cover	1493788	Cleanroom model	
		1930574	Protected model	
034	Cap Cover	1488204	Standard model	
035	Cap Cover	1493785	Cleanroom model	
036	Side Cover	1922350	Standard model、Floor Standing Joint #2	
037	Side Cover	1922352	Cleanroom model、Floor Standing Joint #2	
		1930575	Protected model、Floor Standing Joint #2	
038	Base Bottom Cover	1493102	Standard/Cleanroom model	
040	O-ring	1489339	Joint #1 for motor plate	
041	Oil Seal	1489337	Joint #2 for motor flange	
042	Oil Seal	1866758	Joint #1 for motor plate	
043	Rubber Gasket	1493852	For base rear Cover	
044	Rubber Gasket	1495343	For base bottom Cover	
045	Rubber Gasket	1485972	For Blind Cover	
046	Rubber Gasket	1493850	For Arm2 Cover	
047	Rubber Gasket	1485976	For User Plate	
048	Rubber Gasket	1493789	For Under Cover	
049	Rubber Gasket	1495344	For Cap Cover	
050	Rubber Gasket	1493851	For Side Cover	
051	Coupling	1636148	For 6 dia. tube (White)	
052	Coupling	1636149	For 6 dia. tube (Blue)	
053	Coupling	1636146	For 4 dia. tube (White)	
054	Coupling	1636147	For 4 dia. tube (Blue)	

Ref. No.	Parts Name	Parts Code	Note	Overhaul
055	Motor Plate	1900999	Joint #1 Table Top Mounting	
056	Motor Plate	1901002	Joint #1 Wall Mounting / Ceiling Mounting	
057	Motor Flange	1901021	Joint #2	
058	Motor Plate	1493097	Joint #3	
059	Motor Plate	1493096	Joint #4	
061	Ball Screw Spline	1922300	Cleanroom, 150 sets	✓
		1930565	Protected model, 150 sets	✓
062	Ball Screw Spline	1922301	Cleanroom model, 390 sets	✓
		1930566	Protected model, 390 sets	✓
063	Brake Release Switch	2230560	Standard/Cleanroom model	
-	Gap Adjustment Jig	1921770	For Joint #2 waveform generator placement. can be used	
-	Belt Tensioner	1921772	Joint #3 only	
-	Planetary Gear	1922355	Joint #4	
064	Harness	2212440	For Control Board	
065	Harness	2225145	Brake Branch	
066	Harness	2212441	Ground for BASE	
-	Harness	2219118	Ground for bottom Connector Unit	
067	Harness	2213489	Ground for ARM2	
-	Side cover	1922351	Standard model、 Wall Mounting / Ceiling Mounting、 Joint #2	
-	Side cover	1488205	Standard model、 Joint #1	
-	Side cover	1922353	Cleanroom model、 Wall Mounting / Ceiling Mounting、 Joint #2	
-	Side cover	1493786	Cleanroom model、 Joint #1	
068	Saddle	1480868	For cable	
069	Harness · Connector	2212432	M/C Cable Connector (Robot Side)	